

YAESU FP-757GX SWITCHING POWER SUPPLY

The FP-757GX is a solid state switching supply designed to match the FT-757GX All Mode HF Transceiver. The extremely small size and light weight are the obvious advantages of the latest switching supply technology, which eliminates the need for a bulky power transformer. Gone too is the heat caused by power losses in the transformer, resulting in extremely high efficiency and tight regulation over wide ranges of AC input voltage and DC output current demands.

SPECIFICATIONS

Input Voltage:	85 to 132 V or 170 to 264 VAC (selectable)
Output Voltage:	13.5 VDC at rated load (approx. 15 V at 1 A)
Load Rating:	1 A to 20 A (50% duty cycle at 20 A less than 30 seconds)
Ripple:	600 mV p-p at 20 A
Operating Temperature Range:	0°C to 40°C
Case Size (WHD):	238 x 39 x 238 mm
Weight:	approx. 2 kg (4.4 lb)

INSTALLATION

Although the high efficiency of the FP-757GX allows it to run cool even at high current, care must be taken to avoid overheating in conditions of very high humidity and/or ambient air temperature. Make sure that adequate space is provided for the free flow of air around the sides of the FP-757GX at all times.

INTERCONNECTIONS

Before connecting the FP-757GX, check that the voltage range on the label on the rear panel near the AC power jack includes your local AC line voltage. If not, perform the AC Voltage Change procedure below before connecting power. Connect the DC 13.5 V cable from the FP-757GX to the DC 13.5 V jack on the rear panel of the FT-757GX. Check to make sure that all POWER switches are OFF, and then connect the AC cord to the wall outlet.

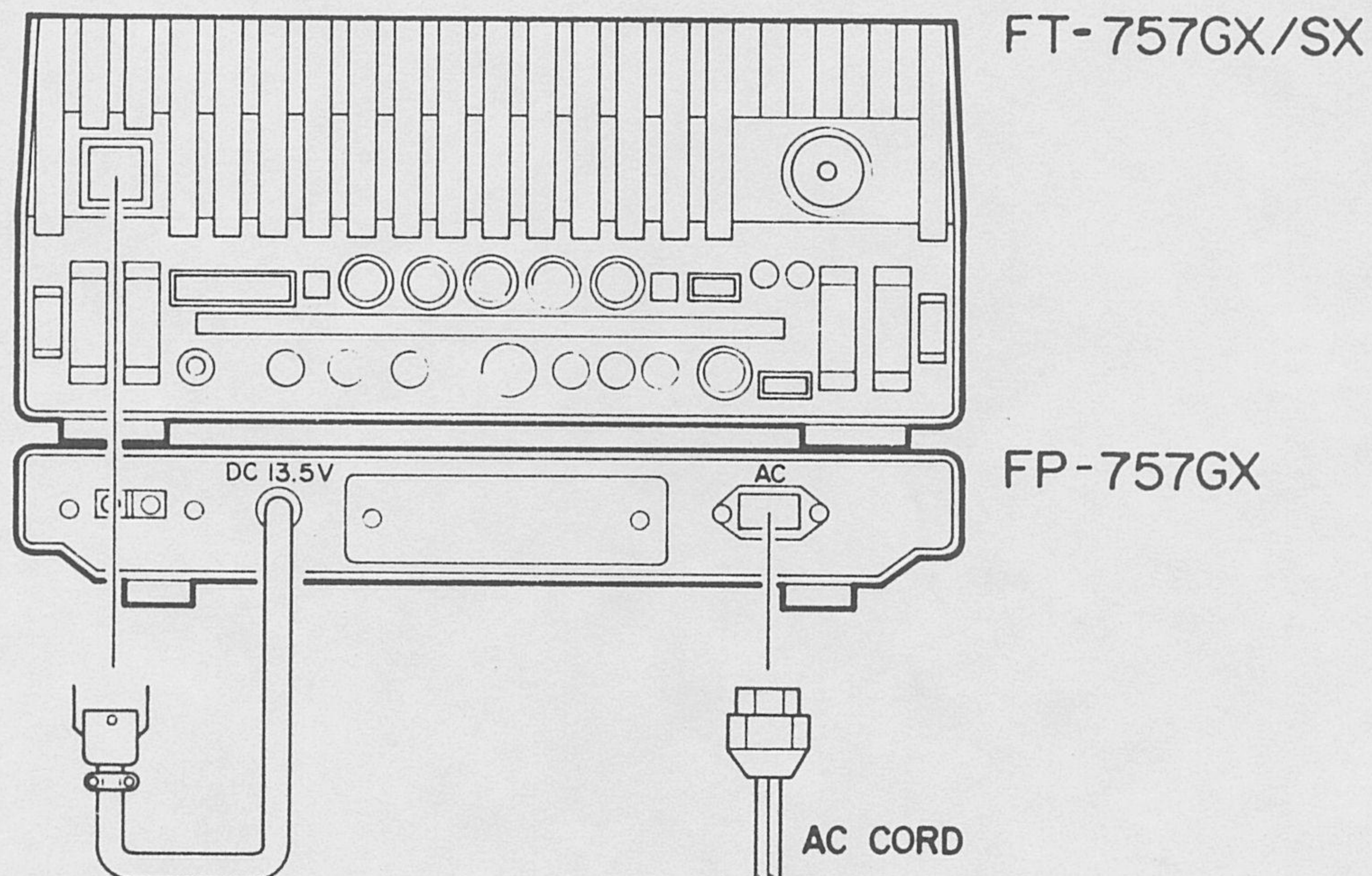

OPERATION

Always switch the power supply on before the transceiver, and switch the transceiver off before the power supply. This will avoid possible damage to the transceiver due to supply transients.

While the FP-757GX is capable of providing 20 A with a 50% duty cycle, full power drain periods must be limited to 30 seconds. For 100% continuous duty operation, current drain must be limited to below 10 A.

Auxiliary DC terminals are provided on the rear of the FP-757GX for powering other equipment that requires 13.5 VDC. Current drain from these terminals is limited to 10 A, but in no case should the total current drain from the supply exceed 20 A.

The automatic protection circuit in the FP-757GX will shut off output from the supply if current drain exceeds approximately 25 A. If this occurs, switch off the supply POWER switch and all connected equipment, and investigate the cause (such as a short circuit in the DC supply line or connectors). Once the problem is corrected, and after at least 10 seconds, switch the FP-757GX back on, followed by the FT-757GX and other equipment. If the power supply fails to come on, a short may still be present at the output, or the automatic protection circuit may have failed, in which case the AC line fuse inside the FP-757GX will have blown. To replace the fuse, remove the two screws and subpanel on the rear of the supply, and use a 5 A fuse ONLY, for replacement.

AC VOLTAGE CHANGE

If the AC voltage range marked on the rear panel of the FP-757GX (near the AC jack) does not include your local AC line voltage, remove the two screws and subpanel on the rear of the supply. Locate the jumper plug at the left side of the opening (when viewed from the rear), and notice that this plug jumpers two of the three pins on the mating connector. To change the AC range of the supply, simply remove the jumper plug and reinstall it so that the center pin of the connector is now jumpered to the pin that had no connection previously.

Now replace the subpanel and its two screws, and replace the AC voltage sticker with one that shows the new range.

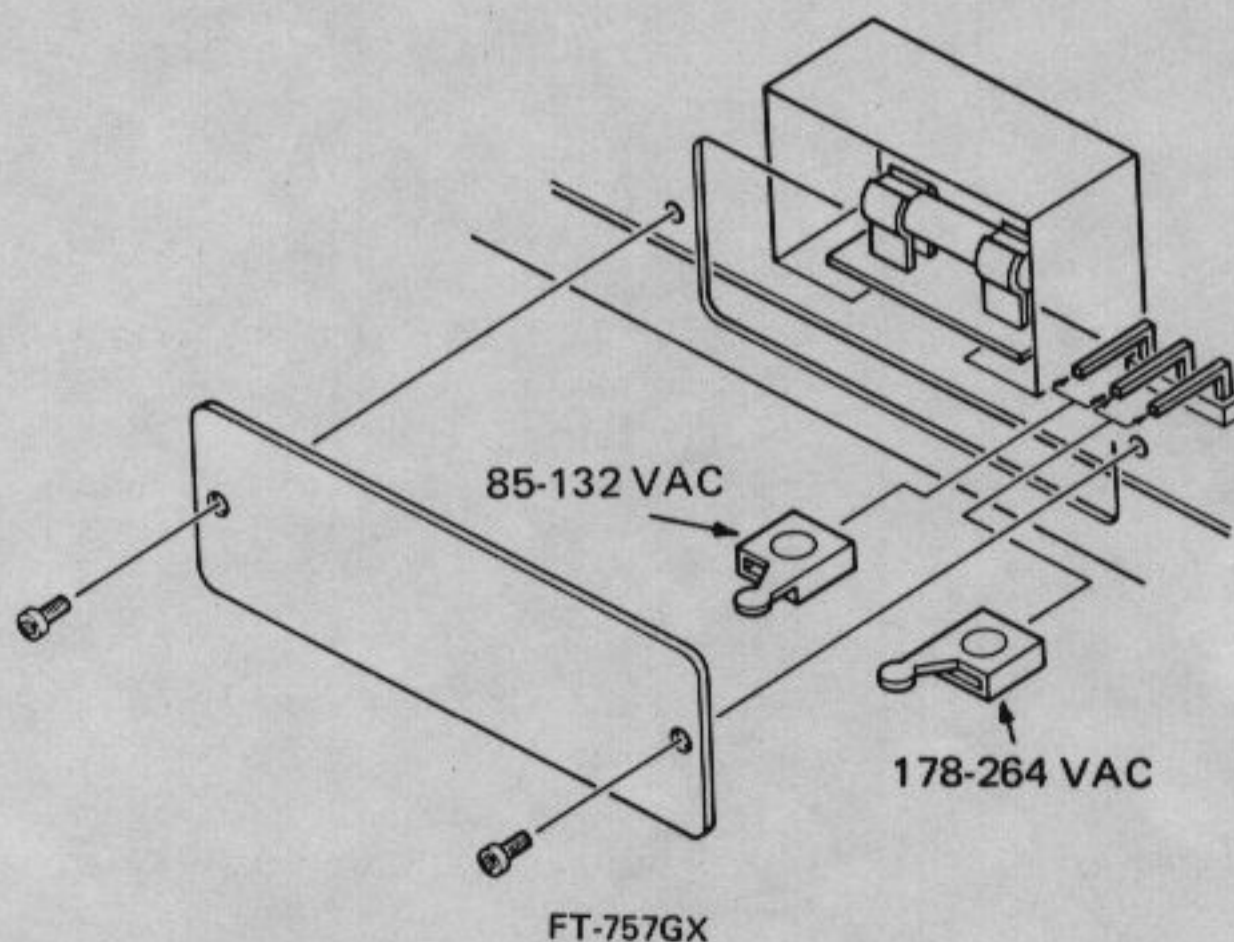

FP-757GX PARTS LIST

MAIN CHASSIS			R01,02		RESISTORS		
Symbol No.	Part No.	Description	R03,04	J20335101	Metallic film	2W	100 Ω
		LED	R05,06	J20335104	" "	"	100 kΩ
LED1	G2090136	TLG-205	R08	J20355102	" "	3W	1 kΩ
			R09,10	J10375010	Metal solid	5W	1 Ω
		LED SOCKET	R11	J30376100	Cement	5W	10 Ω
P3	P1090416	TLS-U01X-A1	R12,18	J20305470	Metallic film	1W	47 Ω
			R13,23,42	J20305101	" "	"	100 Ω
			R14,15	J00245102	Carbon film	¼W	1 kΩ
		CONNECTORS	R16,17	J20355163	Metallic film	3W	16 kΩ
P1	P1090414	5196-02	R19	J20335102	" "	2W	1 kΩ
P2	P1090415	5196-03	R20,27,28	J00245111	Carbon film	¼W	110 Ω
P5	P1090042	QS-P4FK	R21,24,38	J00245121	" "	"	120 Ω
		TERMINALS	R22	J00245103	" "	"	10 kΩ
J4	P0090094	NC-174	R25	J00245202	" "	"	2 kΩ
J5	Q6000083	D-05-2P	R26,35	J00245123	" "	"	12 kΩ
			R29	J00245272	" "	"	2.7 kΩ
		SWITCH	R30,31	J00245154	" "	"	150 kΩ
SW1	N2090030	EST-159R	R32	J00245124	" "	"	120 kΩ
			R33	J00245333	" "	"	33 kΩ
			R34	J00245101	" "	"	100 Ω
			R36	J00245363	" "	"	36 kΩ
		MAIN UNIT	R37	J00245122	" "	"	1.2 kΩ
		Printed Circuit Board	R39	J00245153	" "	"	15 kΩ
		FP1114-051	R40	J00245912	" "	"	9.1 kΩ
			R41	J00245221	" "	"	220 Ω
		TRANSISTORS	R43	J20305102	Metallic film	1W	1 kΩ
Q1,2,7	G3328340A	2SC2834A	R44	J20335479	" "	2W	4.7 Ω
Q3	G3309450	2SC945		J20305681	" "	1W	680 Ω
Q4	G3107330	2SA733					
Q5	G3106840	2SA684					
Q6	G3325940	2SC2594	VR01				
				J51763501	ET-6P		500 ΩJ
		TRIAC					
SCR01	G3090063	AC08DGML					
			C01,02,17,18	-			Not used
		THYRISTOR	C03,04	K52280005	Metalized film	630 WV	0.1 μF
SCR02	G3090064	03P4M	C16,19,20	K52280003	Metalized film	630 WV	0.01 μF
			C05	K13149001	Ceramic	25 WV	0.1 μF
IC01	G1090612	MB3759	C06	K40149005	Electrolytic	25 WV	1000 μF
		DUAL SCHOTTKY DIODES	C07,10,40	K52280004	Metalized film	630 WV	0.001 μF
DB01,02	G2090298	C25P04Q	C08	K40149026	Electrolytic	25 WV	4700 μF
		DUAL SILICON DIODES	C09	K40149008	" "	"	10 μF
DB03	G2090299	CTM26S Cathode Common	C11,12	K40179012	" "	50 WV	4.7 μF
DB04	G2090300	CTM26R Anode Common	C13,14	K52240004	Metalized film	250 WV	1 μF
		DUAL FAST RECOVERY DIODE	C15,23	K40149003	Electrolytic	25 WV	100 μF
DB05	G2090301	CTU26S Cathode Common	C21,22	K12339001	Ceramic disc	2 kV	0.0022 μF
		ZENER DIODE	C24,33,41	K13179012	Ceramic disc	50 WV	0.01 μF
ZD01	G2090302	RD36E	C25,26	K12329002	" "	1.5 kV	0.0047 μF
		FAST RECOVERY DIODES	C27,28	K12339002	" "	2 kV	0.001 μF
D01-10,12-14	G2090303	EU2A	C29,30	K40239001	Electrolytic	200 WV	470 μF
		SILICON DIODE					
D11	G2090304	S5500G					

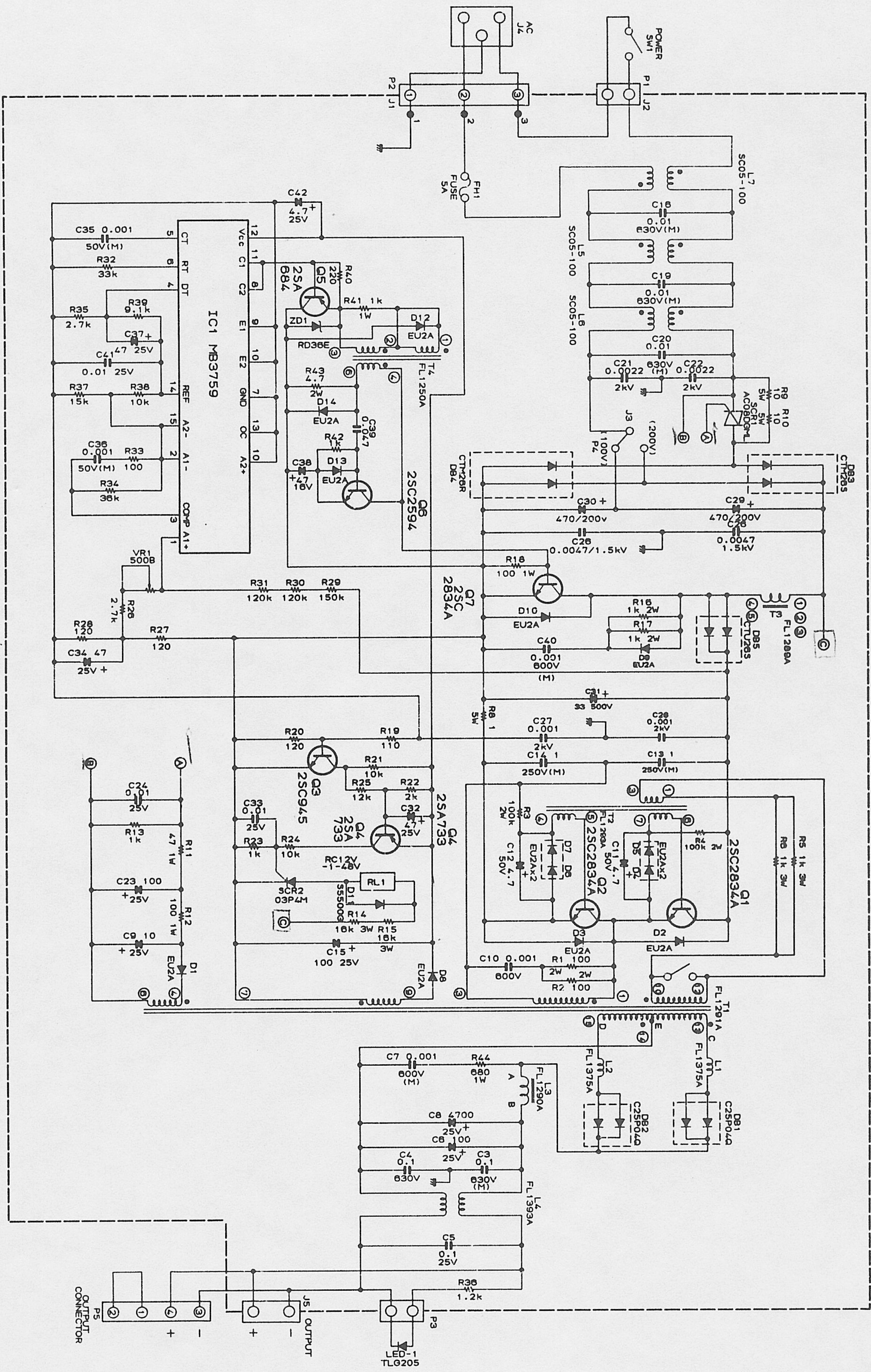

FP-757GX
CIRCUIT DIAGRAM