

TEAC[®]



SERVICE MANUAL

A-9/A-7

Integrated DC Servo Amplifier

1 SPECIFICATIONS

Type Integrated DC Servo Amplifier

Rated Output Power 60 W + 60 W (A-7: 40 W + 40 W), Both channels, 8 ohms

20 Hz – 20 kHz, 0.01%, T.H.D.

Input Sensitivity

PHONO MC 50 μ V/33 ohms

PHONO MM 2.4 mV/50 kohms

TUNER/AUX/TAPE 1.2 200 mV/ 18 kohms

MIC 1.8 mV/50 kohms

Rated Output Voltage/Impedance

TAPE REC 1.2 200 mV/50 kohms

Output Bandwidth –3 dB, 0.1%, 10 Hz – 80 kHz

Frequency Response RIAA 20 Hz – 20 kHz \pm 0.5 dB

TUNER/AUX/TAPE 1.2 15 Hz – 80 kHz \pm 0, –2 dB

MIC 50 Hz – 40 kHz \pm 0, –3 dB

Tone Controls

BASS 100 Hz \pm 10 dB

TREBLE 10 kHz \pm 10 dB

Subsonic Filter 25 Hz, 18 dB/oct

Harmonic Distortion (Rated Output)

PHONO MC to SP 0.05%

PHONO MM to SP 0.025%

TUNER/AUX/TAPE 1.2 to SP 0.01%

Equivalent Input Noise (IHF A Network)

PHONO MC S/N 67 dB

PHONO MM S/N 82 dB

TUNER/AUX/TAPE 1.2 S/N 95 dB

Damping Factor over 30 (20 – 20 kHz)

Muting –20 dB

Power Requirements (Rated Output)

100/120/220/240 V AC 50/60 Hz, 104 W (A-7: 94 W)

(General export models)

120 V AC 60 Hz, 120 W (A-7: 105 W) (U.S.A.)

120 V AC 60 Hz, 2.1 A (A-7: 1.8 A) (Canada)

220 V AC 50 Hz, 290 W (A-7: 240 W) (EUR)

240 V AC 50 Hz, 340 W (A-7: 310 W) (U.K./Aus.)

Dimensions (W x H x D) 410 x 91 x 331 mm (16-1/8" x 3-9/16" x 13-1/16")

Weight 7.5 kg (16-9/16 lbs) (A-7: 6.5 kg (14-5/16 lbs) net)

- Improvements may result in specification or feature changing without notice.

NOTES

1. In this manual, 0 dB is referenced to 1 V.
2. Δ Parts marked with this sign are safety critical components. They must always be replaced with identical components – refer to the appropriate parts list and ensure exact replacements.
3. PC boards shown are viewed from foil side.

2 VOLTAGE CONVERSION

(GENERAL EXPORT MODEL ONLY)

BE SURE TO REMOVE THE POWER CORD FROM THE AC OUTLET BEFORE REMOVING THE METAL COVER AND REPOSITIONING THE VOLTAGE CONVERSION PLUG.

1. Remove the metal housing covering the top and sides of the deck by removing the screws from each side of the metal cover.
2. Locate the voltage selector plug on the left side of the A-9/A-7.
3. Remove the plug by pulling it out, then re-insert it so that the arrow on the plug is aligned with the white line indicating the proper voltage.
4. Replace the cover.

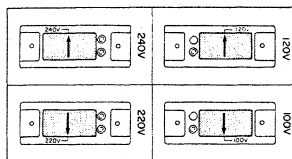

Fig. 2-1

3 PARTS AND ADJUSTMENTS LOCATION

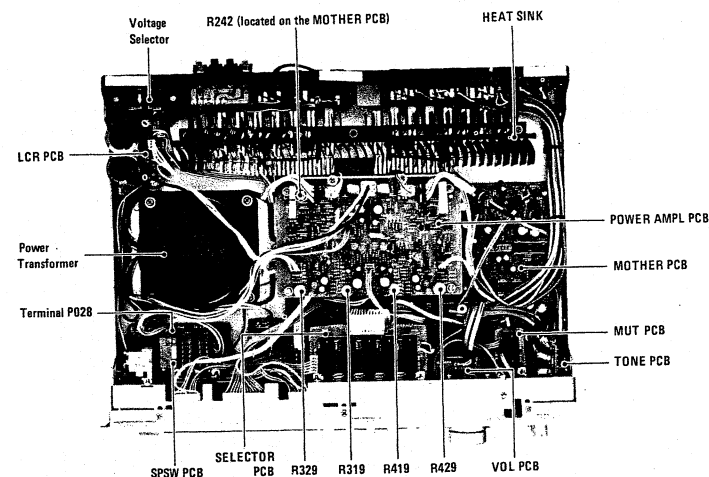

Fig. 3-1

4 ADJUSTMENTS

PRECAUTIONARY NOTES

1. 0 dB is referenced to 1 V.
2. Adjustments should be conducted after a warm-up period of 5 minutes or more.
3. Make sure the A-9/A-7 is properly set for the voltage in your locality.
4. Adjustments and checks are done in the order of L-ch then R-ch. Double REF Nos. indicate L-ch/R-ch (Example: R319/R419).

4-1 INITIAL SETTINGS

Without applying AC power, set the controls as shown below.

Control	Position or setting
SPEAKERS	A
SELECTOR	AUX
VOLUME	Max.
BALANCE	Center
TONE	OUT
LOUDNESS	OUT
MODE	STEREO
MUTING	OUT
Trim pot R242	Center
Trim pots R319/R419	Center
Trim pots R329/R429	Fully counterclockwise

4-2 PRE-ADJUSTMENT CHECK

1. Connect an oscilloscope to pin 1/pin 2 of terminal P028 on the SPSW PC board.
2. Apply AC power at about 1/2 the rated voltage (e.g., 60 V for U.S.A. models; 110 V for EUR models) to the A-9/A-7.
3. Apply a 1 kHz signal at about 100 mV RMS (-20 dB) to both L-ch and R-ch AUX input terminals.
4. Check that a 1 kHz sine wave appears at about 28 V(p-p) for the A-9 (or about 24 V(p-p) for the A-7) on the oscilloscope.

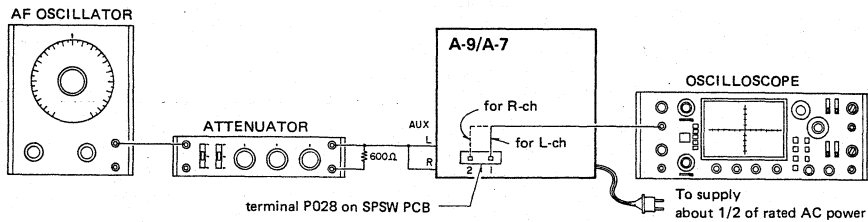

Fig. 4-1 Connection for pre-adjustment check

4-4 POWER METER ADJUSTMENT

1. Apply a 1 kHz, 200 mV (-14.0 dB) signal to both L-ch and R-ch AUX input terminals.
2. Adjust VOLUME control so that the 6th LED from left in L-ch power meter lights up with the full intensity and simultaneously the 7th LED lights up very dimly.
3. Adjust R242 so that R-ch power meter indicates the same level as that of L-ch set in the above step.
4. Check that when varying the VOLUME control from the minimum position to the maximum position, both channels' power meters indicate nearly the same level.

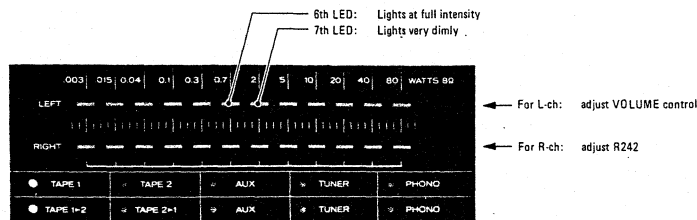

Fig. 4-2 Power meters

4-3 DC BALANCE AND IDLING CURRENT ADJUSTMENTS

DC balance

1. Make the test connections shown in Fig. 4-3 (A).
2. With no signal at both L-ch and R-ch AUX input terminals, after the DC output voltage shows a stable reading on the DC voltmeter, adjust R319/R419 to obtain 0 ± 25 mV at the L-ch and R-ch SPEAKERS A terminals.

Idling current

3. Connect dummy resistors to both L-ch and R-ch SPEAKERS A terminals as shown in Fig. 4-3 (B).
4. Apply a 20-kHz, -30 dB (31.6 mV) signal to both L-ch and R-ch AUX input terminals.
5. Check that output power from SPEAKERS terminal A is about 1 W (+9 dB) per channel.
6. While monitoring the output waveform at point (A) together with its distortion waveform at point (B), gradually turn R329/R429 until the pulse-like distortion in the crossover portion is reduced to the same level as the residual noise products. Be sure that the trim pots remain in the exact position in which the distortion is reduced to the optimum level.

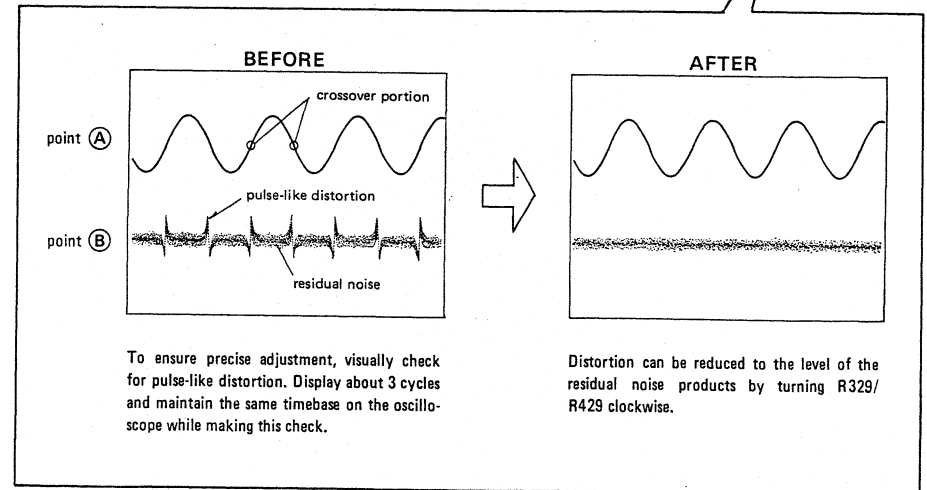
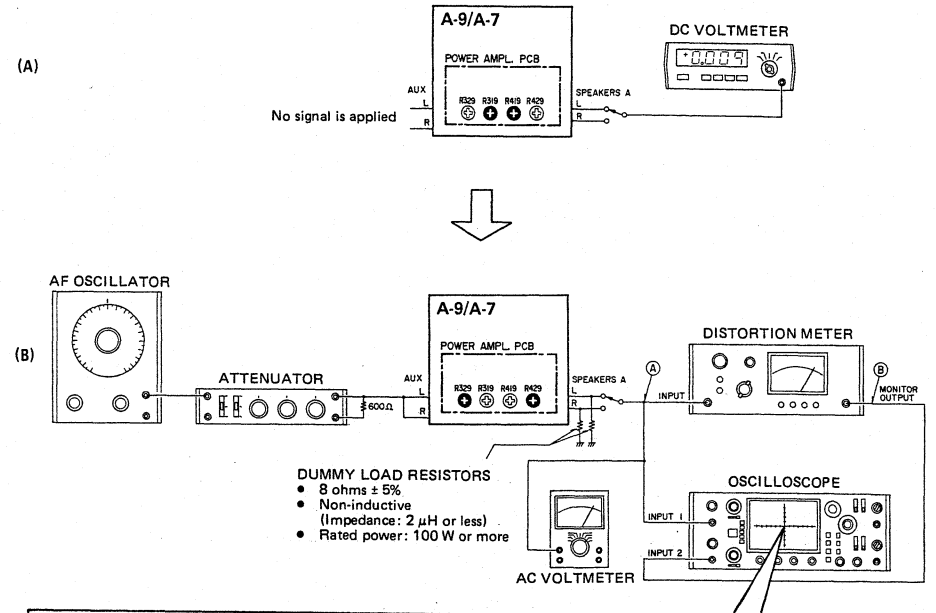

Fig. 4-3 DC balance and idling current adjustment

5 SPECIAL CIRCUIT SKETCH

5-1 DOUBLE INTEGRAL DC SERVO POWER AMPLIFIER

This double integral servo amplifier is illustrated in simplified form in Fig. 5-1. Fig. 5-2 provides an even simpler basic outline of the circuit.

To simplify explanation, the circuit is divided into a power amplifier section and a DC servo amplifier section.

In the power amplifier section, the first stage employs a current mirror load and differential amplifier circuit (Q301, Q302 and Q303), and the final stage adopts a pure complementary Darlington design (Q310, Q311, Q501 and Q503). The first stage, due to the provision of a twin transistor (Q303), results in a DC amplifier with good DC stability.

In the DC servo amplifier section, the DC NFB circuit is separate from the NFB circuit for audio signals (R312 and R305), for maximum DC stability. This servo amplifier also uses a double integral DC servo circuit for DC detection and optimum speaker

damping characteristics.

Audio signals and DC components are integrated by R313 and C311, then are added to the positive input of U308. Next, DC voltage alone is amplified by the integral amplifier (U308, R321 and C307), and the DC voltage at the output point of U308 is integrated by R324 and C305 then added to the negative input of the power amplifier, establishing a DC servo loop. The DC servo amplifier provides time constants which form a highly effective double integral circuit. As shown in Fig. 5-3, this circuit produces a very steep filtering action for ultra-low frequencies, optimizing damping capability and preserving a very wide bandwidth. Since the DC servo amplifier's DC gain is approx. 1000 times, and because DC is amplified then negatively fed back, net DC gain is insignificant, therefore, DC is prevented from being output to the speakers, protecting the speakers and providing less distortion and cleaner sound.

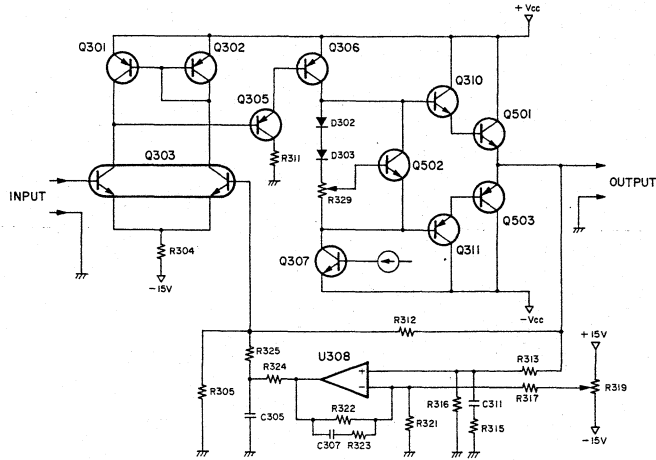

Fig. 5-1 Outline of double integral servo circuit (1)

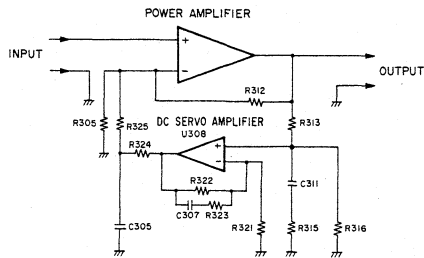

Fig. 5-2 Outline of double integral servo circuit (2)

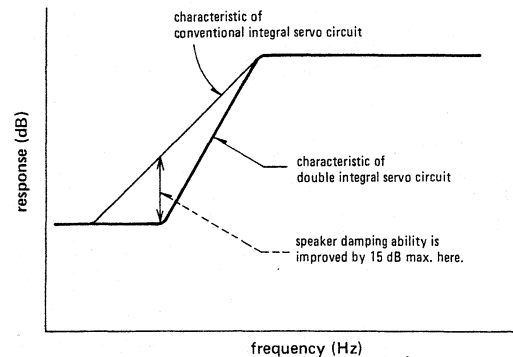

Fig. 5-3 The characteristics of double integral servo circuit

5-2 LED POWER METER DISPLAY

The LED power meter display circuit consists of 12 LED segments for each channel as shown in Fig. 5-4.

Both channel's signals appearing at the speaker output terminals are rectified by U305, then compressed by the $X^{1/4}$ compressor circuits in U305 so that the corresponding output power of the various signal levels can be displayed by the LED power meters. In U305, both channel's signals are compressed into DC levels, then output individually. The DC level of each channel is amplified by U306 (1/2) in each channel, then passed to a switching circuit consisting of Q106 and Q206. Here, left and right channel DC levels are alternately switched by an oscillation frequency generated by a multivibrator consisting of Q709 and Q710, and are then sent to U307. In U307, there are 12 level comparators. Each has its own reference level increasing by approx. 0.25 V in ascending order from comparator #1 to #12. Each comparator goes ON when the DC level is higher than its reference level. The output of each comparator activated is current amplified by a corresponding transistor (one each in

Q711 to Q722), then added as voltage to the point where the anodes of the left and right LEDs corresponding to a specific transistor are connected. The cathodes of these LEDs are alternately grounded by means of a switching circuit consisting of Q105 and Q205. The outputs of the multivibrator (Q709 and Q710) are connected to the circuit consisting of transistors Q105 and Q205 so that the transistor opposite to the channel turned ON in the Q106 and Q206 switching circuit goes ON. That is to say, when the left (right) channel DC signal is received by a comparator, the Q105 and Q205 circuit grounds a corresponding left (right) channel LED cathode. The switching frequency is approx. 1 kHz, determined by the Q709 and Q710 multivibrator. Q723 is connected to the emitters of Q105 and Q205 and is provided so that when the POWER switch on the A-9/A-7 is turned OFF, current passing through the LED(s) is immediately shut off to turn off the LED bar-lamps. R242 semi-fixed resistor adjusts right channel sensitivity so that the sensitivity of both channels is equal.

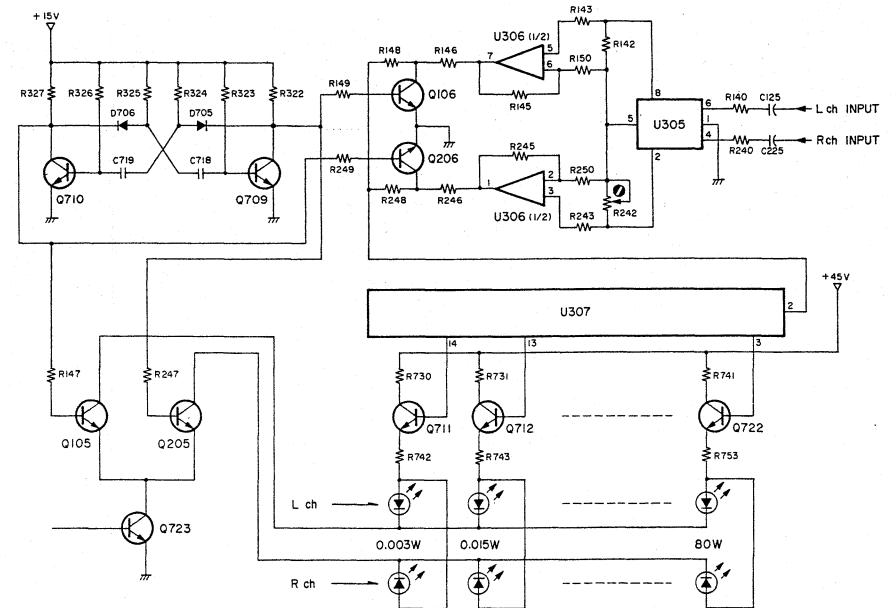
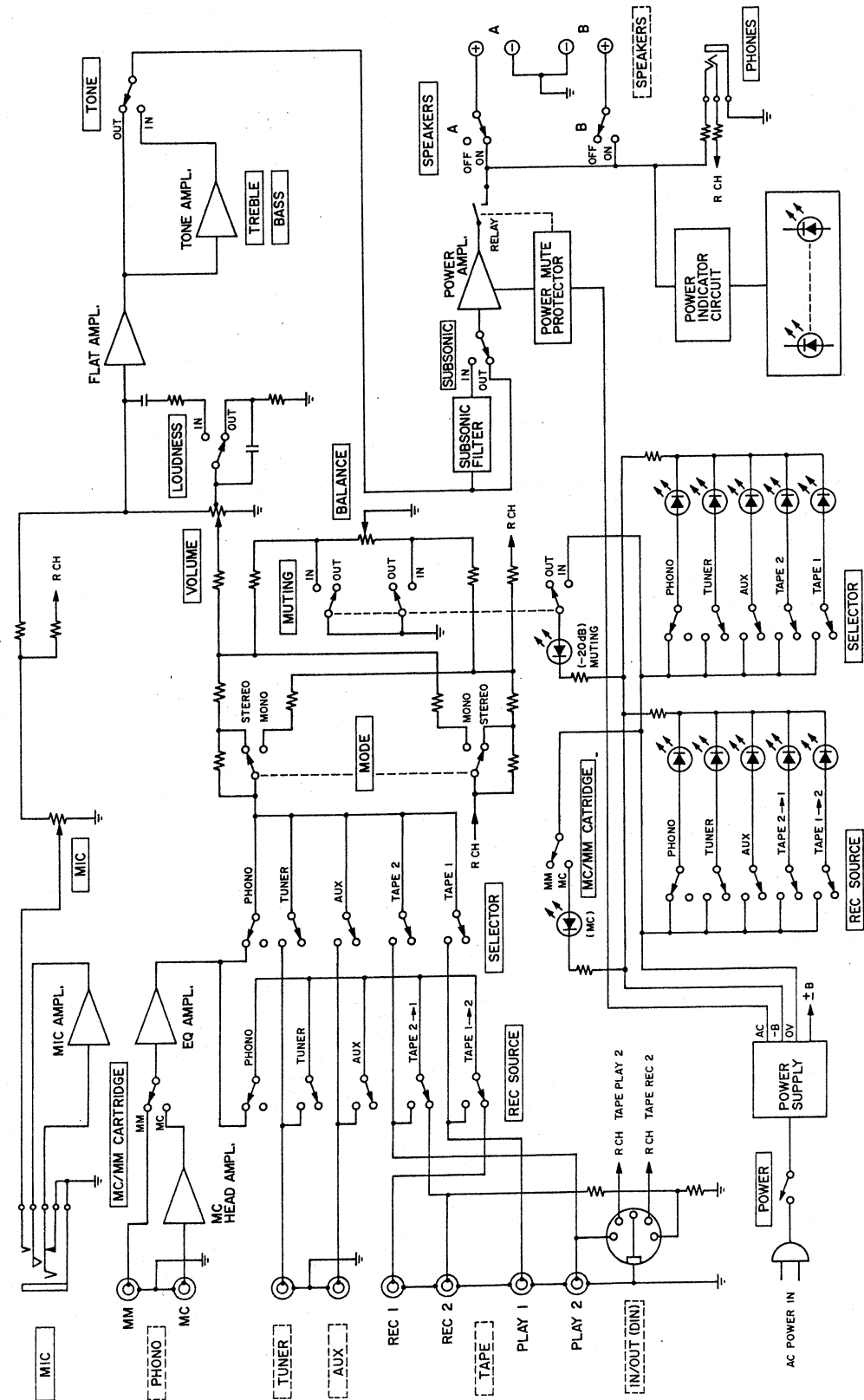

Fig. 5-4 Outline of LED power meter display circuit

6 BLOCK DIAGRAM



7 PARTS LOCATION AND PARTS LIST

PARTS LOCATION-1

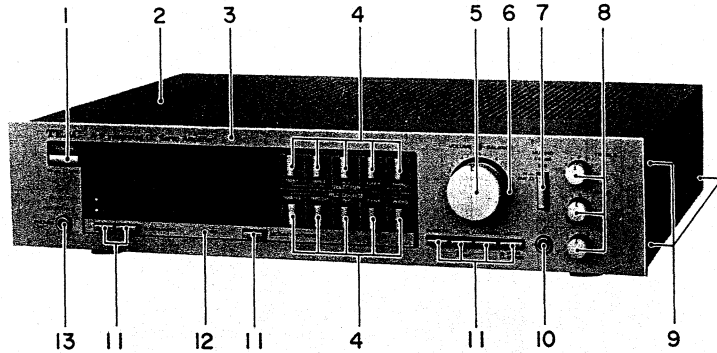

Parts marked with *require longer delivery time.

REF. NO.	PARTS NO.	DESCRIPTION	REMARKS
1 - 1	5800095600	Button, Power	
1 - 2	*5800096801	Cover, Top	
1 - 3	*5800102000	Panel Assy, Front	A-9
	*5800101900	Panel Assy, Front	A-7
1 - 4	5800095700	Button, Selector; B	
1 - 5	5800095001	Knob, Master VR	
1 - 6	5800094101	Knob, VAL VR	
1 - 7	5800095600	Button, Muting	
1 - 8	5800094001	Knob, Sub-VR	
1 - 9	*5783114006	Flange Screw, M4 x 6 (BLK Ni)	
1 - 10	5330007500	Jack, MIC	J004
1 - 11	5800092400	Button, Selector; A	
1 - 12	5225006200	LED, PR5511K	D820
1 - 13	5330007600	Jack, PHONES	J005

PARTS LOCATION-2

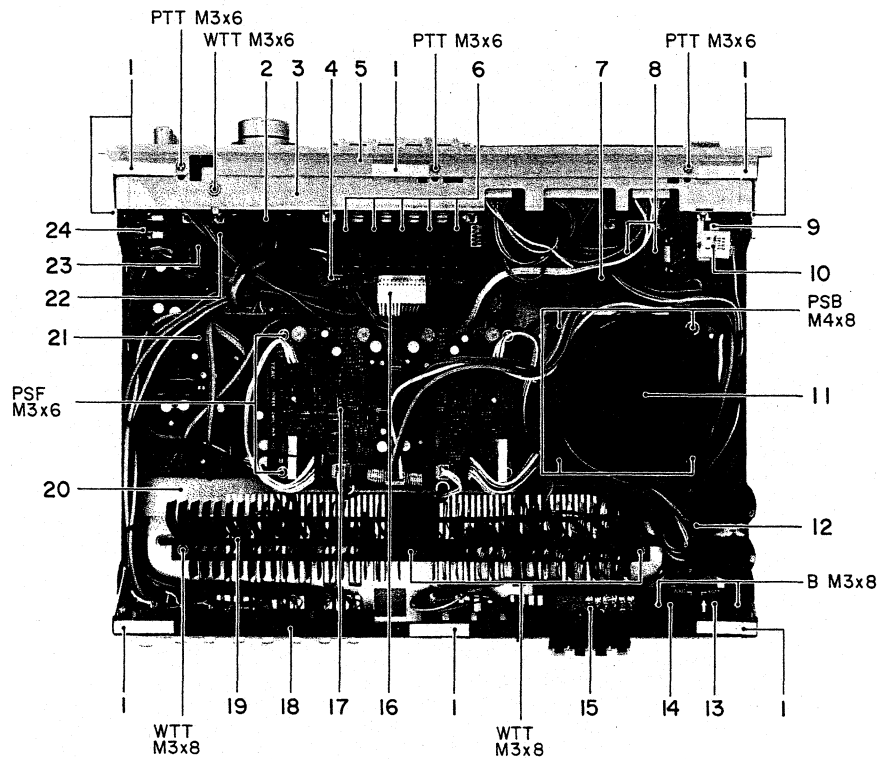

Parts marked with *require longer delivery time.

REF. NO.	PARTS NO.	DESCRIPTION	REMARKS
2 - 1	*5555570000	Cushion, Top Cover; B	
2 - 2	*5200027100	PCB-124 Assy, VOL [US, C]	
	*5200027110	PCB-124 Assy, VOL [All except US, C]	
2 - 3	*5800097801	Chassis, Front	
2 - 4	*5200028700	PCB-102 Assy, SELECTOR [US, C]	
	*5200028710	PCB-102 Assy, SELECTOR [All except US, C]	
2 - 5	*5800102000	Panel Assy, Front	A-9
	*5800101900	Panel Assy, Front	A-7
2 - 6	5300020000	Switch, Push; 4-2 x 5 (5-gang)	S007~S011
2 - 7	*5200027720	PCB-159 Assy, SP SW [US, C]	A-9
	*5200027730	PCB-159 Assy, SP SW [All except US, C]	A-9
	*5200027700	PCB-159 Assy, SP SW [US, C]	A-7
	*5200027710	PCB-159 Assy, SP SW [All except US, C]	A-7
2 - 8	*5300020300	Switch, Push; 4-2 (2-gang)	S017, S018
2 - 9	Δ.*5134112000	Switch, Push (POWER) [US, C, GE]	
	Δ.*5300019400	Switch, Push (POWER) [E, UK, A]	
	Δ.*5134111000	Switch, Push (POWER) [J]	
2 - 10	Δ.*5052906000	Spark Killer, 0.33μF + 120Ω/250V [US]	
	Δ.*5292002800	Spark Killer, 0.033μF + 120Ω/125V [C]	
	Δ.*5292002500	Spark Killer, 0.01μF + 300Ω [GE]	
	Δ.*5267702500	Spark Killer, 0.0047μF/250V [E, UK, A]	
	Δ.*5052913000	Spark Killer, 0.1μF + 120Ω/300V AC [J]	
2 - 11	Δ.*5320005300	Transformer, Power [US, C]	A-9
	Δ.*5320005400	Transformer, Power [GE]	A-9
	Δ.*5320005500	Transformer, Power [E, UK, A]	A-9
	Δ.*5320010300	Transformer, Power [J]	A-9
	Δ.*5320005000	Transformer, Power [US, C]	A-7
	Δ.*5320005100	Transformer, Power [GE]	A-7
	Δ.*5320005200	Transformer, Power [E, UK, A]	A-7
	Δ.*5320001020	Transformer, Power [J]	A-7
2 - 12	*5200027920	PCB-105 Assy, LCR [US, C]	A-9
	*5200027930	PCB-105 Assy, LCR [All except US, C]	A-9
	*5200027900	PCB-105 Assy, LCR [US, C]	A-7
	*5200027910	PCB-105 Assy, LCR [All except US, C]	A-7
2 - 13	Δ.*5133014000	Plug, Voltage Selector [GE]	
2 - 14	Δ.*5132011200	Socket, Voltage Selector [GE]	
2 - 15	*5200028100	PCB Assy, SP Terminal [US, C]	
	*5200028110	PCB Assy, SP Terminal [All except US, C]	
2 - 16	*5122174000	Connector Socket, 12P (WHT)	
2 - 17	*5200028920	PCB-102 Assy, POWER AMPL [US, C]	A-9
	*5200028930	PCB-102 Assy, POWER AMPL [All except US, C]	A-9
	*5200028900	PCB-102 Assy, POWER AMPL [US, C]	A-7
	*5200028910	PCB-102 Assy, POWER AMPL [All except US, C]	A-7
2 - 18	*5800096600	Panel, Rear [US, C, GE, J]	
	*5800096700	Panel, Rear; E [E, UK, A]	
2 - 19	*5800096300	Heatsink, L	
2 - 20	*5800097900	Chassis, Main	
2 - 21	*5200026440	PCB Assy, MOTHER [US]	A-9
	*5200026450	PCB Assy, MOTHER [C]	A-9
	*5200026460	PCB Assy, MOTHER [GE, J]	A-9
	*5200026470	PCB Assy, MOTHER [E, UK, A]	A-9
	*5200026400	PCB Assy, MOTHER [US]	A-7
	*5200026410	PCB Assy, MOTHER [C]	A-7
	*5200026420	PCB Assy, MOTHER [GE]	A-7
	*5200026430	PCB Assy, MOTHER [E, UK, A]	A-7
2 - 22	*5200026900	PCB-104 Assy, MUTING [US, C]	
	*5200026910	PCB-104 Assy, MUTING [All except US, C]	
2 - 23	5300019900	Switch, Push; 4-2	S106
2 - 24	*5200027300	PCB-107 Assy, TONE [US, C]	
	*5200027310	PCB-107 Assy, TONE [All except US, C]	

[US]: U.S.A. [C]: CANADA [GE]: GENERAL EXPORT [E]: EUROPE [UK]: U.K.
 [A]: AUSTRALIA [J]: JAPAN

PARTS LOCATION-3

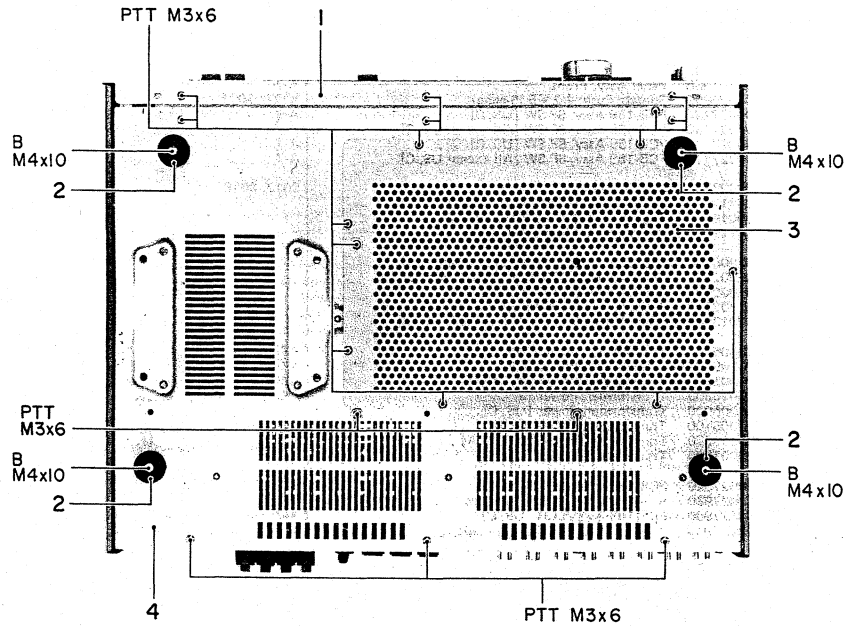

Parts marked with *require longer delivery time.

REF. NO.	PARTS NO.	DESCRIPTION	REMARKS
3 - 1	*5800102000	Panel Assy, Front	A-9
	*5800101900	Panel Assy, Front	A-7
3 - 2	*5800093800	Foot, L	
	*5800093900	Foot, H	
3 - 3	*5800095300	Cover, Bottom	
3 - 4	*5800097900	Chassis, Main	

PARTS LOCATION-4

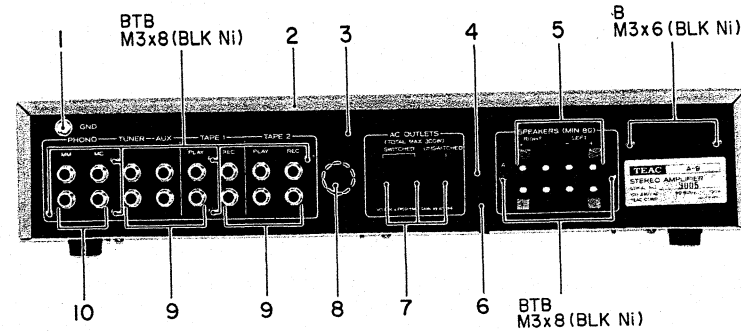

Parts marked with *require longer delivery time.

REF. NO.	PARTS NO.	DESCRIPTION	REMARKS
4 - 1	*5045407100	Terminal GND	
4 - 2	*5800096801	Cover, Top	
4 - 3	*5800096500	Panel, Rear [US, C, GE, J]	
	*5800096700	Panel, Rear; E [E, UK, A]	
4 - 4	*5534660000	Strain Relief, Cord; 4N-4 [All except UK]	
	*5534661000	Strain Relief, Cord; 4K-1 [UK]	
4 - 5	*5327005200	Terminal, Push; SP	J006
4 - 6	Δ 5128075000	Cord, AC Power [US, C, GE]	
	Δ *5128034000	Cord, AC Power [J]	
	Δ 5128047000	Cord, AC Power [UK]	
	Δ 5350008200	Cord, AC Power [E]	
	Δ 5350008300	Cord, AC Power [A]	
4 - 7	Δ *5332010600	Socket, AC Power [US, C, GE, J]	J008~J010
4 - 8	*5334010300	Socket, DIN [E, UK, A]	
4 - 9	*5330505200	Jack, Pin; 6P	
4 - 10	*5330505100	Jack, Pin; 4P	

[US]: U.S.A. [C]: CANADA [GE]: GENERAL EXPORT [E]: EUROPE [UK]: U.K.
 [A]: AUSTRALIA [J]: JAPAN

PARTS LOCATION-5

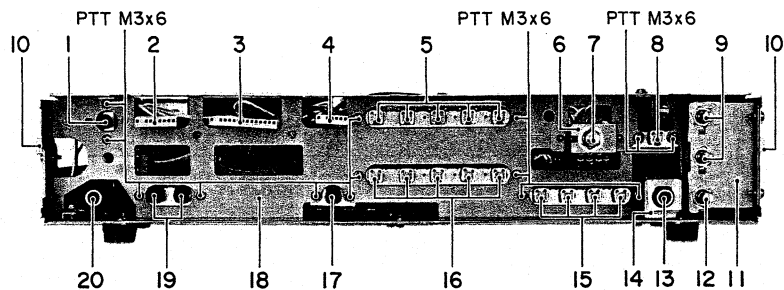

PARTS LOCATION-6

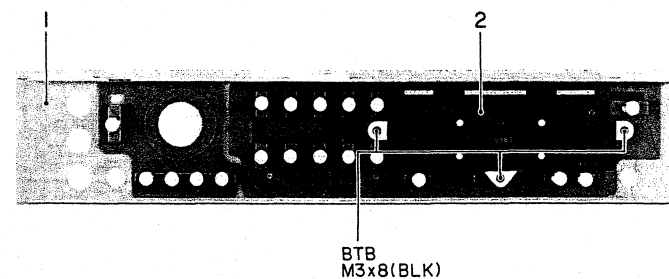

Parts marked with *require longer delivery time.

REF. NO.	PARTS NO.	DESCRIPTION	REMAKRS
6 - 1	*5800102000	Panel Assy, Front	A-9
	*5800101900	Panel Assy, Front	A-7
6 - 2	*5225006100	LED Assy, BU4197	

Parts marked with *require longer delivery time.

REF. NO.	PARTS NO.	DESCRIPTION	REMAKRS
5 - 1	Δ*5134112000	Switch, Push (POWER) [US, C, GE]	
	Δ*5300019400	Switch, Push (POWER) [E, UK, A]	
	Δ*5134111000	Switch, Push (POWER) [J]	
5 - 2	*5122469000	Connector Socket, 8P (WHT)	
5 - 3	*5122486000	Connector Socket, 14P (WHT)	
5 - 4	*5122467000	Connector Socket, 6P (WHT)	
5 - 5	5300020000	Switch, Push, 4-2 x 5 (5-gang)	S007~S011
5 - 6	*5800093300	Holder, VAL VR	
5 - 7	5283502502	Var. Res., 3-gang; 300kΩ (B), 100kΩ (B)	VR41~VR43
5 - 8	*5300019900	Switch, Push, 4-2	S016
5 - 9	5150243000	Var. Res., 50kΩ (B) x 2	VR11, VR21, VR12, VR22
5 - 10	*5555700000	Cushion, Top Cover; B	
5 - 11	*5800093200	Holder, VR	
5 - 12	5282009402	Var. Res., 100kΩ	VR31
5 - 13	*5330007500	Jack, MIC	J004
5 - 14	*5800093400	Holder, Jack	
5 - 15	5300020200	Switch, Push; 4-2 (4-gang)	S012~S015
5 - 16	5300020100	Switch, Push; 4-2 x 5 (5-gang)	S002~S006
5 - 17	5300020400	Switch, Push; 2-2	S001
5 - 18	*5800097801	Chassis, Front	
5 - 19	5300020300	Switch, Push; 4-2 (2-gang)	S017, S018
5 - 20	5330007600	Jack, PHONES	J005

[US]: U.S.A. [C]: CANADA [GE]: GENERAL EXPORT [E]: EUROPE [UK]: U.K.
 [A]: AUSTRALIA [J]: JAPAN

INCLUDED ACCESSORIES

REF. NO.	PARTS NO.	DESCRIPTION	REMAKRS
	5124047000	Pin Plug, Short Circuit x 4	
	5700009700	A-9/A-7 Owner's Manual	

8 PC BOARDS AND PARTS LIST

PC Boards shown viewed from foil side.

MOTHER PCB-116 ASSY

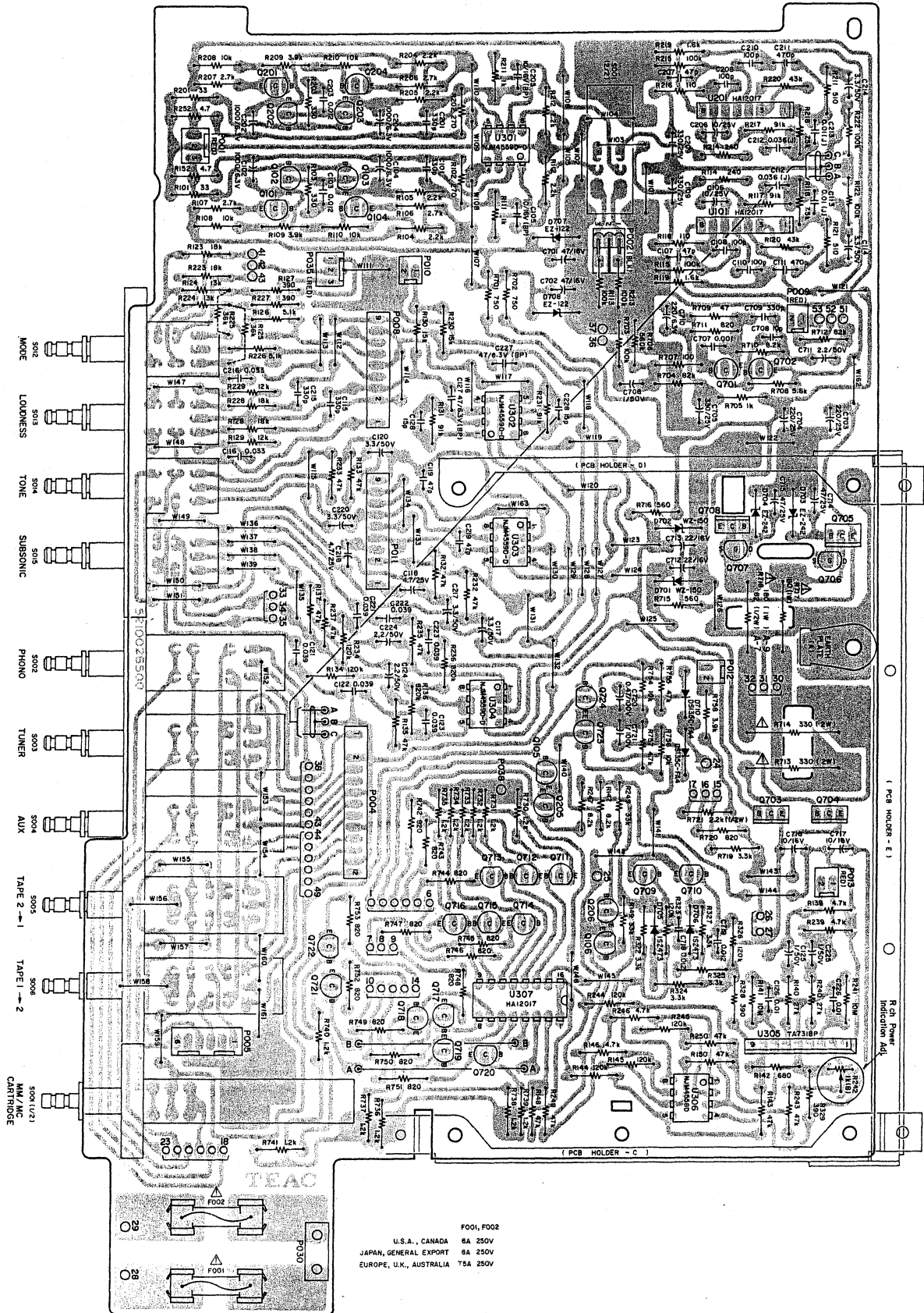

POWER AMPL PCB-102 ASSY

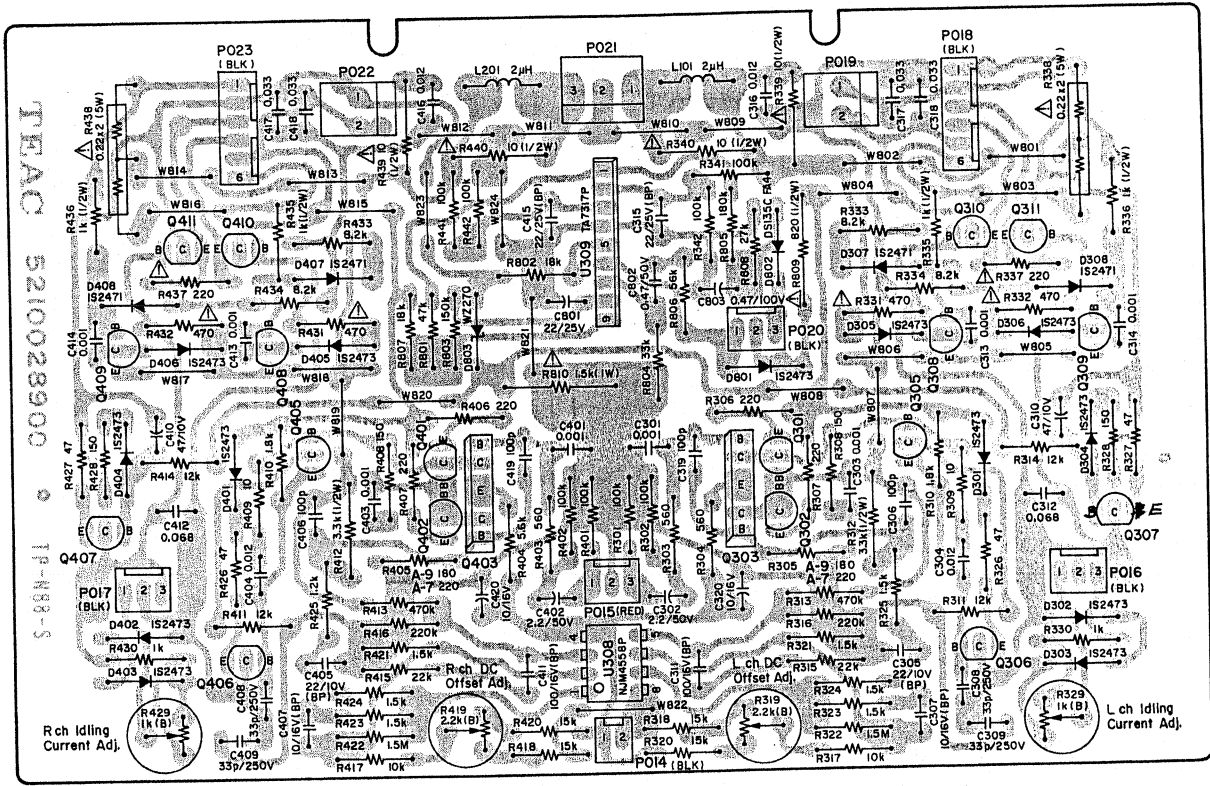

LCR PCB-105 ASSY

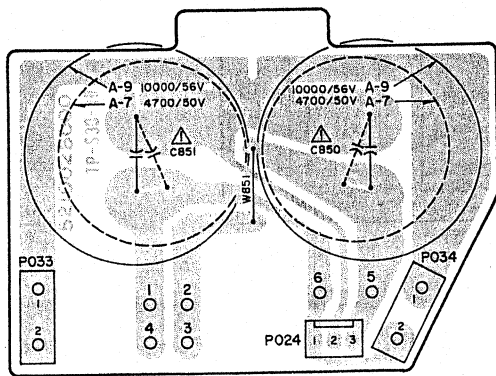

TONE PCB-107 ASSY

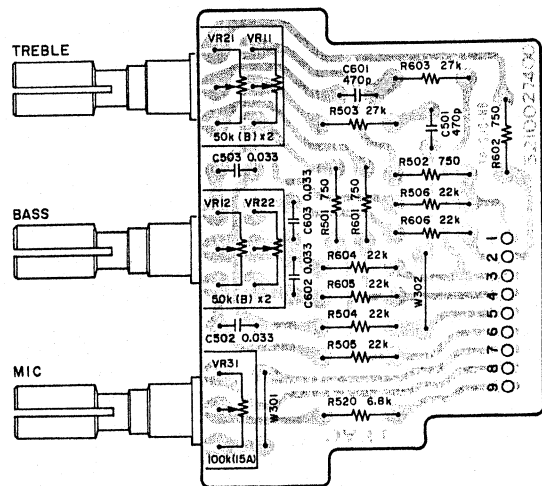

SP SW PCB-159 ASSY

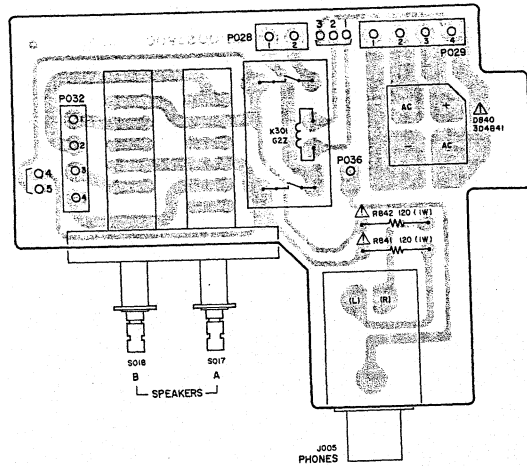

SELECTOR PCB-102 ASSY

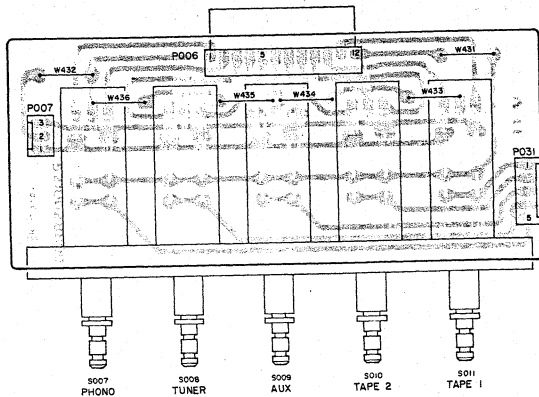

MOTHER PCB-116 ASSY

REF. NO.	PARTS NO.	DESCRIPTION
	5200026440	PCB Assy, A-9 [US]
	5200026450	PCB Assy, A-9 [C]
	5200026460	PCB Assy, A-9 [GE, J]
	5200026470	PCB Assy, A-9 [E, UK, A]
	5200026400	PCB Assy, A-7 [US]
	5200026410	PCB Assy, A-7 [C]
	5200026420	PCB Assy, A-7 [GE, J]
	5200026430	PCB Assy, A-7 [E, UK, A]
	5210026400	PCB-116 [US, C]
	5210026500	PCB-116 [All except US, C]
IC's		
U101, U201	5220406000	HA12017
U301~U304	5147064000	NJM4559D-D
U305	5220405400	TA7318P
U306	5042738000	NJM4558D
U307	5220406100	HA12010
TRANSISTORS		
Q101, Q201	5145149000	2SA970GR
Q102, Q202	5145163000	2SB737S
Q103, Q203	5145164000	2SD786S
Q104, Q204	5145153000	2SC2240GR
Q105, Q205	5145151000	2SC1815GR
Q106, Q206	5145151000	2SC1815GR
Q701	5145153000	2SC2240GR
Q702	5145150000	2SA1015GR
Q703	5231755100	2SD880Y
Q704	5230505700	2SB834Y
Q705	5231755100	2SD880Y
Q706, Q707	5232005200	FET 2SK246GR
Q708	5230505700	2SB834Y
Q709, Q710	5231755800	2SD889R
Q711~Q722	5145151000	2SC1815GR
Q723	5145098000	2SC1741Q
Q724	5145150000	2SA1015GR
DIODES		
D701, D702	5143285000	Zener, WZ-150
D703, D704	5224529702	Zener, EZ-242
D705, D706	5143118000	1S2473HJ
D707, D708	5224527302	Zener, EZ-122
D709, D710	5224013110	DS135CFA4
RESISTORS		
All resistors are rated $\pm 5\%$ tolerance, $\frac{1}{4}$ W and are carbon type unless otherwise noted.		
R101, R201	5183046000	33 Ω
R102, R202	5183068000	270 Ω
R103, R203	5183070000	330 Ω
R104, R204	5183090000	2.2k Ω
R105, R205	5183090000	2.2k Ω
R106, R206	5183092000	2.7k Ω
R107, R207	5183092000	2.7k Ω
R108, R208	5183106000	10k Ω
R109, R209	5183096000	3.9k Ω
R110, R210	5183106000	10k Ω
R111, R211	5183082000	1.0k Ω
R112, R212	5183090000	2.2k Ω
R113, R213	5183130000	100k Ω
R114, R214	5183067000	240 Ω
R115, R215	5183130000	100k Ω
R116, R216	5183059000	110 Ω
R117, R217	5183129000	91k Ω

REF. NO.	PARTS NO.	DESCRIPTION
R118, R218	5183103000	7.5k Ω
R119, R219	5183087000	1.6k Ω
R120, R220	5183121000	43k Ω
R121, R221	5183075000	510 Ω
R122, R222	5183130000	100k Ω
R123, R223	5183112000	18k Ω
R124, R224	5183109000	13k Ω
R125, R225	5183119000	36k Ω
R126, R226	5183099000	5.1k Ω
R127, R227	5183072000	390 Ω
R128, R228	5183112000	18k Ω
R129, R229	5183108000	12k Ω
R130, R230	5183110000	15k Ω
R131, R231	5183129000	91k Ω
R132, R232	5183122000	47k Ω
R133, R233	5183122000	47k Ω
R134, R234	5183132000	120k Ω
R135, R235	5183122000	47k Ω
R136, R236	5183152000	820k Ω
R137, R237	5183122000	47k Ω
R138, R238		(Not used)
R139, R239	5183098000	4.7k Ω
R140, R240	5183116000	27k Ω
R141, R241	5183168000	10M Ω
R142	5183078000	680 Ω
R143, R243	5183122000	47k Ω
R144, R244	5183132000	120k Ω
R145, R245	5183132000	120k Ω
R146, R246	5183098000	4.7k Ω
R147, R247	5183104000	8.2k Ω
R148, R248	5183122000	47k Ω
R149, R249	5183118000	33k Ω
R150, R250	5183122000	47k Ω
R151, R251		(Not used)
R152, R252	5183026000	4.7 Ω
R321		(Not used)
R322	5183094000	3.3k Ω
R323	5183132000	120k Ω
R324	5183094000	3.3k Ω
R325	5183094000	3.3k Ω
R326	5183132000	120k Ω
R327	5183094000	3.3k Ω
R328	5183072000	390 Ω
R329	5183072000	390 Ω
R701	5183079000	750 Ω
R702	5183079000	750 Ω
R703	5183130000	100k Ω
R704	5183128000	82k Ω
R705	5183082000	1.0k Ω
R706	5183148000	560k Ω
R707	5183058000	100 Ω
R708	5183100000	5.6k Ω
R709	5183050000	47 Ω
R710	5183104000	8.2k Ω
R711	5183080000	820 Ω
R712	5183128000	82k Ω
R713	5184803000	330 Ω 2W Metal Film Nonflammable
R714	5184803000	330 Ω 2W Metal Film Nonflammable
R715	5183076000	560 Ω
R716	5183076000	560 Ω

[US]: U.S.A. [C]: CANADA [GE]: GENERAL EXPORT [E]: EUROPE [UK]: U.K.
 [A]: AUSTRALIA [J]: JAPAN

REF. NO.	PARTS NO.	DESCRIPTION
R717	Δ5184761000	180Ω 1W Metal Film Nonflammable
R718	Δ5184761000	180Ω 1W Metal Film Nonflammable
	Δ5181996000	82Ω ½W Metal Film Nonflammable
R719	5183094000	3.3kΩ
R720	5183080000	820Ω
R721	5180090000	2.2kΩ
R722~R729		(Not used)
R730~R741	5183084000	1.2kΩ
R742~R753	5183080000	820Ω
R754	5183060000	10kΩ
R755	5183122000	47kΩ
R756	5183106000	10kΩ
R757	5183098000	4.7kΩ
R758	5183096000	3.9kΩ
CAPACITORS		
C101, C201	5172492000	Polyst. 330pF 50V 10% Heatproof
C102, C202	5173079000	Elec. 1000μF 6.3V
C103, C203	5170497000	Mylar 0.012μF 100V 10%
C104, C204	5173079000	Elec. 1000μF 6.3V
C105, C205	5171482000	Elec. 10μF 16V (BP)
C106, C206	5173011000	Elec. 10μF 25V
C107, C207	5054742000	Dip. Mica 47pF 50V 10%
C108, C208	5172480000	Polyst. 100pF 50V 10% Heatproof
C109, C209	5173084000	Elec. 330μF 25V
C110, C210	5172480000	Polyst. 100pF 50V 10% Heatproof
C111, C211	5172496000	Polyst. 470pF 50V 10% Heatproof
C112, C212	5054477500	Mylar 0.036μF 100V 5%
C113, C213	5054877500	Mylar 0.010μF 100V 5%
C114, C214	5173000000	Elec. 3.3μF 50V
C115, C215	5172492000	Polyst. 330pF 50V 10% Heatproof
C116, C216	5170507000	Mylar 0.033μF 100V 10%
C117, C217	5173000000	Elec. 3.3μF 50V
C118, C218	5173006000	Elec. 4.7μF 50V
C119, C219	5054742000	Dip. Mica 47pF 50V 10%
C120, C220	5173000000	Elec. 3.3μF 50V
C121, C221	5170509000	Mylar 0.039μF 100V 10%
C122, C222	5170509000	Mylar 0.039μF 100V 10%
C123, C223	5170509000	Mylar 0.039μF 100V 10%
C124, C224	5172996000	Elec. 2.2μF 50V
C125, C225	5172992000	Elec. 1μF 50V
C126, C226	5170495000	Mylar 0.010μF 100V 10%
C127, C227	5171495000	Elec. 47μF 6.3V (BP)
C128, C228	5054241000	Dip. Mica 15pF 50V 10%
C701	5173036000	Elec. 47μF 16V
C702	5173036000	Elec. 47μF 16V
C703	5173055000	Elec. 220μF 25V
C704	5173055000	Elec. 220μF 25V
C705	5173064000	Elec. 330μF 25V
C706	5172992000	Elec. 1μF 50V
C707	5170471000	Mylar 0.001μF 100V 10%
C708	5054740000	Dip. Mica 10pF 50V 10%
C709	5172492000	Polyst. 330pF 50V 10% Heatproof

REF. NO.	PARTS NO.	DESCRIPTION
C710	5173052000	Elec. 220μF 6.3V
C711	5172996000	Elec. 2.2μF 50V
C712	5173018000	Elec. 22μF 16V
C713	5173018000	Elec. 22μF 16V
C714	5173037000	Elec. 47μF 25V
C715	5173037000	Elec. 47μF 25V
C716	5173010000	Elec. 10μF 16V
C717	5173010000	Elec. 10μF 16V
C718	5170497000	Mylar 0.012μF 100V 10%
C719	5170497000	Mylar 0.012μF 100V 10%
C720	5172991000	Elec. 0.47μF 100V
C721	5172995000	Elec. 1μF 100V
CONNECTOR PLUGS		
P001	5122300000	3P (RED)
P002	5122203000	3P (BLK)
P004	6052228012	12P (WHT)
P005	5122130000	6P (WHT)
P008	6052228009	9P (WHT)
P009	5122299000	2P (RED)
P010	5122126000	2P (WHT)
P011	6052228000	9P (WHT)
P012	5122126000	2P (WHT)
P013	5122299000	2P (RED)
P030	5122430000	2P Wrapping
P035	5122300000	3P (RED)
SWITCHES		
S001	5300020400	Push, 2-2 N
S001	5300907700	Slide, 2-2 N
	5302100400	Flex Wire, SWR1318
S002~S006	5300020100	Multi, 5-gang 4-2 x 5 N
S012~S015	5300020200	Push 4-gang 2-2 x 4 N
FUSES		
F001, F002	Δ5307004600	6A 250V [US, C]
F001, F002	Δ5307001900	6A 250V [GE, J]
F001, F002	Δ5142193000	T5A 250V [E, UK, A]
	5041237000	Holder, 1P [US, C, GE]
	5142087000	Holder, Small [E, UK, A]
MISCELLANEOUS		
R242	5053350000	Var. Res. 1kΩ (B)
	5800092900	Holder, PCB; C
	5800130000	Holder, PCB; D
	5730000300	Saddle, Wire
	5555590000	Plate, Earth; A
	5800130100	Holder, PCB; E
		(Not included in Assy)

POWER AMPL PCB-102 ASSY

REF. NO.	PARTS NO.	DESCRIPTION
	5200028920	PCB-102 Assy, A-9 [US, C]
	5200028930	PCB-102 Assy, A-9 [All except US, C]
	5200028900	PCB-102 Assy, A-7 [US, C]
	5200028910	PCB-102 Assy, A-7 [All except US, C]
	5210028900	PCB-102 [US, C]
	5210028900	PCB-102 [All except US, C]
IC's		
U308	5042738000	NJM4558D
U309	5220405900	TA7317P
TRANSISTORS		
Q301, Q401	5230013800	2SA992F-E
Q302, Q402	5230013800	2SA992F-E
Q303, Q403	5145154000	2SC2259F
Q305, Q405	5230013800	2SA992F-E
Q306, Q406	5145166000	2SA949Y, A-9
	5145175000	2SB646AC, A-7
Q307, Q407	5145167000	2SC2229Y, A-9
	5145176000	2SD666AC, A-7
Q308, Q408	5230773600	2SC1845F-E
Q309, Q409	5230013800	2SA992F-E
Q310, Q410	5145169000	2SC2235Y, A-9
	5145174000	2SD667AC, A-7
Q331, Q441	5145168000	2SA965Y, A-9
	5145173000	2SB647AC, A-7
DIODES		
D301, D401	5143118000	1S2473HJ
D302, D402	5143118000	1S2473HJ
D303, D403	5143118000	1S2473HJ
D304, D404	5143118000	1S2473HJ
D305, D405	5143118000	1S2473HJ
D306, D406	5143118000	1S2473HJ
D307, D407	5143118000	1S2473HJ
D308, D408	5143118000	1S2473HJ
D801	5143118000	1S2473HJ
D802	5224013100	DS135CFA4
D803	5143300000	Zener, WZ270
RESISTORS		
All resistors are rated ±5% tolerance, ½W and are carbon type unless otherwise noted.		
R301, R401	5183130000	100kΩ
R302, R402	5183130000	100kΩ
R303, R403	5183076000	560Ω
R304, R404	5183100000	5.6kΩ
R305, R405	5183064000	180Ω, A-9
	5183066000	220Ω, A-7
R306, R406	5183066000	220Ω
R307, R407	5183066000	220Ω
R308, R408	5183062000	150Ω
R309, R409	5183034000	10Ω
R310, R410	5183088000	1.8kΩ
R311, R411	5183108000	12kΩ
R312, R412	5185364000	3.3kΩ Metal Film ½W
R313, R413	5183146000	470kΩ
R314, R414	5183108000	12kΩ
R315, R415	5183114000	22kΩ
R316, R416	5183138000	220kΩ
R317, R417	5183106000	10kΩ

REF. NO.	PARTS NO.	DESCRIPTION
R318, R418	5183110000	15kΩ
R320, R420	5183110000	15kΩ
R321, R421	5183086000	1.5kΩ
R322, R422	5183158000	1.5MΩ
R323, R423	5183086000	1.5kΩ
R324, R424	5183086000	1.5kΩ
R325, R425	5183086000	1.5kΩ
R326, R426	5183050000	47Ω
R327, R427	5183050000	47Ω
R328, R428	5183062000	150Ω
R330, R430	5183082000	1kΩ
R331, R431	Δ5184265000	470Ω Nonflammable
R332, R432	Δ5184265000	470Ω Nonflammable
R333, R433	5183104000	8.2kΩ
R334, R434	5183104000	8.2kΩ
R335, R435	5180082000	1kΩ ½W
R336, R436	5180082000	1kΩ ½W
R337, R437	Δ5184257000	220Ω Nonflammable
R338, R438	Δ5241262500	0.22Ω x 2 5W Metal Plate
R339, R439	Δ5185664000	10Ω ½W Nonflammable
R340, R440	Δ5185664000	10Ω ½W Nonflammable
R341, R441	5183130000	100kΩ
R342, R442	5183130000	100kΩ
R801	5183122000	47kΩ
R802	518312000	18kΩ
R803	5183134000	150kΩ
R804	5183118000	33kΩ
R805	5183136000	180kΩ
R806	5183124000	56kΩ
R807	518312000	18kΩ
R808	5183116000	27kΩ
R809	Δ5184777000	820Ω 1W Metal Film Nonflammable
R810	Δ5185794000	1.5kΩ 1W Metal Film Nonflammable
CAPACITORS		
C301, C401	5170471000	Mylar 0.001μF 100V 10%
C302, C402	5172996000	Elec. 2.2μF 50V
C303, C403	5170471000	Mylar 0.001μF 100V 10%
C304, C404	5170497000	Mylar 0.012μF 100V 10%
C305, C405	5171486000	Elec. 22μF 10V (BP)
C306, C406	5172480000	Polyst. 100pF 50V 10% Heatproof
C307, C407	5171482000	Elec. 10μF 16V (BP)
C308, C408	5265211511	Polyst. 33pF 250V 20% Heatproof
C309, C409	5265211511	Polyst. 33pF 250V 20% Heatproof
C310, C410	5173035000	Elec. 47μF 10V
C311, C411	5171502000	Elec. 100μF 16V (BP)
C312, C412	5170515000	Mylar 0.068μF 100V 10%
C313, C413	5170471000	Mylar 0.001μF 100V 10%
C314, C414	5170471000	Mylar 0.001μF 100V 10%
C315, C415	5171488000	Elec. 22μF 25V (BP)
C316, C416	5170497000	Mylar 0.012μF 100V 10%
C317, C417	5170507000	Mylar 0.033μF 100V 10%
C318, C418	5170507000	Mylar 0.033μF 100V 10%
C319, C419	5172480000	Polyst. 100pF 50V 10% Heatproof
C320, C420	5173010000	Elec. 10μF 16V

[US]: U.S.A. [C]: CANADA [GE]: GENERAL EXPORT [E]: EUROPE [UK]: U.K.
[A]: AUSTRALIA [J]: JAPAN

[US]: U.S.A. [C]: CANADA [GE]: GENERAL EXPORT [E]: EUROPE [UK]: U.K.
[A]: AUSTRALIA [J]: JAPAN

REF. NO.	PARTS NO.	DESCRIPTION
C801	5173021000	Elec. 22 μ F 50V
C802	5172990000	Elec. 0.47 μ F 50V
C803	5172991000	Elec. 0.47 μ F 100V
VARIABLE RESISTORS		
R319, R419	5053364000	Semi-fixed 2.2k Ω (B)
R329, R429	5053350000	Semi-fixed 1k Ω (B)
CONNECTOR PLUGS		
P014	5122183000	2P (BLK)
P015	5122300000	3P (RED)
P016, P017	5122184000	3P (BLK)
P018	5122187000	6P (BLK)
P019	5336052200	2P
P020	5122184000	3P (BLK)
P021	5336052300	3P
P022	5336052200	2P
P023	5122187000	6P (BLK)
COILS		
L101, L201	5160050000	Output Phase Compensation

LCR PCB-105 ASSY

REF. NO.	PARTS NO.	DESCRIPTION
5200027920	PCB-105 Assy, A-9 [US, C]	
5200027930	PCB-105 Assy, A-9 [All except US, C]	
5200027900	PCB-105 Assy, A-7 [US, C]	
5200027910	PCB-105 Assy, A-7 [All except US, C]	
5210027900	PCB-105 [US, C]	
5210028000	PCB-105 [All except US, C]	
C850, C851	5262000700	Capacitor, Elec. 10000 μ F 56V A-9
	5262000300	Capacitor, Elec. 4700 μ F 50V A-7
P024	5122127000	Connector Plug, 3P (WHT)
P033, P034	5122480000	Connector Plug, 2P (Wrapping)

TONE PCB-107 ASSY

REF. NO.	PARTS NO.	DESCRIPTION
5200027300	PCB-107 Assy [US, C]	
5200027310	PCB-107 Assy [All except US, C]	
5210027300	PCB-107 [US, C]	
5210027400	PCB-107 [All except US, C]	
CARBON RESISTORS		
All resistors are rated $\pm 5\%$ tolerance and $\frac{1}{4}W$.		
R501, R601	5183079000	750 Ω
R502, R602	5183079000	750 Ω
R503, R603	5183116000	27k Ω
R504, R604	5183114000	22k Ω
R505, R605	5183114000	22k Ω
R506, R606	5183114000	22k Ω
R520	5183102000	6.8k Ω

REF. NO.	PARTS NO.	DESCRIPTION
CAPACITORS-		
C501, C601	5172496000	Polyst. 470pF 50V 10% Heatproof
C502, C602	5170507000	Mylar 0.033 μ F 100V 10%
C503, C603	5170507000	Mylar 0.033 μ F 100V 10%
VARIABLE RESISTORS		
VR11, VR21	5150243000	50k Ω (B) x 2
VR12, VR22	5150243000	50k Ω (B) x 2
VR31	5282009402	100k Ω
	5800093200	Holder, VR

SP SW PCB-159 ASSY

REF. NO.	PARTS NO.	DESCRIPTION
5200027720	PCB-159 Assy A-9 [US, C]	
5200027730	PCB-159 Assy A-9 [All except US, C]	
5200027700	PCB-159 Assy A-7 [US, C]	
5200027710	PCB-159 Assy A-7 [All except US, C]	
5210027700	PCB-159 [US, C]	
5210027800	PCB-159 [All except US, C]	
D840	5143309000	Diode, 3D4B41
D841, R842	5184757000	Resistor, 120 Ω 1W 5% Metal Film Nonflammable
S017, S018	5300020300	Push Switch, 4-2 (2-gang)
K301	5290008000	Relay, 24V G22-4002
J005	5330007600	Jack, PHONES
P028	5122424000	Connector Plug, 2P (Wrapping)
P029	5122476000	Connector Plug, 4P (Wrapping)
P032	5122426000	Connector Plug, 4P (Wrapping)

SELECTOR PCB-102 ASSY

REF. NO.	PARTS NO.	DESCRIPTION
5200028700	PCB-102 Assy [US, C]	
5200028710	PCB-102 Assy [All except US, C]	
5210028700	PCB-102 [US, C]	
5210028800	PCB-102 [All except US, C]	
S007~S011	5300020000	Push Switch, 4-2 (5-gang)
P006	5122158000	Connector Plug, 12P (WHT)
P007	5122127000	Connector Plug, 3P (WHT)
P031	5122129000	Connector Plug, 5P (WHT)

MIC JACK PCB-107 ASSY (PC Board Omitted)

REF. NO.	PARTS NO.	DESCRIPTION
5200026600	PCB-107 Assy [US, C]	
5200026610	PCB-107 Assy [All except US, C]	
5210026600	PCB-107 [US, C]	
5210026700	PCB-107 [All except US, C]	
J004	5330007500	Jack, MIC
P003	5122147000	Connector Plug, 4P (WHT)
	5800093400	Holder, Jack

MUTING PCB-104 ASSY (PC Board Omitted)

REF. NO.	PARTS NO.	DESCRIPTION
5200026900	PCB-104 Assy [US, C]	
5200026910	PCB-104 Assy [All except US, C]	
5210026900	PCB-104 [US, C]	
5210027000	PCB-104 [All except US, C]	
S016	5300019900	Push Switch, 4-2

VOL PCB-124 ASSY (PC Board Omitted)

REF. NO.	PARTS NO.	DESCRIPTION
5200027100	PCB-124 Assy [US, C]	
5200027110	PCB-124 Assy [All except US, C]	
5210027100	PCB-124 [US, C]	
5210027200	PCB-124 [All except US, C]	
VR41~VR43	5283502502	300k Ω (B), 100k Ω (B)

LED PCB-136 ASSY (PC Board Omitted)

REF. NO.	PARTS NO.	DESCRIPTION
5200027500	PCB-136 Assy [US, C]	
5200027510	PCB-136 Assy [All except US, C]	
5210027500	PCB-136 [US, C]	
5210027600	PCB-136 [All except US, C]	
D820	5225006200	LED, PR5511K
	5800093000	Holder, LED PCB
	5534118000	Push Rivet

PTR PCB ASSY (PC Board Omitted)

REF. NO.	PARTS NO.	DESCRIPTION
5200028320	PCB Assy A-9 [US, C]	
5200028330	PCB Assy A-9 [All except US, C]	
5200028300	PCB Assy A-7 [US, C]	
5200028310	PCB Assy A-7 [All except US, C]	
5210028300	PCB [US, C]	
5210028400	PCB [All except US, C]	
Q501, Q601	5230773100	Transistor, 2SC27060 A-9
	5230773400	Transistor, 2SC25630 A-7
Q503, Q603	5230013600	Transistor, 2SA11460 A-9
	5230013300	Transistor, 2SA10930 A-7

BTR PCB ASSY (PC Board Omitted)

REF. NO.	PARTS NO.	DESCRIPTION
5200028500	PCB Assy [US, C]	
5200028510	PCB Assy [All except US, C]	
5210028500	PCB [US, C]	
5210028600	PCB [All except US, C]	
Q502, Q602	5231756200	Transistor, 2SD882Q-P

DIN PCB ASSY [E, UK, A] (PC Board Omitted)

REF. NO.	PARTS NO.	DESCRIPTION
5200026800	PCB Assy [E, UK, A]	
5210026800	PCB [E, UK, A]	
J011	5334010300	Socket, DIN
R551, R651	5183144000	Carbon Res., 390k Ω $\frac{1}{4}W$ 5%
R552, R652	5183130000	Carbon Res., 100k Ω $\frac{1}{4}W$ 5%

[US]: U.S.A. [C]: CANADA [GE]: GENERAL EXPORT [E]: EUROPE [UK]: U.K.
[A]: AUSTRALIA [J]: JAPAN

[US]: U.S.A. [C]: CANADA [GE]: GENERAL EXPORT [E]: EUROPE [UK]: U.K.
[A]: AUSTRALIA [J]: JAPAN

ASSEMBLING HARDWARE CODING LIST

All screws conform to ISO standards, and have crossrecessed heads, unless otherwise noted. ISO screws have the head inscribed with a point as in the figure to the right.



FOR EXAMPLE:

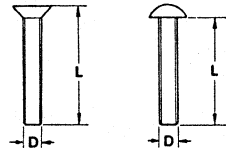
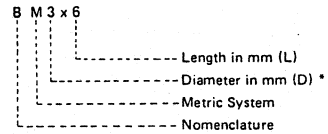

* Inner dia. for washers and nuts

	Code	Name	Type		Code	Name	Type
MACHINE SCREW	R	Round Head Screw		TAPPING SCREW	BTA	Binding Head Tapping Screw(A Type)	
	P	Pan Head Screw			BTB	Binding Head Tapping Screw(B Type)	
	T	Stove Head Screw (Truss)			RTA	Round Head Tapping Screw(A Type)	
	B	Binding Head Screw			RTB	Round Head Tapping Screw(B Type)	
	F	Flat Countersunk Head Screw		SETSCREW	SF	Hex Socket Setscrew(Flat Point)	
	O	Oval Countersunk Head Screw			SC	Hex Socket Setscrew(Cup Point)	
WOOD SCREW	RW	Round Head Wood Screw		SS	Slotted Socket Setscrew(Flat Point)		
TAPTITE SCREW	PTT	Pan Head Taptite Screw		WASHER	E	E-Ring (Retaining Washer)	
	WTT	Washer Head Taptite Screw			W	Flat Washer (Plain)	
SEMS SCREW	BSA	Binding Head SEMS Screw(A Type)			SW	Lock Washer (Spring)	
	BSB	Binding Head SEMS Screw(B Type)			LWI	Lock Washer (Internal Teeth)	
	BSF	Binding Head SEMS Screw(F Type)			LWE	Lock Washer (External Teeth)	
	PSA	Pan Head SEMS Screw(A Type)		TW	Trim Washer (Countersunk)		
	PSB	Pan Head SEMS Screw(B Type)		NUT	N	Hex Nut	

SEMICONDUCTOR ELECTRODES

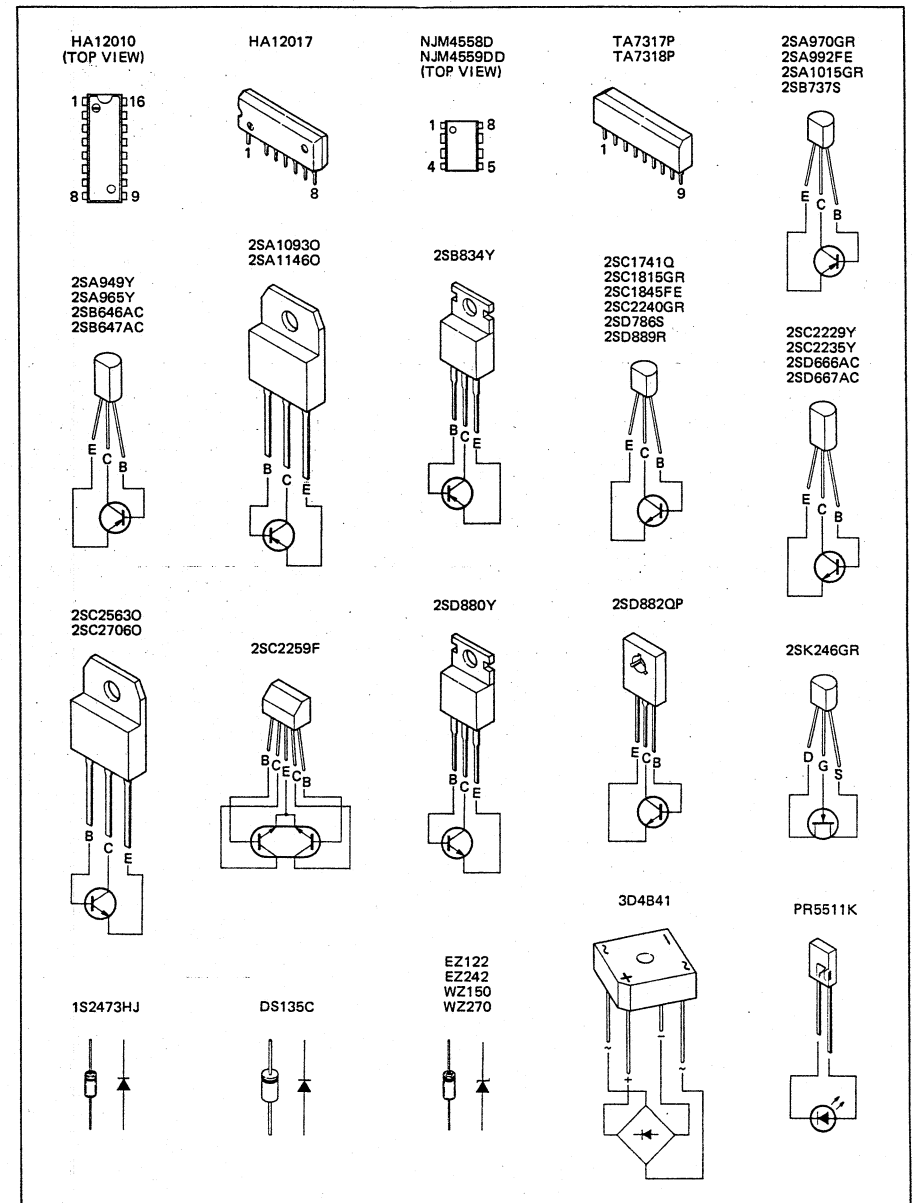

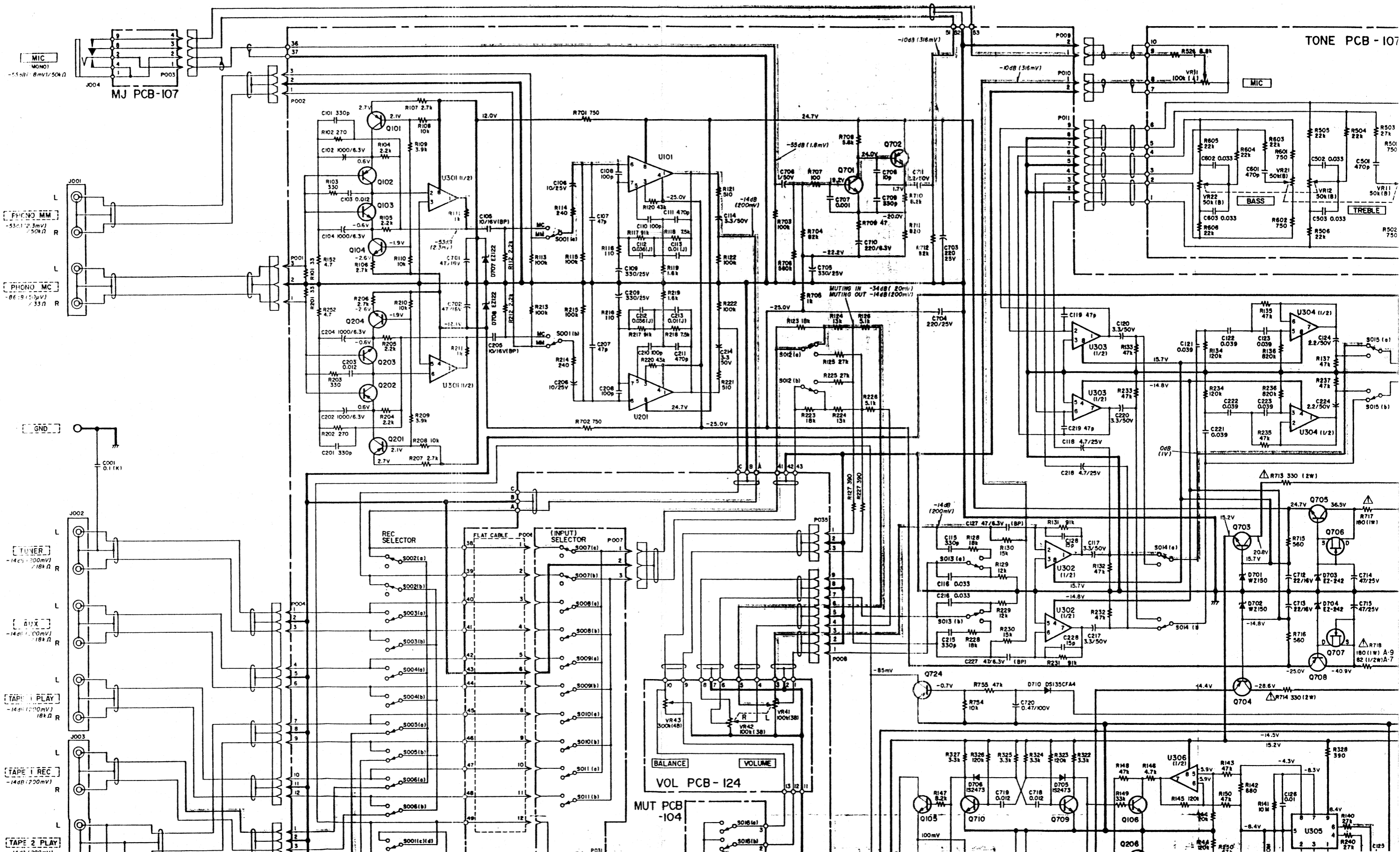

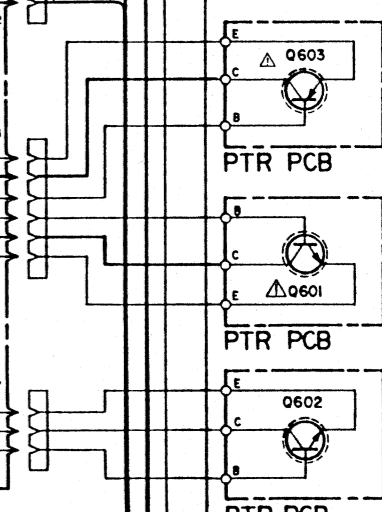
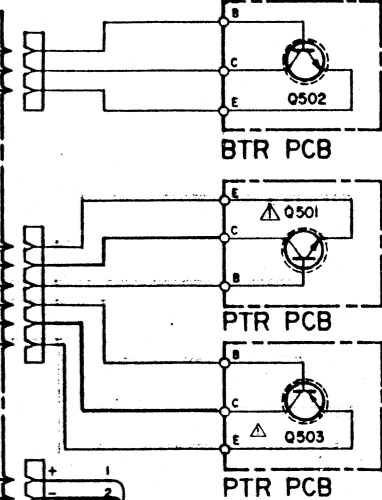
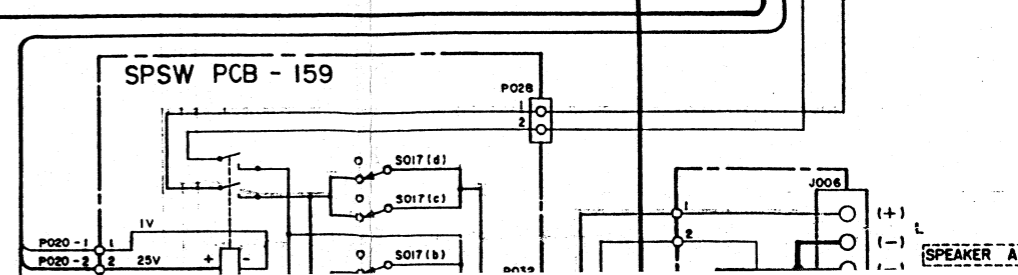
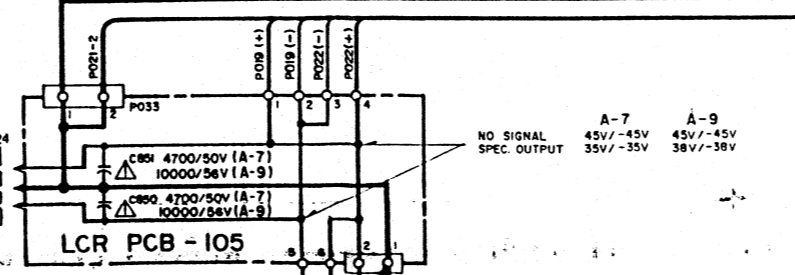
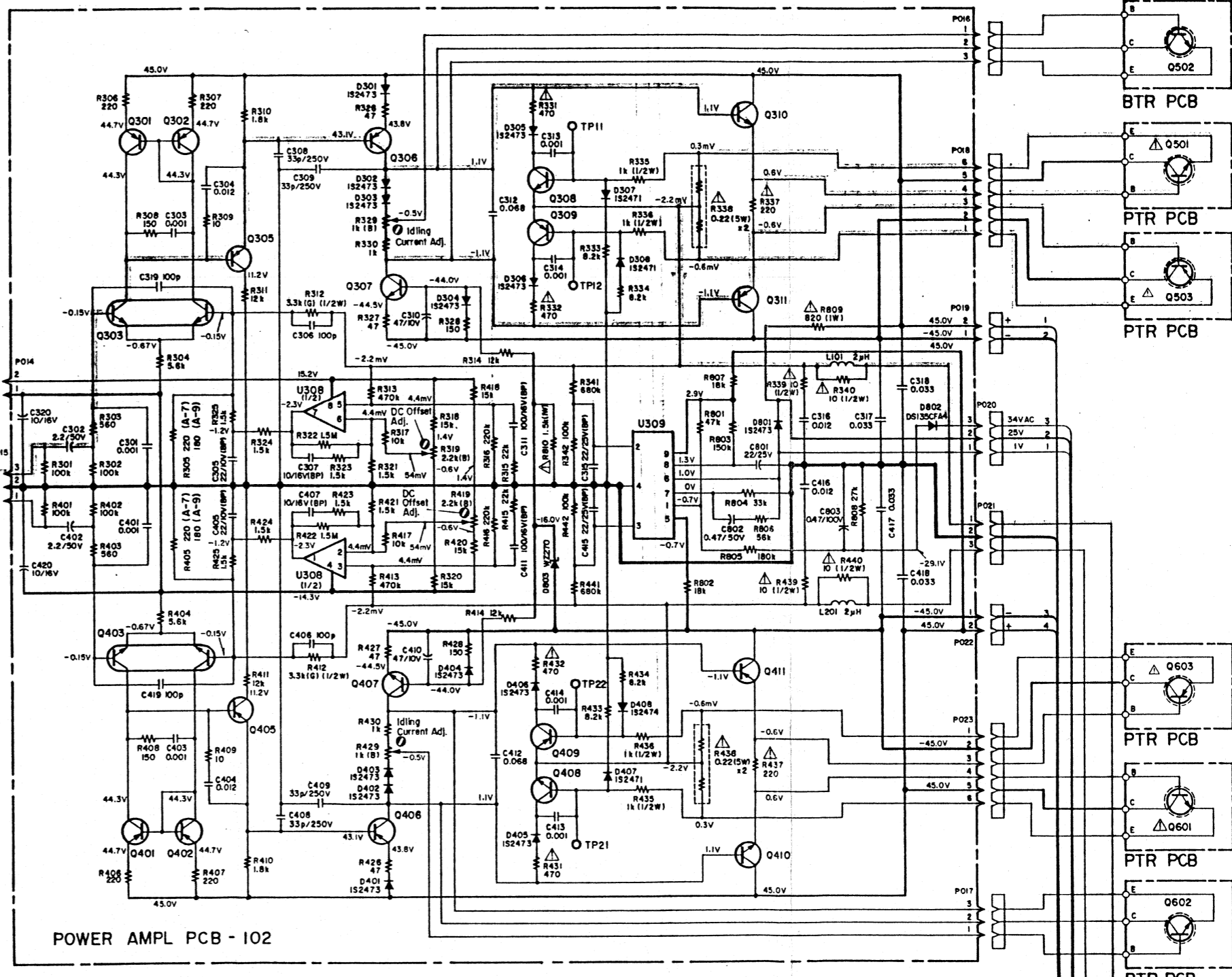
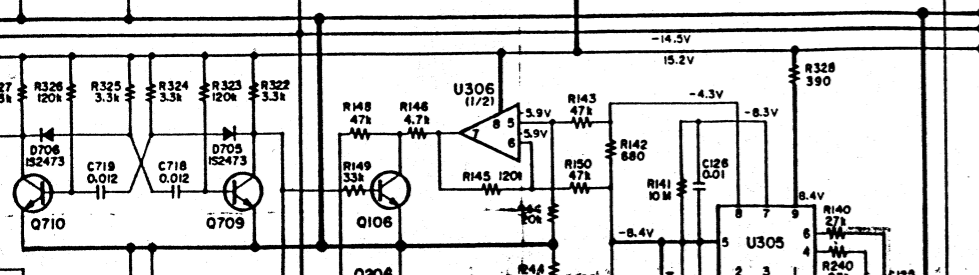
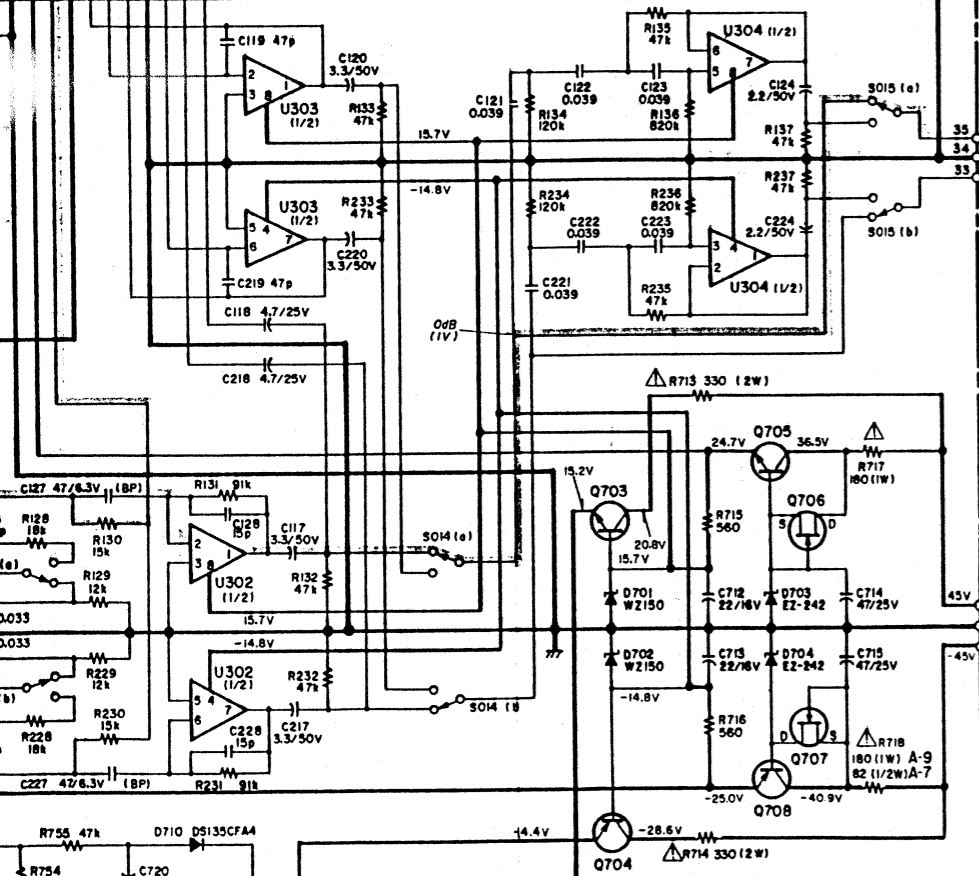
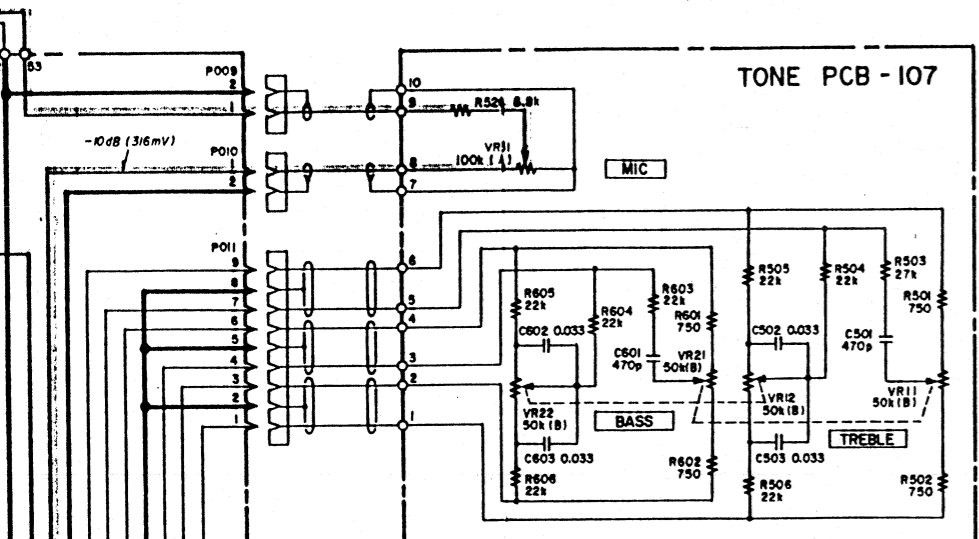

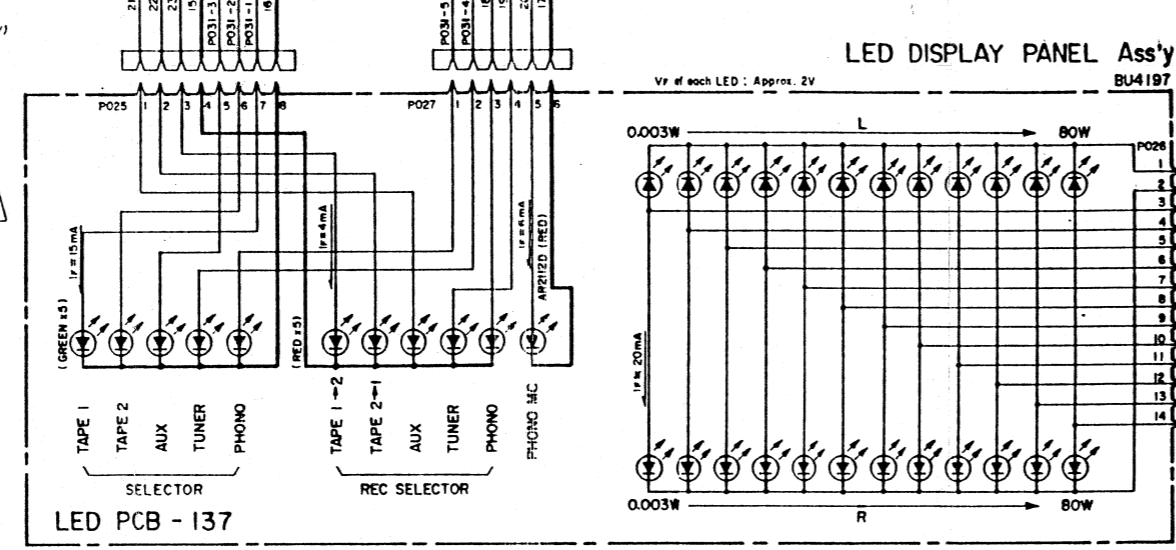
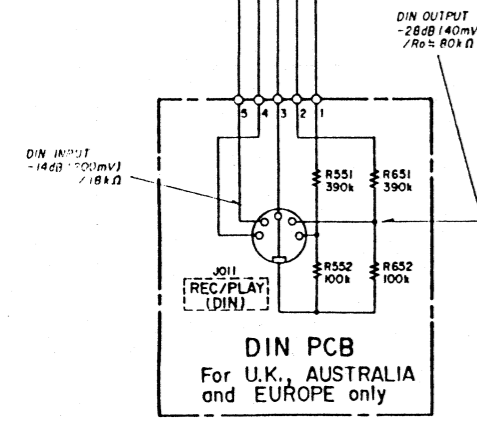
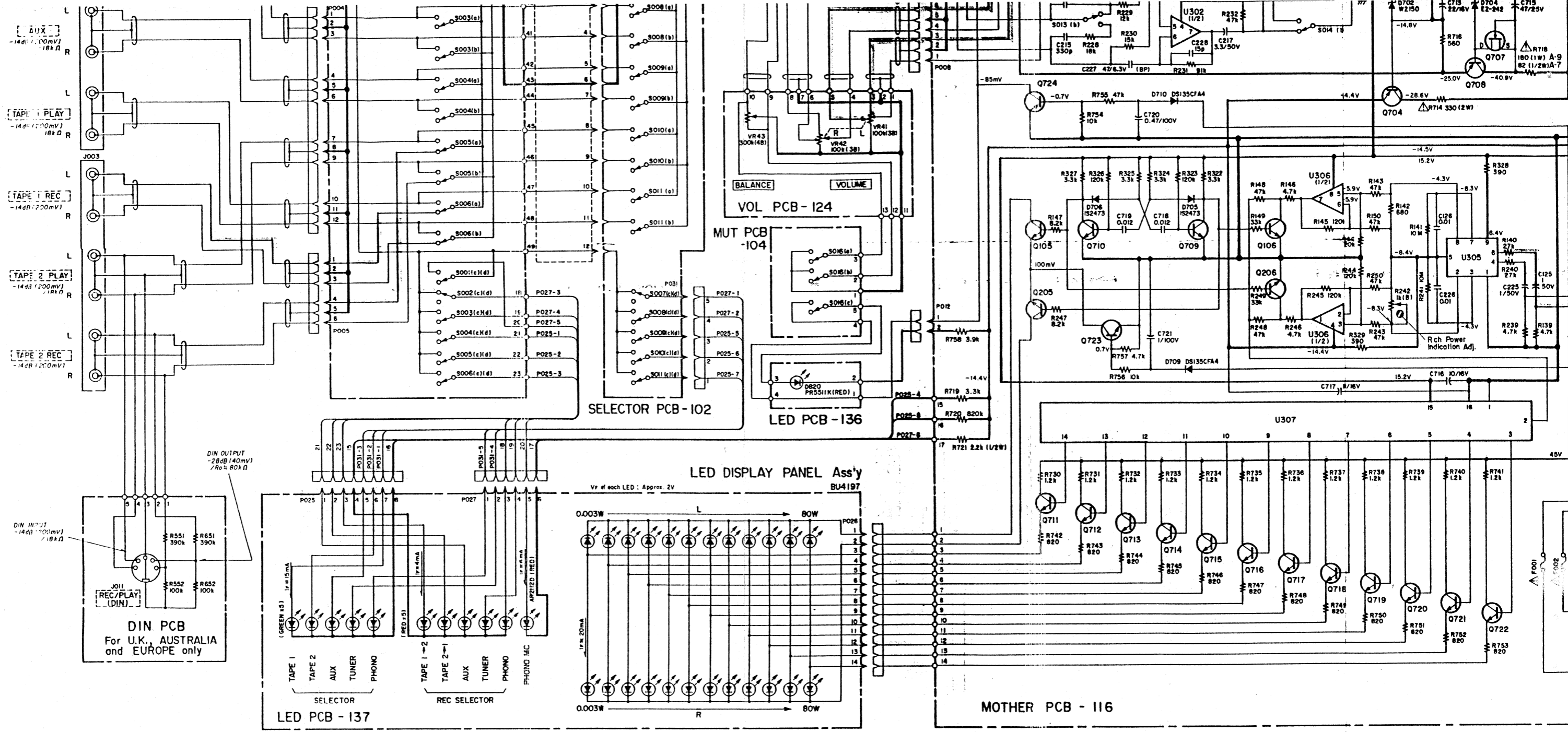

- REC SELECTOR**
- S001 MC/MM CARTRIDGE
 - S002 PHONO
 - S003 TUNER
 - S004 AUX
 - S005 TAPE 2-1
 - S006 TAPE 1-2

- SELECTOR**
- S007 PHONO
 - S008 TUNER
 - S009 AUX
 - S010 TAPE 2
 - S011 TAPE 1

(S001: MM position)
 (S002, S007, S017: ON position)
 (S012: STEREO position)
 (Others: OFF or OUT position)

MOTHER PCB

- U101/U201 HA12017
- U301~U304 NJM4559D-D
- U305 TA7318P
- U306 NJM4558D
- U307 HA12010
- Q101/Q201 2SA970-GR
- Q102/Q202 2SB737(S) or (R)
- Q103/Q203 2SD786(S) or (R)
- Q104/Q204 2SC2240-GR
- Q105/Q205 2SC1815-GR
- Q106/Q206 2SC1815-GR
- Q701 2SC2240-GR
- Q702 2SA1015-GR
- Q703 2SD880-Y
- Q704 2SB834-Y
- Q705 2SD880-Y
- Q706, Q707 2SK246-GR
- Q708 2SB834-Y
- Q709, Q710 2SD889R
- Q711~Q722 2SC1815-GR
- Q723 2SC1741Q
- Q724 2SA1015-GR

POWER AMPL PCB

- U308 NJM4558D
- U309 TA7317P
- Q301/Q401 2SA992(F) - (E)
- Q302/Q402 2SA992(F) - (E)
- Q303/Q403 2SC2259(F)
- Q305/Q405 2SA992(F) - (E)
- Q306/Q406 2SB646A(C) A-7
2SA949-Y A-9
- Q307/Q407 2SD666A(C) A-7
2SC2229-Y A-9
- Q308/Q408 2SC1845(F) - (E)
- Q309/Q409 2SA992(F) - (E)
- Q310/Q410 2SD667A(C) A-7
2SC2235-Y A-9
- Q311/Q411 2SB647A(C) A-7
2SA965-Y A-9

- Q501/Q601 2SC2563-0 A-7
2SC2706-0 A-9
- Q502/Q602 2SD882(Q) - (P)
- Q503/Q603 2SA1093-0 A-7
2SA1146-0 A-9

F001, F002 FUSE

A-7	U.S.A., CANADA	5307004600	6A 250V
	EX, JAPAN	5307001900	6A 250V
	EUR. UK. AUS	5142193000	T5A 250V
A-9	U.S.A., CANADA	5307004600	6A 250V
	EX, JAPAN	5307001900	6A 250V
	EUR. UK. AUS	5142193000	T5A 250V

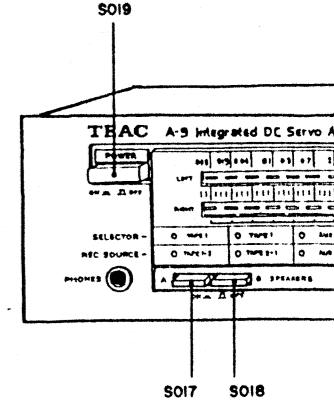

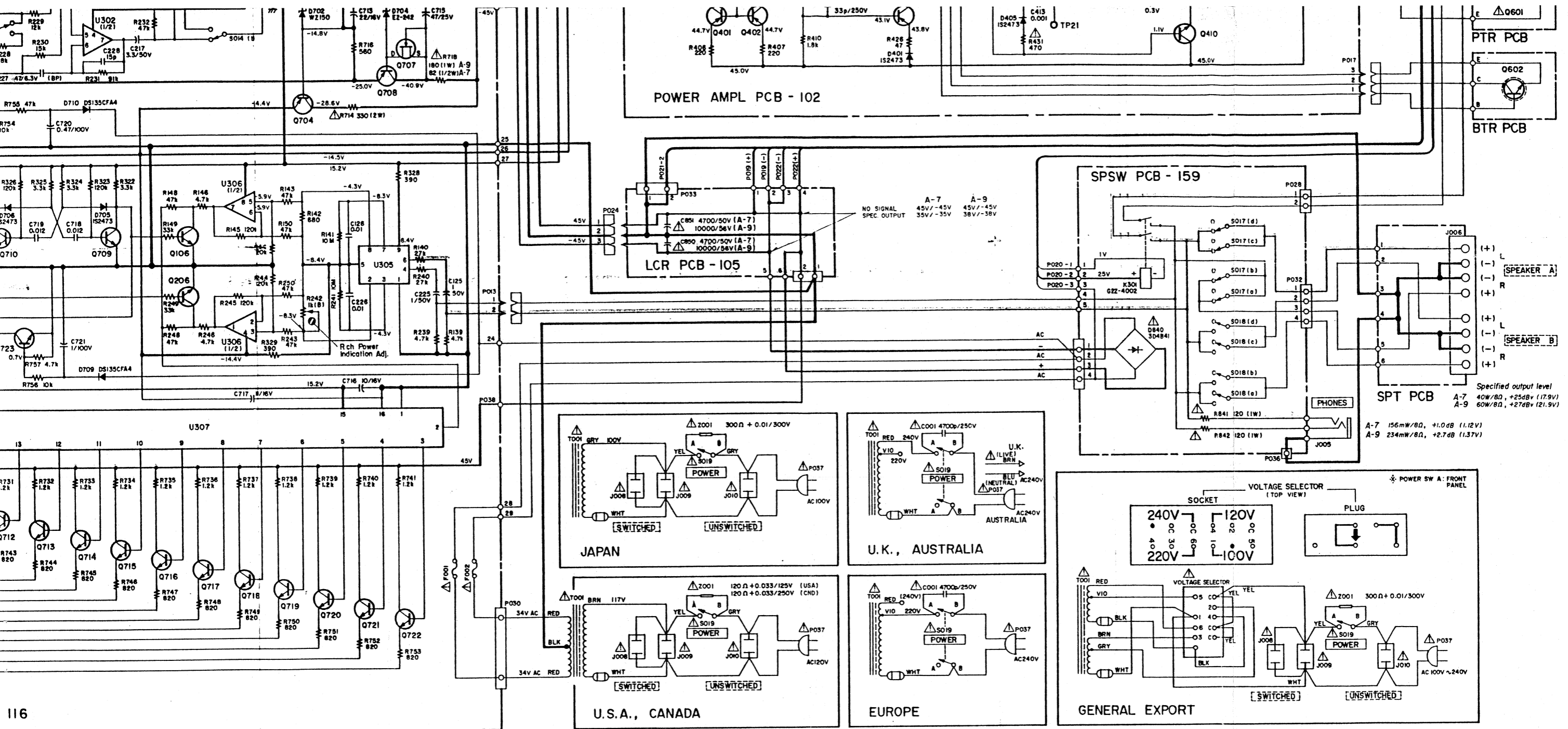

116

FO01, FO02 FUSE

A-7	U.S.A., CANADA	5307004600	6A 250V
	EX, JAPAN	5307001900	6A 250V
	EUR. UK. AUS	5142193000	T5A 250V
A-9	U.S.A., CANADA	5307004600	6A 250V
	EX, JAPAN	5307001900	6A 250V
	EUR. UK. AUS	5142193000	T5A 250V

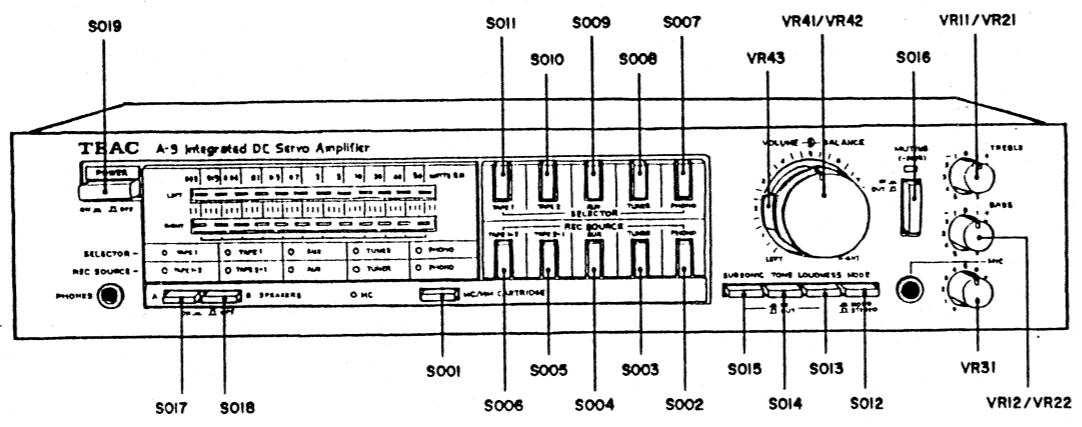

NOTES

- All resistors are 1/4W, ±5%, unless otherwise noted. Resistor values are in ohms (k=kilo-ohms, M=mega-ohms). (G) : ±2% tolerance
- All capacitor values are in microfarads (p=pico-farads). (BP) : bipolar capacitor (J) : ±5% tolerance
- The DC voltages given in each portion are reference values measured under no-signal conditions.
- △ Parts marked with this sign are safety critical components. They must always be replaced with identical components - refer to the appropriate parts list and ensure exact replacement.
- : +B power supply
- : -B power supply
- : Audio signal path (shown for L ch only)
- : Front panel indication
- : Rear panel indication

SELECTOR PCB-102 ASSY

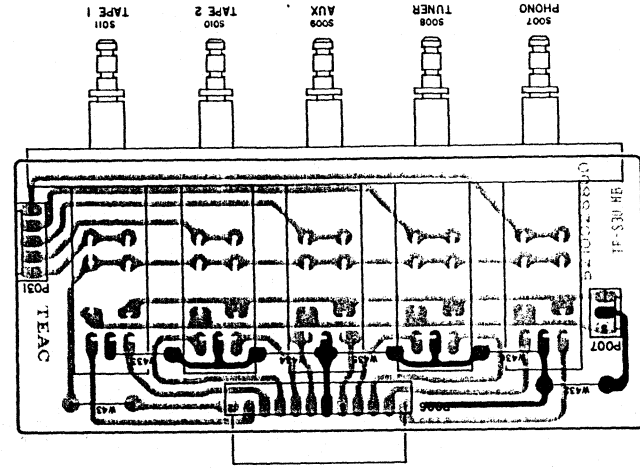

SP SW PCB-159 ASSY

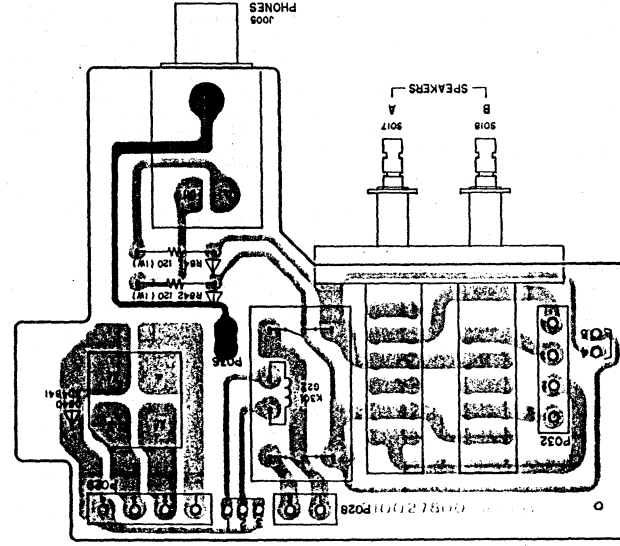

NOTES

1. PC Boards shown viewed from foil side.
 2. The following PC Boards are omitted:

- MJ PCB-107
- MUT PCB-104
- DIN PCB
- VOL PCB-124
- PTR PCB
- BTR PCB

3. All resistors are 1/2 W, ±5%, unless otherwise noted.

4. All capacitor values are in ohms (k = kilo - ohms, M = mega - ohms).

5. All capacitor values are in microfarads (p = pico - farads).

(BP) : bipolar capacitor

5. Δ Parts marked with this sign are safety critical components. They must always be replaced with identical components — refer to the appropriate parts list and ensure exact replacement.

6. The colors used on the PC Board illustrations have the following significance:

- : +B power supply circuit.
- : -B power supply circuit.
- : GND
- : Other

PC BOARDS

TONE PCB-107 ASSY

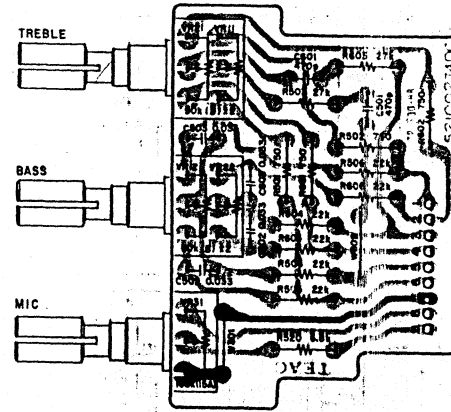

POWER AMPL PCB-102 ASSY

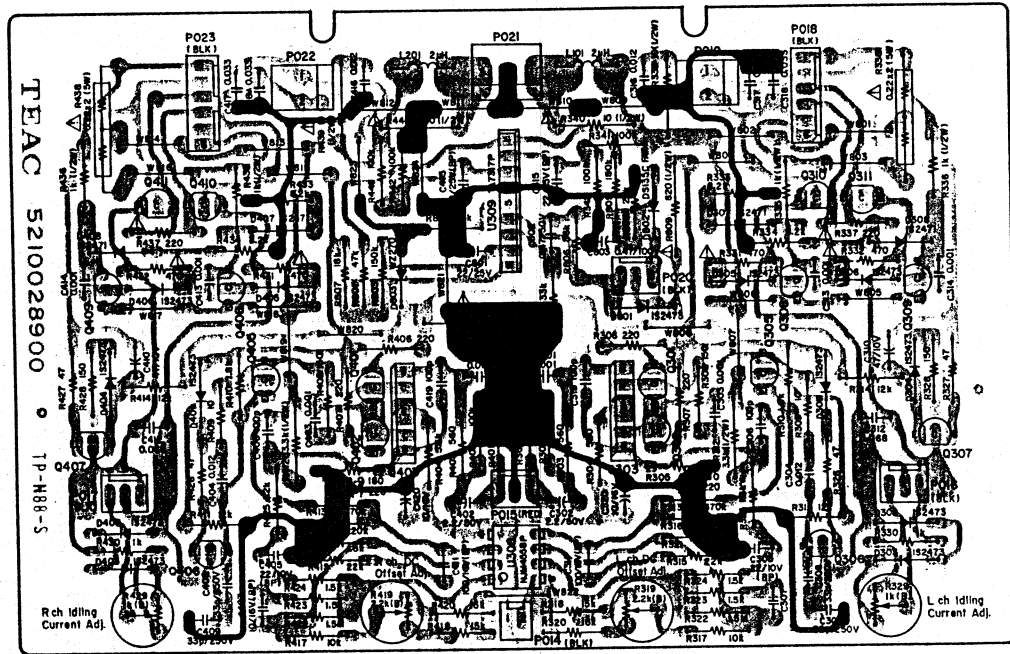

LCR PCB-105 ASSY

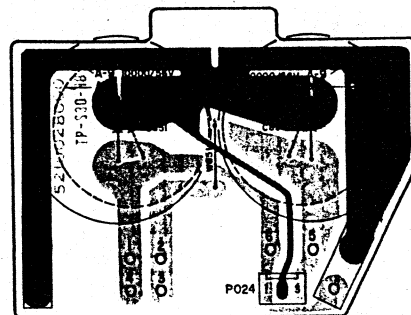

MOTHER PCB ASSY

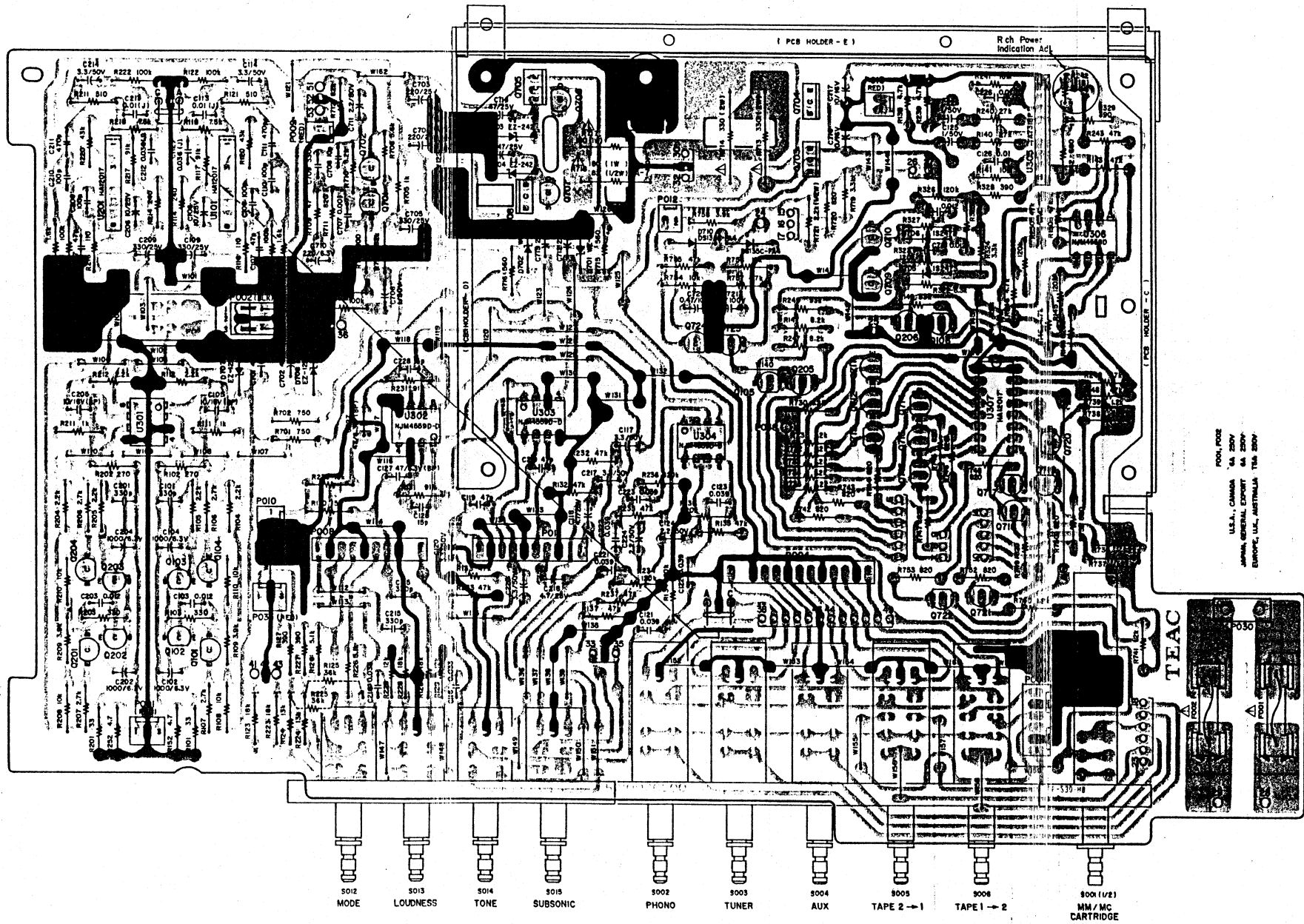

TEAC TECHNICAL INFORMATION

A-9/A-7 Amplifier, Power Transistor

NO. 8302
DATE 27 January 1983

When the captioned amplifiers are used under unstable AC power source, the power transistors could occasionally be damaged. To cope with this kind of problem, more durable power transistors have been prepared. In case the damage of power transistors is experienced, replacing them as well as their peripheral circuit component is suggested. When mounting new power transistors Q501/Q601 Q503/Q603 on the heatsink, ensure that these transistors are precisely placed on the insulation film and the collector is not touching the ground. Hereunder is the list of replacement parts and the related circuit.

Ref No	Original	To be replaced with
Q501/Q601	2SC2706(O), A-9	2SC3280(O) 52307798-00
	2SC2563(O), A-7	2SC3280(O) 52307798-00
Q503/Q603	2SA1146(O), A-9	2SA1301(O) 52300180-00
	2SA1093(O), A-7	2SA1301(O) 52300180-00
Q308/Q408	2SC1845F-E	2SC1844F 51451190-00
Q309/Q409	2SA992F-E	2SA991F 51451170-00
R331/R431	470 Ohm, 1/4 W	To be shorted.
R332/R432	470 Ohm, 1/4 W	To be shorted.
R333/R433	8.2 Kohm, 1/4 W	12 Kohm, 1/4 W
R334/R434	8.2 Kohm, 1/4 W	12 Kohm, 1/4 W
R335/R435	1 Kohm, 1/2 W	470 Ohm, 1/2 W
R336/R436	1 Kohm, 1/2 W	470 Ohm, 1/2 W

