

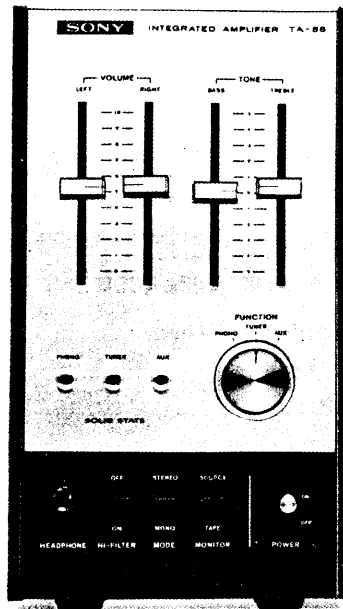

Set using ISO screws

TA-88

UK and AEP Model



SPECIFICATIONS

POWER AMPLIFIER SECTION

- Dynamic power:** 60 watts, both channels operating; 4 ohms.
40 watts, both channels operating; 8 ohms.
- RMS power:** 18 watts, per channel, both channels operating; 4 ohms.
13 watts, per channel, both channels operating; 8 ohms.
- Rated output:** 11 watts per channel, both channels operating; 8 ohms.
- Power band width:** 20 Hz to 20 kHz, IHF
- Harmonic distortion:** Less than 1.0% at rated output (at 1 kHz)
- IM distortion:** Less than 1.0% at rated output

PREAMPLIFIER SECTION

- Frequency response:** PHONO: RIAA curve ± 1.0 dB
TUNER, AUX } 15 Hz to 15 kHz
TAPE } ± 3 dB
REC/PB (input)

- Input sensitivity and impedance:** PHONO: 3 mV 50 k ohms
TUNER, AUX } 250 mV
TAPE } 50 k ohms
REC/PB (input)

- Signal output and output impedance:** REC OUT: 250 mV 10 k ohms
HEADPHONE OUT: 280 mV 270 ohms
REC/PB (output): 30 mV 80 k ohms

GENERAL

- Power consumption:** 80 watts
- Power requirement:** 110, 127, 220, 240 V 50/60 Hz, ac
- Dimensions:** 130 mm (width) x 230 mm (height) x 165 mm (depth)
- Net weight:** 3.2 kg (7 lb 1 oz)
- Shipping weight:** 3.8 kg (8 lb 6 oz)

SONY®

SERVICE MANUAL

TABLE OF CONTENTS

	<u>Title</u>	<u>Page</u>
SECTION 1. TECHNICAL DESCRIPTION		
1-1.	Technical Specifications	1
1-2.	Circuit Description Digest	2
1-3.	Level Diagram	4
1-4.	Block Diagram	5
SECTION 2. DISASSEMBLY AND REPLACEMENT PROCEDURES		
2-1.	Hardware Identification Guide	6
2-2.	Wooden Case Removal	7
2-3.	Front Panel Removal	7
2-4.	Front Subchassis Removal	7
2-5.	Control and Switch Replacement	8
2-6.	Power Amplifier/Power Supply Board Removal	8
2-7.	Power Transistor Replacement	9
2-8.	Rear Panel Removal	9
2-9.	Replacement of Components Secured to the Rear Panel by Nylon Rivets	10
2-10.	Chassis Layout	10
SECTION 3. REPACKING		
		11
SECTION 4. DIAGRAMS		
4-1.	Mounting Diagram - Attenuator Board -	12
4-2.	Mounting Diagram - Preamplifier Board -	13
4-3.	Mounting Diagram - Power Amplifier/Power Supply Board -	14
4-4.	Schematic Diagram	15
SECTION 5. EXPLODED VIEWS		
		17
SECTION 6. ELECTRICAL PARTS LIST		
		19

SECTION 1 TECHNICAL DESCRIPTION

1-1. TECHNICAL SPECIFICATIONS

Technical specifications for the TA-88 are listed in Table 1-1.

**TABLE 1-1.
TA-88 TECHNICAL SPECIFICATIONS**

Power Amplifier Section

Dynamic power:	60 watts, both channels operating; 4 ohms. 40 watts, both channels operating; 8 ohms.
RMS power:	18 watts, per channel, both channels operating; 4 ohms. 13 watts, per channel, both channels operating; 8 ohms.
Rated output:	11 watts, per channel, both channels operating; 8 ohms.
Power band width:	20 Hz to 20 kHz, IHF
Harmonic distortion:	Less than 1.0% at rated output (at 1 kHz)
IM distortion:	Less than 1.0% at rated output
Residual noise:	Less than 1.5 μ W (8 ohms)

Preamplifier Section

Frequency response:	PHONO: RIAA curve \pm 1.0 dB TUNER, AUX } 15 Hz to TAPE } 50 kHz REC/PB (input) } \pm 3 dB
---------------------	---

Input sensitivity and impedance:

PHONO:	3 mV 50 k ohms
TUNER, AUX	} 250 mV 50 k ohms
TAPE	
REC/PB (input)	

Signal output and output impedance:

REC OUT:	250 mV 10 k ohms
HEADPHONE OUT:	280 mV 270 ohms
REC/PB (output):	30 mV 80 k ohms

Signal-to-noise ratio:

PHONO:	greater than 60 dB (weighting network "B")
TUNER, AUX	} greater than 80 dB (weighting network "A")
TAPE	
REC/PB (input)	

Tone controls:

BASS:	\pm 10 dB at 100 Hz
TREBLE:	\pm 10 dB at 1 kHz

Filters:

HIGH:	6 dB/oct, above 5 kHz
-------	-----------------------

General

Power consumption:	80 watts
Power requirement:	110, 127, 220, 240 V 50/60 Hz, ac
Dimensions:	130 mm (width) \times 230 mm (height) \times 165 mm (depth)
Net weight:	3.2 kg (7 lb 1 oz)
Shipping weight:	3.8 kg (8 lb 6 oz)

1-2. CIRCUIT DESCRIPTION DIGEST

Pre-amplifier Section

Equalizer Amplifier Q101, Q102 This direct-coupled two stage amplifier amplifies the small signal produced by the tuner, phono cartridge, tape recorder, or signal applied to the AUX input jacks, to the level required at the input of the following buffer amplifier.

VOLUME control RV101 The equalized phono signals and signals applied to the other input terminals are fed to the volume control through the MONITOR and MODE switches. The level of the signal applied to the following tone control circuit is determined by the setting of RV101 shown in Fig. 1-1.

Buffer Amplifier (Emitter follower); Q103 This isolates the volume control and tone control to eliminate mutual interference shown in Fig. 1-1. The tone control circuit employed is a modified negative-

feedback type utilizing the power amplifier itself.

Note that the output of power amplifier is fed back to the RV102 through R202 shown in Fig. 1-1.

HI-FILTER switch (S4)

The high-cut off filter (R117 and C109) eliminates unwanted high frequency components (5 kHz and higher) from the input signal when this switch is ON, shown in Fig. 1-1.

Power Amplifier Section

Pre-amplifier Q201, Q202 Q201 and Q202 form a para-phase amplifier but signal output is extracted from the collector circuit of Q202. This circuit has a various advantages in direct coupling systems.

One is high stability despite temperature variations and another is high input impedance without reducing the amplifier's gain.

The ac output appears across

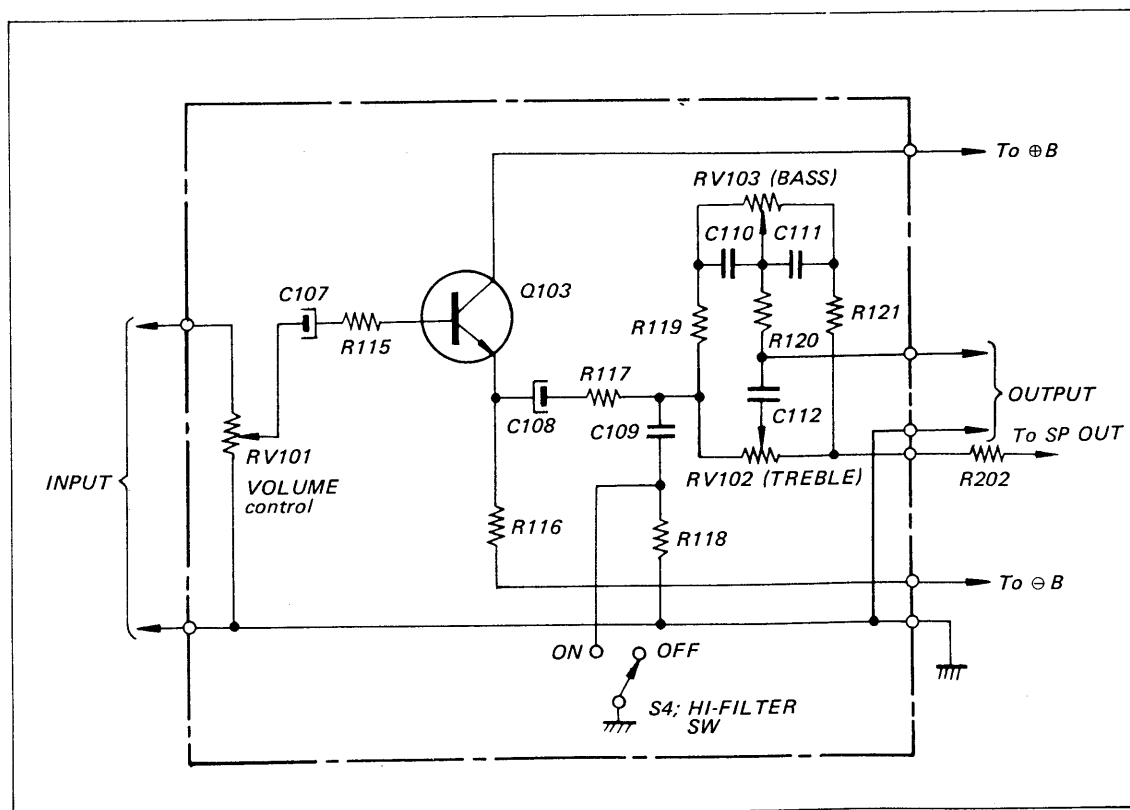

Fig. 1-1. Partial schematic diagram of tone control circuit

load resistor R208 (1.2 k) in the collector circuit of Q202. An emitter decoupling circuit is formed by the emitter-base resistance of Q202. R209 in the base circuit of Q202.

Common emitter resistor R206 keeps the dc current flow constant in the Q201 and Q202, thus increasing dc stability.

Predriver
Q203

This stage is a conventional flat amplifier, it determines the output voltage swings because the following stages are basically in the emitter-follower configuration.

Constant current
source Q204

The ac load resistor for this stage is collector-emitter impedance of Q204.

Thermal
compensator
for dc bias
current
D201, D202

The negative temperature coefficient of D201 and D202 provide thermal compensation for the complementary and power transistor circuits. D202 is attached to the power transistor's heat sink to detect temperature increases in the power transistor.

Driver
Q205, Q206

These transistor operate as emitter-followers to provide the current swings demanded of the output stages and also provide the necessary phase inversion. Phase inversion is performed by using PNP and NPN type transistor.

Power transistor
Q207, Q208

The output transistors (Q207 and Q208) are connected directly to a power supply of about ± 23 V.

Q207 supplies power to the load during the positive half cycle and Q208 operates during the negative half cycle. As all the stages are directly coupled and designed to obtain zero potential at the output terminal, the large coupling capacitor at the output (which may cause power loss or distortion at low frequencies) is eliminated.

1-3. LEVEL DIAGRAM

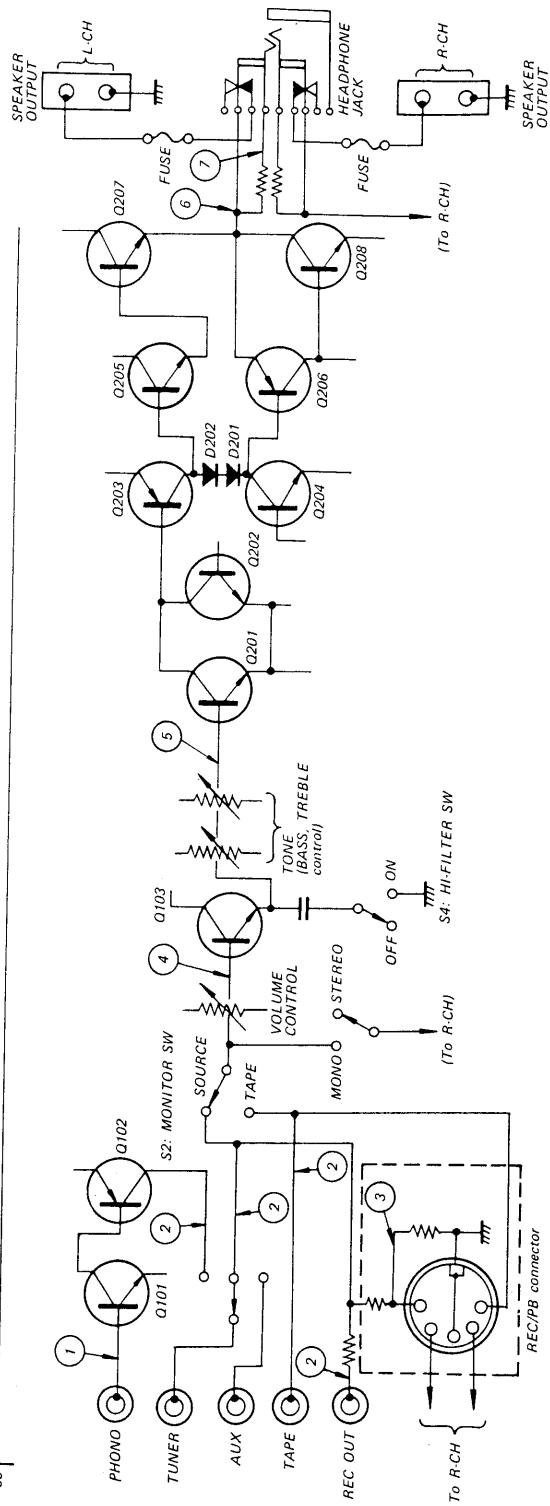
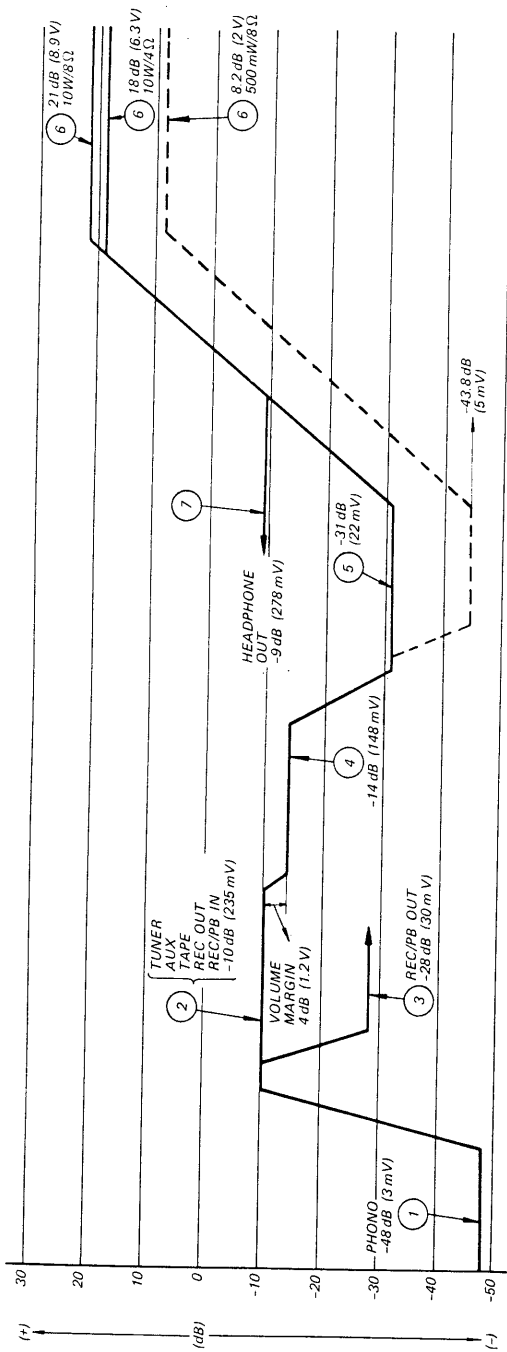

1-4. BLOCK DIAGRAM

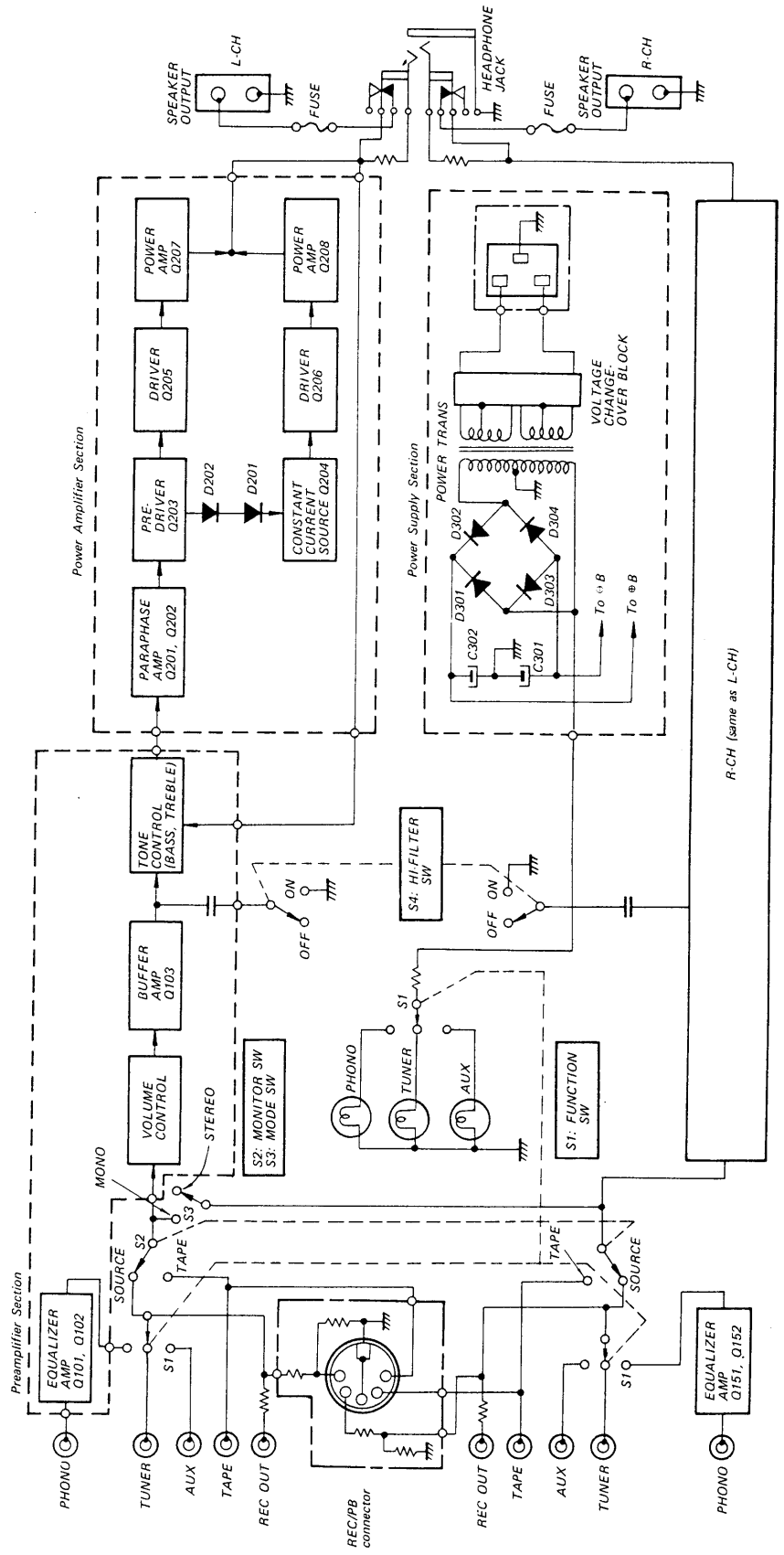

SECTION 2 DISASSEMBLY AND REPLACEMENT PROCEDURES

WARNING

Unplug the ac power cord before starting any disassembly or replacement procedures.

2-1. HARDWARE IDENTIFICATION GUIDE

The following chart will help you to decipher the hardware codes given in this service manual.

Note: All screws in this set are manufactured to the specifications of the International Organization for Standardization (ISO). This means that the new and old screws are not interchangeable because ISO screws have an identification mark on their heads as shown in Fig. 2-1.

All screws in this service manual are phillips type (cross recess type) unless otherwise indicated.
(-); slotted head

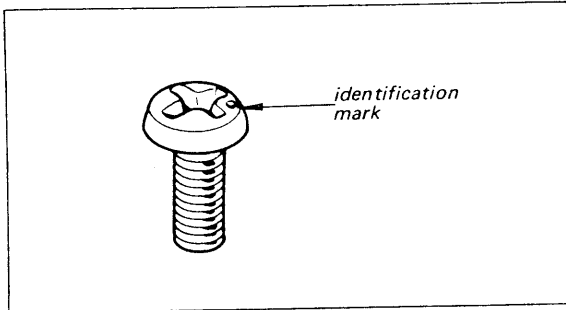

Fig. 2-1. ISO screw

- Hardware Nomenclature -

P	- Pan Head Screw	⊕	
PS	- Pan Head Screw with Spring Washer	⊕	
K	- Flat Countersunk Head Screw	⊕	
B	- Binding Head Screw	⊕	
RK	- Oval Countersunk Head Screw	⊕	
T	- Truss Head Screw	⊕	
R	- Round Head Screw	⊕	
F	- Flat Fillister Head Screw	⊕	
SC	- Set Screw	⊖	
E	- Retaining Ring (E Washer)	⊖	
	W	- Washer	
	SW	- Spring Washer	
	LW	- Lock Washer	
	N	- Nut	

- Example -

⊕ P 3x10

Type of Slot

Length in mm (L)

Diameter in mm (D)

Type of Head

2-2. WOODEN CASE REMOVAL

1. Remove the four screws securing the wooden case to the chassis with rubber foot.
2. Remove the four screws at the rear panel shown in Fig. 2-2.
3. Push the chassis out carefully and place it on a soft protective pad, otherwise the bottom of the front panel will be scratched.

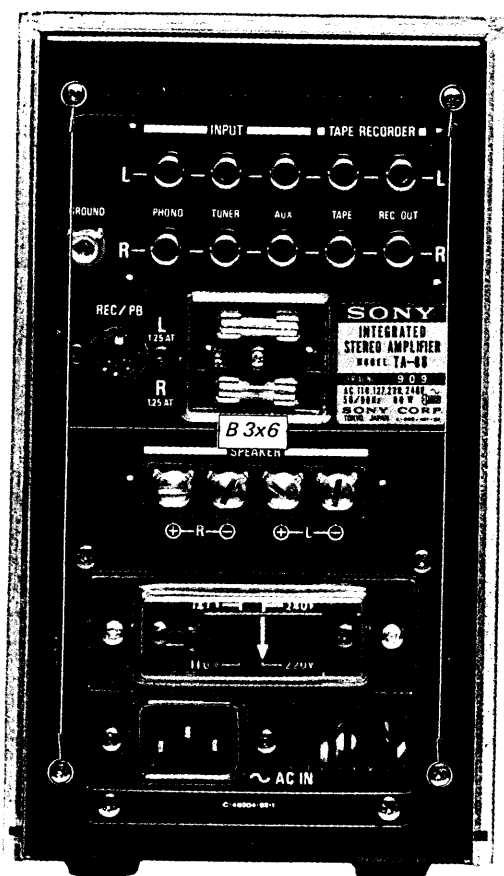

Fig. 2-2. Wooden case removal

2-3. FRONT PANEL REMOVAL

1. Remove the wooden case as described in Procedure 2-2.
2. Remove the FUNCTION switch and VOLUME, TONE control knobs by pulling them off.
3. Remove the four screws behind top and bottom edge of the front subchassis shown in Fig. 2-3.

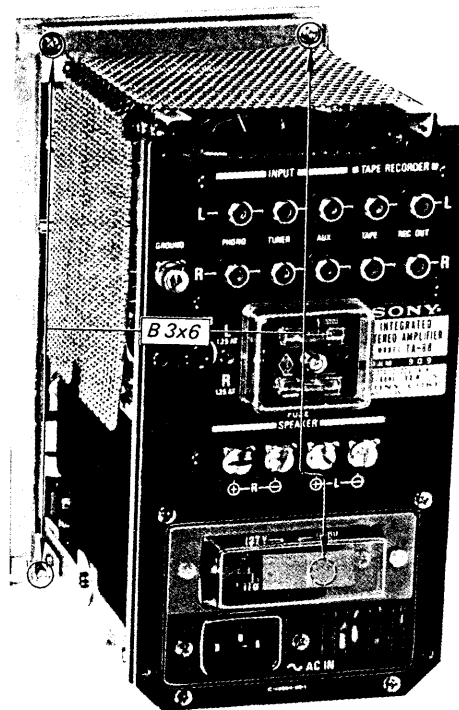

Fig. 2-3. Front panel removal

2-4. FRONT SUBCHASSIS REMOVAL

1. Remove the front panel as described in Procedure 2-3.
2. Remove the five screws shown in Fig. 2-4.

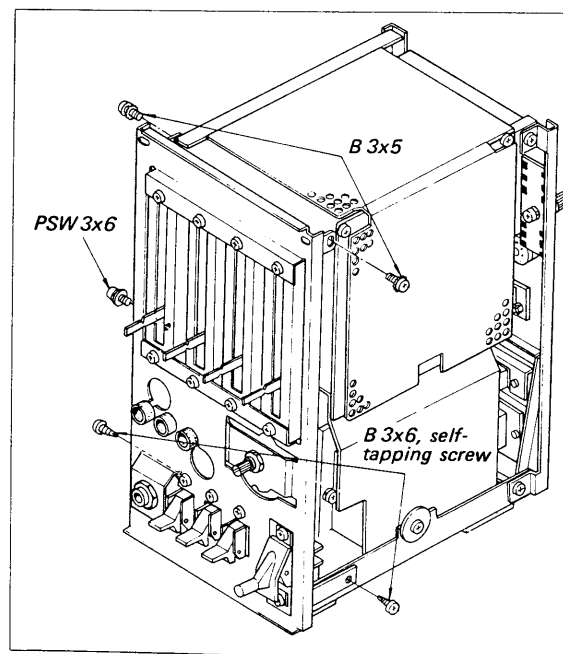

Fig. 2-4. Front subchassis removal

2-5. CONTROL AND SWITCH REPLACEMENT

1. Remove the front panel and front subchassis as described in Procedures 2-3 and 2-4.
2. Remove the screws and nuts securing the switches and controls to the front subchassis (See Fig. 2-5), and then install a new one.

2-6. POWER AMPLIFIER/POWER SUPPLY BOARD REMOVAL

1. Remove the wooden case as described in Procedure 2-2.
2. Loosen the two screws securing the pre-amplifier board to its bracket shown in Fig. 2-6.
3. Remove the shield plate. This permit the power transistor removal shown in Fig. 2-6.
4. Remove the four screws securing the power transistor to the heat sink shown in Fig. 2-7.
5. Remove the four screws shown in Fig. 2-8.
6. This frees power amplifier/power supply board.

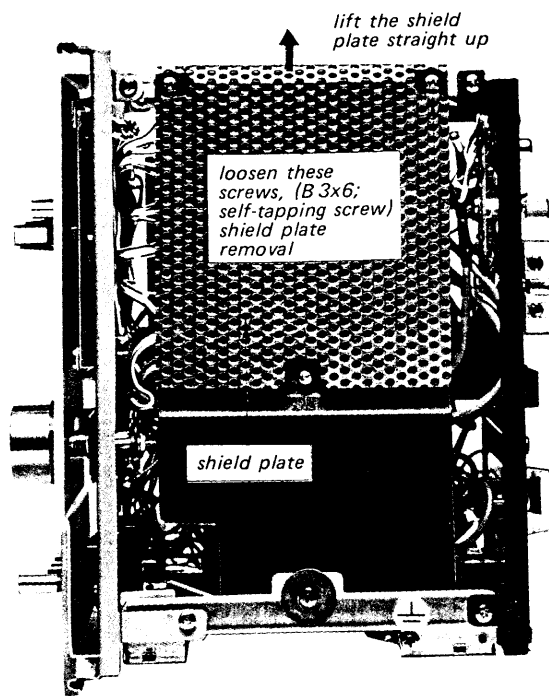

Fig. 2-6. Shield plate removal

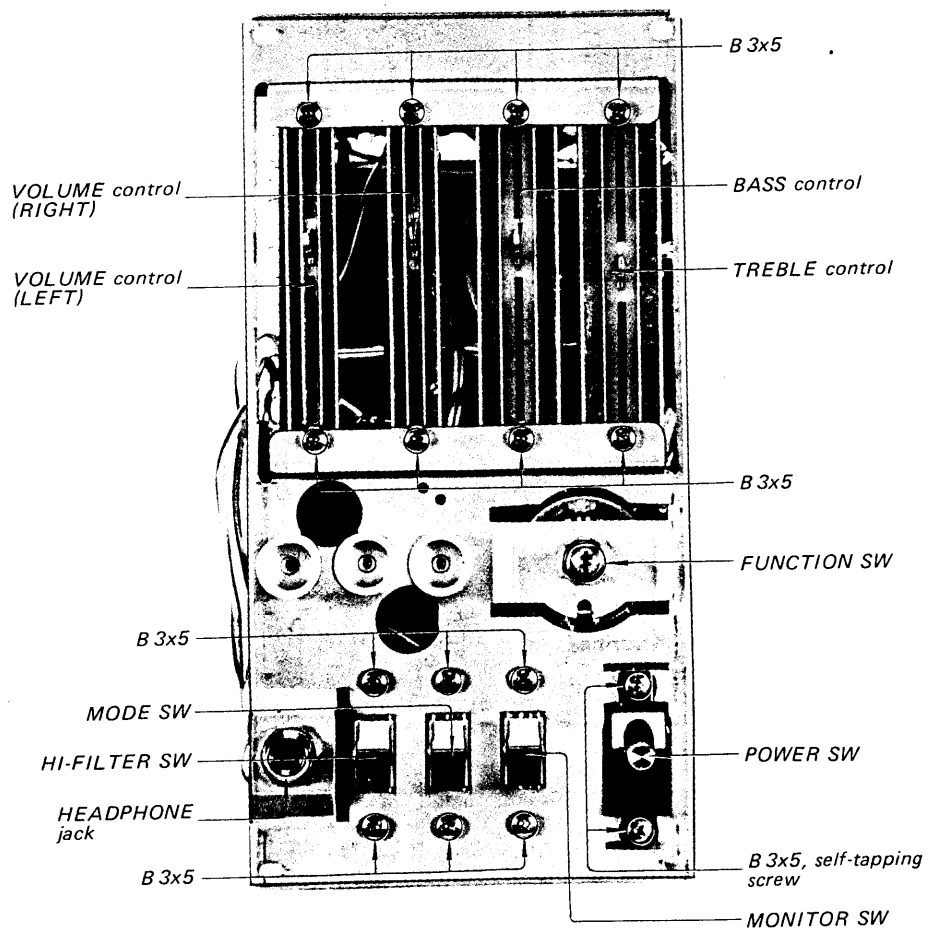

Fig. 2-5. Switch and control replacement

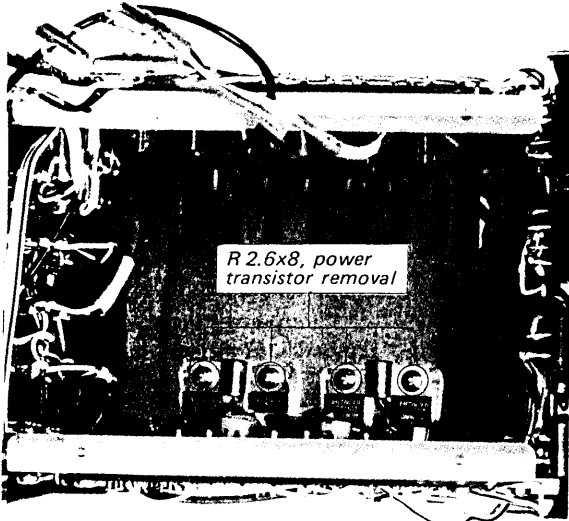

Fig. 2-7. Power transistor removal

- When replacing the power transistor, apply a coating of a heat-transferring grease to both sides of insulation mica spacer to the indicated portion as shown in Fig. 2-9. Any excess grease squeezed out when the mounting bolts are tightened should be wiped off with a clean cloth. This prevents it from accumulating conductive dust particles that might eventually cause a short.

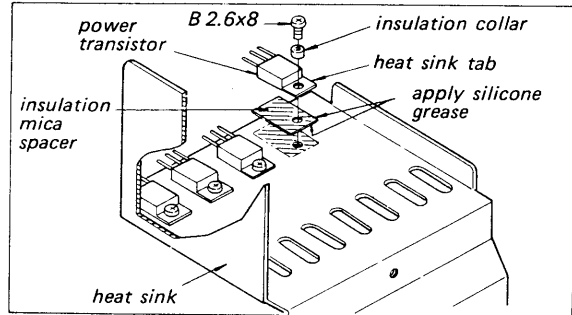

Fig. 2-9. Power transistor replacement

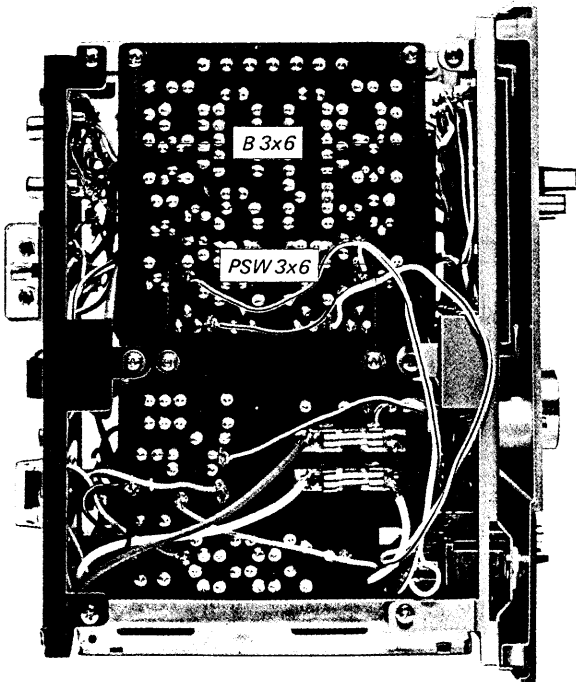

Fig. 2-8. Power amplifier/power supply board removal

2-8. REAR PANEL REMOVAL

- Remove the wooden case as described in Procedure 2-2.
- Remove the five screws shown in Fig. 2-10.

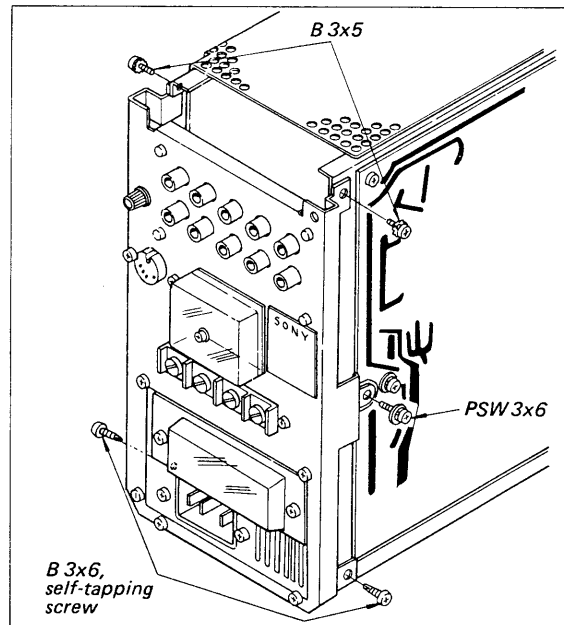

Fig. 2-10. Rear panel removal

2-7. POWER TRANSISTOR REPLACEMENT

- Remove the power amplifier/power supply board as described in Procedure 2-6.
- Unsolder the leads of power transistor, and then install a new one.

2-9. REPLACEMENT OF COMPONENTS SECURED TO THE REAR PANEL BY NYLON RIVETS

1. Remove the nylon rivets securing the defective component by pushing its end with a tweezers shown in Fig. 2-11.
2. Remove the defective component and then install a new one.
3. To reinstall the rivet, insert the flared part into the opening first, and then push the head as far as it will go, shown in Fig. 2-12.

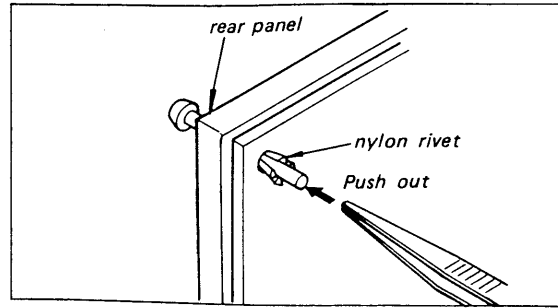

Fig. 2-11. Nylon rivet removal

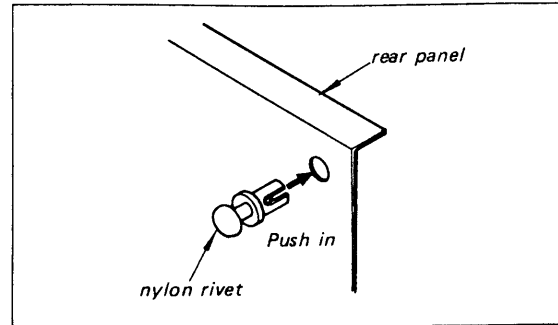
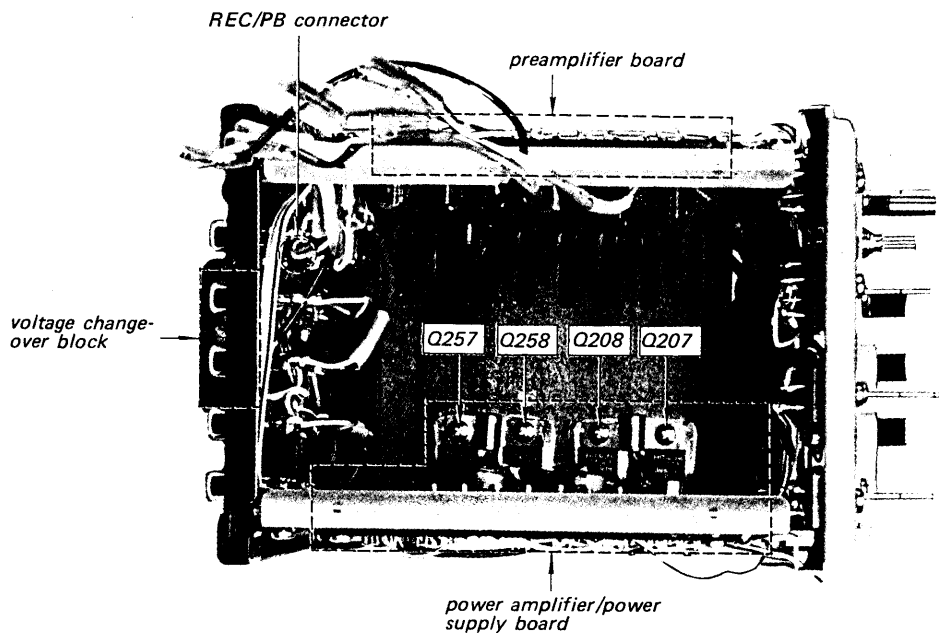

Fig. 2-12. Nylon rivet installation

2-10. CHASSIS LAYOUT



SECTION 3 REPACKING

The original shipping carton and packing materials are the ideal containers for shipping the unit. However to secure the maximum protection, the

set must be repacked in these materials precisely as before. The proper repacking procedures are shown in Fig. 3-1.

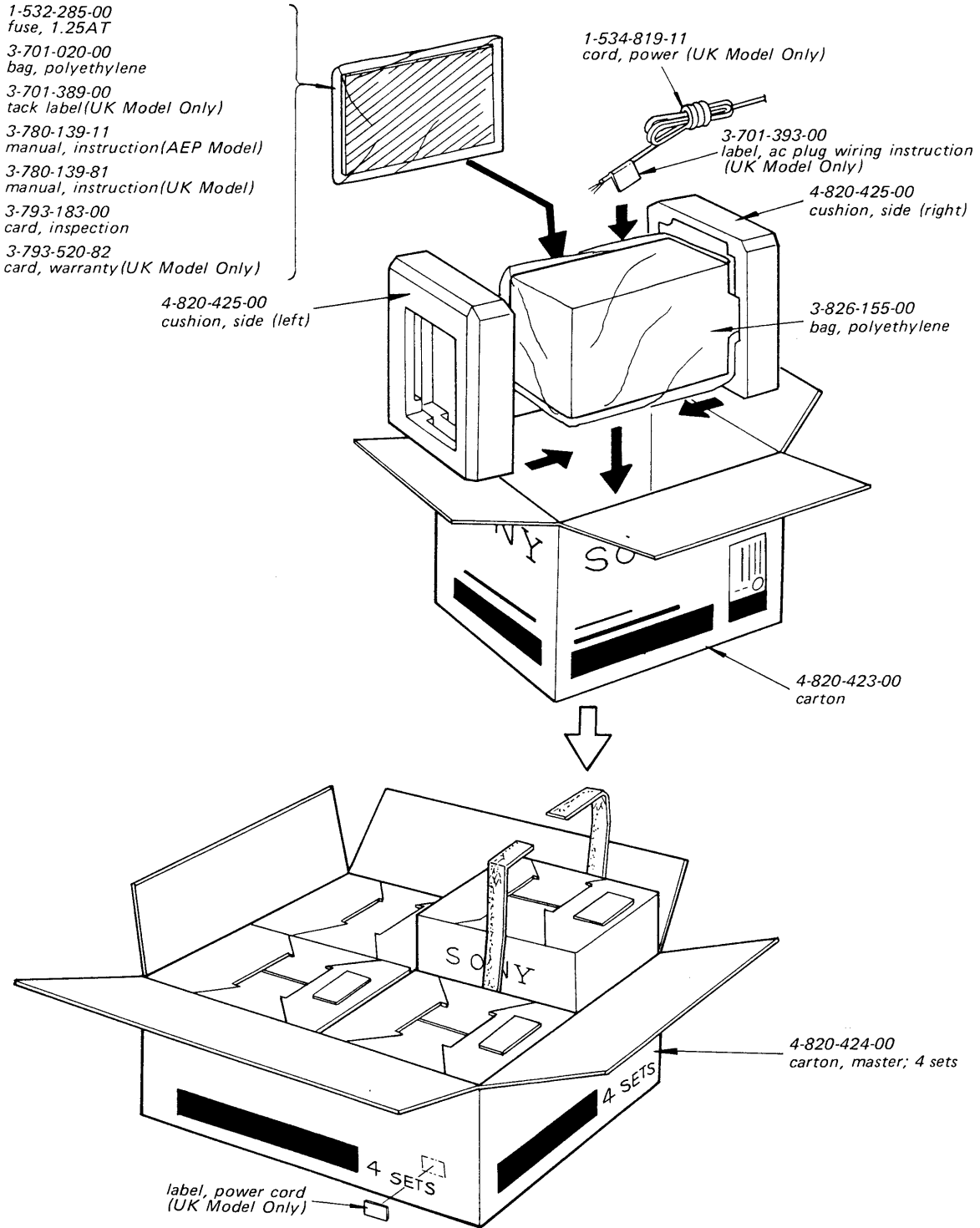
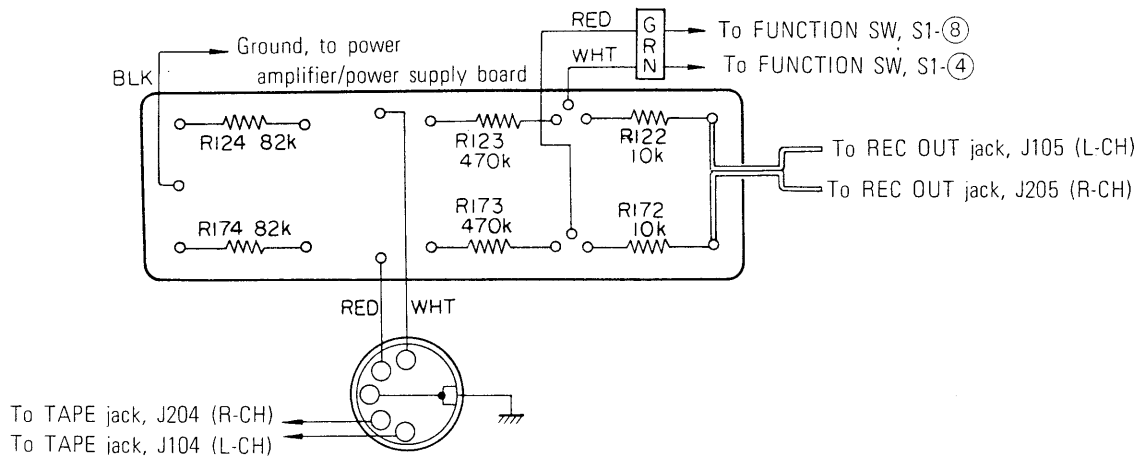

Fig. 3-1. Repacking

SECTION 4 DIAGRAMS

4-1. MOUNTING DIAGRAM — Attenuator Board —



4-2. MOUNTING DIAGRAM — Preamplifier Board —

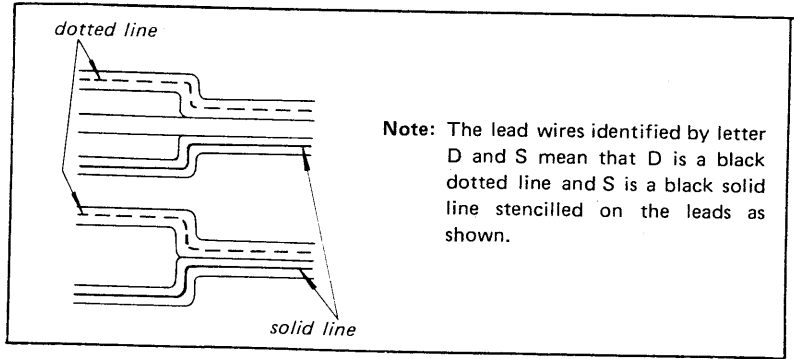
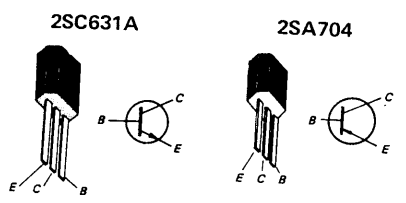
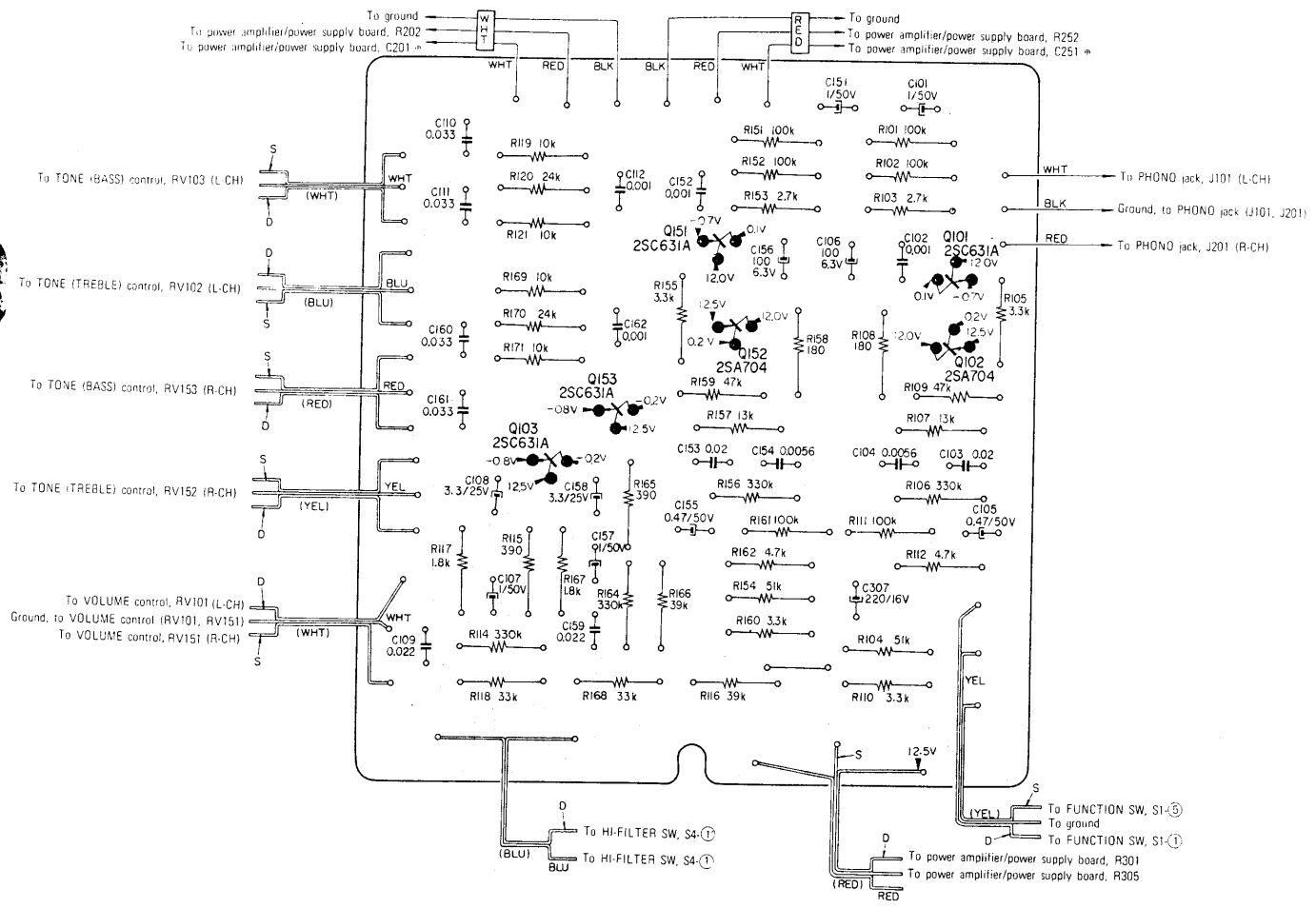

4-3. MOUNTING DIAGRAM — Power Amplifier/Power Supply Board —

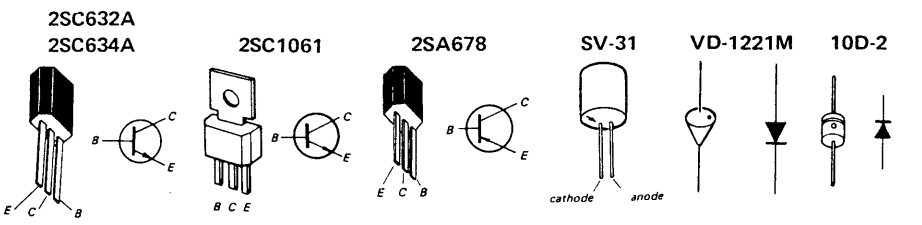
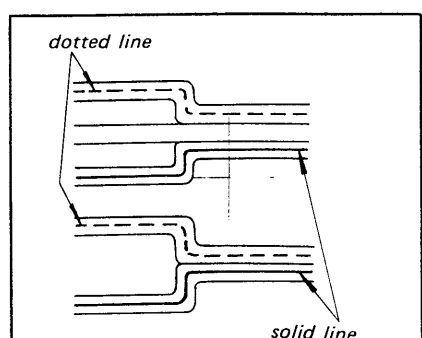
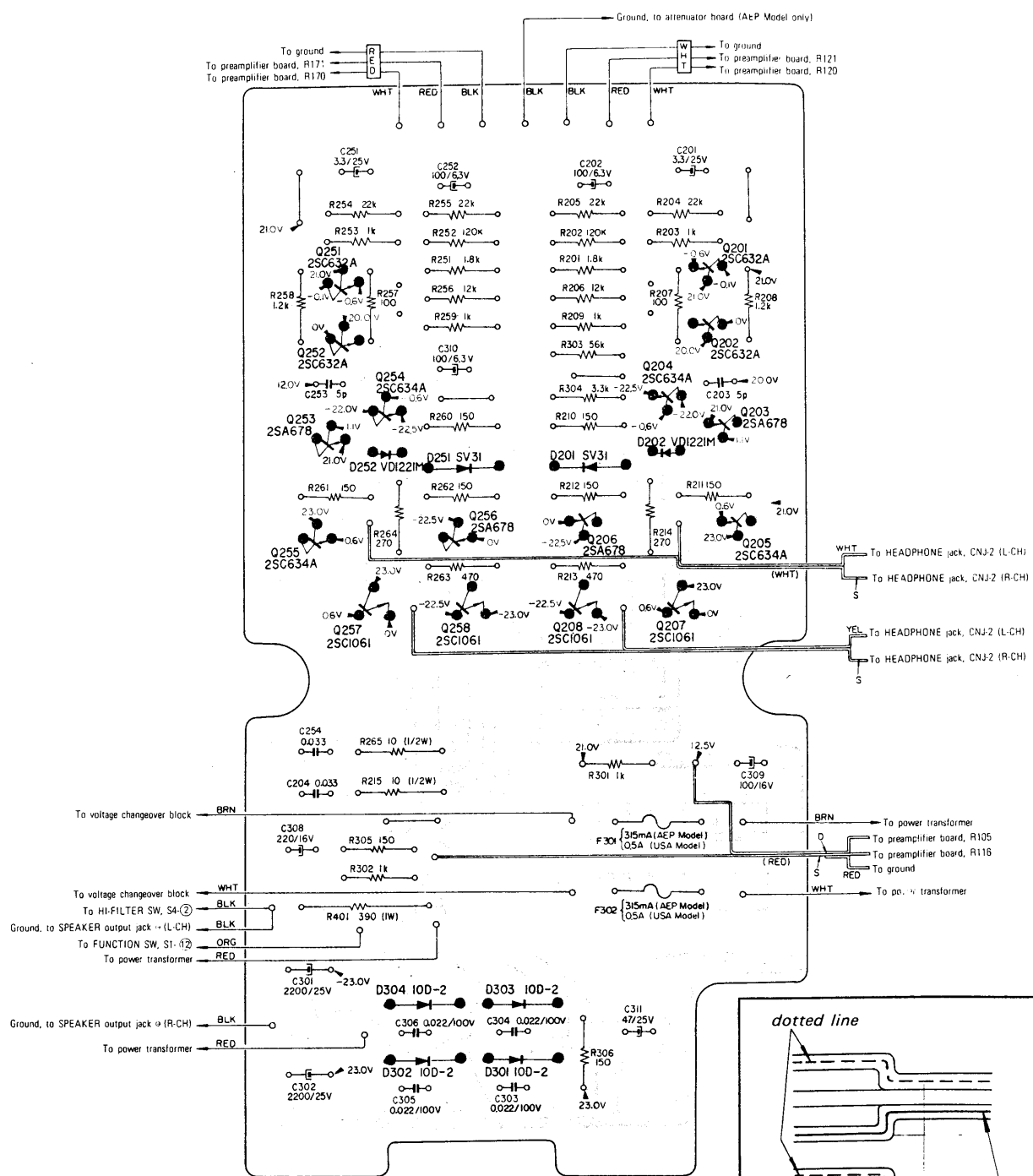

Note: The lead wires identified by letter D and S mean that D is a black dotted line and S is a black solid line stenciled on the leads as shown.

4-4. SCHEMATIC DIAGRAM

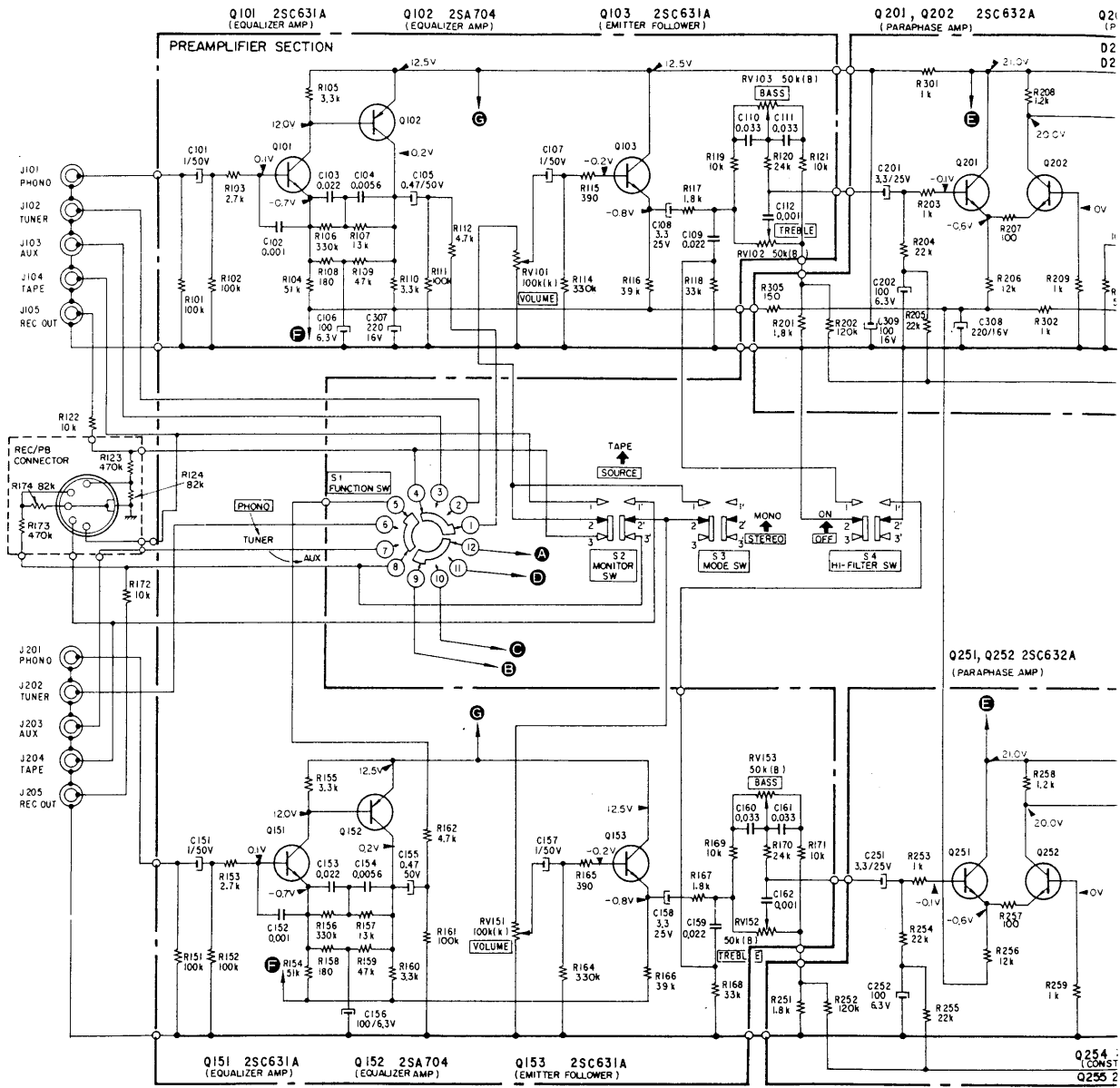

Ref. No.	Description	Position	Ref. No.	Description	Position
S1	FUNCTION SW (PHONO-TUNER-AUX)	PHONO	S4	HI-FILTER SW (ON-OFF)	OFF
S2	MONITOR SW (SOURCE-TAPE)	SOURCE	S5	POWER SW (ON-OFF)	OFF
S3	MODE SW (STEREO-MONO)	STEREO			

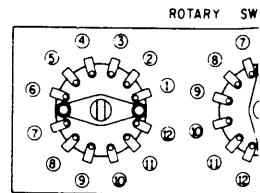

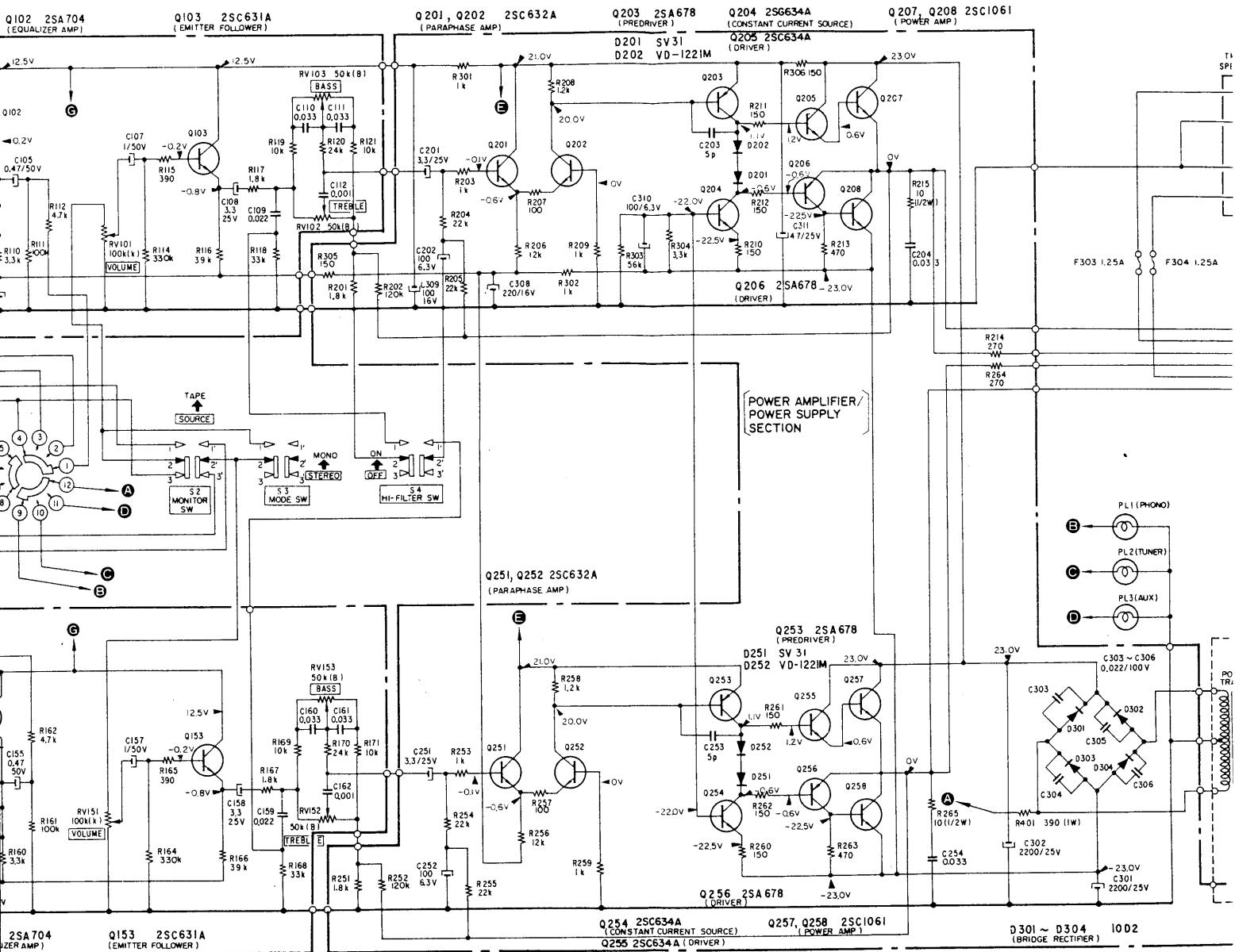

Ref. No.	Description	Position
S4	HI-FILTER SW (ON-OFF)	OFF
S5	POWER SW (ON-OFF)	OFF

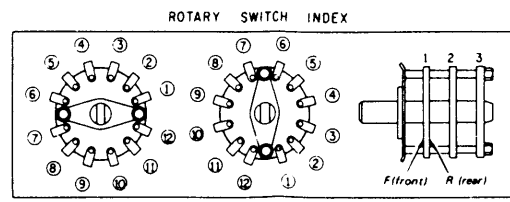

Note:
 All resistance values are in ohms. k = 1,000
 All capacitance values are in μ F except as ind
 which means μ F.
 All voltages represent an average value and
 within $\pm 20\%$.
 All voltages are dc measured with a VOM
 input impedance of 20 kohms/volt. No signa

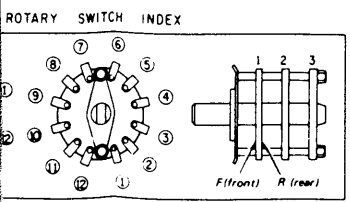
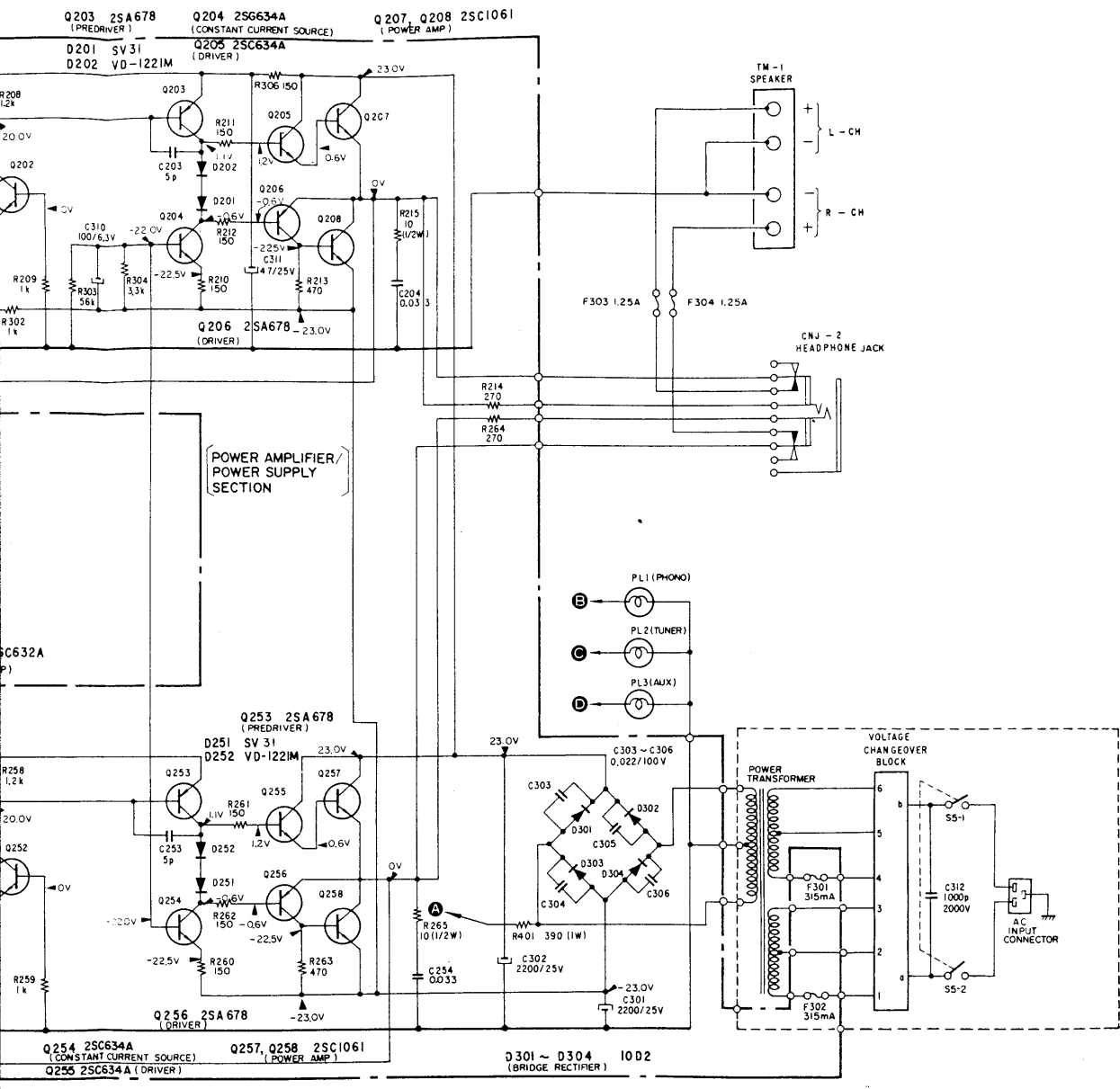

Note:
 All resistance values are in ohms, k = 1,000, M = 1,000 k
 All capacitance values are in μF except as indicated with p, which means μpF .
 All voltages represent an average value and should hold within $\pm 20\%$.
 All voltages are dc measured with a VOM which has an input impedance of 20 kohms/volt. No signal in.

SONY.
TA-88
 © 1972

SECTION 6
ELECTRICAL PARTS LIST

<u>Ref. No.</u>	<u>Part No.</u>	<u>Description</u>	<u>Ref. No.</u>	<u>Part No.</u>	<u>Description</u>
MOUNTED CIRCUIT BOARDS			C104 (C154)	1-105-510-12	0.0056 ±5% 50 V mylar
			C105 (C155)	1-121-911-00	0.47 ±10% 50 V electrolytic
8-982-675-21		mounted circuit board, preamplifier	C106 (C156)	1-121-413-00	100 ±50% 6.3 V electrolytic
8-982-675-22		mounted circuit board, power amplifier/ power supply	C107 (C157)	1-121-912-00	1 ±10% 50 V electrolytic
8-982-675-23		mounted circuit board, attenuator	C108 (C158)	1-121-913-00	3.3 ±10% 25 V electrolytic
			C109 (C159)	1-105-517-12	0.022 ±5% 50 V mylar
			C110 (C160)	1-105-519-12	0.033 ±5% 50 V mylar
			C111 (C161)	1-105-519-12	0.033 ±5% 50 V mylar
			C112 (C162)	1-105-501-12	0.001 ±5% 50 V mylar
SEMICONDUCTORS			C201 (C251)	1-121-392-00	3.3 ±75% 25 V electrolytic
D201 (D251)		diode SV-31	C202 (C252)	1-121-413-00	100 ±50% 6.3 V electrolytic
D202 (D252)		diode VD-1221M	C203 (C253)	1-101-955-00	5 p ±5% 50 V ceramic
			C204 (C254)	1-105-679-12	0.033 ±10% 50 V mylar
D301		diode 10D-2	C301	1-123-047-00	2,200 ±100% 25 V electrolytic
D302		diode 10D-2	C302	1-123-047-00	2,200 ±100% 25 V electrolytic
D303		diode 10D-2	C303	1-105-877-12	0.022 ±20% 100 V mylar
D304		diode 10D-2	C304	1-105-877-12	0.022 ±20% 100 V mylar
Q101 (Q151)		transistor 2SC631A	C305	1-105-877-12	0.022 ±20% 100 V mylar
Q102 (Q152)		transistor 2SA704	C306	1-105-877-12	0.022 ±20% 100 V mylar
Q103 (Q153)		transistor 2SC631A	C307	1-121-421-00	220 ±50% 16 V electrolytic
Q201 (Q251)		transistor 2SC632A	C308	1-121-421-00	220 ±50% 16 V electrolytic
Q202 (Q252)		transistor 2SC632A	C309	1-121-415-00	100 ±50% 16 V electrolytic
Q203 (Q253)		transistor 2SA678	C310	1-121-413-00	100 ±50% 6.3 V electrolytic
Q204 (Q254)		transistor 2SC634A	C311	1-121-410-00	47 ±50% 25 V electrolytic
Q205 (Q255)		transistor 2SC634A	C312	1-102-222-00	1,000 p ±20% 250 V ceramic
Q206 (Q256)		transistor 2SA678			
Q207 (Q257)		transistor 2SC1061			
Q208 (Q258)		transistor 2SC1061			
TRANSFORMERS			RESISTORS		
PT	1-441-931-00	transformer, power	All resistance values are in Ω, ±5%, ¼W and carbon type unless otherwise indicated.		
CAPACITORS			R101 (R151)	1-244-721-00	100 k
All capacitance values are in μF except as indicated with p, which means μμF.			R102 (R152)	1-244-721-00	100 k
C101 (C151)	1-121-912-00	1 ±10% 50 V electrolytic	R103 (R153)	1-244-683-00	2.7 k
C102 (C152)	1-105-661-12	0.001 ±10% 50 V mylar	R104 (R154)	1-244-714-00	51 k
C103 (C153)	1-106-032-12	0.02 ±5% 50 V mylar	R105 (R155)	1-244-685-00	3.3 k
			R106 (R156)	1-244-733-00	330 k
			R107 (R157)	1-244-700-00	13 k
			R108 (R158)	1-244-655-00	180
			R109 (R159)	1-244-713-00	47 k
			R110 (R160)	1-244-685-00	3.3 k
			R111 (R161)	1-244-721-00	100 k
			R112 (R162)	1-244-689-00	4.7 k
			R113	-----	
			R114 (R164)	1-244-733-00	330 k
			R115 (R165)	1-244-663-00	390

<u>Ref. No.</u>	<u>Part No.</u>	<u>Description</u>
R116 (R166)	1-244-711-00	39 k
R117 (R167)	1-244-679-00	1.8 k
R118 (R168)	1-244-709-00	33 k
R119 (R169)	1-244-697-00	10 k
R120 (R170)	1-244-706-00	24 k
R121 (R171)	1-244-697-00	10 k
R122 (R172)	1-202-043-00	10 k ±5% 1/8W composition
R123 (R173)	1-202-145-00	470 k ±5% 1/8W composition
R124 (R174)	1-202-095-00	82 k ±5% 1/8W composition
R201 (R251)	1-244-679-00	1.8 k
R202 (R252)	1-244-723-00	120 k
R203 (R253)	1-244-673-00	1 k
R204 (R254)	1-244-705-00	22 k
R205 (R255)	1-244-705-00	22 k
R206 (R256)	1-244-699-00	12 k
R207 (R257)	1-244-649-00	100
R208 (R258)	1-244-675-00	1.2 k
R209 (R259)	1-244-673-00	1 k
R210 (R260)	1-244-653-00	150
R211 (R261)	1-244-653-00	150
R212 (R262)	1-244-653-00	150
R213 (R263)	1-244-665-00	470
R214 (R264)	1-244-659-00	270
R215 (R265)	1-202-525-00	10 ±20% 1/2W composition
R301	1-244-673-00	1 k
R302	1-244-673-00	1 k
R303	1-244-715-00	56 k
R304	1-244-685-00	3.3 k
R305	1-244-653-00	150
R306	1-244-653-00	150
R401	1-206-654-00	390 ±10% 2W metal-oxide

<u>Ref. No.</u>	<u>Part No.</u>	<u>Description</u>
RV101	1-224-052-00	100 kΩ (K), variable (VOLUME control)
RV102	1-224-051-00	50 kΩ (B)/50 kΩ (B), variable (TREBLE control)
RV103	1-224-051-00	50 kΩ (B)/50 kΩ (B), variable (BASS control)

SWITCHES

S1	1-516-124-00	switch, rotary (FUNCTION)
S2	1-514-509-00	switch, lever/slide (MONITOR)
S3	1-514-509-00	switch, lever/slide (MODE)
S4	1-514-509-00	switch, lever/slide (HI-FILTER)
S5	1-514-817-00	switch, lever/seesaw (POWER)

MISCELLANEOUS

CNJ1	1-509-359-00	REC/PB connector
CNJ2	1-507-355-00	jack, HEADPHONE
	1-507-445-00	AC input connector, 3-P
F301, 302	1-532-235-00	fuse, 315 mA
F303, 304	1-532-285-00	fuse, 1.25 AT
J101 ~ 105 } (J201 ~ 205)}	1-507-313-00	phono jack, 10-P
PL1	1-518-129-00	lamp, PHONO indicator 4.5 V/40 mA
PL2	1-518-129-00	lamp, TUNER indicator 4.5 V/40 mA
PL3	1-518-129-00	lamp AUX indicator 4.5 V/40 mA
TM1	1-536-405-00	terminal strip, 4-P; SPEAKER
VS	1-509-385-00	voltage changeover block
	1-534-819-11	cord, power (UK Model only)
	1-536-353-00	connection, terminal post
	1-536-354-00	terminal post
	1-581-944-00	jumper board, 10-P phono jack

SONY CORPORATION

© 1972

SERVICE MANUAL SUPPLEMENT

No. 1
Dec. 1972

Subject: Circuit Modification

This supplement updates the service manual to include production changes starting with Serial Number 901,001 (AEP Model), 401,001 (UK Model) and later. File this supplement with the service manual.

1. INTRODUCTION

Some modifications have been performed in Power Amplifier Section.

2. PARTS CHANGED

Ref. No.	Former	New	Applicable Serial No.
R210 (R260) R211 (R261) R212 (R262) R305, R306	1-244-653-11 150 ±5% ¼W carbon	1-244-649-00 100 ±5% ¼W carbon	AEP Model ... (Serial No. 901,001 and later) UK Model (Serial No. 401,001 and later)
F301 F302	1-532-235-11 fuse, 315 mAT	1-532-273-11 fuse, 250 mAT	

3. PARTS ADDED

Ref. No.	Part No.	Description	Applicable Serial No.
C205 (C255)	1-102-940-11	3P ±5% 50V ceramic	AEP Model ... (Serial No. 901,001 and later) UK Model (Serial No. 401,001 and later)

Note: Though two kinds of circuit boards exist for Power Amplifier board, listed part number is for only the latest one since it is interchangeable with old one.

4. MOUNTING DIAGRAM – Power Amplifier Board –

AEP Model Serial No. 901,001 and later
 UK Model Serial No. 401,001 and later

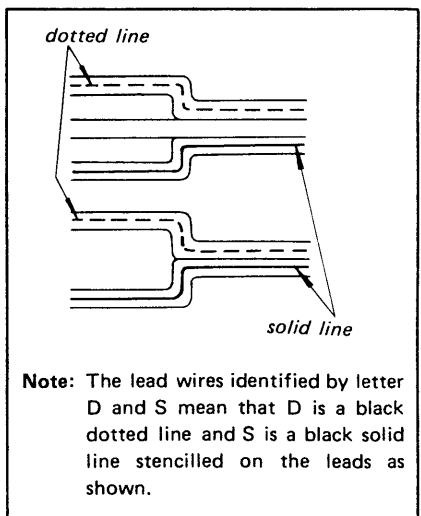
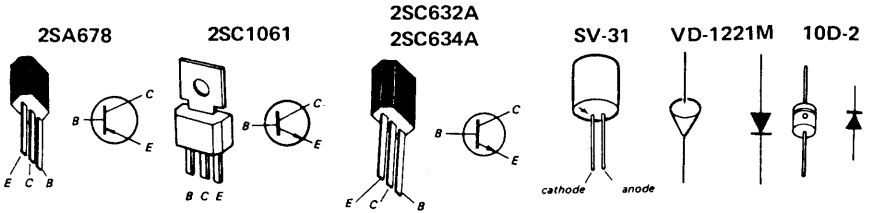
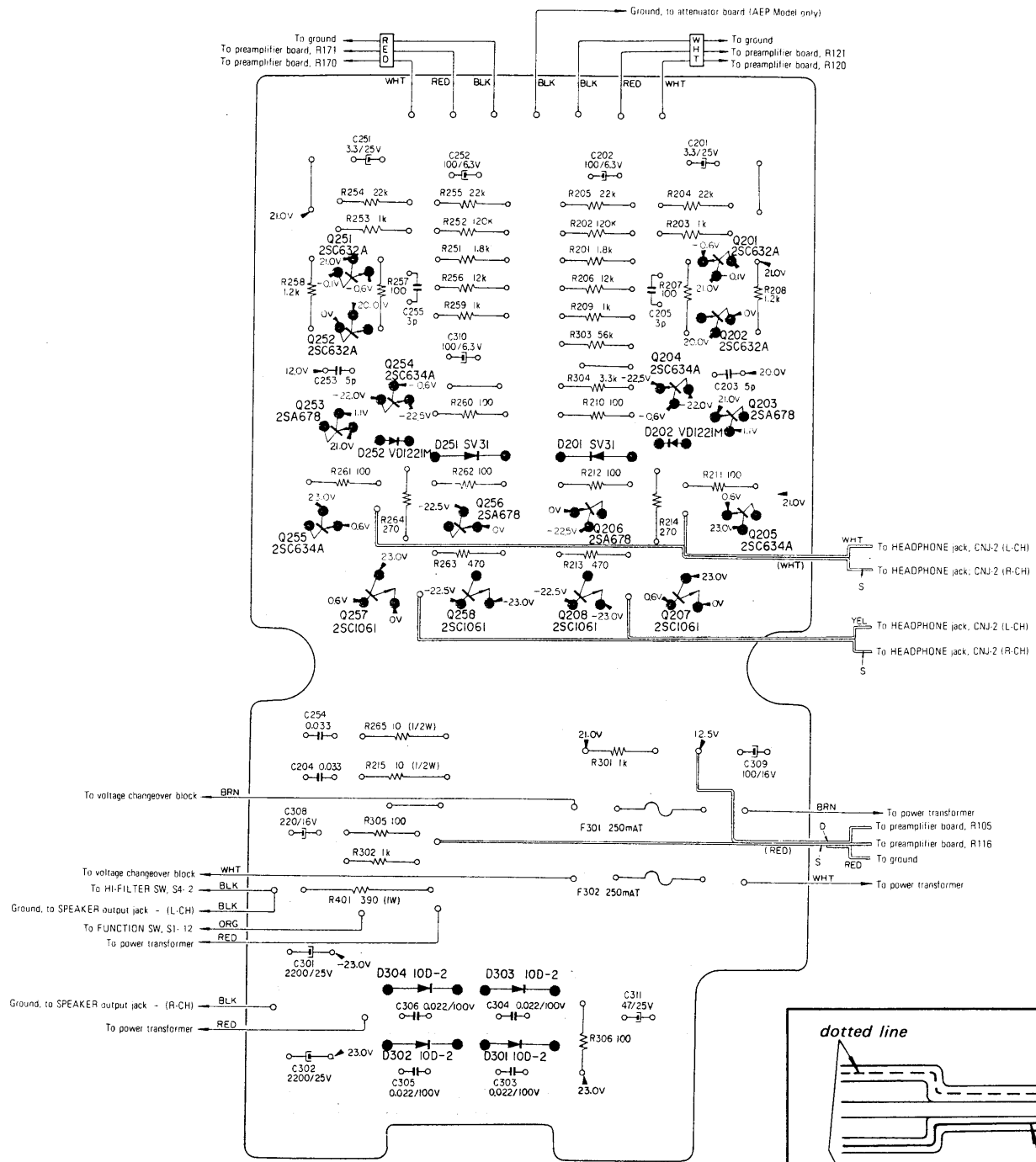

5. SCHEMATIC DIAGRAM

AEP Model..... Serial No. 901,001 and later
 UK Model Serial No. 401,001 and later

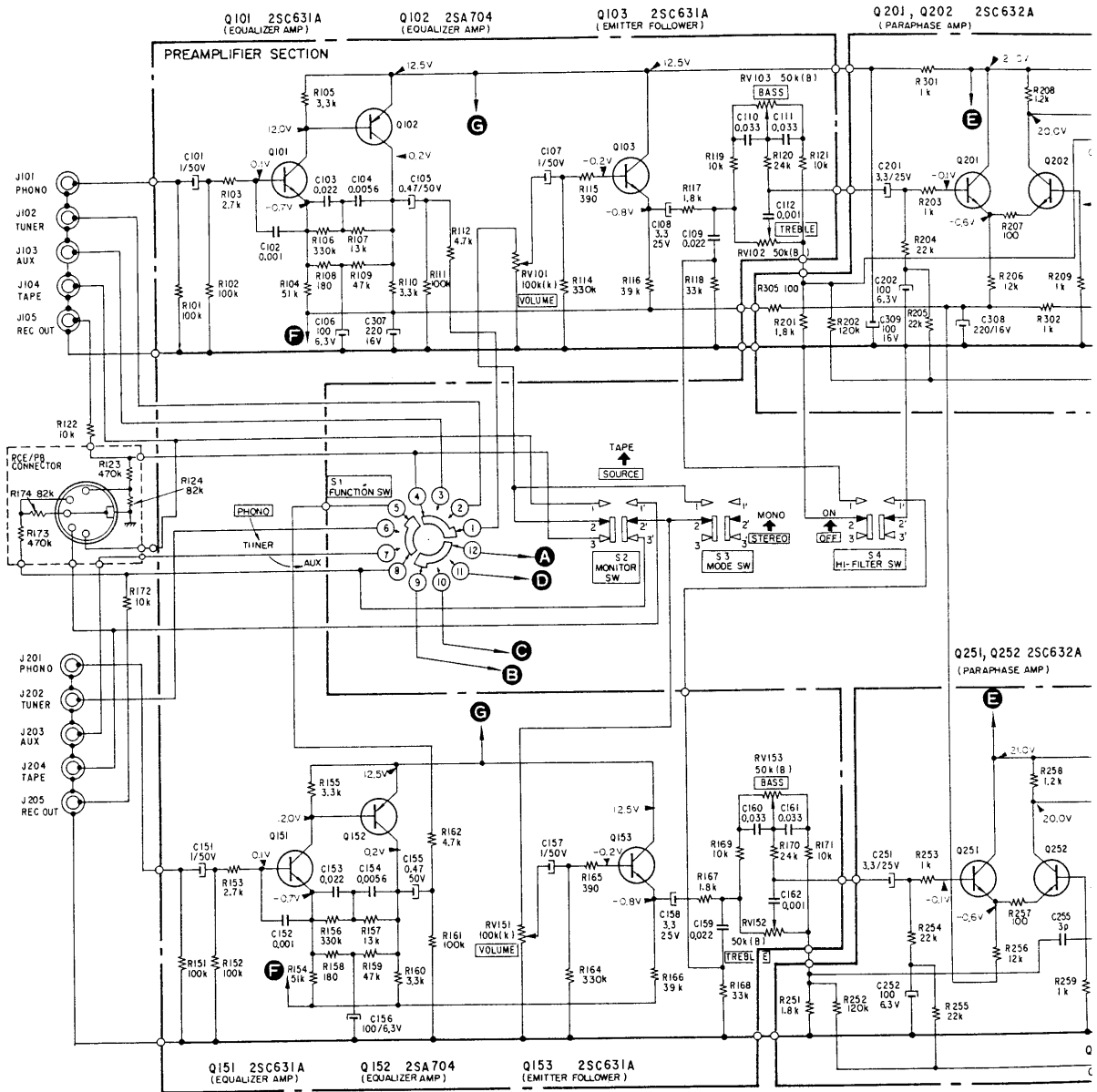

Ref. No.	Description	Position	Ref. No.	Description	Position
S1	FUNCTION SW (PHONO-TUNER-AUX)	PHONO	S4	HI-FILTER SW (ON-OFF)	OFF
S2	MONITOR SW (SOURCE-TAPE)	SOURCE	S5	POWER SW (ON-OFF)	OFF
S3	MODE SW (STEREO-MONO)	STEREO			

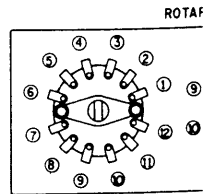

ater
ater

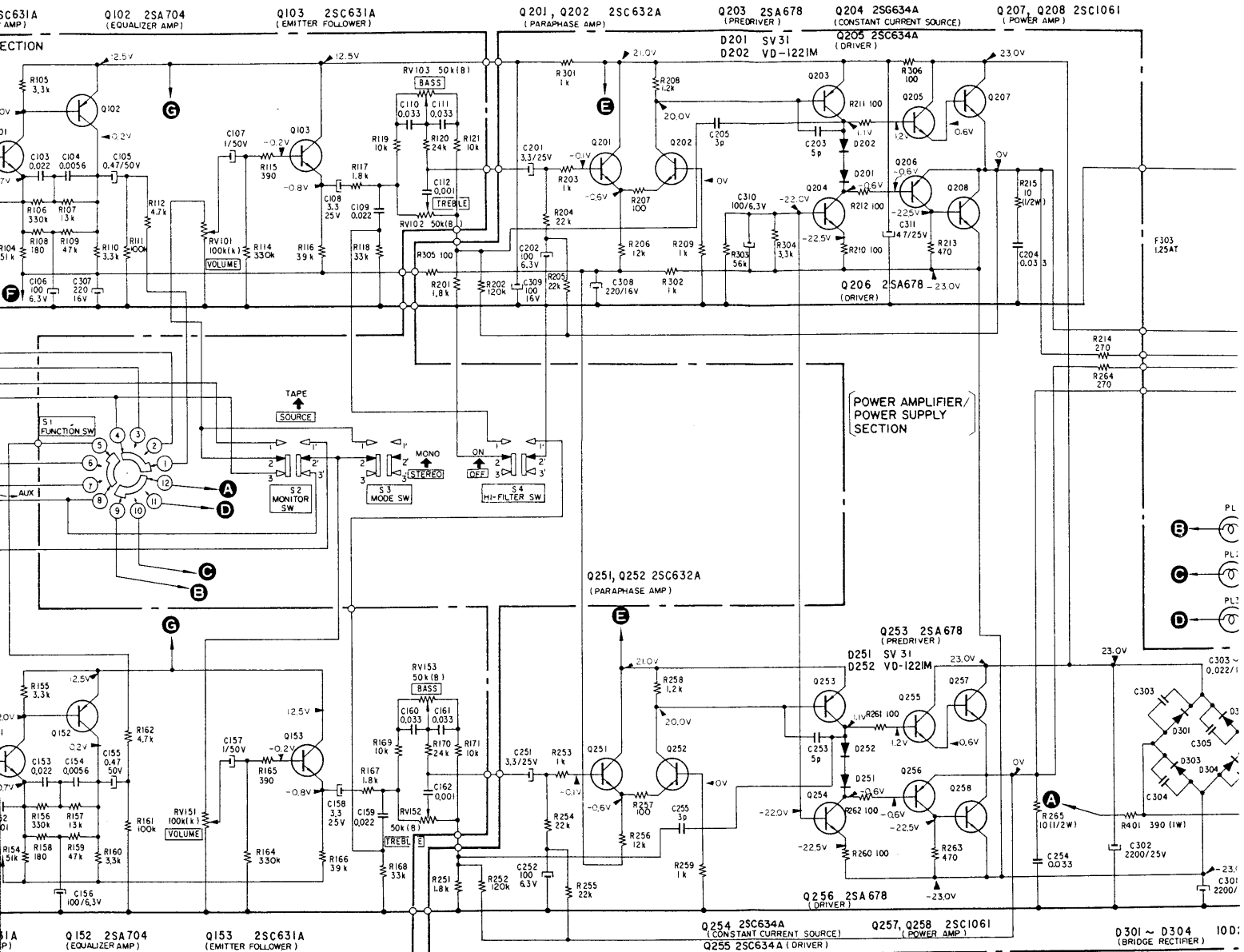

Position
MONO
SOURCE
STEREO

Ref. No.	Description	Position
S4	HI-FILTER SW (ON-OFF)	OFF
S5	POWER SW (ON-OFF)	OFF

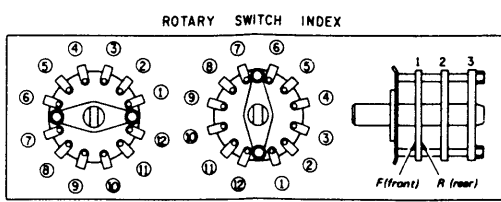

Note:
All resistance values are in ohms
All capacitance values are in μF
which means μF .
All voltages represent an average
within $\pm 20\%$.
All voltages are dc measured
input impedance of 20 kohms/

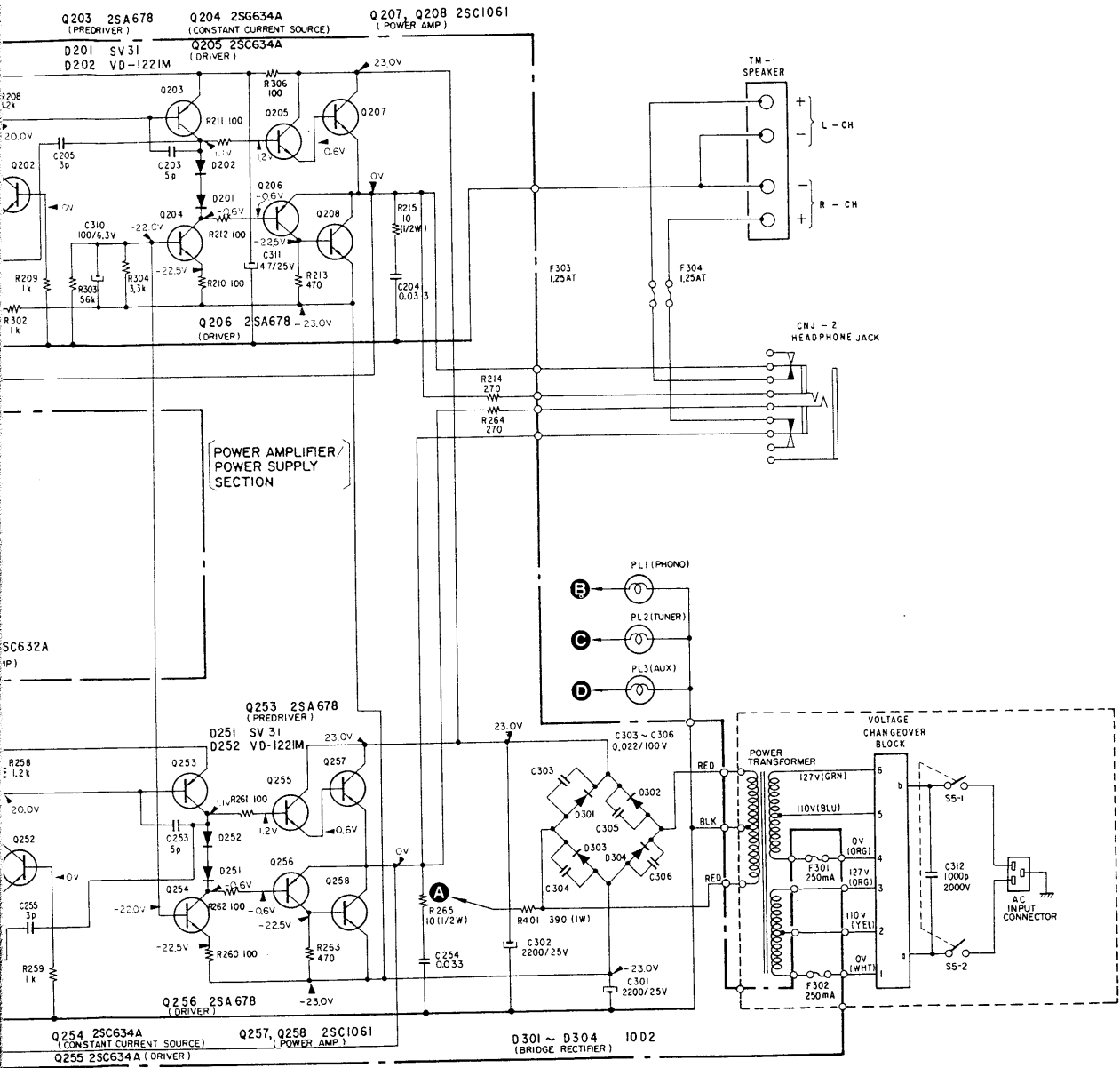

POWER AMPLIFIER/
POWER SUPPLY
SECTION

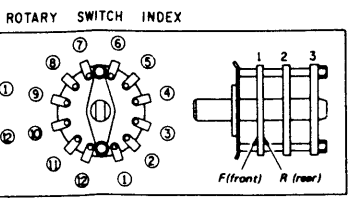
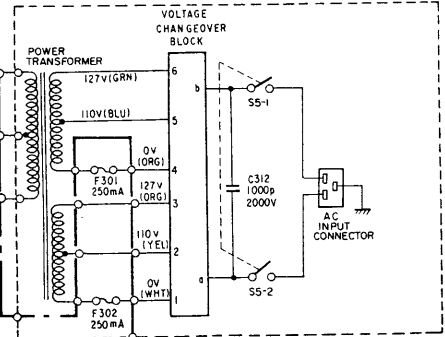

Note:
All resistance values are in ohms. k = 1,000, M = 1,000 k
All capacitance values are in μF except as indicated with p, which means μF .
All voltages represent an average value and should hold within $\pm 20\%$.
All voltages are dc measured with a VOM which has an input impedance of 20 kohms/volt. No signal in.

SONY
TA-88
© 1972