

SERVICE MANUAL

INTEGRATED STEREO AMPLIFIER

SANSUI AU-919

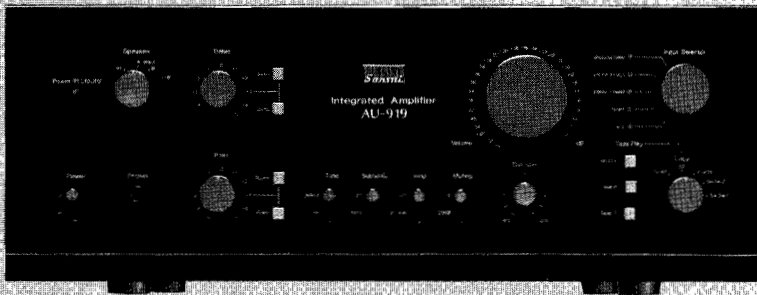

SPECIFICATIONS

- Power output**
 Min. RMS, both channels driven, from 10 to 20,000 Hz, with no more than 0.008 % total harmonic distortion
 100 watts per channel into 8 ohms
Load impedance 8 ohms
Total harmonic distortion (POWER AMP IN)
 less than 0.008 % at or below rated min. RMS power output
- Intermodulation distortion (70 Hz : 7 kHz = 4:1 SMPTE method)**
 less than 0.008 % at or below rated min. RMS power output
- Rise time** 0.5 μ sec
Slew rate 200 V/ μ sec
Frequency response (at 1 watt) (POWER AMP IN)
 DC to 500,000 Hz +0 dB -3 dB
- Damping factor (1 kHz, both channels driven)**
 100 into 8 ohms
- RIAA curve deviation (PHONO, 20 Hz to 20 kHz)**
 +0.2 dB, -0.2 dB
- Input sensitivity and impedance (1 kHz, for rated power output)**
PHONO-1 (MC) 0.1 mV/10 ohms
 (Max. input capability; 30 mV at 1 kHz, less than 0.03 % total harmonic distortion)
PHONO-1, 2 (MM) 2.5 mV/47 kilohms
 (Max. input capability; 350 mV at 1 kHz, less than 0.01 % total harmonic distortion)
- AUX, TUNER, TAPE PLAY**
 150 mV/47 kilohms
- POWER AMP IN** 1 V/47 kilohms
- Output level and impedance (1,000 Hz)**
TAPE REC (pin jack) 150 mV into 47 kilohms/
 600 ohms
PREAMP OUT 1 V into 47 kilohms/
 1.5 kilohms
- Channel separation (1 kHz, at rated power output)**
PHONO-1 (MC) 70 dB
PHONO-1, 2 (MM) 75 dB
- AUX, TUNER, TAPE PLAY**
 80 dB
- Hum and noise (short-circuit, A-network)**
PHONO-1 (MC) 74 dB
PHONO-1, 2 (MM) 90 dB
AUX, TUNER, TAPE PLAY
 100 dB
- Controls**
BASS \pm 6 dB (50 Hz)
 Tone selector 150 Hz, 300 Hz
TREBLE \pm 6 dB (15 kHz)
 Tone selector 3 kHz, 6 kHz
SUBSONIC -3 dB (16 Hz), 6 dB/oct
MUTING -20 dB
- Power requirements**
Power voltage 100, 120, 220, 240V (50/60 Hz)
Power consumption
 Rated consumption 480 watts
- Dimensions** 430 mm (16-15/16") W
 168 mm (6-5/8") H
 428 mm (16-7/8") D
- Weight** 21.4 kg (47.2 lbs) net
 23.8 kg (52.5 lbs) packed

* Design and specifications subject to changes without notice for improvements.



SANSUI ELECTRIC CO., LTD.

1. BLOCK DIAGRAM

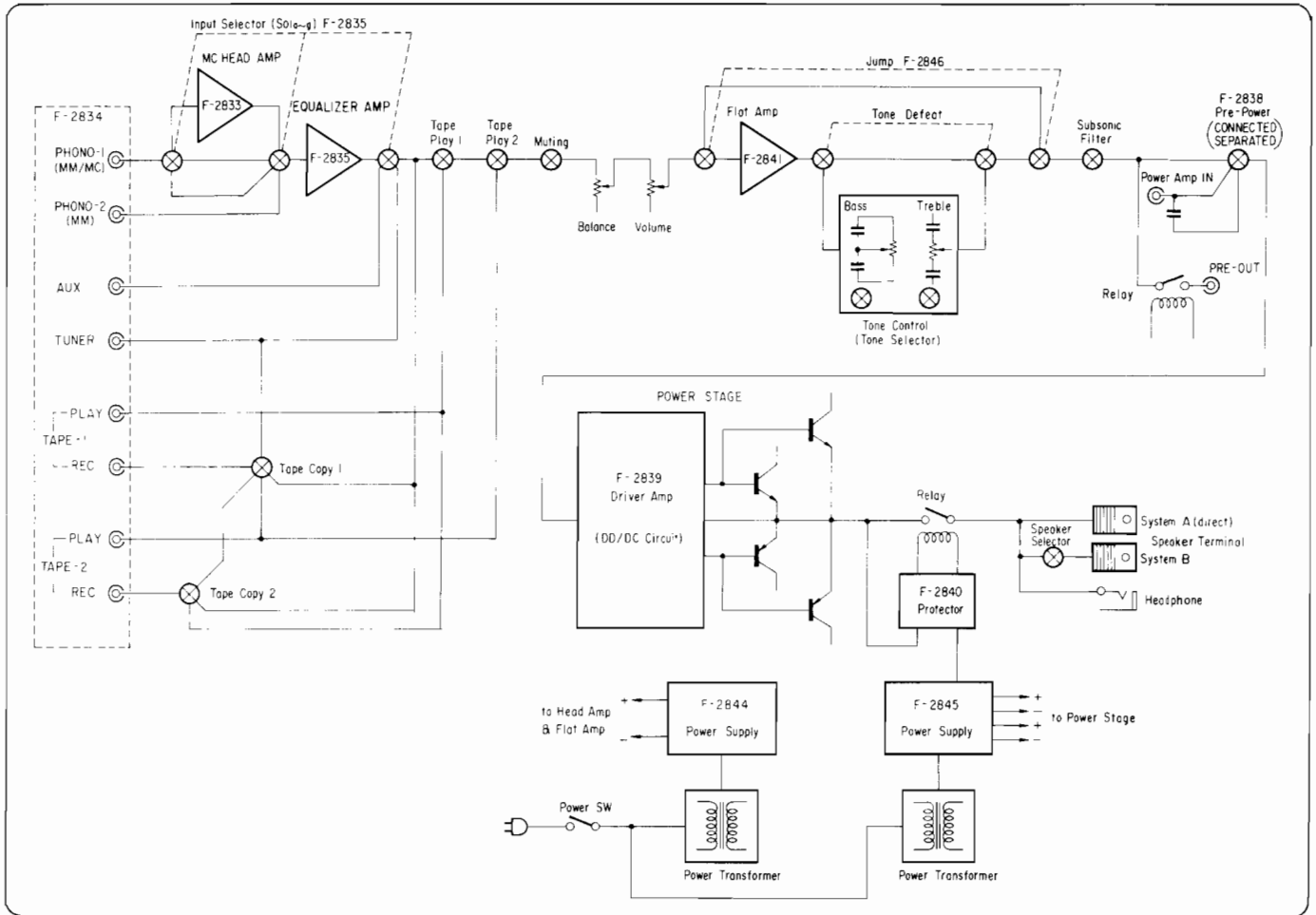

2. CIRCUIT DESCRIPTION

2-1. MC Head Amp and Phono Equalization Circuit

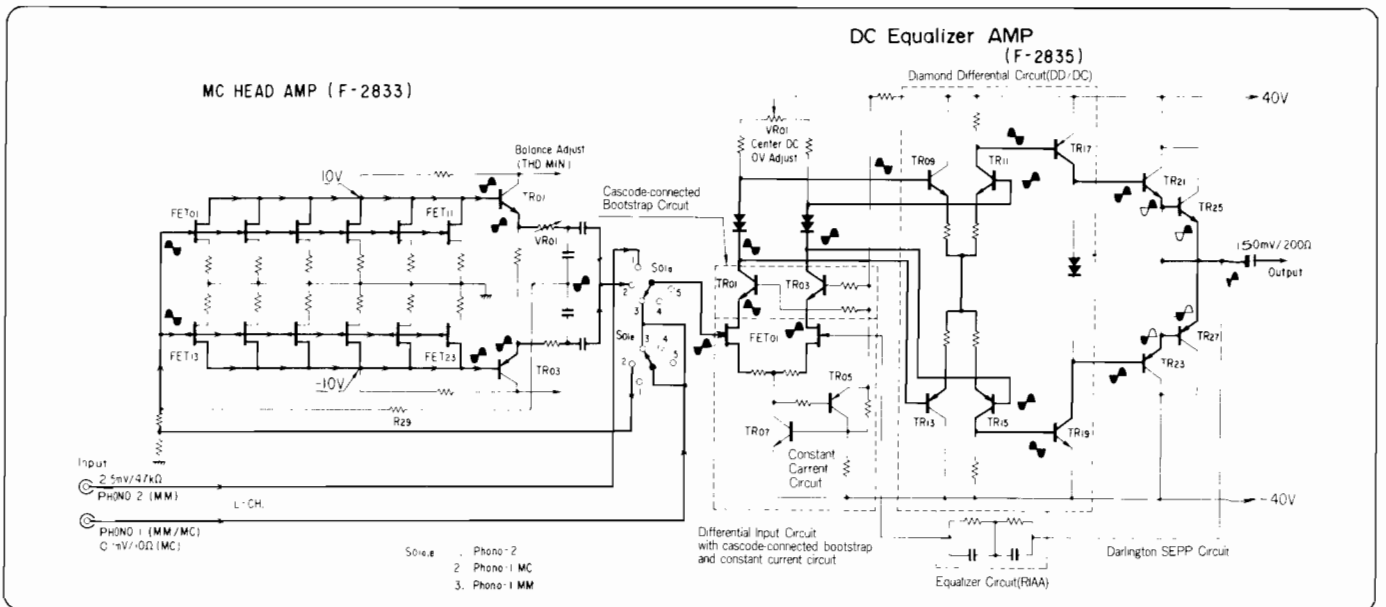

● MC Head Amp and Phono Equalization Circuit (Refer to Fig. 2-1)

The circuit configuration from MC head Amp to output of power amp stage used in AU-919 is a fully Push-pull DC amp with direct coupled input-capacitor-less DC amplifier. In order to ignore time constant with lagging or leading phase caused by input capacitor, FET input circuits are employed. By this, higher slew-rate and low-noise factor can be obtained.

1) MC (Moving Coil) type cartridge generally requires head amp to boost up weak signal from the stylus. The pre-amp section of AU-919 includes this head amp and conventional phono equalizer circuit for MM (Moving Magnet) type cartridge. MC type cartridge provides high frequency performance and excellent tonal quality, but as its output voltage from stylus is as low as approx. 0.1mV, the MC head amp or step-up transformer is needed as mentioned above. To ensure the outstanding performance in tone quality and signal-to-noise ratio(S/N), AU-919 employs the head amp which meets with these requirements.

The circuit configuration of MC head amp in AU-919 is input-capacitor-less (ICL) direct coupled complementary circuit using low-noise and high gm FETs of P-ch and N-ch in parallel connection on both channels. The requirements of MC head amp are to provide a enough S/N ratio and gain to connect the MC head amp to conventional phono equalizer. (approximately 28dB for MC cartridge with output impedance, 10 ohms). As high gm can be obtained equivalently by connecting low-noise & high gm FET in parallel, remarkable S/N ratio and gain(gm) can be obtained.

* The relation between noise and gm of FET is indicated as shown below.

$$em = \sqrt{4 K \cdot T \cdot B \cdot R}$$

- em = Noise voltage
- K = Boltzman constant
- T = Absolute temperature
- B = Band width
- R = Channel resistance of FET (= 1/gm)

Channel resistance R of FET is equal to 1/gm. By this, when FETs are connected in parallel, the total gm becomes higher and S/N ratio is excessively improved.

On AU-919, -154dB of total noise level under equivalent input is obtained. The circuit as shown in Fig. 2-1 uses ICL construction with total six low-noise Dual-FETs per channel (in case of using rank K2 of the FET) in parallel push-pull connection, and Diamond differential DC(DD/DC) circuit with fully push-pull transistor in output stage of the pre-amp section.

2) Phono equalizer circuit is input-capacitor-less (ICL) direct coupled DC equalizer amp employing DD/DC circuit. The output impedance on this circuit is as low as 200 ohms, S/N ratio better than 90dB and the deviation of RIAA equalization curve within ±0.2%. In addition, the slew rate of the equalization circuit itself is excessively high, 200V/μsec.

The circuit configuration of pre-amp section as shown in Fig. 2-1 is that the first stage is differential input circuit of Dual-FET with cascode-connected bootstrap, and high performance constant current circuit to avoid tonal coloration, phase shift and external noise, and second and third stage include DD/DC circuit with high driving capability. The output stage is composed of Darlington-connected SEPP circuit.

The features of the constant current circuit and the bootstrap circuit are simply explained below, description of DD/DC circuit is on the next page.

* Constant Current Circuit
Common mode rejection ratio and power supply rejection ratio, as an advantage of differential amplifier, can be more improved by adding the constant current circuit.

* Cascode bootstrap circuit
This circuit allows the following features as differential amplifier using low-noise Dual-FET.

1. Gate leak current is almost ignored by making voltage between Drain and Source of FET low.
2. As mirror effect is decreased, the frequency response of high range is more extended.
3. The distortion caused by voltage dependence of negative feedback capacitance is decreased.
4. Linear response can be highly improved.

2-2. Operation and Features of Diamond Differential DC(DD/DC) Circuit

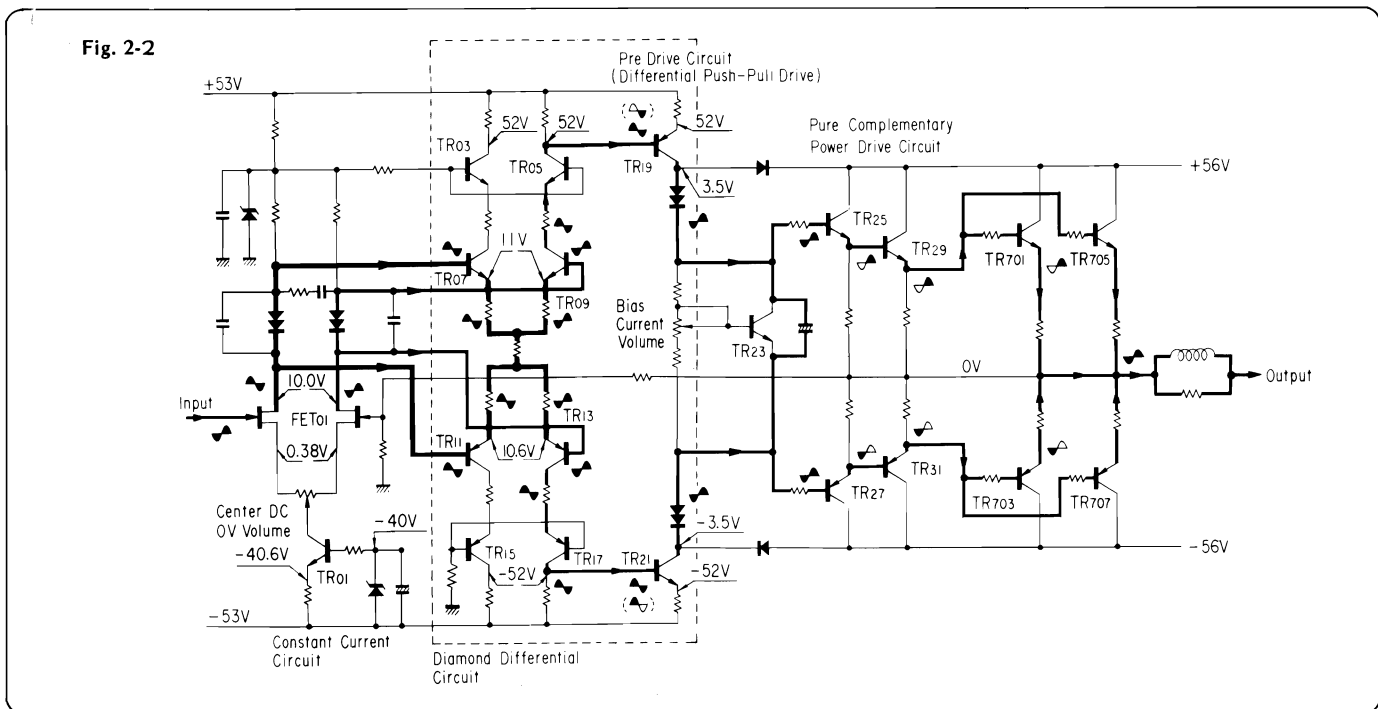

● Operation and Features of Diamond Differential DC(DD/DC) Circuit (Refer to Fig. 2-2)

1. Features

- 1) The DD/DC circuit has been developed based on Sansui's latest electronic technology and our sound policy which have been living in our tradition since a series of Sansui AU-517 & AU-717. That is, the performance of this AU-D919 is positively pursued and improved in dynamic characteristics as well as in static characteristics.
- 2) By improving open-loop characteristics to perform NFB properly and providing sufficient current margin for this circuit, TIM (Transient Intermodulation) distortion has been able to be reduced.

2. NFB and TIM distortion

As shown in Fig. 2-3, in a conventional power amplifier, an NF signal delays due to time constant of impedance element, and is operated with an input signal. As by this lagging, the phase of NF signal does not coincide with that of input signal, it is not possible to feed back the signal instantaneously containing transient components such as music with various harmonics. As a result, it brings TIM distortion which the waveform of output signal clips instantaneously. For this reason, the input signal can not be purely amplified and distortion is incurred.

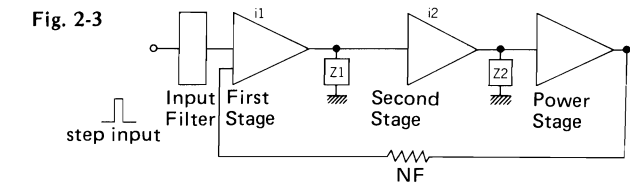

Taking into consideration on TIM distortion and NFB, they are essential for enhancement of better sound quality in dynamic characteristics, also NFB is very effective for following points.

- 1) Improvement of non-linear distortion.
- 2) Stabilization of gain against temperature drift, caused by current-flows, and fluctuation of power source voltage.
- 3) Reduction of amplifier noise.
- 4) Improvement of input and output impedance.

On the other hand, Fig. 2-4 below shows the change of the required current to provide NFB. This Fig. shows that it is necessary to increase the required current in order to increase the NFB and that the more open-loop characteristics becomes narrow, the more the required current becomes large. This means that if ample current margin is not available, TIM distortion will be arised.

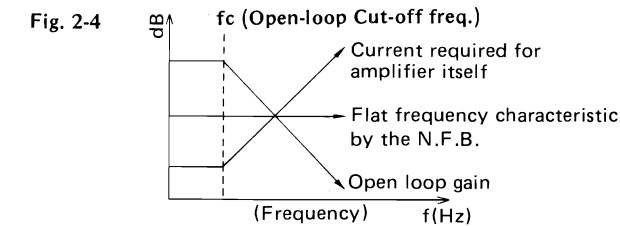

3. Prevention of TIM distortion

The prevention methods of TIM distortion are as follows:

- 1) To minimize NFB amount
- 2) To apply local feedback to the voltage amplification stage in order to improve main feedback.
- 3) To apply current as much as possible into the voltage amplification stage.
- 4) To connect a filter so that a transient input signal does not enter into the input stage beyond response of the amplifier.
- 5) To adopt an input capacitor providing lagging-phase in addition to the conventional mirror type circuit, in order to achieve 2-pole phase compensation, and at the same time, to enhance the stability by carrying out leading-phase compensation.

This AU-919 adopts the abovementioned methods 1) to 5), also the DD/DC circuit is designed to achieve the subject above item 3). As shown in Fig.2-3, when figuring out current values required for each voltage amplification stage of the amplifier, assuming that the most severe input (an input which is large enough to operate the amplifier and contains infinite frequency components) is applied to the amplifier, it is found that large current is required for second and its following stages of this section. Therefore, AU-919 includes the DD/DC circuit to prevent annoying TIM distortion.

4. Operation of Diamond Differential DC Circuit for Large Current Drive

* DD/DC circuit which is one of methods to prevent TIM distortion can supply an amplifier itself with large current required.

1) Fig. 2-7 shows the fundamental circuit of DD/DC section. The voltage differential circuit consists of TR07 and TR09 as well as TR11 and TR13. On the other hand, the current differential circuit consists of TR07 and TR13 as well as TR09 and TR11.

Fig. 2-5 Current Differential Circuit

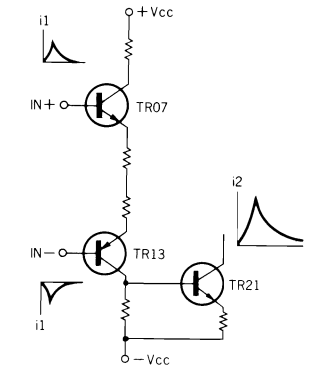

Fig.2-7 Fundamental Circuit of DD/DC section

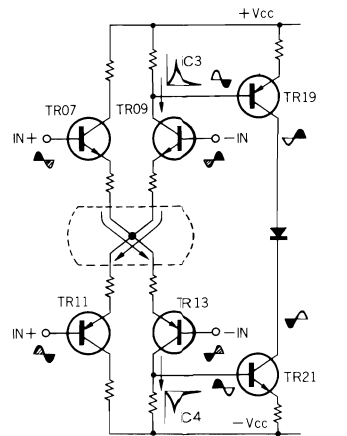
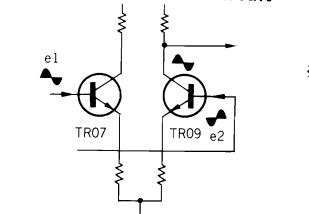

Fig. 2-6 Voltage Differential Circuit



※ In the above Fig.2-7, the cascode-connected circuit consisting of TR03, TR05, TR15 and TR17 is omitted.

Fig. 2-5 shows the current differential circuit. Fig. 2-6 shows the voltage differential circuit. In Fig. 2-7, TR07 and TR09 as well as TR11 and TR13 perform voltage differential amplification under an audible signal frequency band. When signals including transient or high frequency components is applied to input in Fig. 2-5, the operation of this stage shifts from voltage differential amplification to current differential amplification consisting of TR07 and TR13 as well as of TR09 and TR11, which let the large current flow into this stage. Above function results the improvements of rise-time and slew rate, in other word, it brings the reduction of TIM distortion.

2) The detailed operation of the current differential circuit is as follows:

The complementary circuit in Fig.2-5 consists of TR07 and TR13 and two input signals into these TR07 and TR13 are anti-phase each other, therefore, only when a transient signal including positive (+) side component into TR07 and negative (-) side into TR13 is applied to the inputs, the circuit functions and outputs only half wave with large amount of current each other from two outputs. TR09 and TR11 perform the similar function in Fig.2-7, and the output signals are out-of-phase each other with half wave, so that TR19 and TR21 in next stage operate as a push-pull function and large current is able to be flowed.

3. ADJUSTMENTS

- Notes: 1. Level Volume Minimum
 2. Room Temperature 18°C ~ 28°C
 (65°F ~ 83°F)

3. When replacing some parts or circuit board, refer to description in REMARKS.
 4. For this adjustment, run the unit for more than 3 minutes after the power is switched ON.

3-1. MC Head Amp (F-2833) Adjustment (See Fig. 3-1 & 3-4)

STEP	SUBJECT	MEASURE OUTPUT	ADJUST	ADJUST FOR	REMARKS
1	Voltage Adj. L-ch + side	Between chassis (GND) and one of Drains of FET01, FET03, FET05, FET07, FET09, FET11 (between GND and Ⓐ in Fig. 3-1) Each Drain of all FETs (2SK163) commonly connected.	VR03 (L-ch) F-2833	+10V ± 1V	Before turning ON power switch, set VR01, VR05, VR03 (R-ch) and VR04, VR06, VR02 (L-ch) to center position.
2	R-ch + side	Between chassis (GND) and one of Drains of FET02, FET04, FET06, FET08, FET10, FET12 (between GND and Ⓑ in Fig. 3-1)	VR04 (R-ch) F-2833		
3	L-ch - side	Between chassis (GND) and one of Drains of FET13, FET15, FET17, FET19, FET21, FET23 (between GND and Ⓒ in Fig. 3-1) Each Drain of all FETs (2SJ44) commonly connected.	VR05 (L-ch) F-2833	-10V ± 1V	
4	R-ch - side	Between chassis (GND) and one of Drains of FET14, FET16, FET18, FET20, FET22, FET24 (between GND and Ⓓ in Fig. 3-1)	VR06 (R-ch) F-2833		
5	Balance adj. in case of using distortion meter		VR01 (L-ch) VR02 (R-ch) F-2833	Minimum distortion	

- Notes: Balance adj. in step 5 with distortion meter
 1) Feed sine-wave signal, 1 kHz to PHONO-1.
 2) Connect distortion meter to TAPE-REC input terminal and set output level of TAPE-REC to 20 volts by adjusting audio oscillator output.
 3) Add 10 ohms, 1/4W, across output terminal of audio oscillator to have impedance matching.
- Balance adj. without distortion meter
 1) VR01 Set VR01 to 2/3 position from max. point.
 2) VR02 Set VR02 to 2/3 position from min. point.

3-2. Equalizer (F-2835) Adjustment (See Fig. 3-2)

STEP	SUBJECT	MEASURE OUTPUT	ADJUST	ADJUST FOR	REMARKS
1	DC 0V Adj.	Between GND & common joint of R67, R69 (between GND and Ⓔ)	VR01 (L-ch) F-2835	DC 0V ± 50 mV	Before turning ON power switch, set VR01 & VR02 to center position.
2	DC 0V Adj.	Between GND & common joint of R68, R70	VR02 (R-ch) F-2835		

3-3. Flat Amp (F-2841) Adjustment (See Fig. 3-5)

3 STEP	SUBJECT	MEASURE OUTPUT	ADJUST	ADJUST FOR	REMARKS
1	DC 0V Adj.	Between GND & TEST POINT from emitter of TR13 through R43 (TEST POINT between ⊕ & ⊖ in Fig. 3-5)	VR01 (L-ch) F-2841	DC 0V ± 10 mV	Before turning ON power switch, set VR01 & VR02 to center position.
2	DC 0V Adj.	Between GND & TEST POINT from emitter of TR14 through R44 (TEST POINT between ⊕ & ⊖ in Fig. 3-5)	VR02 (R-ch) F-2841		

3-4. Driver Circuit (F-2839) Adjustment (See Fig. 3-3/3-4)

STEP	SUBJECT	MEASURE OUTPUT	ADJUST	ADJUST FOR	REMARKS
1	DC 0V Adj. (see Fig. 3-3)	Speaker terminal (L-CH)	VR01 (L-ch) F-2839	DC 0V ± 5 mV	Before turning ON power switch, set VR01 & VR02 to center position.
2	DC 0V Adj. (see Fig. 3-3)	Speaker terminal (R-ch)	VR02 (R-ch) F-2839		
3	Bias current Adj.	Between emitters of power transistors TR707 & TR705 (between Ⓒ & Ⓓ in Fig. 3-4)	VR03 (L-ch) F-2839	DC 20 mV ± 1 mV	• Before turning ON power switch, turn VR03 & VR04 fully counter-clockwise. This bias current adjustment converts current value into voltage by Ohm's law.
4	Bias current Adj.	Between emitters of power transistors TR706 & TR708 (between Ⓘ & Ⓢ in Fig. 3-4)	VR04 (R-ch) F-2839		

Fig. 3-1 F-2833 MC Head Amp Circuit Board (Component side)

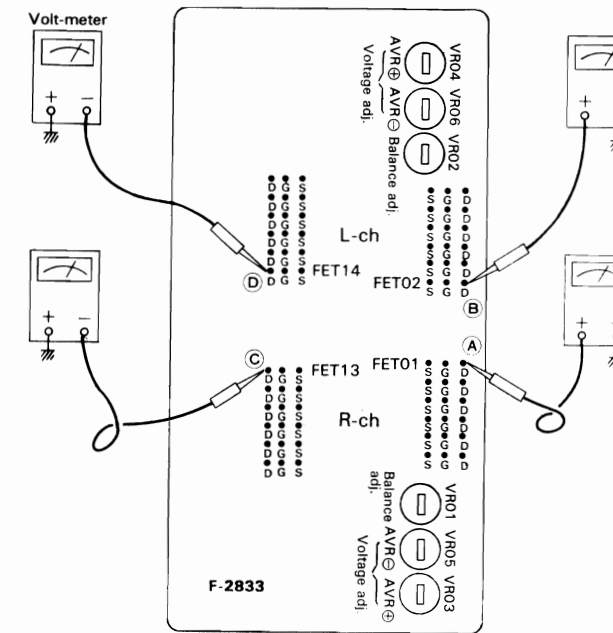

Fig. 3-2 F-2835 Equalizer Amp Circuit Board (Component side)

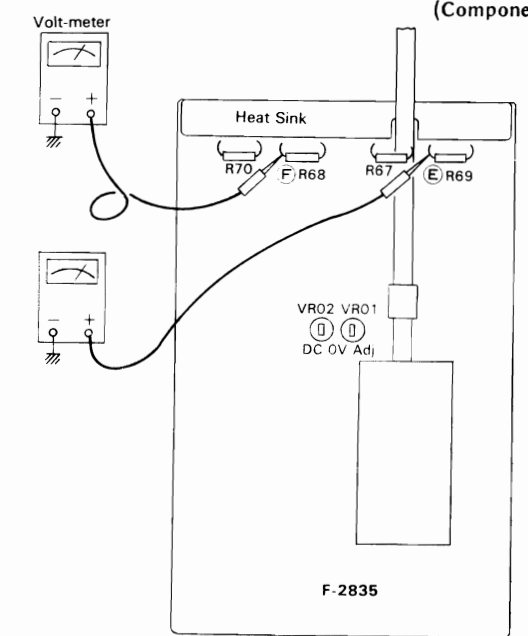

Fig. 3-3 SPEAKER TERMINAL

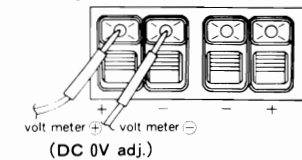
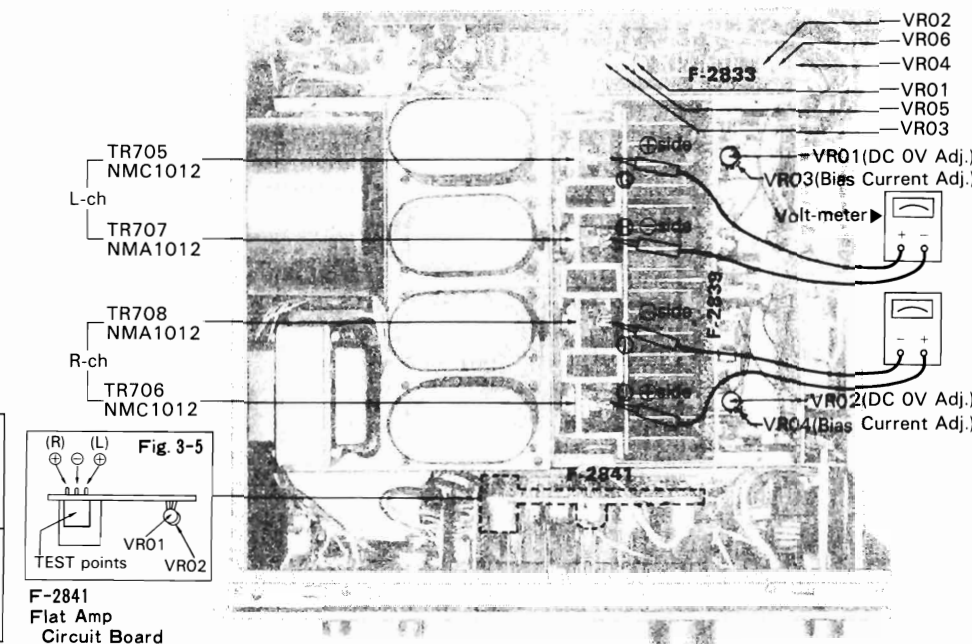

Fig. 3-4

▼ Rear Side

- Notes when replacing FETs on F-2833
 There are six kinds of FET, ranks 2SK163 (P type) and 2SJ44 (N type) on F-2833, MC Head Amp Circuit Board. When replacing some of FETs, use same rank of the 2SK163 and 2SJ44 as a pair per one channel. Also, total quantities of FETs per one channel are determined depending upon the respective FET ranks having slightly different gain (gm).
- Total quantities of 2SK163 and 2SJ44 per one channel due to different ranks

Ranks	TTL QTY per one channel	Stock No.		FET Rank here
		2SK163 (P type)	2SJ44 (N type)	
K2	6	0370341	0370331	2SK163
L1	5	0370342	0370332	
L2	5	0370343	0370333	2SJ44
M1	4	0370344	0370334	
M2	4	0370345	0370335	FET Rank here
N1	3	0370346	0370336	



4. PARTS LOCATION & PARTS LIST

4-1. F-2839 Driver Amp Circuit Board (Stock No. 7571991)

Since some of capacitors and resistors are omitted from parts lists in this Service Manual, refer to the Common Parts List for capacitors & resistors which was appended previously to each Sansui Manual.

Conductor Side

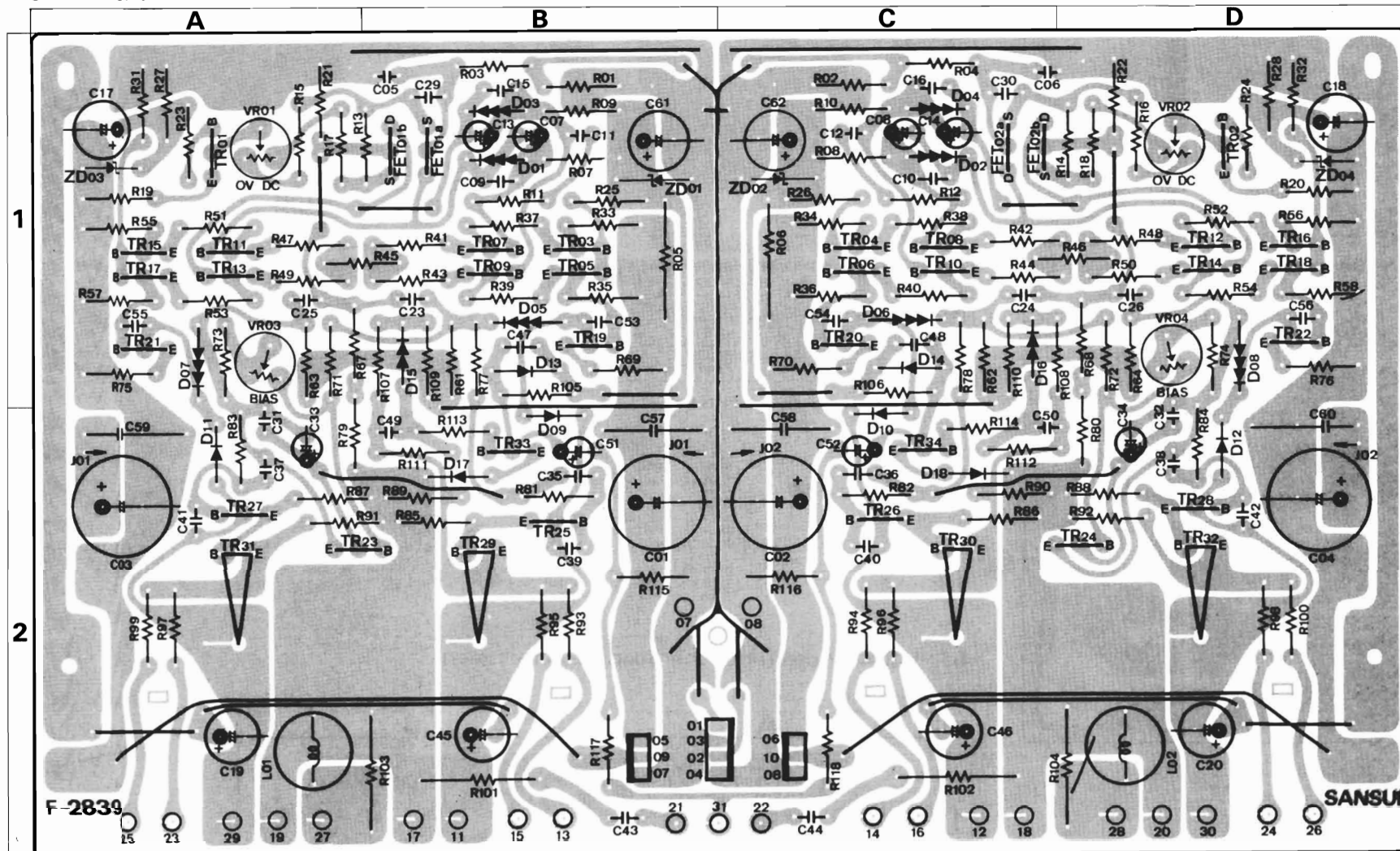

Parts List

Parts No.	Stock No.	Description	Position	Parts No.	Stock No.	Description	Position	Parts No.	Stock No.	Description	Position	Parts No.	Stock No.	Description	Position
•Transistors				•Zener Diodes				R 03.04				R 77.78			
TR01.02	0306680.1	2SC2071 B, V	1A.1D	ZD01.02	0317190	RD-27F B	1B.1C	R 05.06	0212152	1.5kΩ 2W N.I.R.	1B.1C	R 79.80	0280681	680Ω 1/3W C.R.	2A.2D
TR03.04	0306740.1	2SC1845 E, U	1B.1C	ZD03.04	0316310	RD13E B	1A.1D	R 07.08	0280392	3.9kΩ 1/3W C.R.	1B.1C	R 81.82	0280391	390Ω 1/3W C.R.	2B.2C
TR05.06	0306740.1	2SC1845 E, U	1B.1C					R 09.10	0280392	3.9kΩ 1/3W C.R.	1B.1C	R 83.84	0280391	390Ω 1/3W C.R.	2A.2D
TR07.08	0306740.1	2SC1845 E, U	1B.1C	C 01.02	0516471	470μF 63V E.C.	2B.2C	R 11.12	0280471	470Ω 1/3W C.R.	1B.1C	R 85.86	0210561	560Ω 1/3W N.I.R.	2B.2C
TR09.10	0306740.1	2SC1845 E, U	1B.1C	C 03.04	0516471	470μF 63V E.C.	2A.2D	R 13.14	0280390	39Ω 1/3W C.R.	1B.1D	R 87.88	0210561	560Ω 1/3W N.I.R.	2A.2D
TR11.12	0301090.1	2SA992 E, U	1A.1D	C 05.06	0622101	100pF 125V P.C.	1B.1C	R 15.16	0280560	56Ω 1/3W C.R.	1A.1D	R 89.90	0210470	47Ω 1/2W N.I.R.	2B.2C
TR13.14	0301090.1	2SA992 E, U	1A.1D	C 07.08	0515479	4.7μF 50V E.C.	1B.1C	R 17.18	0280560	56Ω 1/3W C.R.	1A.1D	R 91.92	0210470	47Ω 1/2W N.I.R.	2A.2D
TR15.16	0301090.1	2SA992 E, U	1A.1D	C 09.10	0680037	0.033μF 100V M.C.	1B.1C	R 19.20	0210152	1.5kΩ 1/2W N.I.R.	1A.1D	R 93.94	0210479	4.7Ω 1/2W N.I.R.	2B.2C
TR17.18	0301090.1	2SA992 E, U	1A.1D	C 11.12	0622691	680pF 125V P.C.	1B.1C	R 21.22	0280391	390Ω 1/3W C.R.	1A.1D	R 95.96	0210479	4.7Ω 1/2W N.I.R.	2A.2D
TR19.20	0301030.1	2SA939 B, V	1B.1C	C 13.14	0515479	4.7μF 50V E.C.	1B.1C	R 23.24	0280392	3.9kΩ 1/3W C.R.	1A.1D	R 97.98	0210479	4.7Ω 1/2W N.I.R.	2A.2D
TR21.22	0306680.1	2SC2071 B, V	1A.1D	C 15.16	0680037	0.033μF 100V M.C.	1B.1C	R 25.26	0280101	100Ω 1/3W C.R.	1B.1C	R 99.100	0210479	4.7Ω 1/2W N.I.R.	2A.2D
TR23.24	0306740.1	2SC1845 E, U	1A, B, 2D	C 17.18	0515470	47μF 50V E.C.	1A.1D	R 27.28	0280153	15kΩ 1/3W C.R.	1A.1D	R 101.102	0212100	10Ω 2W N.I.R.	2B.2C
TR25.26	0306680.1	2SC2071 B, V	2B.2C	C 19.20	0516339	3.3μF 63V E.C.	2A.2D	R 31.32	0280101	100Ω 1/3W C.R.	1A.1D	R 103.104	0212109	1Ω 2W N.I.R.	2B.2D
TR27.28	0301030.1	2SA939 B, V	2A.2D	C 23.24	0623309	3pF 125V P.C.	1B.1C	R 33.34	0280821	820Ω 1/3W C.R.	1B.1C	R 105.106	0280822	8.2kΩ 1/3W C.R.	1B.1C
TR29.30	0308411.2,3	2SD382 M, L, K	2B.2C	C 25.26	0623309	3pF 125V P.C.	1A.1D	R 35.36	0280821	820Ω 1/3W C.R.	1B.1C	R 107.108	0280562	5.6kΩ 1/3W C.R.	1B.1C, D
TR31.32	0303271.2,3	2SB537 M, L, K	2A.2D	C 29.30	0623320	22pF 125V P.C.	1B.1C	R 37.38	0280101	100Ω 1/3W C.R.	1B.1C	R 109.110	0280393	39kΩ 1/3W C.R.	1B.1C
TR33.34	0306740.1	2SC1845 E, U	2B.2C	C 31.32	0280041	0.047μF 100V M.C.	2A.2D	R 39.40	0280101	100Ω 1/3W C.R.	1B.1C	R 111.112	0280104	100Ω 1/3W C.R.	2B.2C
•FET				C 33.34	0515109	1μF 50V E.C.	2A.2D	R 41.42	0280151	150Ω 1/3W C.R.	1B.1C	R 113.114	0280680	68Ω 1/3W C.R.	2B.2C
FET01.02	0370310.1	2SK129 K, L	1B.1C	C 35.36	0680001	0.001μF 100V M.C.	2B.2C	R 43.44	0280151	150Ω 1/3W C.R.	1B.1C	R 115.116	0280823	8.2kΩ 1/3W C.R.	2B.2C
•Varistors				C 37.38	0680001	0.001μF 100V M.C.	2A.2D	R 45.46	0280100	10Ω 1/3W C.R.	1A, B, 1D	R 117.118	0280222	2.2kΩ 1/3W C.R.	2B.2C
D 01.02	0340170	MV-103	1B.1C	C 39.40	0623330	33pF 125V P.C.	2B.2C	R 47.48	0280151	150Ω 1/3W C.R.	1A.1D				
D 03.04	0340170	MV-103	1B.1C	C 41.42	0623330	33pF 125V P.C.	2B.2C	R 49.50	0280151	150Ω 1/3W C.R.	1A.1D				
D 15.16	0340150	MV-102	1B.1C	C 43.44	0680041	0.047μF 100V P.C.	2B.2C	R 51.52	0280101	100Ω 1/3W C.R.	1A.1D				
•Diodes				C 45.46	0516339	3.3μF 63V E.C.	2B.2C	R 53.54	0280101	100Ω 1/3W C.R.	1A.1D				
D 05.06	0310480	SV-03	1B.1C	C 47.48	0680001	0.001μF 100V P.C.	1B.1C	R 55.56	0280821	820Ω 1/3W C.R.	1A.1D				
D 07.08	0310480	SV-03	1A.1D	C 49.50	0680001	0.001μF 100V P.C.	2B.2C	R 57.58	0280821	820Ω 1/3W C.R.	1A.1D				
D 09.10	0310390	10D2 (1S2227)	2B.2C	C 53.54	0623309	3pF 125V P.C.	1B.1C	R 61.62	0280393	39kΩ 1/3W C.R.	1B.1C				
D 11.12	0310390	10D2 (1S2227)	2A.2D	C 55.56	0623309	3pF 125V P.C.	1A.1D	R 63.64	0280393	39kΩ 1/3W C.R.	1A.1D				
D 13.14	0310400	1N34A	1B.1C	C 57.58	0681018	0.22μF 400V M.C.	2B.2C	R 67.68	0280103	10kΩ 1/3W C.R.	1A.1D				
D 17.18	0311190	1S2473D	2B.2C	C 59.60	0681018	0.22μF 400V M.C.	2A.2D	R 69.70	0280121	1.2kΩ 1/3W C.R.	1B.1C				
				C 61.62	0514101	100μF 35V E.C.	1B.1C	R 71.72	0280562	5.6kΩ 1/3W C.R.	1A.1D				
								R 73.74	0280102	1kΩ 1/3W C.R.	1A.1D				
								R 75.76	0280121	1.2kΩ 1/3W C.R.	1A.1D				

4-2. F-2833 MC Head Amp Circuit Board (Stock No. 7610321)

Conductor Side

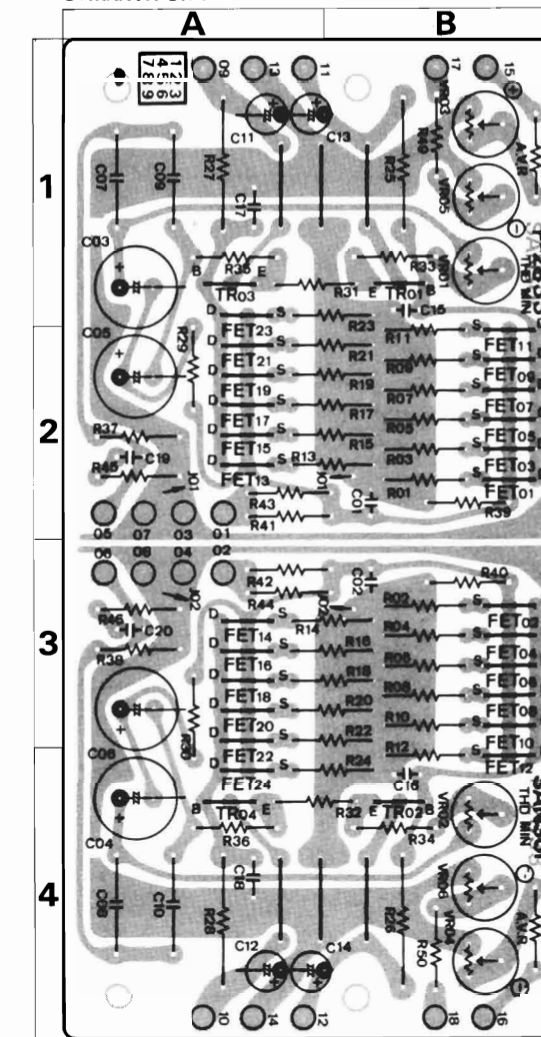

Parts List

Parts No.	Stock No.	Description	Position
•Transistors			
TR01.02	0306071.2	2SC1313 G, H	1B, 4B
TR03.04	0300470.1	2SA726(W) F, G	1A, 4A
•FET			
FET01 ~ 12	0370341 ~ 6	2SK163	2, 3A
FET13 ~ 24	0370331 ~ 6	2SK163	1, 2, 3, 4A
		K2, L1, L2, M1, M2, N1	2, 3A
		25J44	1, 4A
C 01.02	0680001	0.001μF 100V P.C.	2B, 3B
C 03.04	0513101	100μF 25V E.C.	1A, 4A
C 05.06	0513101	100μF 25V E.C.	2A, 3A
C 07.08	0602109	1μF 100V M.C.	1A, 4A
C 09.10	0602109	1μF 100V M.C.	1A, 4A
C 11.12	0515100	10μF 50V E.C.	1A, 4A
C 13.14	0515100	10μF 50V E.C.	1A, 4A
C 15.16	0623101	100pF 125V P.C.	1B, 4B
C 17.18	0623101	100pF 125V P.C.	1A, 4A
C 19.20	0622102	1000pF 125V P.C.	2A, 3A
R 01 ~ 08	0280229	2.2kΩ 1/3W C.R.	2B, 3B
R 13 ~ 24	0280229	2.2kΩ 1/3W C.R.	1, 2, 3, 4B
R 25.26	0212471	470Ω 2W N.I.R.	1B, 4B
R 27.28	0212471	470Ω 2W N.I.R.	1A, 4A
R 29.30	0280271	270Ω 1/3W C.R.	2A, 3A
R 31.32	0280332	3.3kΩ 1/3W C.R.	1A, 4A, B
R 33.34	0280330	33Ω 1/3W C.R.	1B, 4B
R 35.36	0280101	100Ω 1/3W C.R.	1A, 4A
R 37.38	0280223	22kΩ 1/3W C.R.	2A, 3A
R 39.40	0280330	33Ω 1/3W C.R.	2B, 3B
R 41.42	0280109	1Ω 1/3W C.R.	2A, 3A
R 43.44	0280109	1Ω 1/3W C.R.	2A, 3A
R 45.46	0280820	82Ω 1/3W C.R.	2A, 3A
R 47.48	0280103	10kΩ 1/3W C.R.	1B, 4B
R 49.50	0280103	10kΩ 1/3W C.R.	1B, 4B
R 53.54	0280390	39Ω 1/3W C.R.	1B, 4B
R 55.56	0280221	220Ω 1/3W C.R.	
VR01.02	1033590	Volume, 220Ω (B) (Balance Adjust)	1B, 4B
VR03 ~ 06	1035400	Volume, 33kΩ (B) (Voltage Regulator Adjust)	1, 4B

4-3. F-2835 Equalizer Amp Circuit Board (Stock No. 7551331)

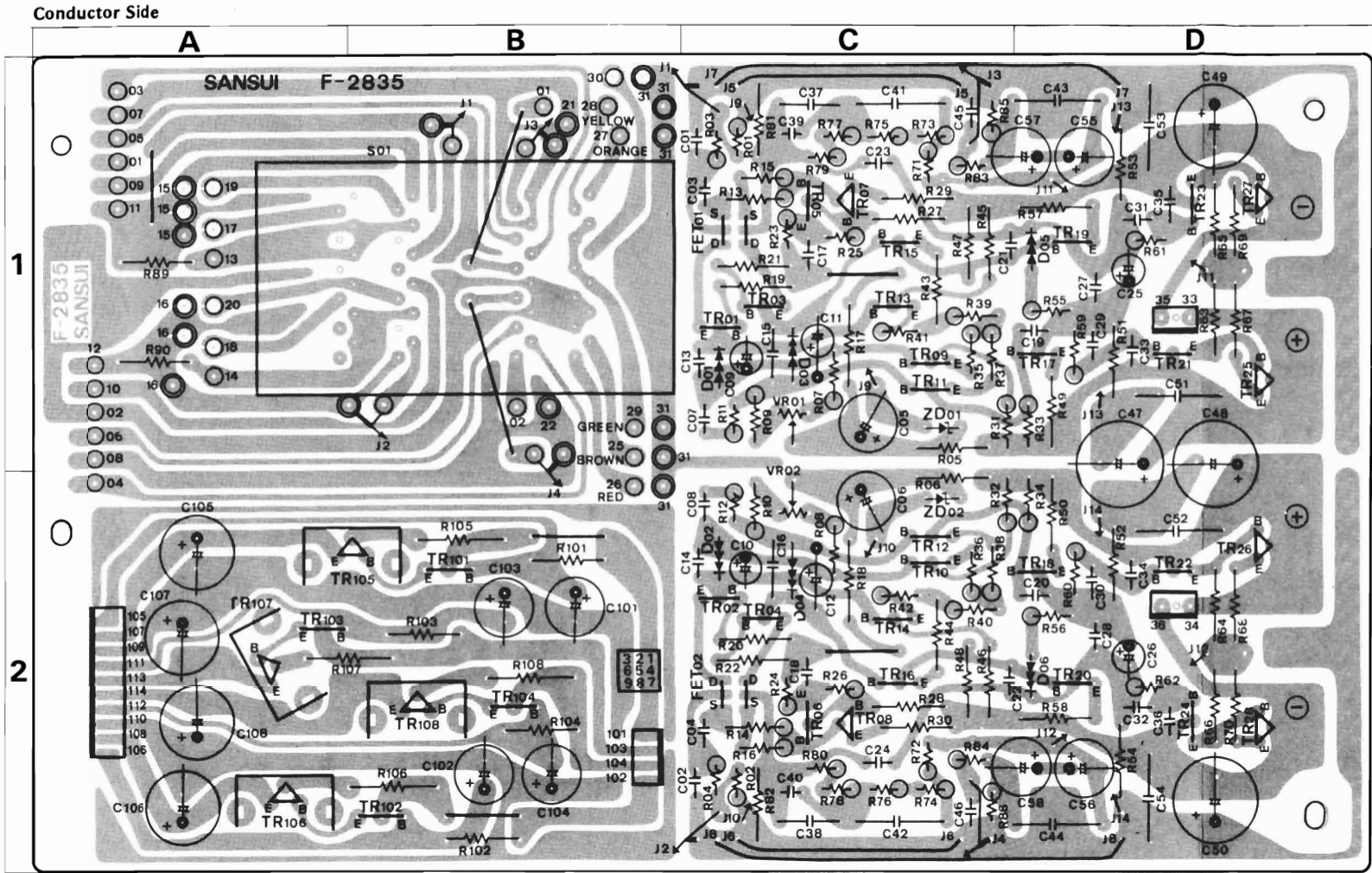

Parts List				
Parts No.	Stock No.	Description	Position	
•Transistors				
TR01,02	0306740,1	2SC1845 E, U	1C,2C	
TR03,04	0306740,2	2SC1845 E, U	1C,2C	
TR05,06	0301090,1	2SA992 E, U	1C,2C	
TR07,08	0306680,1	2SC2071 B, V	1C,2C	
TR09,10	0306740,1	2SC1845 E, U	1C,2C	
TR11,12	0306740,1	2SC1845 E, U	1C,2C	
TR13,14	0301090,1	2SA992 E, U	1C,2C	
TR15,16	0301090,1	2SA992 E, U	1C,2C	
TR17,18	0301090,1	2SA992 E, U	1D,2D	
TR19,20	0306740,1	2SC1845 E, U	1D,2D	
TR21,22	0306740,1	2SC1845 E, U	1D,2D	
TR23,24	0301090,1	2SA992 E, U	1D,2D	
TR25,26	0306680,1	2SC2071 B, V	1D,2D	
TR27,28	0301030,1	2SA939 B, V	1D,2D	
TR101,102	0306290,1	2SC1400 (1) E, U	2B	
TR103,104	0300890,1	2SA750 (3) E, U	2A,2B	
TR105,106	0308611,2	2SD357 D, E	2A, B,2A	
TR107,108	0303441,2	2SB527 D, E	2A,2B	
•FET				
FET01,02	0370350	2SK146Y	1C,2C	
•Varistors				
D 01,02	0340170	MV-103	1C,2C	
D 03,04	0340170	MV-103	1C,2C	
D 05,06	0340170	MV-103	1D,2D	
•Diodes				
ZD01,02	0316530	RD27E B	1C,2C	
C 01,02	0622151	150pF 125V P.C.	1C,2C	
C 03,04	0623220	22pF 125V P.C.	1C,2C	
C 05,06	0515330	33uF 50V E.C.	1C,2C	
C 07,08	0680014	3600pF 125V M.C.	1C,2C	
C 09,10	0515109	1uF 50V E.C.	1C,2C	
C 11,12	0515109	1uF 50V E.C.	1C,2C	
C 13,14	0680037	0.033uF 100V M.C.	1C,2C	
C 15,16	0680037	0.033uF 100V M.C.	1C,2C	
C 17,18	0622102	1000pF 125V P.C.	1C,2C	
C 19,20	0623609	6pF 125V P.C.	1D,2D	
C 21,22	0623609	6pF 125V P.C.	1C,2C, D	
C 23,24	0623909	9pF 125V P.C.	1C,2C	
C 25,26	0515109	1uF 50V E.C.	1D,2D	
C 27,28	0680041	0.047uF 100V M.C.	1D,2D	
C 29,30	0680001	0.001uF 100V M.C.	1D,2D	
C 31,32	0680001	0.001uF 100V M.C.	1D,2D	
C 33,34	0623220	22pF 125V P.C.	1D,2D	
C 35,36	0623220	22pF 125V P.C.	1D,2D	
C 37,38	0682023	0.033uF 100V M.C.	1C,2C	
C 39,40	0622202	2000pF 125V P.C.	1C,2C	
C 41,42	0682037	0.12uF 100V M.C.	1C,2C	
C 43,44	0681001	0.47uF 100V M.C.	1D,2D	
C 45,46	0680013	0.0033uF 100V M.C.	1C,2C	
C 47,48	0515331	330uF 50V E.C.	1D,2D	
C 49,50	0515331	330uF 50V E.C.	1D,2D	
C 51,52	0681001	0.47uF 250V M.C.	1D,2D	
C 53,54	0681001	0.47uF 250V M.C.	1D,2D	
C 55,56	0514101	100uF 35V E.C.	1D,2D	
C 57,58	0514101	100uF 35V E.C.	1D,2D	
C 105,106	0514221	220uF 35V E.C.	2A	
C 107,108	0514221	220uF 35V E.C.	2A	
C 707,708	0681021	1uF 250V M.C.	1C,2C	
C 709,710	0681021	1uF 250V M.C.	1C,2C	
R 01,02	0280104	100kΩ 1/3W C.R.	1C,2C	
R 03,04	0280470	47kΩ 1/3W C.R.	1C,2C	
R 05,06	0210102	1.0kΩ 1/2W N.I.R.	1C,2C	
R 07,08	0280182	1.8kΩ 1/3W C.R.	1C,2C	
R 09,10	0280470	47kΩ 1/3W C.R.	1C,2C	
R 11,12	0280470	47kΩ 1/3W C.R.	1C,2C	
R 13,14	0280229	2.2kΩ 1/3W C.R.	1C,2C	
R 15,16	0280229	2.2kΩ 1/3W C.R.	1C,2C	
R 17,18	0280333	33kΩ 1/3W C.R.	1C,2C	
R 19,20	0280101	100Ω 1/3W C.R.	1C,2C	
R 21,22	0280101	100Ω 1/3W C.R.	1C,2C	
R 23,24	0280101	100Ω 1/3W C.R.	1C,2C	
R 25,26	0280564	560kΩ 1/3W C.R.	1C,2C	
R 27,28	0280333	33kΩ 1/3W C.R.	1C,2C	
R 29,30	0210222	2.2kΩ 1/2W C.R.	1C,2C	
R 31,32	0280821	820Ω 1/3W C.R.	1C,2C	
R 33,34	0280821	820Ω 1/3W C.R.	1D,2D	
R 35,36	0280181	180Ω 1/3W C.R.	1C,2C	
R 37,38	0280181	180Ω 1/3W C.R.	1C,2C	
R 39,40	0280680	68Ω 1/3W C.R.	1D,2D	
R 41,42	0280181	180Ω 1/3W C.R.	1C,2C	
R 43,44	0280181	180Ω 1/3W C.R.	1C,2C	
R 45,46	0280821	820Ω 1/3W C.R.	1C,2C	
R 47,48	0280821	820Ω 1/3W C.R.	1C,2C	
R 49,50	0280121	120Ω 1/3W C.R.	1D,2D	
R 51,52	0280393	39kΩ 1/3W C.R.	1D,2D	
R 53,54	0280393	39kΩ 1/3W C.R.	1D,2D	
R 55,56	0280331	330Ω 1/3W C.R.	1D,2D	
R 57,58	0280121	120Ω 1/3W C.R.	1D,2D	
R 59,60	0280391	390Ω 1/3W C.R.	1D,2D	
R 61,62	0280391	390Ω 1/3W C.R.	1D,2D	
R 63,64	0280331	330Ω 1/3W C.R.	1D,2D	
R 65,66	0280331	330Ω 1/3W C.R.	1D,2D	
R 67,68	0210330	33Ω 1/2W N.I.R.	1D,2D	
R 69,70	0210330	33Ω 1/2W N.I.R.	1D,2D	
R 71,72	0280470	47kΩ 1/3W C.R.	1C,2C	
R 73,74	0231203	20kΩ 1/2W M.R.	1C,2C	
R 75,76	0231682	6.8kΩ 1/2W M.R.	1C,2C	
R 77,78	0231182	1.8kΩ 1/2W M.R.	1C,2C	
R 79,80	0231391	390Ω 1/2W M.R.	1C,2C	
R 81,82	0231470	47kΩ 1/2W M.R.	1C,2C	
R 83,84	0280561	560Ω 1/3W C.R.	1C,2C	
R 85,86	0280104	100kΩ 1/3W C.R.	1C,2C	
R 87,88	0280331	330Ω 1/3W C.R.	1C,2C	
R 89,90	0280104	100kΩ 1/3W C.R.	1A	
R 101,102	0280822	8.2kΩ 1/3W C.R.	2B	
R 103,104	0380822	8.2kΩ 1/3W C.R.	2B	
R 105,106	0211101	100Ω 1W N.I.R.	2A	
R 107,108	0211101	100Ω 1W N.I.R.	2A, B,2B	
VR01,02	1034170, 1	220Ω (B) Volume (DC OV Adjust)	1C,2C	
S 01	1104380	Rotary Switch, Input Selector	1A, B	
	2411560	3P Connector		
	2411570	2.5MMP Connector		
	2411630	10P Connector		

4-4. F-2845 Power Supply Circuit Board for power amp section (Stock No. 7503011)

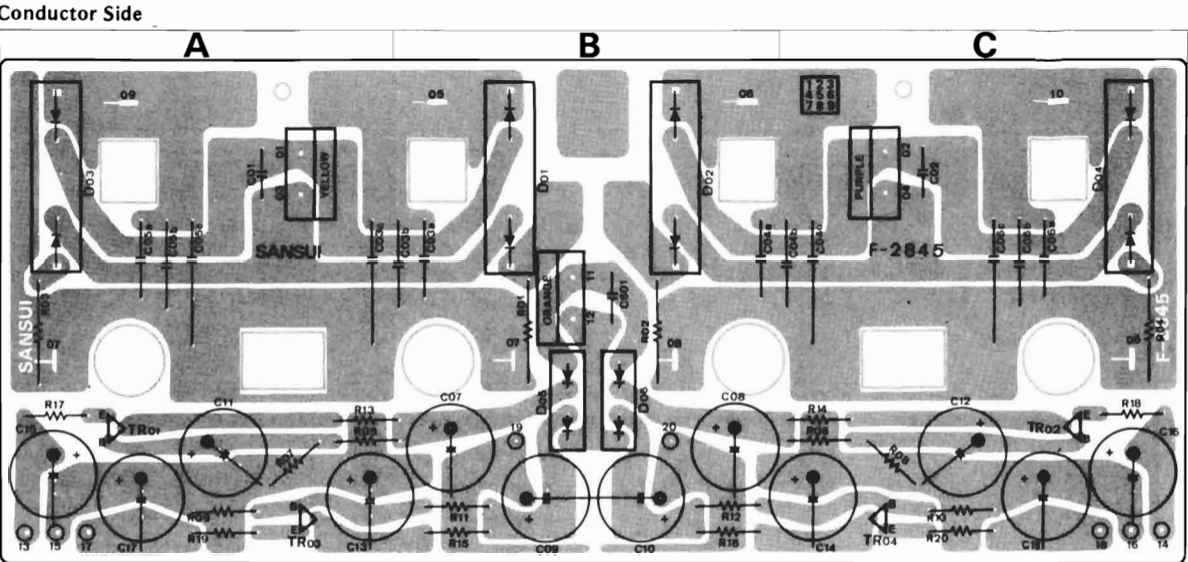

Parts List				
Parts No.	Stock No.	Description	Position	
•Transistors				
TR01,02	0308611, 2	2SD357 D, E	A, C	
TR03,04	0303441, 2	2SB527 D, E	A, C	
•Diodes				
D 01,02	0311290	SS-3	B	
D 03,04	0311300	SS-3R	A, C	
D 05,06	0311700	RB-152	B	
•Resistors				
C 01,02	0606108	0.1uF 250V M.C.	A, C	
C 03,04	0681001	0.47uF 250V M.C.	A, B, B, C	
C 05,06	0681001	0.47uF 250V M.C.	A, C	
C 15,16	0516221	220uF 63V E.C.	A, C	
C 17,18	0516221	220uF 63V E.C.	A, C	
•Capacitors				
C 601	0606108	0.1uF 250V M.C.	B	
R 01,02	0212332	3.3kΩ 2W N.I.R.	B	
R 03,04	0212332	3.3kΩ 2W N.I.R.	A, C	
R 05,06	0280153	15kΩ 1/3W C.R.	A, C	
R 07,08	0280563	56kΩ 1/3W C.R.	A, C	
R 09,10	0280563	56kΩ 1/3W C.R.	A, C	
R 11,12	0280153	15kΩ 1/3W N.I.R.	B	
R 13,14	0210100	10Ω 1/2W N.I.R.	A, C	
R 15,16	0210100	10Ω 1/2W N.I.R.	B	
R 17,18	0210100	10Ω 1/2W N.I.R.	A	
R 19,20	0210100	10Ω 1/2W N.I.R.	A, C	

4-5. F-2840 Protector Circuit Board (Stock No. 7596631)

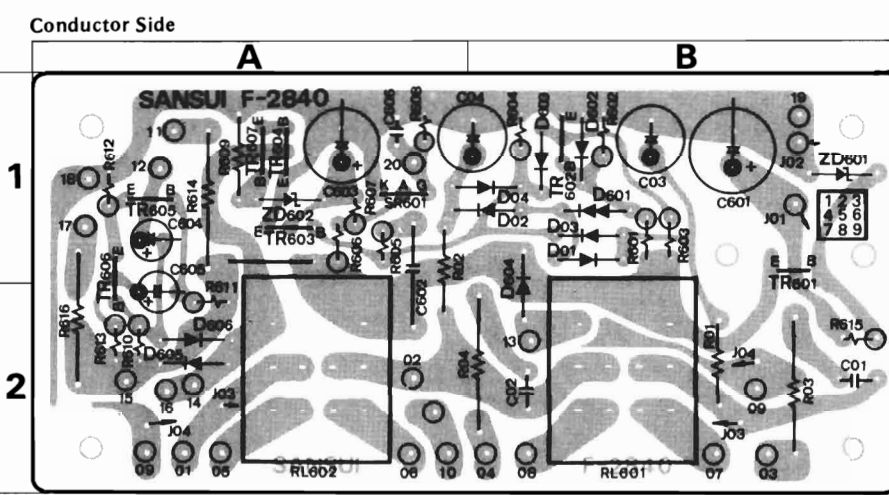

Parts List				
Parts No.	Stock No.	Description	Position	
•Transistors				
TR601	0308611, 2	2SD357 D, E	1B	
TR602	0305951, 2	2SC945 O, P	1B	
TR603	0305951, 2	2SC945 O, P	1A	
TR604	0308521, 2	2SD438 E, F	1A	
TR605	0305951, 2	2SC945 O, P	1A	
TR606	0305951, 2	2SC945 O, P	1, 2A	
TR607	0305951, 2	2SC945 O, P	1A	
•Diodes				
D 01,02	0311160	1S2473D	1B	
D 03,04	0311160	1S1588	1B	
D 602, 603	0311160	1S2473D	1B	
	or 0311180	1S1588		
	or 0311180	1S1588		
	or 0311180	1S1588		
D 604, 605	0310340	10D1	2B, 2A	
D 606	0311160	1S2473D	2A	
	or 0311180	1S1588		
•Varistor				
D 601	0340150	MV-12	1B	
•Zener Diodes				
ZD601	0316510	RD24E B	1B	
ZD602	0316390	RD6.2E B	1A	
SR 601	0350020	2SF656 SCR	1A	
R 604	0280393	30kΩ 1/3W C.R.	1B	
R 605	0280104	100kΩ 1/3W C.R.	1A	
R 606	0281472	4.7kΩ 1/3W C.R.	1A	
R 607	0280333	33kΩ 1/3W C.R.	1A	
R 608	0280102	1kΩ 1/3W C.R.	1A	
R 609	0280333	33kΩ 1/3W C.R.	1A	
R 610	0280104	100kΩ 1/3W C.R.	2A	
R 611	0280104	100kΩ 1/3W C.R.	2A	
R 612	0280121	120Ω 1/3W C.R.	1A	
R 613	0280682	6.8kΩ 1/3W I.R.	2A	
R 614	0212152	1.5kΩ 2W N.I.R.	1A	
R 615	0200102	10kΩ 1/2W I.I.F.	2B	
R 616	0212152	1.5kΩ 2W N.I.R.	2A	
R 617	0280330	33kΩ 1/3W C.R.	2B, 2A	
R 619	0280330	33kΩ 1W N.I.R.	1A	
RL601, 602	1150400	Relay	2B, 2A	
	or 1150480			
	or 1150490			

4-6. F-2841 Flat Amp Circuit Board (Stock No. 7596641)

Conductor Side

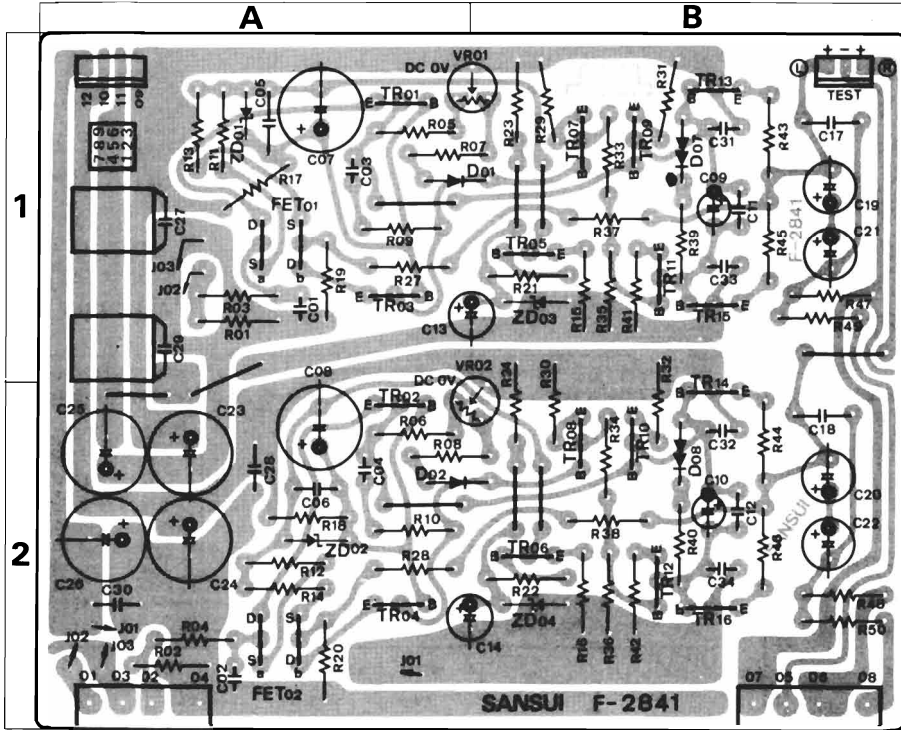

Parts No.	Stock No.	Description	Position
•Varistors			
D 07, 08	0340150	MV-12	1B,2B
•Zener Diodes			
ZD01, 02	0316240	RD-9	1A,2A
ZD03, 04	0316390	RD6E 2 B	1B,2B
C 01, 02	0623330	33pF 125V P.C.	1A,2A
C 03, 04	0622391	390pF 125V P.C.	1A,2A
C 05, 06	0680049	0.1μF 100V M.C.	1A,2A
C 07, 08	0513221	220μF 25V E.C.	1A,2A
C 09, 10	0515109	1μF 50V E.C.	1B,2B
C 11, 12	0680041	0.047μF 100V M.C.	1B,2B
C 15, 16	0623509	5pF 125V P.C.	
C 17, 18	0680061	0.33μF 100V M.C.	1B,2B
C 19, 20	0513101	100μF 25V E.C.	1B,2B
C 21, 22	0513101	100μF 25V E.C.	1B,2B
C 23, 24	0515101	100μF 50V E.C.	2A
C 25, 26	0515101	100μF 50V E.C.	2A
C 27, 28	0680057	0.22μF 100V M.C.	1A,2A
C 29, 30	0680057	0.22μF 100V M.C.	1A,2A
C 31, 32	0623509	5pF 125V P.C.	1B,2B
C 33, 34	0623509	5pF 125V P.C.	1B,2B
C 35, 36	0623309	3pF 125V P.C.	
C 37, 38	0623309	3pF 125V P.C.	
R 35, 36	0280272	2.7kΩ 1/3W C.R.	1A,2A
R 37, 38	0280273	27kΩ 1/3W C.R.	1A,2A
R 39, 40	0280820	82Ω 1/3W C.R.	1A,2A
R 07, 08	0280272	2.7kΩ 1/3W C.R.	1A, B,2A
R 09, 10	0280471	470Ω 1/3W C.R.	1A,2A
R 11, 12	0280220	22Ω 1/3W C.R.	1A,2A
R 13, 14	0280220	22Ω 1/3W C.R.	1A,2A
R 15, 16	0280102	1kΩ 1/3W C.R.	1B,2B
R 17, 18	0280333	33kΩ 1/3W C.R.	1A,2A
R 19, 20	0280122	1.2kΩ 1/3W C.R.	1A,2A
R 21, 22	0280101	100Ω 1/3W C.R.	1B,2B
R 23, 24	0280223	22kΩ 1/3W C.R.	1B,2B
R 27, 28	0280222	2.2kΩ 1/3W C.R.	1A,2A
R 29, 30	0280272	2.7kΩ 1/3W C.R.	1B,2B
R 31, 32	0280102	1kΩ 1/3W C.R.	1B,2B
R 33, 34	0280101	100Ω 1/3W C.R.	1B,2B
R 35, 36	0280272	2.7kΩ 1/3W C.R.	1B,2B
R 37, 38	0280223	22kΩ 1/3W C.R.	1B,2B
R 39, 40	0280820	82Ω 1/3W C.R.	1B,2B
R 41, 42	0280102	1kΩ 1/3W C.R.	1B,2B
R 43, 44	0210470	47Ω 1/2W N.I.R.	1B,2B
R 45, 46	0210470	47Ω 1/2W N.I.R.	1B,2B
R 47, 48	0280223	22kΩ 1/3W C.R.	1B,2B
R 49, 50	0280101	100Ω 1/3W C.R.	1B,2B
VR01, 02	1033610	Volume, 470Ω (B) (Center DC 0V Adjust)	1A,B,2A,B

Parts List

Parts No.	Stock No.	Description	Position	Parts No.	Stock No.	Description	Position
•Transistors				TR13, 14	0306740, 1	2SC1845 E, U	1B,2B
TR01, 02	0306071, 2	2SC1313 G, H	1A,2A	TR15, 16	0301090, 1	2SA992 E, U	1B,2B
TR03, 04	0306071, 2	2SC1313 G, H	1A,2A	•FET			
TR05, 06	0306680, 1	2SC2071 B, V	1B,2B	FET01, 02	0370310, 1	FET 2SK129 K, L	1A,2A
TR07, 08	0301090, 1	2SA992 E, U	1B,2B	•Diodes			
TR09, 10	0301090, 1	2SA992 E, U	1B,2B	D 01, 02	0311160	1S2473D	1A,B,2A,B
TR11, 12	0306740, 1	2SC1845 E, U	1B,2B		or 0311180	1S1588	

4-7. F-2844 Power Supply Circuit Board for pre-amp section(Stock No. 7503001)

Conductor Side

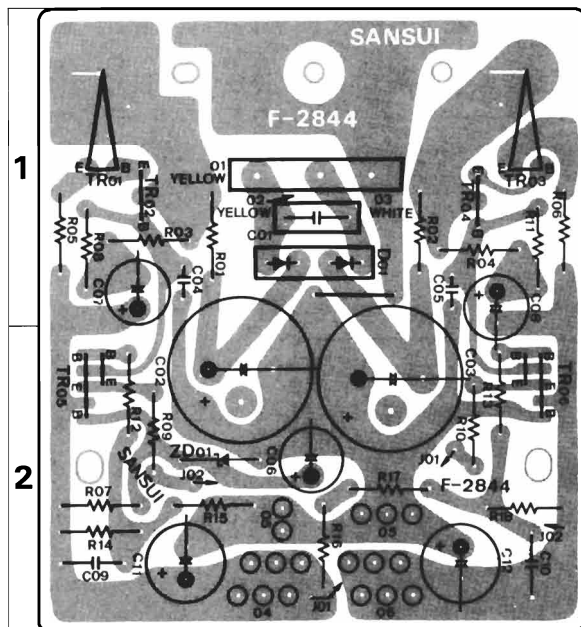

Parts List

Parts No.	Stock No.	Description	Position
•Transistors			
TR01	0308501, 2	2SD357 D, E	1
TR02	0306290, 1	2SC1400 (I) E, U	1
TR03	0303331, 2	2SB527 D, E	1
TR04	0300890, 1	2SA750 (3) E, U	1
TR05	0306730, 1	2SC2259 F, G	2
TR06	0301080, 1	2SA979 F, G	2
•Diode			
D 01	0311700	RB-152	1
•Zener Diode			
ZD01	0316510	RD24E B	2
C 01	0606108	0.1μF 250V P.C.	1
C 02, 03	0549207	100μF E.C.	2
C 09, 10	0602228	0.022μF 100WV M.C.	2
C 11, 12	0515101	100μF 50V E.C.	2
R 01, 02	0210399	3.9Ω 1/2W N.I.R.	1
R 03, 04	0280472	4.7kΩ 1/3W C.R.	1
R 05, 06	0210229	2.2kΩ 1/2W N.I.R.	1
R 07	0280222	2.2kΩ 1/3W C.R.	2
R 08	0280103	10kΩ 1/3W C.R.	1
R 09	0280333	33kΩ 1/3W C.R.	2
R 10	0280203	20kΩ 1/3W C.R.	2
R 11	0280103	10kΩ 1/3W C.R.	1
R 12, 13	0280472	4.7kΩ 1/3W C.R.	2
R 14	0280163	16kΩ 1/3W C.R.	2
R 15	0280243	24kΩ 1/3W C.R.	2
R 16, 17	0280203	20kΩ 1/3W C.R.	2
R 18	0280393	39kΩ 1/3W C.R.	2
	2410610	3P Plug Assy	

Note: The circuit boards, F-2834, F-2846, F-2838, F-2842, F-2843, F-2837, F-2928 & F-2836 are not supplied as the assembled, the individual parts on the circuit board, however, are provided for orders.

4-8. F-2834 Input Terminal Circuit Board

Conductor Side

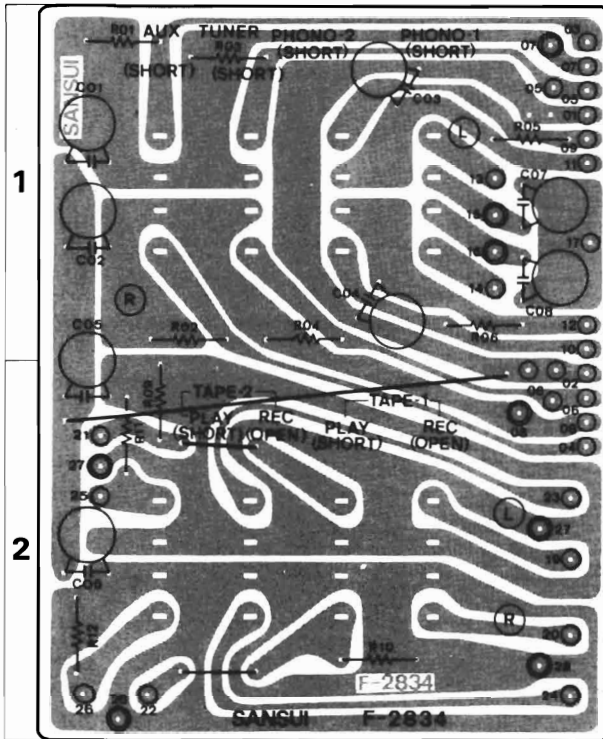

Parts List

Parts No.	Stock No.	Description	Position
R 01, 02	0280105	1M Ω 1/3W C.R.	1
R 03, 04	0280105	1M Ω 1/3W C.R.	1
R 07, 08	0280104	100k Ω 1/3W C.R.	
R 09, 10	0280105	1M Ω 1/3W C.R.	2
R 11, 12	0280105	1M Ω 1/3W C.R.	2
	2200620	4P Input Terminal (TUNER, AUX)	
	2200630	4P Input Terminal (PHONO-1, 2)	
	2200650	4P Input Terminal (TAPE-1, 2)	

4-9. F-2838 Circuit Board between Pre & Main amp

Conductor Side

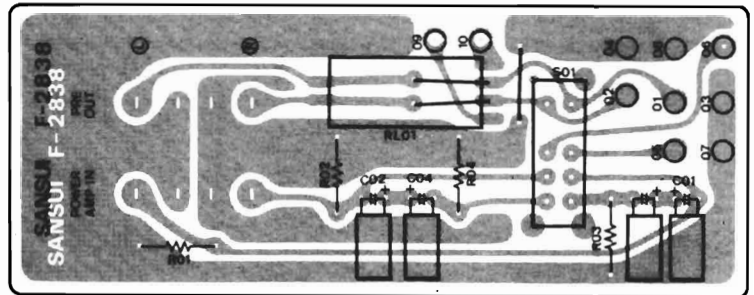

Parts List

Parts No.	Stock No.	Description	Position
C 01, 02	0515100	10 μ F 50V E.C.	
C 03, 04	0515100	10 μ F 50V E.C.	
R 01, 02	0280105	1M Ω 1/3W C.R.	
R 03, 04	0280105	1M Ω 1/3W C.R.	
RL01	1150430	Relay	
S 01	1110290	Slide Switch, Connected/Separated	
	2200650	4P Input Terminal (PRE AMP, POWER AMP)	

4-10. F-2846 Muting, Jump, Tone Defeat Circuit Board

Conductor Side

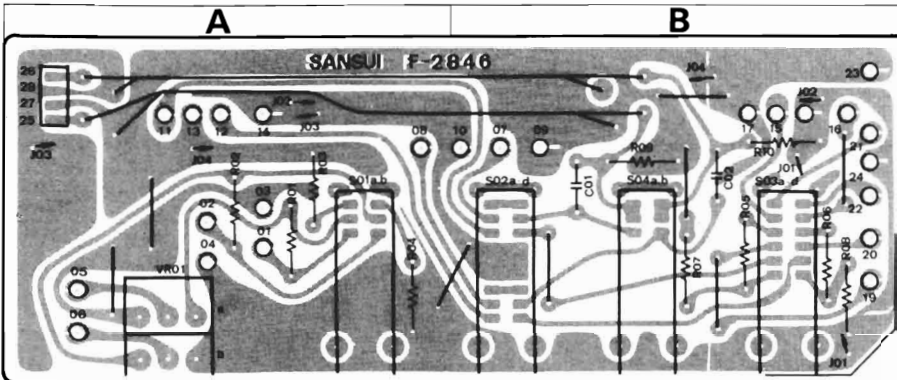

Parts List

Parts No.	Stock No.	Description	Position
C 01, 02	0680061	0.33 μ F 100V	B
C 03, 04	0680017	0.0047 μ F 100V M.C.	
R 01, 02	0280563	56k Ω 1/3W C.R.	A
R 03, 04	0280682	6.8k Ω 1/3W C.R.	A
R 05, 06	0280472	4.7k Ω 1/3W C.R.	B
R 07, 08	0280222	2.2k Ω 1/3W C.R.	B
R 09, 10	0280823	82k Ω 1/3W C.R.	B
R 11, 12	0280100	10 Ω 1/3W C.R.	
VR01	1015170, 1	250k Ω (M.N) Balance Volume	A
S 01	1171130	Lever Switch, Muting	A
S 02	1171170	Lever Switch, Jump	B
S 03	1171150	Lever Switch, Tone Defeat	B
S 04	1171130	Lever Switch, Subsonic Filter	B
	2411570	4P Connector	

4-11. F-2842 Tone Control Circuit Board

Conductor Side

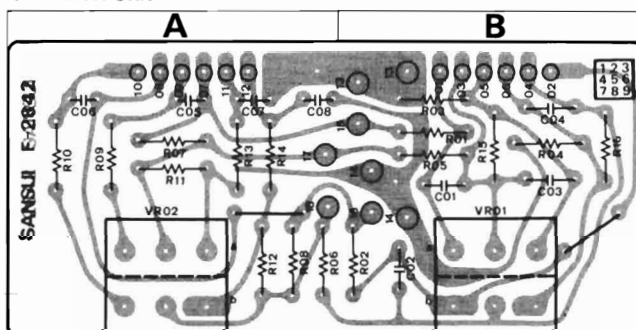

Parts List

Parts No.	Stock No.	Description	Position
C 01, 02	0680051	0.12 μ F 100V N.C.	B
C 03, 04	0680058	0.24 μ F 100V N.C.	B
R 05, 06	0680029	0.015 μ F 100V N.C.	A
C 07, 08	0680039	0.039 μ F 100V N.C.	A
C 09, 10	0622302	3000pF 100V N.C.	
R 01, 02	0280392	3.9k Ω 1/3W C.R.	B
R 03, 04	0280152	1.5k Ω 1/3W C.R.	B
R 05, 06	0280101	100 Ω 1/3W C.R.	B, A
R 09, 10	0280681	680 Ω 1/3W C.R.	A
R 11, 12	0280472	4.7k Ω 1/3W C.R.	A
R 13, 14	0280471	470 Ω 1/3W C.R.	A
R 15, 16	0280822	8.2k Ω 1/3W C.R.	B
VR01, 02	1011170	5k Ω x 2, Tone Control Volume (Bass & Treble)	B, A

4-12. F-2843 Turn-over Circuit Board

Conductor Side

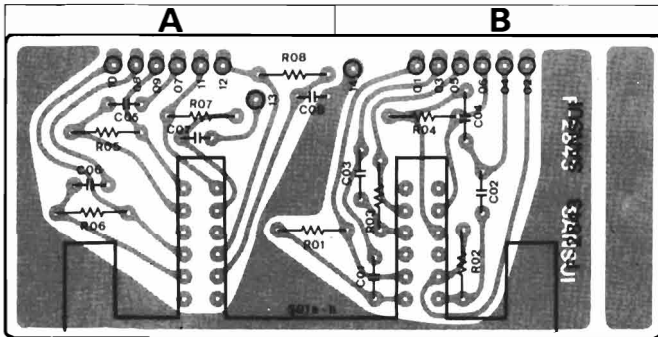

Parts List

Parts No.	Stock No.	Description	Position
C 01, 02	0680051	0.12μF 100V M.C.	B
C 03, 04	0680058	0.24μF 100V M.C.	B
C 05, 06	0680029	0.015μF 100V M.C.	A
C 07, 08	0680038	0.036μF 100V M.C.	A
C 09, 10	0622302	3000pF 125V P.C.	
R 01, 02	0280105	1MΩ 1/3W C.R.	A B
R 03, 04	0280105	1MΩ 1/3W C.R.	B
R 05, 06	0280105	1MΩ 1/3W C.R.	A
R 07, 08	0280105	1MΩ 1/3W C.R.	A
S 01	1131410	Push Switch, Tone Selector	A, B

4-13. F-2928 Rectifier Circuit Board

Conductor Side

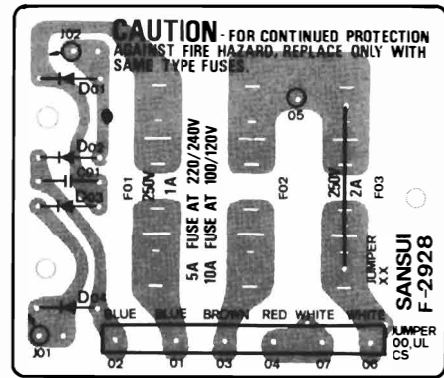

Parts List

Parts No.	Stock No.	Description
•Diodes		
D 01, 02	0310340	10D1
D 03, 04	0310340	10D1
C 01	0606108	0.1μF 250V M.C.
F 01	0431220	1A 250V AC Fuse
F 02	0431320	10A 250V AC Fuse
	0432290	5A 125V AC Fuse
	0434060	10A 250V AC Fuse
F 03	0431240	2A 250V AC Fuse

4-14. F-2836 Tape Playback Circuit Board

Parts List

Parts No.	Stock No.	Description
S 01	1131400	Push Switch, PLAY
	2411570	2.5MMP Connector
	2411590	6P Connector

4-15. F-2837 Tape-copy Switch Circuit Board

Parts List

Parts No.	Stock No.	Description
	1102750	Rotary Switch, Tape-Rec
	2411580	5P Connector

Abbreviations

C.R. : Carbon Resistor	E.C. : Electrolytic Capacitor
S.R. : Solid Resistor	BP.E.C. : Bi-Polar Electrolytic Capacitor
Ce.R. : Cement Resistor	C.C. : Ceramic Capacitor
M.R. : Metal Film Resistor	Mi.C. : Mica Capacitor
F.R. : Fusing Resistor	O.C. : Oil Capacitor
N.I.R. : Non-Inflammable Resistor	P.C. : Polystyrene Capacitor
M.C. : Mylar Capacitor	T.C. : Tantalum Capacitor

5. OTHER PARTS

5-1. Front View



5-2. Top View

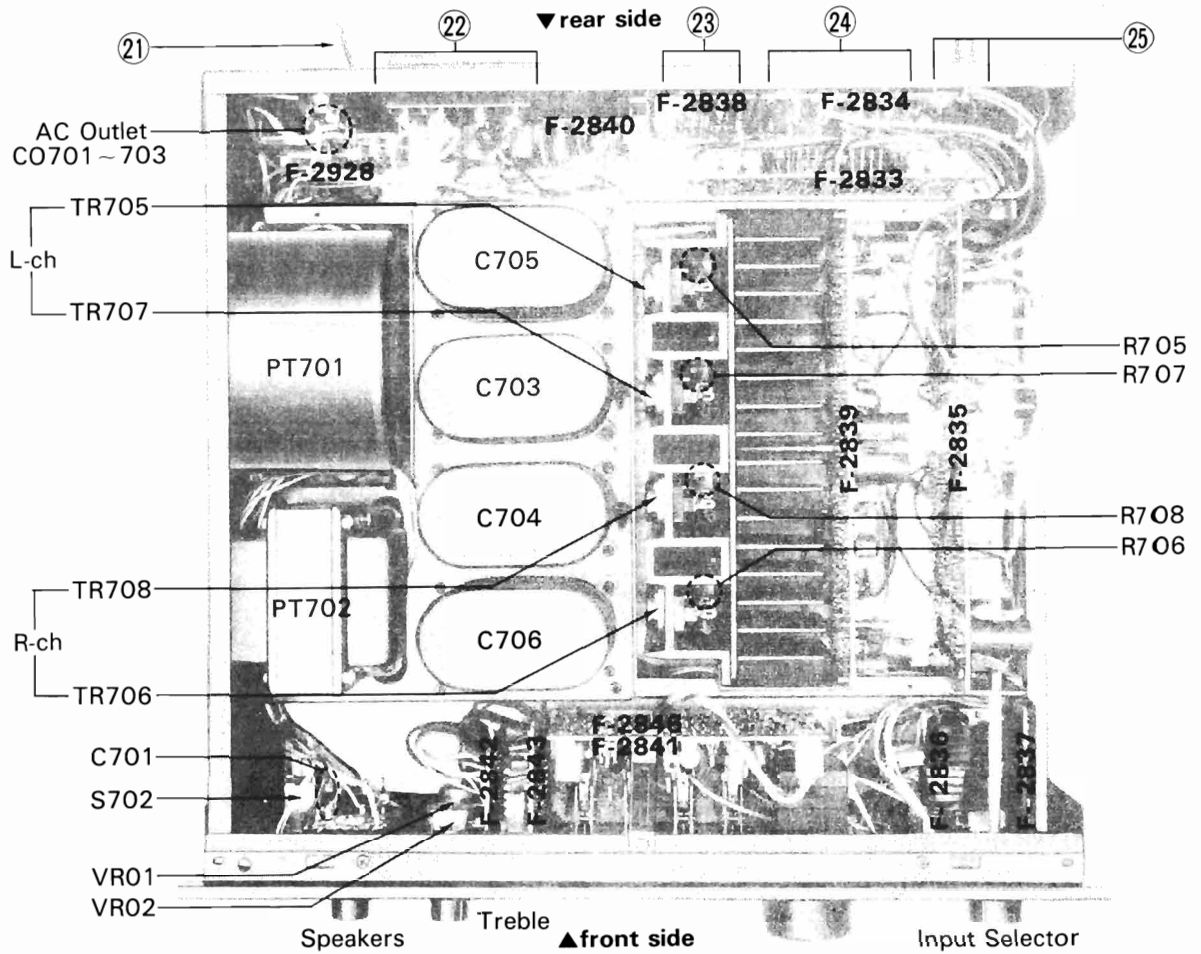

5-3. Bottom View

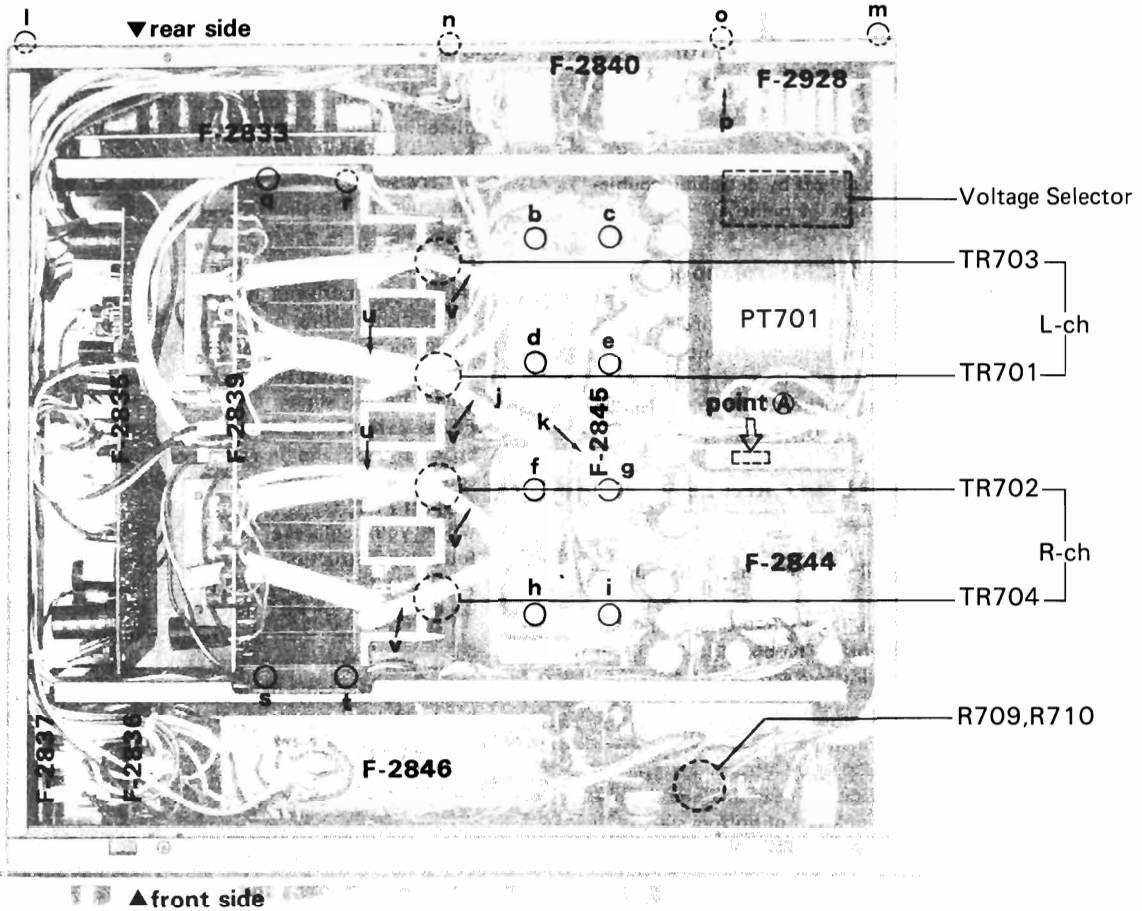

Parts List (Front View)

Parts No.	Stock No.	Description
1	5006780	Bonnet
2	7007961	Front Panel Ass'y (includes Light Emitting Diode, Knob Guide, Push Switch Knob, Sansui Badge)
3	5336600	Sansui Badge
	5318861	Level Volume Knob
4	1090410	100kΩ x 2 Level Volume
5	0319110	Light Emitting Diode
6	5318830	Selector Knob
	1104380	Rotary Switch, Input Selector
	5318840	Tape Copy Knob
7	1102750	Rotary Switch, Tape Copy
	5326620	Push Switch Knob
8	5286721	Knob Guide
	1131400	Push Switch
	5318850	Balance Volume Knob
9	1015170, 1	250kΩ (MN) x 2 Balance Volume
	5326612	Lever Switch Knob
10	1171130	Lever Switch, muting
	5326612	Lever Switch Knob
	1171170	Lever Switch, jump
	5326612	Lever Switch Knob
12	1171130	Lever Switch, subsonic
	5326612	Lever Switch Knob
13	1171150	Lever Switch, tone defeat
	5286721	Knob Guide
14	1131410	Push Switch, turn-over
15	5066390	Bottom Plate
	5318840	Tone Volume Knob
16	1011170	100kΩ (C) x 2, Treble & Bass Volume
17	2430290	Headphone Jack
	5318840	Speaker Selector Knob
18	1101900, 1	Rotary Switch, Speaker
19	5507070	Leg
	5326612	Lever Switch Knob
20	1171630	Lever Switch, Power

Parts List (Top & Bottom View)

Parts No.	Stock No.	Description
21	3800470	Power Cord
	3910600	Strain Relief Bushing
22	2290190	Speaker Terminal
23	2200650	4P Input Terminal (PRE AMP-POWER AMP)
	2200620	4P Input Terminal (TUNER, AUX)
	2200630	4P Input Terminal (PHONO-1, 2)
	2200650	4P Input Terminal (TAPE-1, 2)
25	2230190	Ground Terminal
	2410091	Voltage Selector Plug
	2410830	Voltage Selector Socket
●Transistors		
TR 701, 702	0306710, 1	NMC1012 O, Y
TR 705, 706		
TR 703, 704	0301060, 1	NMA1012 O, Y
TR 707, 708		
C 701	0659801	0.01μF 150V C.C.
C703 ~ 706	0559522	15000μF 63V E.C.
R701 ~ 708	0159130	0.33Ω 5W C.R.
R 709, 710	0202221	220Ω 2W N.I.R.
CO701 ~ 703	2450070	AC Outlet
S 702	1171600	Power Switch
PT 701	4002840	Power Transformer
PT 702	4002830	Power Transformer

6. REPLACEMENTS & REPAIR NOTES

6-1. Power Supply Circuit Board, F-2844 for pre-amp section (refer to pictures on page 9, 10)

- 1) Remove bottom plate 15
- 2) Take off a screw for installing F-2844
- 3) The circuit board, F-2844 can be easily off by detaching double-faced adhesive tape just on the back of point (A).

2. Power Supply Circuit Board, F-2845 for power amp section

- 1) Take off 8 screws (b, c, d, e, f, g, h, i) fixing the taps of electrolytic capacitors of C705, C703, C704, C706 with the circuit board.
- 2) Disconnect a grey wire soldered only on GND lag, (j).
- 3) Plug out two orange wires from plug socket, "k", on the circuit board.

3. Protector Circuit Board, F-2840 and Rectifier Circuit Board, F-2928

- 1) Remove bottom plate first.
- 2) Take off 5 screws (l, m) for installing the rear panel and the panel will be easily off.
- 3) Then take off 4 screws (n, o) installing F-2840 board, and the F-2840 with F-2928 board can be off, (The board, F-2840, can be separated from F-2928 by removing two screws, (p).)

4. Power transistors

- 1) Remove bottom plate.
- 2) Take 4 screws (q, r, s, t) off for installing heat sink and disconnect wires (u, v), then pull the heat sink out of bottom side.

6-2. Repair notes

- 1) Turn level volume down or power switch off, when inserting or disconnecting shielded cable with plug into/out of input terminals on rear panel of AU-919.
Otherwise, power driver transistor (s) or speaker would be defective due to clicks occurred by the contact inside the female plug.
 - 2) If you replace the defective power transistor (s), check all other transistors on driver amp circuit board, F-2839.
 - 3) When dismounting heat sink, check or repair of equalizer amp circuit board, F-2835 can be made, as the circuit board is holded with heat sink together by two screws.
 - 4) There are six kinds of ranks (K2, L1, L2, M1, M2, N) of both FETs, 2SK163 and 2SJ44 respectively on MC head amp circuit board, F-2833, and the circuitry on the board is parallel-connected complementary arrangement using PNP (2SK163) and NPN type (2SJ44) FET.
When you replace either 2SK163 or 2SJ44, please note the following instructions referring to the list on page 3
 1. Use same rank of all FETs on one channel.
 2. Each rank of FET determines the total gain in quantity per one channel, therefore, total quantity of FET on one channel is dependent upon the rank, due to slightly different gm. even in the same name FET.
- * As to total quantities of 2SK163 and 2SJ44 per one channel, refer to the list on page 3.

7. NOTES / When using external system selector for switching audio components—receivers, amplifiers, decks and loudspeakers, etc.

Please consider the following notes when using the external system selector with this AU-919 having wide-spread frequency range extended to 500 kHz and high slew rate, 200V/ μ sec.

- 1) To avoid hum-noise, blow of power or driver transistors, connect firmly an earth wire between turntable, the external system selector and this AU-919.

- 2) Do not connect earth wire commonly between outer shielded side (GND) of pin cord (or outer side of female pin plug of input terminal of AU-919) and GND terminal(s) of the system selector.
- 3) After the above connection, confirm that oscillation noise or annoying noise dose not come from loudspeakers, if possible, that additionally it does not make oscillation through wide bandwidth 10 MHz or more oscilloscope.

• Design and specifications subject to change without notice for improvement.
 • La présentation et les spécifications sont susceptibles d'être modifiées sans préavis par suites d'améliorations éventuelles.
 • Änderungen, die dem technischen Fortschritt dienen, bleiben vorbehalten.

8. SCHEMATIC DIAGRAM /8-1. Pre/Main Section

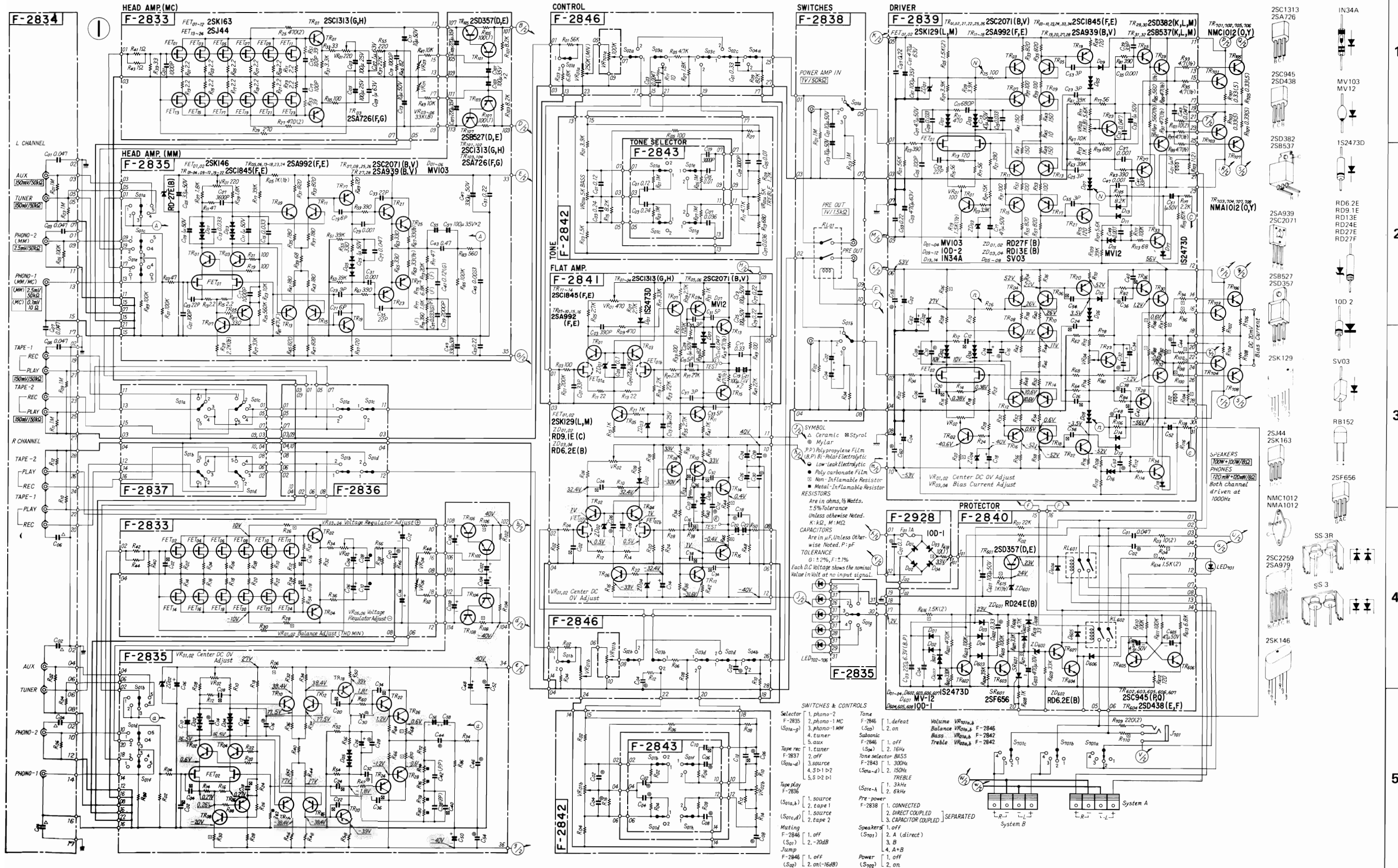

• Design and specifications subject to change without notice for improvement.
 • La présentation et les spécifications sont susceptibles d'être modifiées sans préavis par suites d'améliorations éventuelles.
 • Änderungen, die dem technischen Fortschritt dienen, bleiben vorbehalten.

AU-919 AU-919

8-2. Power Supply Section

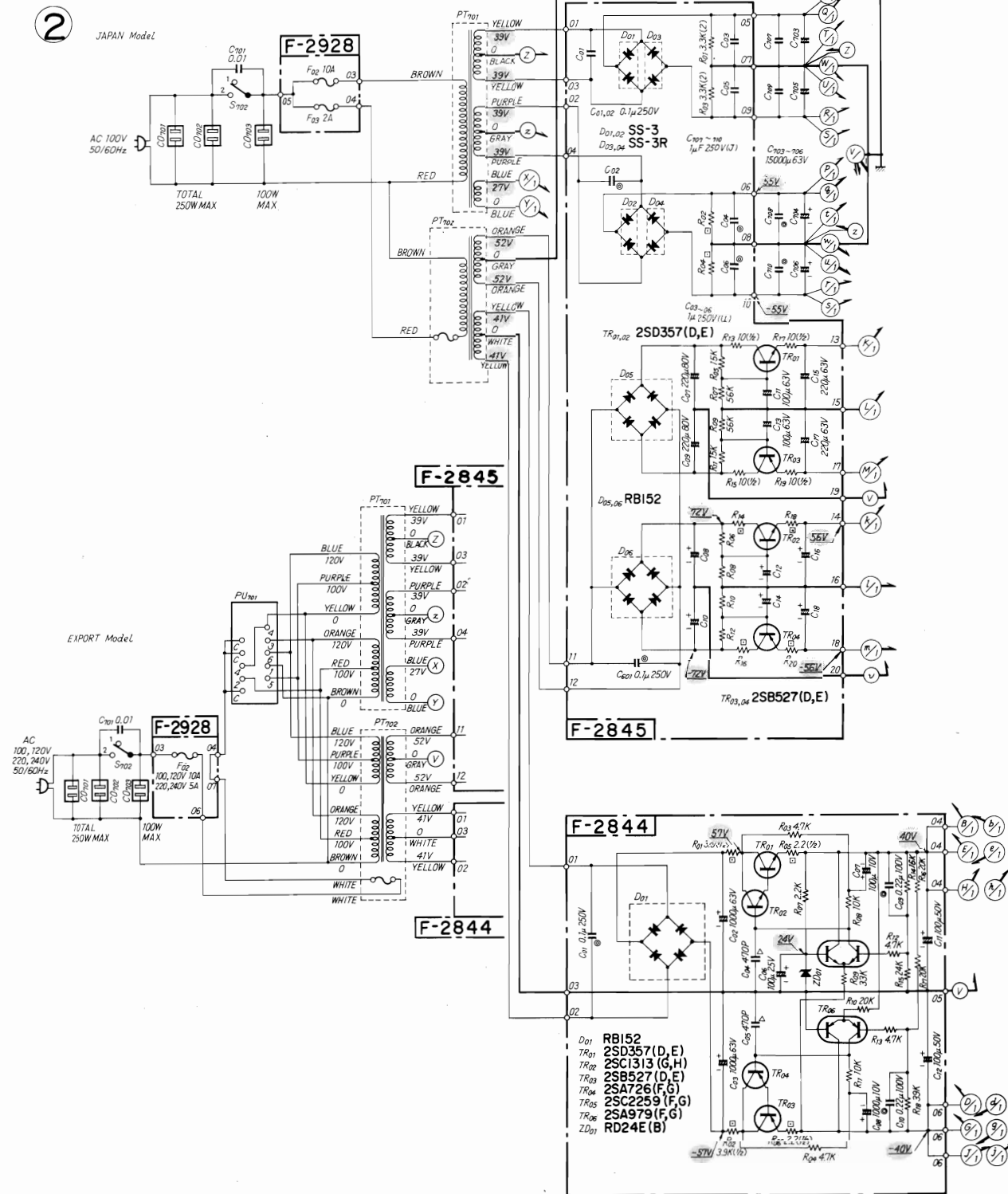

9. PACKING LIST

Parts No.	Stock No.	Description
1	9116770	Vinyl Cover
2	9028250	Stylofoam Packing (R)
3	9028240	Stylofoam Packing (L)
4	9001020	Carton Case
5	5996080	Curly Stopper

10. ACCESSORY PARTS LIST

Stock No.	Description
9203900	Operating Instructions
5396340	Rack-mounting Adaptor (ea.)
9237850	Schematic Diagram

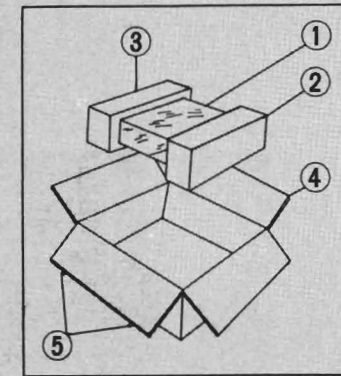

MEMO



SANSUI ELECTRONICS CORPORATION: 55-11 Queens Blvd. Woodside, N.Y. 11377 U.S.A.
 333 West Alondra Blvd. Gardena, California 90247 U.S.A.
 3036 Koapaka St. Honolulu, Hawaii 96819 U.S.A.

SANSUI AUDIO EUROPE N.V.: North Trade Bldg (9th floor) Noorderlaan 133-Bus 1,2030 Antwerp, Belgium
 SANSUI AUDIO EUROPE S.A.: Arabella center, 6 Frankfurt AM Main, Lyoner Strasse 44-48, West Germany

SANSUI ELECTRIC COMPANY LTD.: 14-1, Izumi 2-chome, Suginamiku, Tokyo 168 Japan PHONE: (03) 323-1111/TELEX:232-2076