

SERVICE MANUAL

SOLID-STATE AM/FM STEREO TUNER AMPLIFIER

SANSUI 2000A

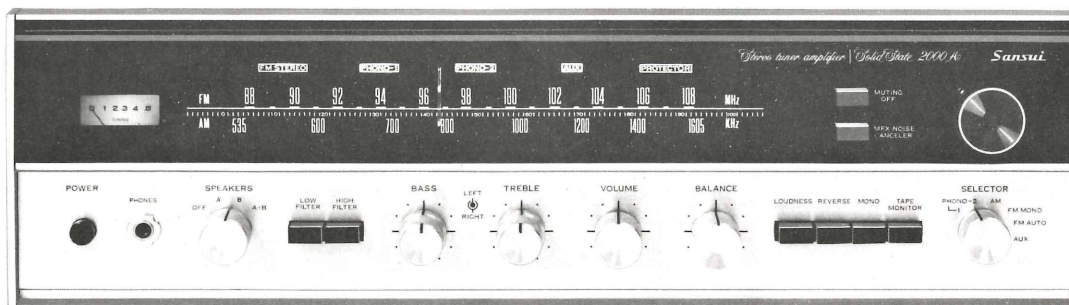

sansui

SANSUI ELECTRIC COMPANY LIMITED

CONTENTS

GENERAL TROUBLESHOOTING CHART.....	3, 4
CUSTOM MOUNTING	5, 6
DISASSEMBLY PROCEDURE	7
BLOCK DIAGRAM.....	8
ALIGNMENT	
—TEST POINTS.....	9, 10
—FM ALIGNMENT PROCEDURE	11
—FM MULTIPLEX ALIGNMENT PROCEDURE	12
—AM ALIGNMENT PRCCEDURE	13
—CURRENT ADJUSTMENT	
—OUTPUT ADJUSTMENT	14
PRINTED CIRCUIT SHEETS AND PARTS LIST	
.....	15, 16, 17, 18, 19, 20, 21, 22, 23, 24, 25, 26, 27, 28
OTHER PARTS AND THEIR POSITION ON CHASSIS	
.....	29, 30

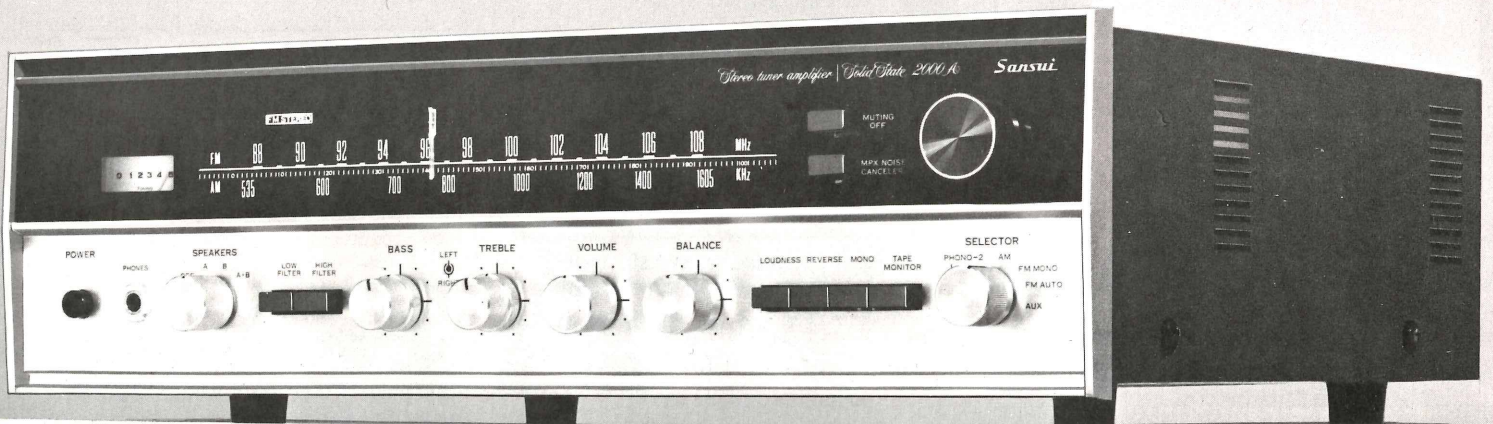

GENERAL TROUBLESHOOTING CHART

If the amplifier is otherwise operating satisfactorily, the more common causes of trouble may generally be attributed to the following:

1. Incorrect connections or loose terminal contacts. Check the speakers, record player, tape recorder, antenna and line cord.
2. Improper operation. Before operating any audio com-

- ponent, be sure to read the manufacturer's instructions.
 3. Improper location of audio components. The proper positioning of components, such as speakers and turntable, is vital to stereo.
 4. Defective audio components.
- The following are some other common causes of malfunction and what to do about them:

PROGRAM	SYMPTOM	PROBABLE CAUSE	WHAT TO DO
AM, FM or MPX reception	A. Constant or intermittent noise heard at times or in a certain area	<ul style="list-style-type: none"> * Discharge or oscillation caused by electrical appliances, such as fluorescent lamp, TV set, D.C. motor, rectifier or oscillator * Natural phenomena, such as atmospherics, statics or thunderbolts * Insufficient antenna input due to ferroconcrete wall or long distance from the station * Wave interference from other electrical appliances 	<ul style="list-style-type: none"> * Attach a noise limiter to the electrical appliance causing the noise, or attach it to the amplifier's power source * Install an outdoor antenna and ground the amplifier to raise the signal-to-noise ratio * Reverse the power cord plug-receptacle connections * If the noise occurs at a certain frequency, attach a wave trap to the ANT. input * Keep the set at a proper distance from other electrical appliances
	B. The needle of the tuning meter does not move sharply	<ul style="list-style-type: none"> * Receiver is located in a weak signal area 	<ul style="list-style-type: none"> * Place the set to receive maximum signal strength
	C. The zero point of the meter diverges much	<ul style="list-style-type: none"> * Regional difference in field intensity. 	<ul style="list-style-type: none"> * The unit is not at fault
AM reception	A. Noise heard at a particular time of a day, in a certain area or over part of dial	<ul style="list-style-type: none"> * Due to the nature of AM broadcasts 	<ul style="list-style-type: none"> * Install the antenna for maximum antenna efficiency. See "ANTENNA" in the operating instructions * In some cases, the noise can be eliminated by grounding the amplifier or reversing the power cord plug-receptacle connections
	B. High-frequency noise	<ul style="list-style-type: none"> * Adjacent-channel interference or beat interference * TV set too close to audio system 	<ul style="list-style-type: none"> * Although such noise cannot be eliminated by the amplifier, it is advisable to adjust the TREBLE control from midpoint to left and switch on the HIGH FILTER * Keep the TV set at a proper distance from the audio system
FM reception	A. Noisy	<ul style="list-style-type: none"> * Poor noise limiter effect or too low S/N ratio due to insufficient antenna input 	<ul style="list-style-type: none"> * Install the antenna (supplied) for maximum signal strength * If this does not prove effective, use an outdoor antenna designed exclusively for FM. When you use a TV antenna for both TV and FM with a splitter, make sure TV reception is not affected * An excessively long antenna may cause noise
	<p>Note: FM reception is affected considerably by transmission conditions of stations: power and antenna efficiency. As a result, you may receive one station quite well while receiving another station poorly</p>		

PROGRAM	SYMPTOM	PROBABLE CAUSE	WHAT TO DO
FM reception (cont'd)	B. A series of pops is heard	* Ignition noise caused by an automobile engine	* Install the antenna and its lead-in wire in proper distance from the road or raise the antenna input as described above
	C. Tuning noise between stations	* This results from the nature of the FM reception. As the station signal becomes weak, the noise limiter effect is decreased, and the amplification of the limiter, in turn, is enlarged, generating a noise	* Turn the MUTING switch on. It reduces the sensitivity, and therefore it should be used sparingly
FM-MPX reception	A. Noise heard during FM-MPX reception while not heard during FM mono reception	* Weaker signal because the service area of the FM-MPX broadcast is only half that of the FM mono broadcast	* Install the antenna for maximum antenna input * Switch on the HIGH FILTER and/or turn the TREBLE control from midpoint, left
	B. Clearness of channel separation is decreased during reception	* Excess heat	* Circulation of air is important to the amplifier. Be sure that air is flowing under the amplifier
	C. The stereo indicator blinks on and off	* Interference	* The indicator is not at fault. Adjust VR ₄₀₁
	D. The stereo indicator blinks on and off even though stereo station is not received	* Interference	* The indicator is not at fault. Adjust VR ₄₀₁
Record playing or tape playback	A. Hum or howling	* Record player placed directly on speaker * Wire other than shielded wire used * Loose terminal contact * Shielded wire too close to line cord, fluorescent lamp or other electrical appliances * Nearby amateur radio station or TV transmission antenna	* Place a cushion between the player and the speaker box or place them away from each other * The connecting shielded wire should be as short as possible * Switch on the LOW FILTER and turn the BASS control from midpoint to left * Consult the nearest Radio Regulatory Bureau
	B. Surface noise	* Worn or old record * Worn stylus * Stylus dusty * Improper stylus pressure * Worn playback head	* Switch on the HIGH FILTER and turn the TREBLE control from midpoint to left * Clean or replace the stylus * Replace the playback head.
All stereo programs	BALANCE control is not at midpoint when equal sound comes from left and right channels	* It is important to adjust for equal sound from both channels. It should not always be set to the midpoint	* Set the MONO switch to MONO and then set the BALANCE control to a position where equal sound comes from both channels

CUSTOM MOUNTING

How to install the amplifier in a wooden cabinet

1. Make a cabinet window of 432mm or 17" in width and 117mm or $4\frac{39}{64}$ " in height.
2. Place two square pieces of wood ($20 \times 20 \times 240$ mm or $\frac{25}{32} \times \frac{25}{32} \times 9\frac{29}{64}$ ") for supporting the amplifier in the bottom board of the cabinet.
3. Cut two holes for attachment bolts in the bottom board of the cabinet.
4. Remove the four rubber feet and two screws from the amplifier.
5. Place the amplifier in position through the cabinet window.
6. Make sure the amplifier is in position, then put the washers in butterfly bolts (supplied) and fix the amplifier to the cabinet with butterfly bolts.

NOTE:

When the amplifier is built into the cabinet, four rubber feet and two screws are not used. Retain them for future use.

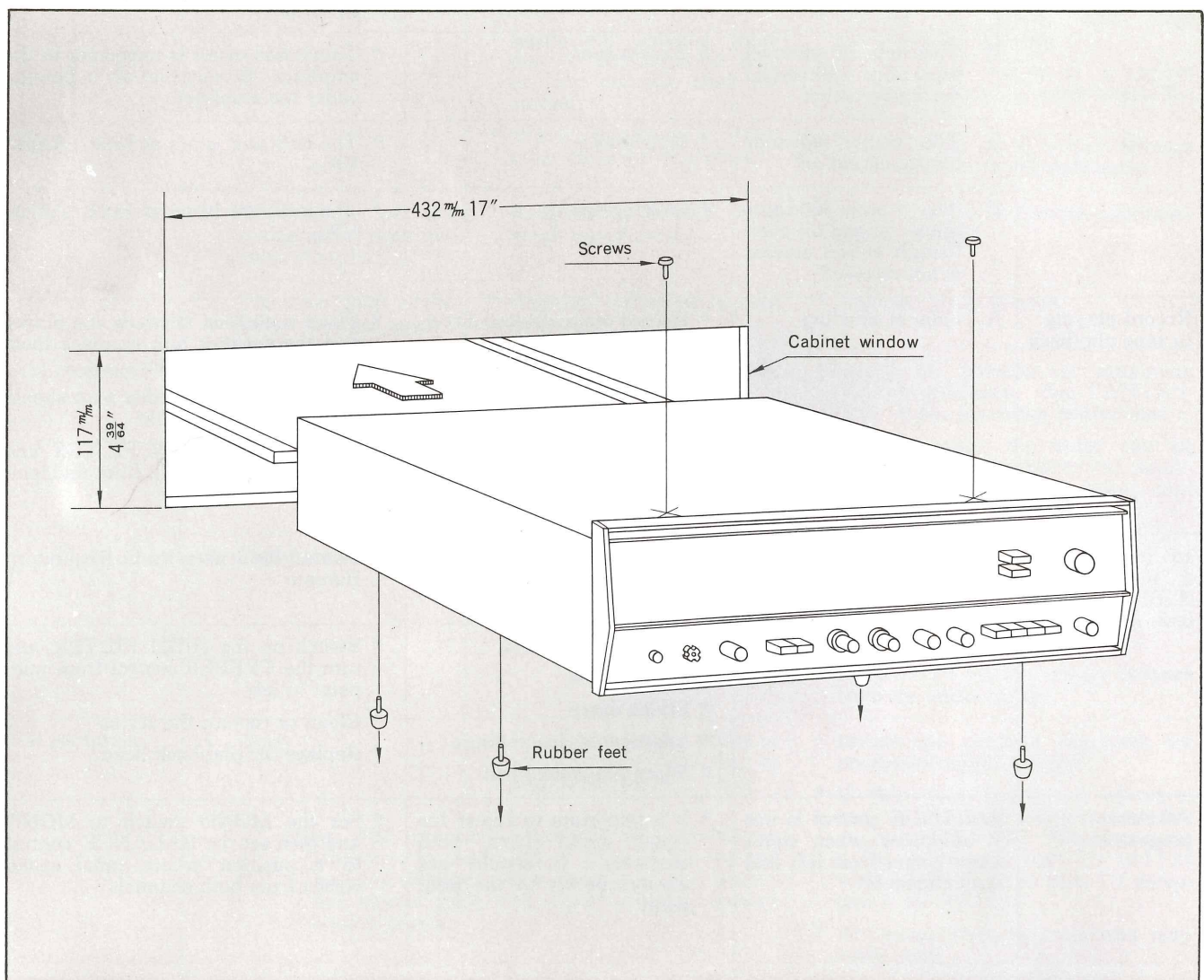

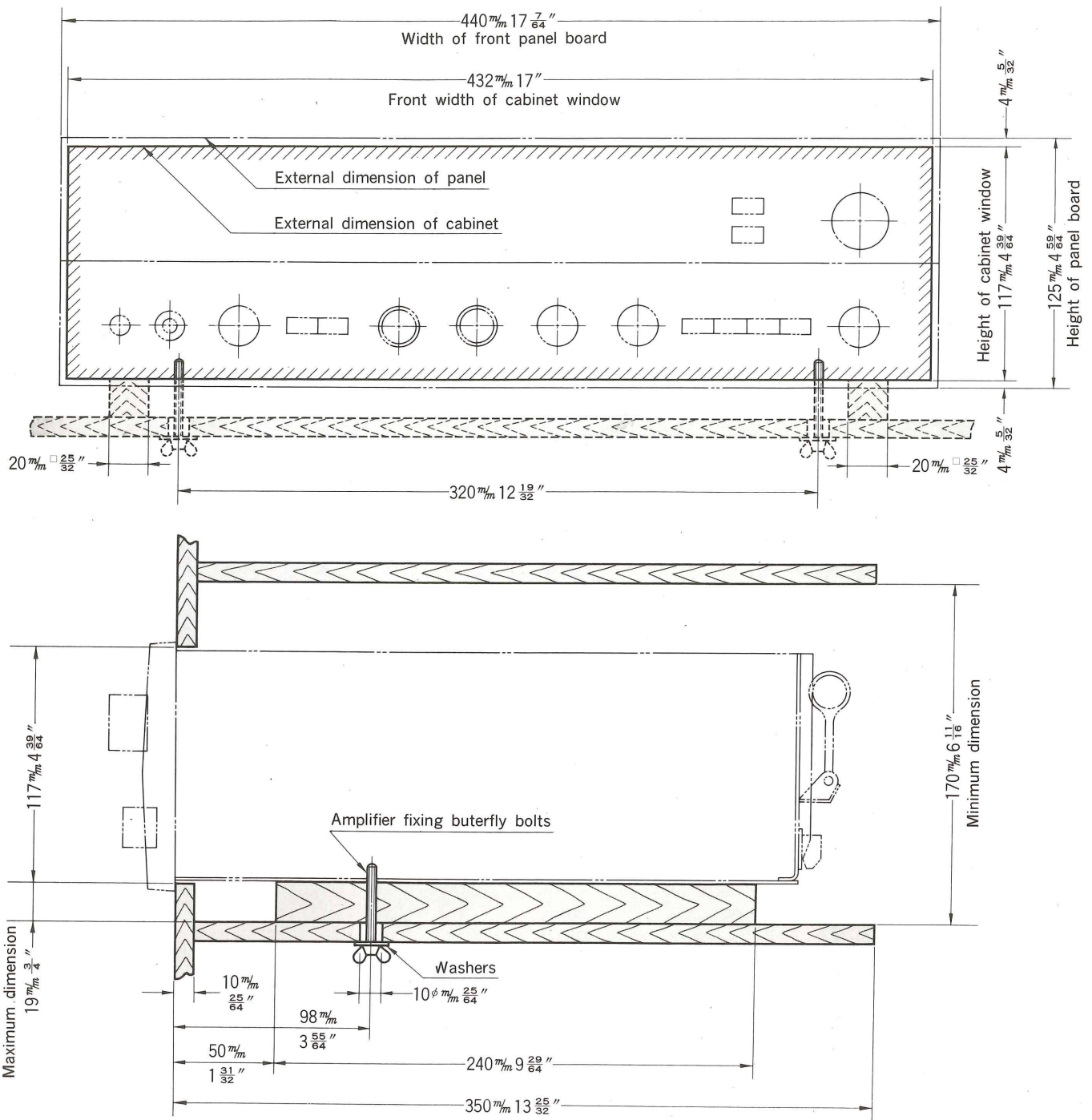

DISASSEMBLY PROCEDURE

REMOVING THE FRONT PANEL, BONNET AND BOTTOM PLATE

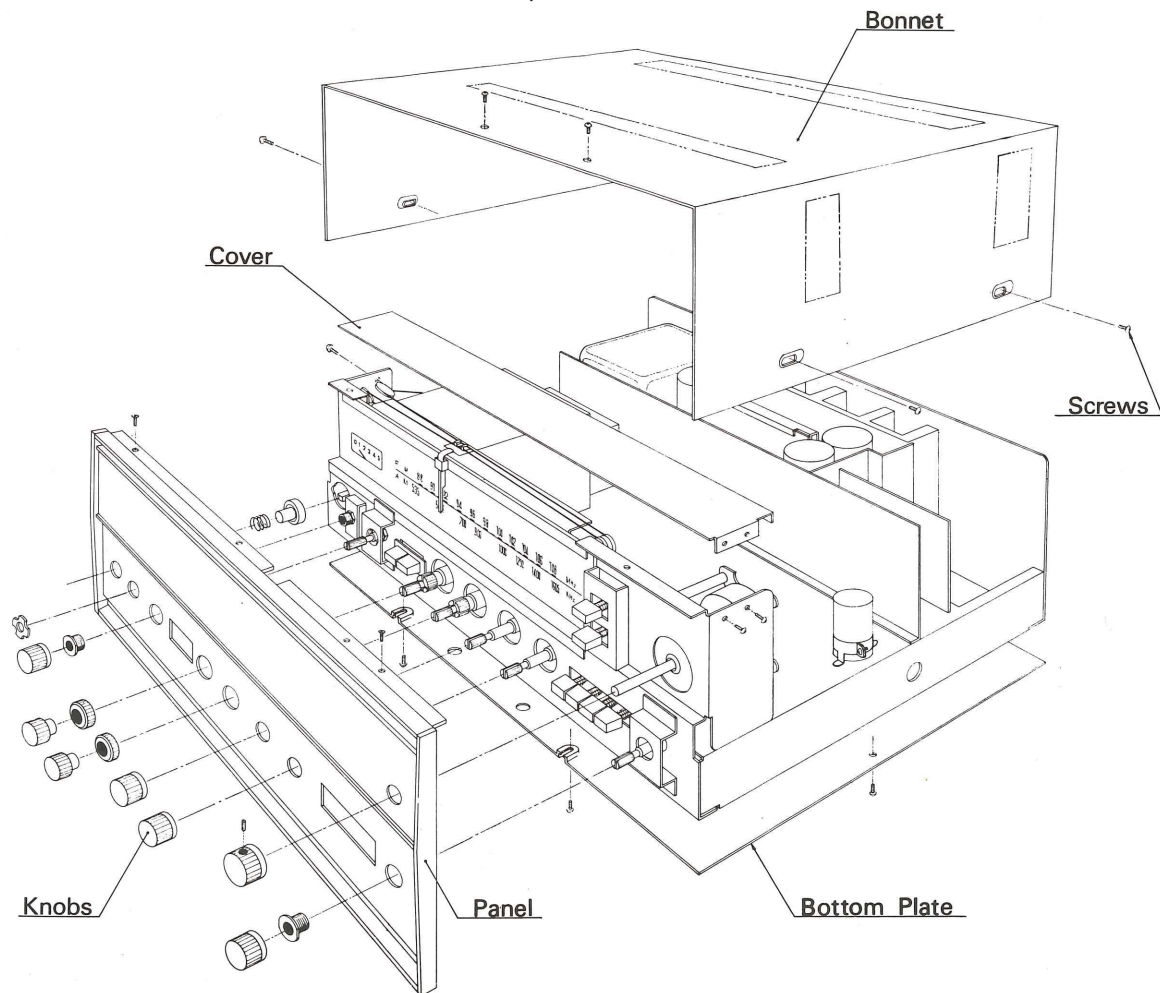

DIAL MECHANISM

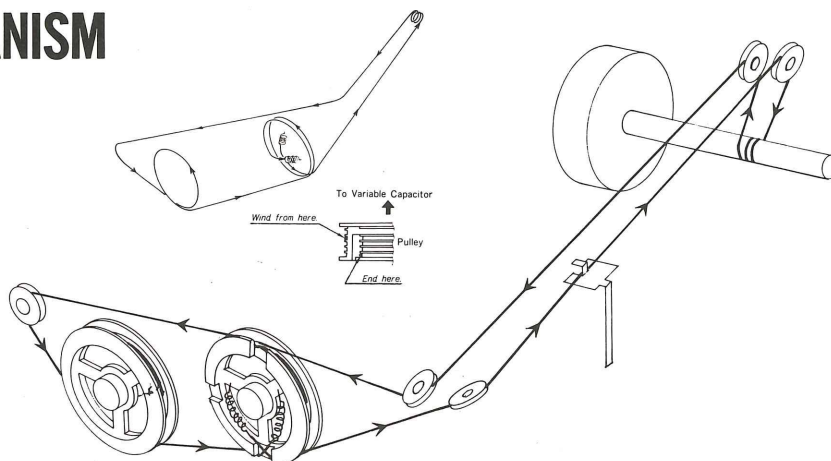

BLOCK DIAGRAM

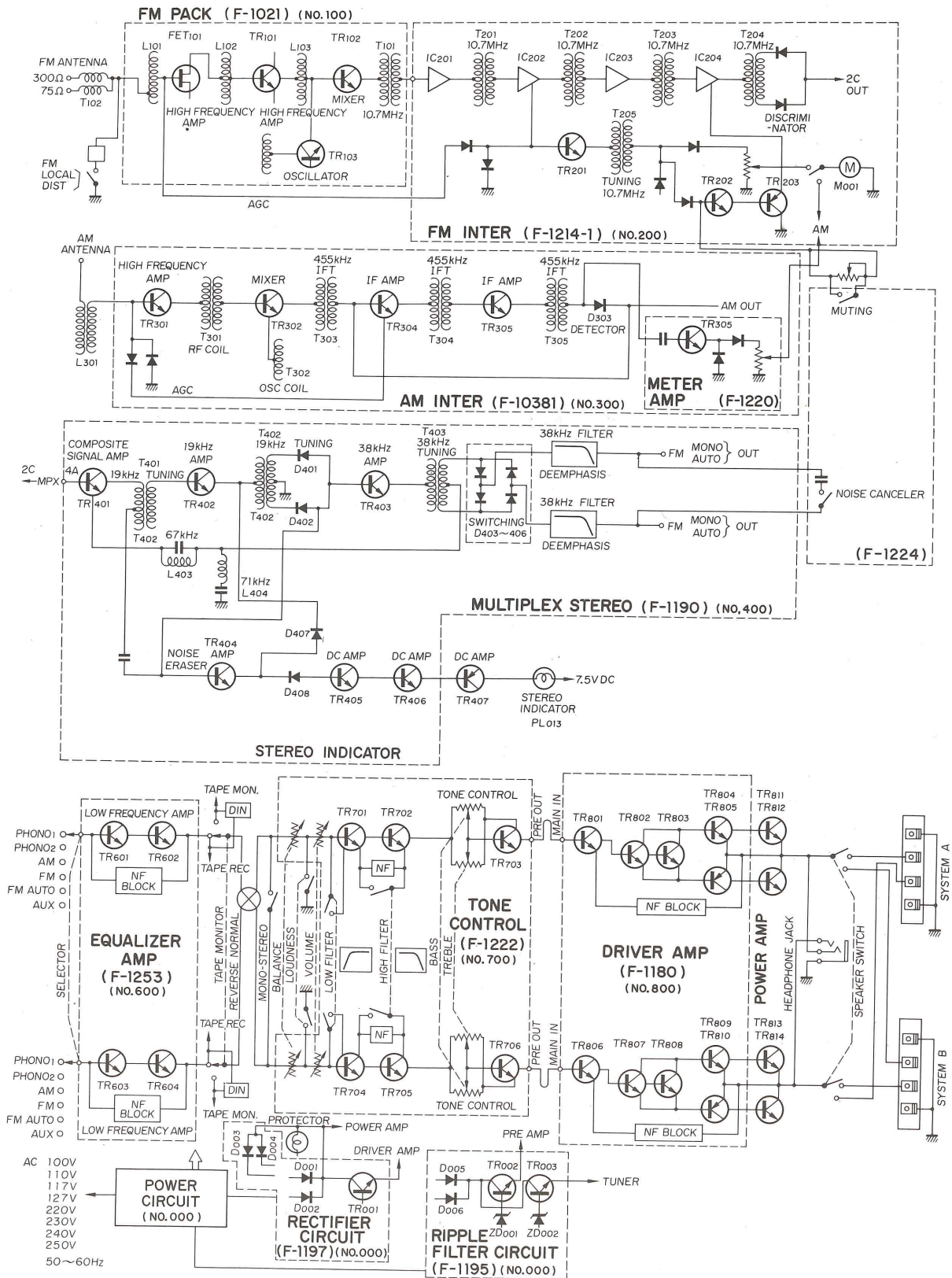

ALIGNMENT

TEST POINTS

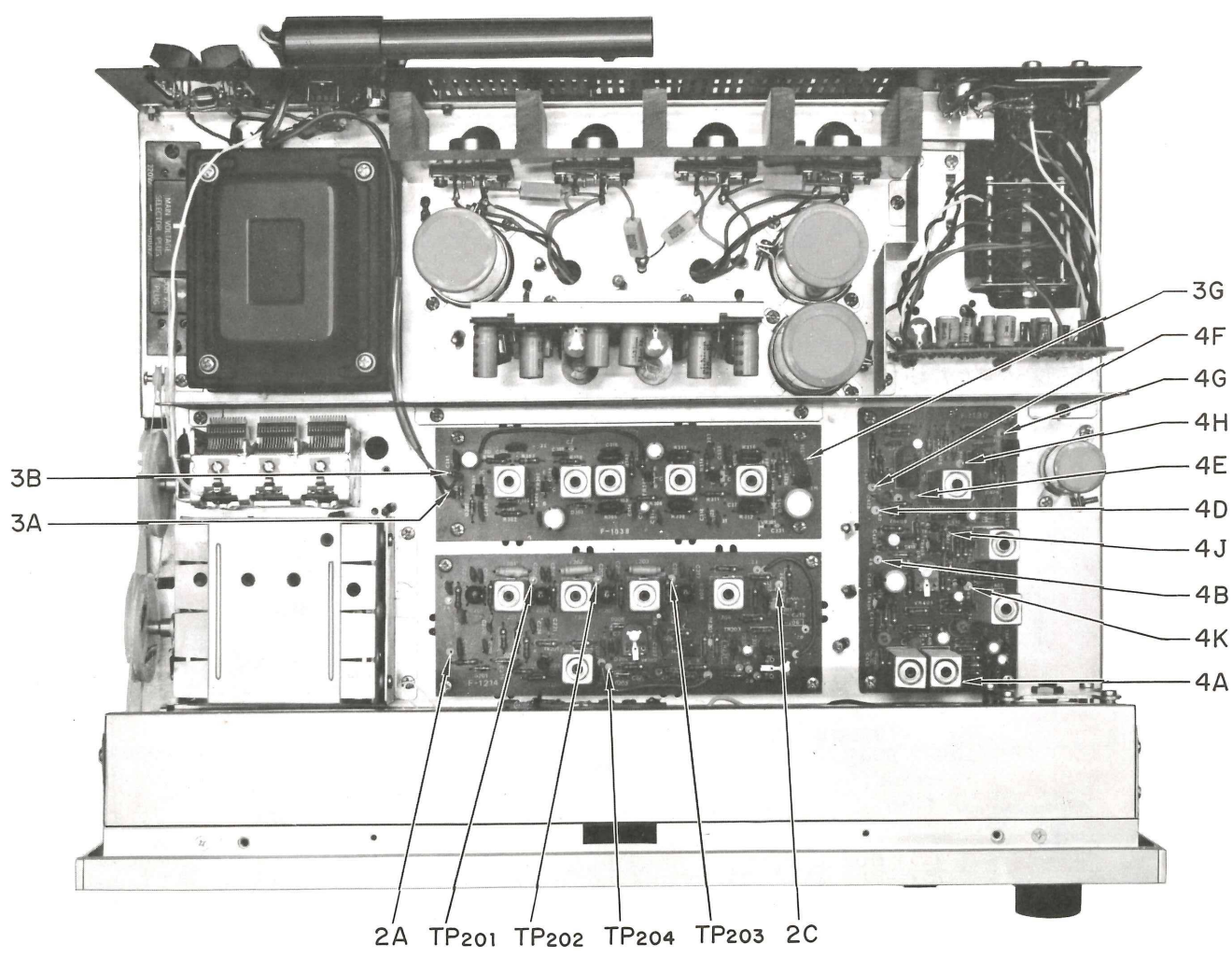

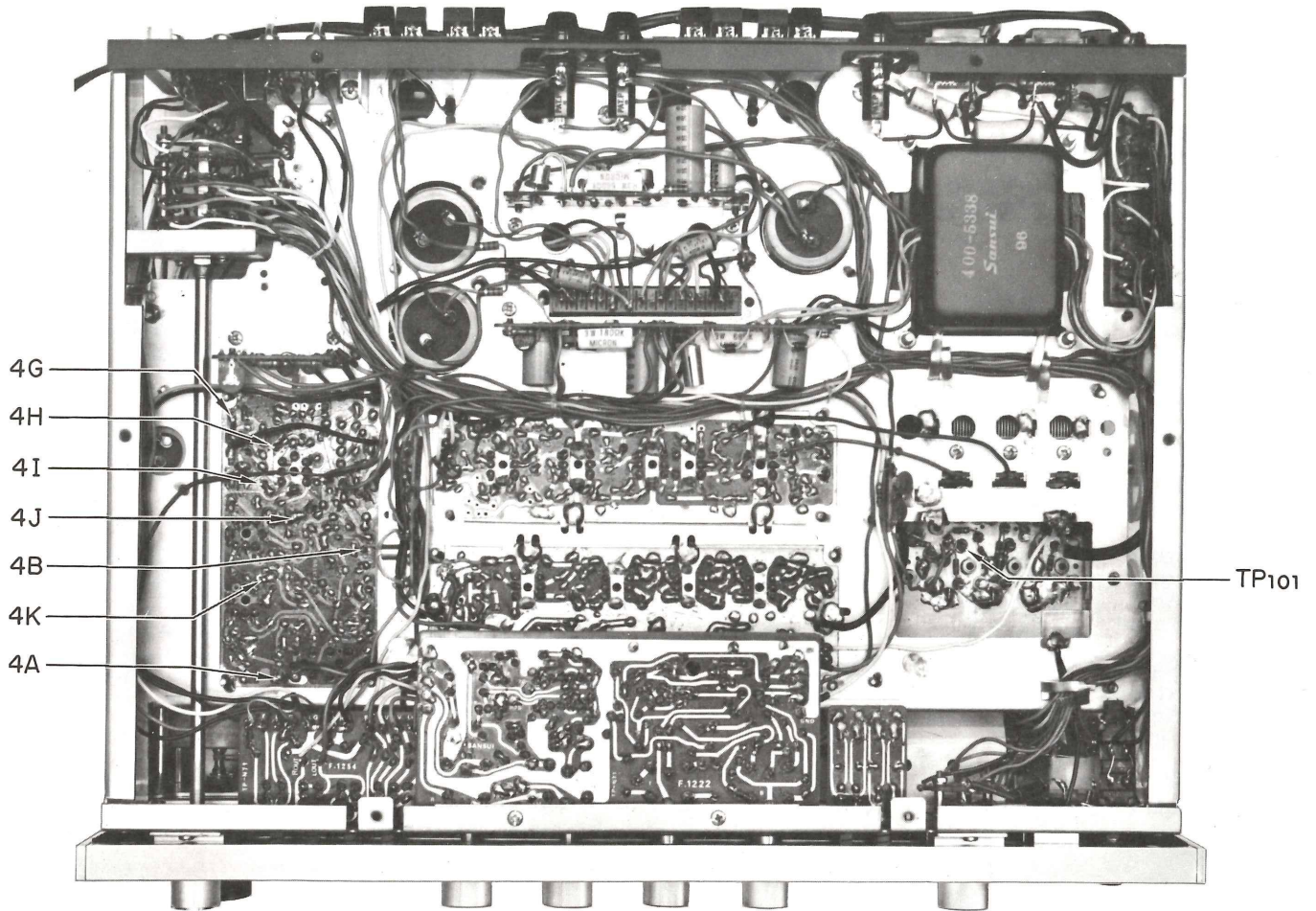

ALIGNMENT

FM ALIGNMENT PROCEDURE

NOTE: To align, set the signal generator level to minimum.
Turn tuning gang fully.
Center carrier wave.
Set pointer at reference mark.

STEP	ALIGN	GENERATOR	FEED SIGNAL	CONNECT	DIAL SETTING	ADJUST	ADJUST FOR
1.	IF Transformer	10.7 MHz ±200 kHz	Sweep signal to TP ₁₀₁ via the 10pF ceramic condenser	Oscilloscope to TP _{201, 202} and ₂₀₃ via the 10μF ceramic condenser with probe		Top and bottom sides of T _{202, 203}	Best I.F.T. wave form
2.	Discriminator	10.7 MHz ±200 kHz	Sweep signal to TP ₁₀₁ via the 10pF ceramic condenser	Oscilloscope to 2C		FM. Discriminator transformer T ₂₀₄ top and bottom sides	S curve
3.	O.S.C	90 MHz 400 Hz 100% Modulation	To antenna terminals	Oscilloscope and V.T.V.M. to output load	90 MHz	O.S.C. coil L ₁₀₄	Maximum
4.	O.S.C	106 MHz 400 Hz 100% Modulation	To antenna terminals	Oscilloscope and V.T.V.M. to output load	106 MHz	O.S.C. trimmer TC ₁₀₅	Maximum
5.	Reiterate 3 and 4.						
6.	High-frequency Amp. Circuit	90 MHz 400 Hz 100% Modulation	To antenna terminals	Oscilloscope and V.T.V.M. to output load	90 MHz	Antenna coil L _{101, L102} and L ₁₀₃	Maximum
7.	High-frequency Amp. Circuit	106 MHz 400 Hz 100% Modulation	To antenna terminals	Oscilloscope and V.T.V.M. to output load	106 MHz	Trimmer TC _{101, TC103} and TC ₁₀₄	Maximum
8.	Reiterate 6 and 7.						

FM IF WAVE FORM

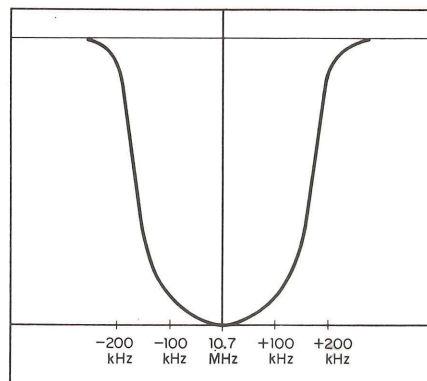

FM DISCRIMINATOR WAVE FORM

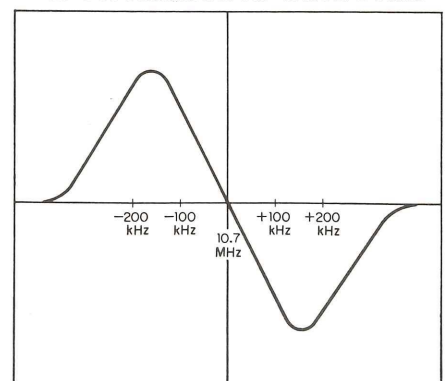

FM MULTIPLEX ALIGNMENT PROCEDURE

1. Do not attempt to align the Multiplex Circuit unless the following equipments are available:

- a. Multiplex Stereo Generator b. Oscilloscope c. AC. V.T.V.M. d. Audio Oscillator e. FM Signal Generator

STEP	ALIGN	GENERATOR	FEED SIGNAL TO	TEST EQUIPMENT (S)	ADJUST	ADJUST FOR
1.	67 kHz Trap	67 kHz Audio Signal	TP _{4A} or 2C	V.T.V.M. at 4 _I	L ₄₀₃	Minimum
2.	71 kHz Trap	71 kHz Audio Signal	TP _{4A} or 2C	V.T.V.M. at 4 _I	L ₄₀₄	Minimum
3.	19 kHz Transformer	FM Signal Gen. Modulated 30% by STEREO Gen. sub-channel	Antenna terminals Tune to signal	V.T.V.M. and Oscilloscope at 4 _K	T ₄₀₁	Maximum
4.	19 kHz Transformer	FM Signal Gen. Modulated 30% by STEREO Gen. sub-channel	Antenna terminals Tune to signal	V.T.V.M. and Oscilloscope at 4 _J	T ₄₀₂	Maximum
5.	38 kHz Transformer	FM Signal Gen. Modulated 30% by STEREO Gen. sub-channel	Antenna terminals Tune to signal	V.T.V.M. and Oscilloscope at 4 _H	T ₄₀₃	Maximum
6.	38 kHz Transformer and Separation VR	FM Signal Gen. Modulated 30% by STEREO Signal Gen, channel-L	Antenna terminals Tune to signal	V.T.V.M. and Oscilloscope at output load, (channel-R)	T ₄₀₂ or T ₄₀₃ within 1/4 turn and Separation VR(VR ₆₀₁)	Minimum, (Channel-R)

ALIGNMENT

AM ALIGNMENT PROCEDURE

NOTE: To align, set the signal generator level to minimum.

STEP	ALIGN	GENERATOR	FEED SIGNAL TO	TEST EQUIPMENTS	DIAL SETTING	ADJUST	ADJUST FOR
1.	I.F. Transformer	455 kHz ± 30 kHz Sweep-generator	Antenna terminals	Oscilloscope and V.T.V.M. at 3G		Top and bottom sides from the 1st I.F.T. (T ₃₀₃) to the 3rd I.F.T. (T ₃₀₅)	Best I.F.T. wave form
2.	O.S.C.	AM-generator 535 kHz 400 Hz 30% Modulation	Antenna terminals	Oscilloscope and V.T.V.M. at output load	535 kHz	O.S.C. Coil T ₃₀₂	Maximum
3.	O.S.C.	AM-generator 1600 kHz 400 Hz 30% Modulation	Antenna terminals	Oscilloscope and V.T.V.M. at output load	1600 kHz	O.S.C. Trimmer TC ₃₀₃	Maximum
4.	Reiterate 2 and 3						
5.	RF amp.	AM-generator 600 kHz 400 Hz 30% Modulation	Antenna terminals	Oscilloscope and V.T.V.M. at output load	600 kHz	RF transformer T ₃₀₁	Maximum
6.	Antenna circuit	AM-generator 600 kHz 400 Hz 30% Modulation	Antenna terminals	Oscilloscope and V.T.V.M. at output load	600 kHz	Ferrite bar Antenna T ₃₀₆	Maximum
7.	RF amp.	AM-generator 1400 kHz 400 Hz 30% Modulation	Antenna terminals	Oscilloscope and V.T.V.M. at output load	1400 kHz	RF Trimmer TC ₃₀₂	Maximum
8.	Antenna circuit	AM-generator 1400 kHz 400 Hz 30% Modulation	Antenna terminals	Oscilloscope and V.T.V.M. at output load	1400 kHz	Antenna circuit Trimmer TC ₃₀₁	Maximum
9.	Reiterate 5. 6. 7. 8.						

AM IF WAVE FORM

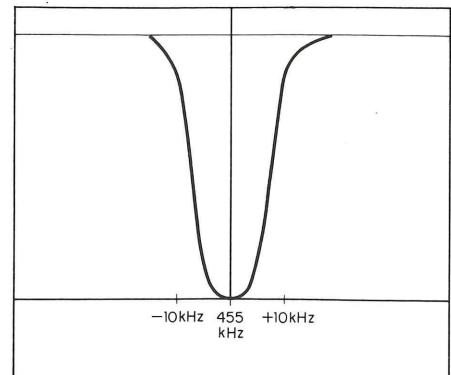

1. CURRENT ADJUSTMENT

STEP	SETTING OF AMMETER (TESTER)	WHAT TO DO	NOTE
1.		Remove F ₈₀₁ and F ₈₀₂	Use an ammeter having 100 or 50mA range.
2.		Set VR ₈₀₂ and VR ₈₀₄ to minimum.	
3.		Set VR ₇₀₂ and VR ₇₀₆ (VOLUME) to minimum.	
4.		Push the POWER switch ON.	Be sure to switch on 1st and then connect the ammeter.
5.	100mA range.	Connect the ammeter to F ₈₀₁ as illustrated in Fig. 1.	
6.		Turn VR ₈₀₂ clockwise and adjust current to 15 to 10mA at room temperature of 25°C or less or to 20 to 15mA at 25°C or more.	
7.	100mA range.	Push the POWER switch OFF and attach F ₈₀₁ in place.	
8.		Push the POWER switch ON and connect the ammeter to F ₈₀₂ as illustrated in Fig. 1.	
9.		Turn VR ₈₀₄ clockwise and adjust current to 15 to 10mA at 25°C or less or to 20 to 15mA at 25°C or more.	
10.		Attach F ₈₀₂ in place.	

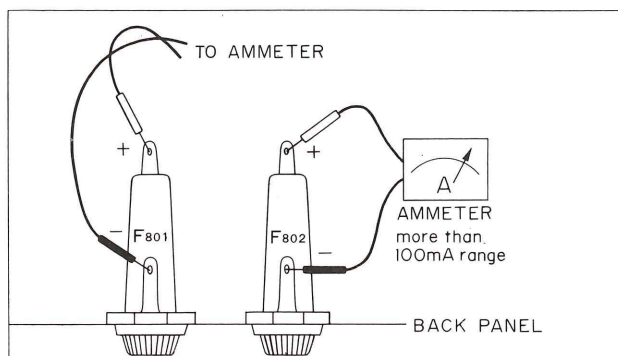

(Fig. 1) QUICK-ACTING FUSE HOLDER

2. OUTPUT ADJUSTMENT

STEP	WHAT TO DO	NOTE
1.	Adjust the volume control to minimum.	
2.	Set an oscillator to 1,000Hz and connect it to the LEFT AUX input.	The oscillator used should have the oscillation frequency of 20 to 20,000Hz and the output voltage of more than 200mV.
3.	Set the SELECTOR switch to AUX.	
4.	Connect a 8- or 16-ohm load resistor having capacitor of more than 50 watts to the LEFT SPEAKER output.	
5.	Connect an oscilloscope to the SPEAKER terminal.	
6.	Push the POWER switch on and advance the volume little by little. Check the output at the terminal by means of the oscilloscope.	
7.	Adjust VR ₈₀₁ so that the fronts of sine wave are clipped simultaneously	
8.	Adjust the right channel as above. In Step 7, adjust VR ₈₀₃ .	

PRINTED CIRCUIT SHEETS AND PARTS LIST

X: Parts No Y: Parts Name Z: Position of Parts

F-1222 <TONE CONTROL BLOCK>

X	Y	Z
R701	1kΩ ±10% ¼W Carbon Resistor	2C
R702	47kΩ ±10% ¼W Carbon Resistor	1D
R703	68kΩ ±10% ¼W Carbon Resistor	1C
R704	100kΩ ±10% ¼W Carbon Resistor	1D
R705	1kΩ ±10% ¼W Carbon Resistor	1D
R706	270kΩ ±10% ¼W Carbon Resistor	1C
R707	3.9kΩ ±10% ¼W Carbon Resistor	1C
R708	8.2kΩ ±10% ¼W Carbon Resistor	1C
R709	2.7kΩ ±10% ¼W Carbon Resistor	1C
R710	6.8kΩ ±10% ¼W Carbon Resistor	2B
R711	6.8kΩ ±10% ¼W Carbon Resistor	2B
R712	10kΩ ±10% ¼W Carbon Resistor	2B
R713	10kΩ ±10% ¼W Carbon Resistor	2A
R714	22kΩ ±10% ¼W Carbon Resistor	1A
R715	150kΩ ±10% ¼W Carbon Resistor	2A
R716	150kΩ ±10% ¼W Carbon Resistor	1B
R717	390kΩ ±10% ¼W Carbon Resistor	1B
R718	560Ω ±10% ¼W Carbon Resistor	1A
R719	5.6kΩ ±10% ¼W Carbon Resistor	1A
R720	100kΩ ±10% ¼W Carbon Resistor	1A
R721	1kΩ ±10% ¼W Carbon Resistor	2D
R722	47kΩ ±10% ¼W Carbon Resistor	2D
R723	68kΩ ±10% ¼W Carbon Resistor	2C
R724	100kΩ ±10% ¼W Carbon Resistor	1D
R725	1kΩ ±10% ¼W Carbon Resistor	2D
R726	270kΩ ±10% ¼W Carbon Resistor	2C
R727	3.9kΩ ±10% ¼W Carbon Resistor	1D
R728	8.2kΩ ±10% ¼W Carbon Resistor	1C
R729	2.7kΩ ±10% ¼W Carbon Resistor	2C
R730	6.8kΩ ±10% ¼W Carbon Resistor	2B
R731	6.8kΩ ±10% ¼W Carbon Resistor	2B
R732	10kΩ ±10% ¼W Carbon Resistor	2A
R733	10kΩ ±10% ¼W Carbon Resistor	2A
R734	22kΩ ±10% ¼W Carbon Resistor	1A
R735	150kΩ ±10% ¼W Carbon Resistor	2A
R736	150kΩ ±10% ¼W Carbon Resistor	2B
R737	390kΩ ±10% ¼W Carbon Resistor	1B
R738	560Ω ±10% ¼W Carbon Resistor	1B
R739	5.6kΩ ±10% ¼W Carbon Resistor	1B
R740	100kΩ ±10% ¼W Carbon Resistor	1A
C701	0.01μF ±10% 50 WV Mylar Capacitor	2C
C702	0.22μF ±10% 50 WV Mylar Capacitor	2D
C703	220μF 25 WV Electrolytic Capacitor	2D
C704	33μF 6.3 WV Electrolytic Capacitor	1C
C705	22pF ±10% 50 WV Ceramic Capacitor	1C
C706	33μF 15 WV Electrolytic Capacitor	2C
C707	1μF 50 WV Electrolytic Capacitor	1C
C708	0.015μF ±10% 50 WV Mylar Capacitor	1C
C709	0.0015μF ±10% 50 WV Mylar Capacitor	2B
C710	0.04μF ±10% 50 WV Mylar Capacitor	2A
C711	0.04μF ±10% 50 WV Mylar Capacitor	2A
C712	10μF 50 WV Electrolytic Capacitor	1B
C713	100μF ±10% 50 WV Ceramic Capacitor	1B
C714	47μF 6.3 WV Electrolytic Capacitor	1A
C715	1μF 50 WV Electrolytic Capacitor	1A
C716	0.01μF ±10% 50 WV Mylar Capacitor	2D

X	Y	Z
C717	0.22μF ±10% 50 WV Mylar Capacitor	2D
C718	33μF 6.3 WV Electrolytic Capacitor	2C
C719	22pF ±10% 50 WV Ceramic Capacitor	1C
C720	33μF 15 WV Electrolytic Capacitor	2C
C721	1μF 50 WV Electrolytic Capacitor	2C
C722	0.015μF ±10% 50 WV Mylar Capacitor	1C
C723	0.0015μF ±10% 50 WV Mylar Capacitor	2B
C724	0.04μF ±10% 50 WV Mylar Capacitor	2A
C725	0.04μF ±10% 50 WV Mylar Capacitor	2A
C726	10μF 50 WV Electrolytic Capacitor	2B
C727	100pF ±10% 50 WV Ceramic Capacitor	1B
C728	47μF 6.3 WV Electrolytic Capacitor	2B
C729	1μF 50 WV Electrolytic Capacitor	1A
VR701	250kΩ M, N Balance Control (101040)	2D
VR705		2D
VR702	250kΩ B Volume Control (101020)	2C
VR706		2C
VR703	100kΩ B Bass Control (102004)	2B
VR707		2B
VR704	100kΩ B Treble Control (102004)	2A
VR708		2A
TR701	2SC458 LG(C) (030531)	1D
TR702	2SC458 LG(B) (030531)	1C
TR703	2SC458 LG(C) (030531)	1A
TR704	2SC458 LG(C) (030531)	1D
TR705	2SC458 LG(B) (030531)	1C
TR706	2SC458 LG(C) (030531)	1B

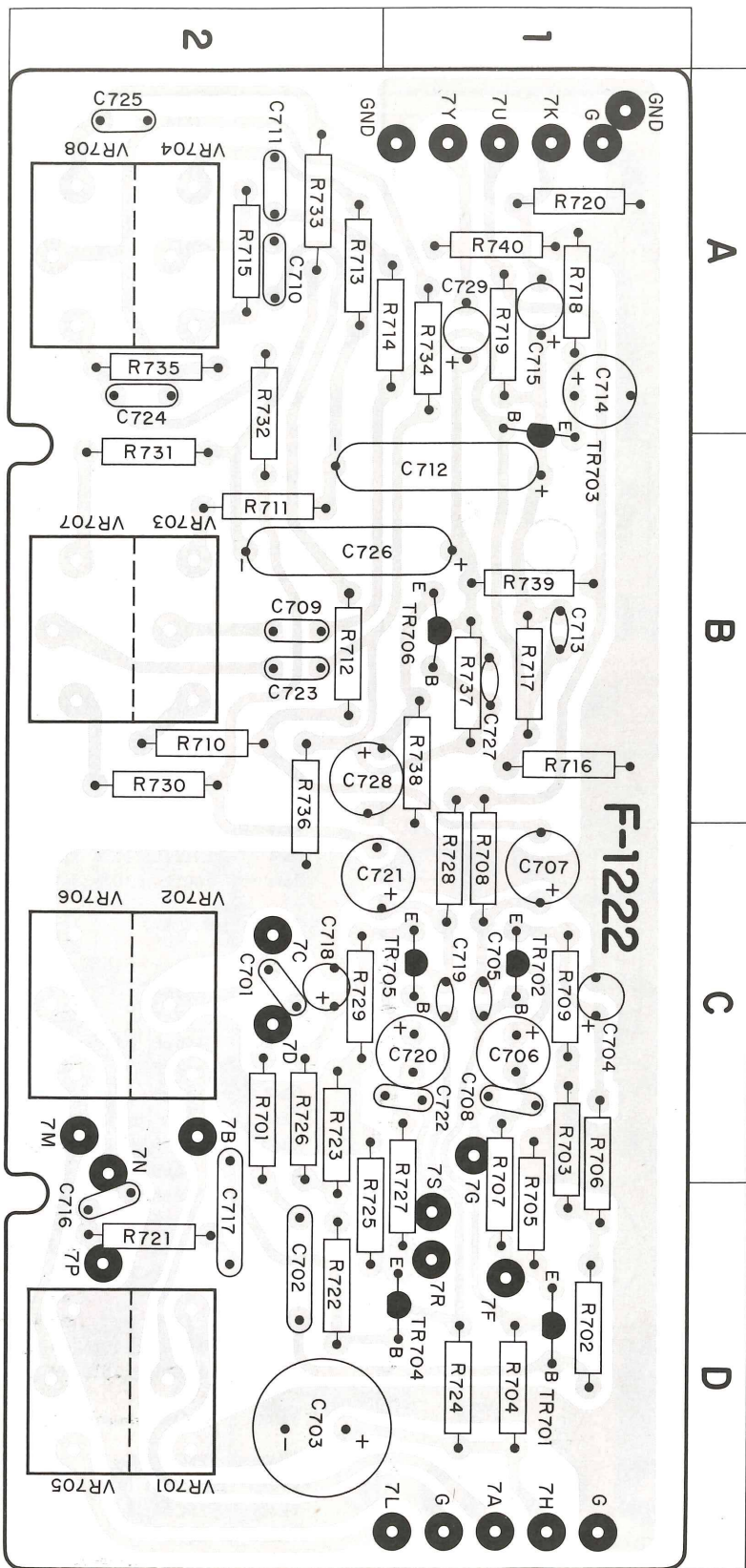

PRINTED CIRCUIT SHEETS AND PARTS LIST

X: Parts No Y: Parts Name Z: Position of Parts

F-1253 <EQUALIZER AMP. BLOCK>

X	Y	Z
R601	1k Ω \pm 10% $\frac{1}{4}$ W Carbon Resistor	1 B
R602	680k Ω \pm 10% $\frac{1}{4}$ W Carbon Resistor	1 B
R603	4.7k Ω \pm 10% $\frac{1}{4}$ W Carbon Resistor	1 A
R604	100k Ω \pm 10% $\frac{1}{4}$ W Carbon Resistor	1 B
R605	1.8k Ω \pm 10% $\frac{1}{4}$ W Carbon Resistor	1 B
R606	470 Ω \pm 10% $\frac{1}{4}$ W Carbon Resistor	1 B
R607	390k Ω \pm 10% $\frac{1}{4}$ W Carbon Resistor	1 B
R608	6.8k Ω \pm 10% $\frac{1}{4}$ W Carbon Resistor	1 A
R609	220 Ω \pm 10% $\frac{1}{4}$ W Carbon Resistor	1 A
R610	680 Ω \pm 10% $\frac{1}{4}$ W Carbon Resistor	1 A
R611	12k Ω \pm 10% $\frac{1}{4}$ W Carbon Resistor	1 A
R612	100 Ω \pm 10% $\frac{1}{4}$ W Carbon Resistor	1 A
R615	25k Ω \pm 10% $\frac{1}{4}$ W Carbon Resistor	1 A
R616	390k Ω \pm 10% $\frac{1}{4}$ W Carbon Resistor	1 A
R617	3.9k Ω \pm 10% $\frac{1}{4}$ W Carbon Resistor	1 A
R618	1k Ω \pm 10% $\frac{1}{4}$ W Carbon Resistor	2 B
R619	680k Ω \pm 10% $\frac{1}{4}$ W Carbon Resistor	2 B
R620	4.7k Ω \pm 10% $\frac{1}{4}$ W Carbon Resistor	2 A
R621	100k Ω \pm 10% $\frac{1}{4}$ W Carbon Resistor	2 B
R622	1.8k Ω \pm 10% $\frac{1}{4}$ W Carbon Resistor	2 B
R623	470 Ω \pm 10% $\frac{1}{4}$ W Carbon Resistor	2 B
R624	390k Ω \pm 10% $\frac{1}{4}$ W Carbon Resistor	2 B
R625	6.8k Ω \pm 10% $\frac{1}{4}$ W Carbon Resistor	2 A
R626	220 Ω \pm 10% $\frac{1}{4}$ W Carbon Resistor	2 A
R627	680 Ω \pm 10% $\frac{1}{4}$ W Carbon Resistor	2 A
R628	12k Ω \pm 10% $\frac{1}{4}$ W Carbon Resistor	2 A
R629	100 Ω \pm 10% $\frac{1}{4}$ W Carbon Resistor	2 A
R632	25k Ω \pm 10% $\frac{1}{4}$ W Carbon Resistor	2 A
R633	390k Ω \pm 10% $\frac{1}{4}$ W Carbon Resistor	2 A
R634	3.9k Ω \pm 10% $\frac{1}{4}$ W Carbon Resistor	2 A
R644	100 Ω \pm 10% $\frac{1}{4}$ W Carbon Resistor	2 B
C601	1.5 μ F 15 WV Tantalum Capacitor	1 B
C602	150 pF \pm 10% 25 WV Ceramic Capacitor	1 B
C603	33 μ F 6.3 WV Electrolytic Capacitor	1 B
C604	33 μ F 6.3 WV Electrolytic Capacitor	1 B
C605	150 pF \pm 10% 25 WV Ceramic Capacitor	1 B
C606	47 μ F 6.3 WV Electrolytic Capacitor	1 B
C607	10 μ F 25 WV Electrolytic Capacitor	1 A
C609	0.01 μ F \pm 10% 50 WV Mylar Capacitor	1 A
C610	0.03 μ F \pm 10% 50 WV Mylar Capacitor	1 A
C611	1.5 μ F 15 WV Tantalum Capacitor	2 B
C612	150 pF \pm 10% 25 WV Ceramic Capacitor	2 B
C613	33 μ F 6.3 WV Electrolytic Capacitor	2 B
C614	33 μ F 6.3 WV Electrolytic Capacitor	2 B
C615	150 pF \pm 10% 25 WV Ceramic Capacitor	2 B
C616	47 μ F 6.3 WV Electrolytic Capacitor	2 B
C617	10 μ F 25 WV Electrolytic Capacitor	2 B
C619	0.01 μ F \pm 10% 50 WV Mylar Capacitor	2 A
C620	0.03 μ F \pm 10% 50 WV Mylar Capacitor	2 A
VR601	3k Ω B Separation Adjustor (103066)	1 B, 2 B
TR601	2SC871 F (103054)	1 B
TR602	2SC871 F (030547-2)	1 B
TR603	2SC871 F (030547-2)	2 B
TR604	2SC871 F (030547-2)	2 B

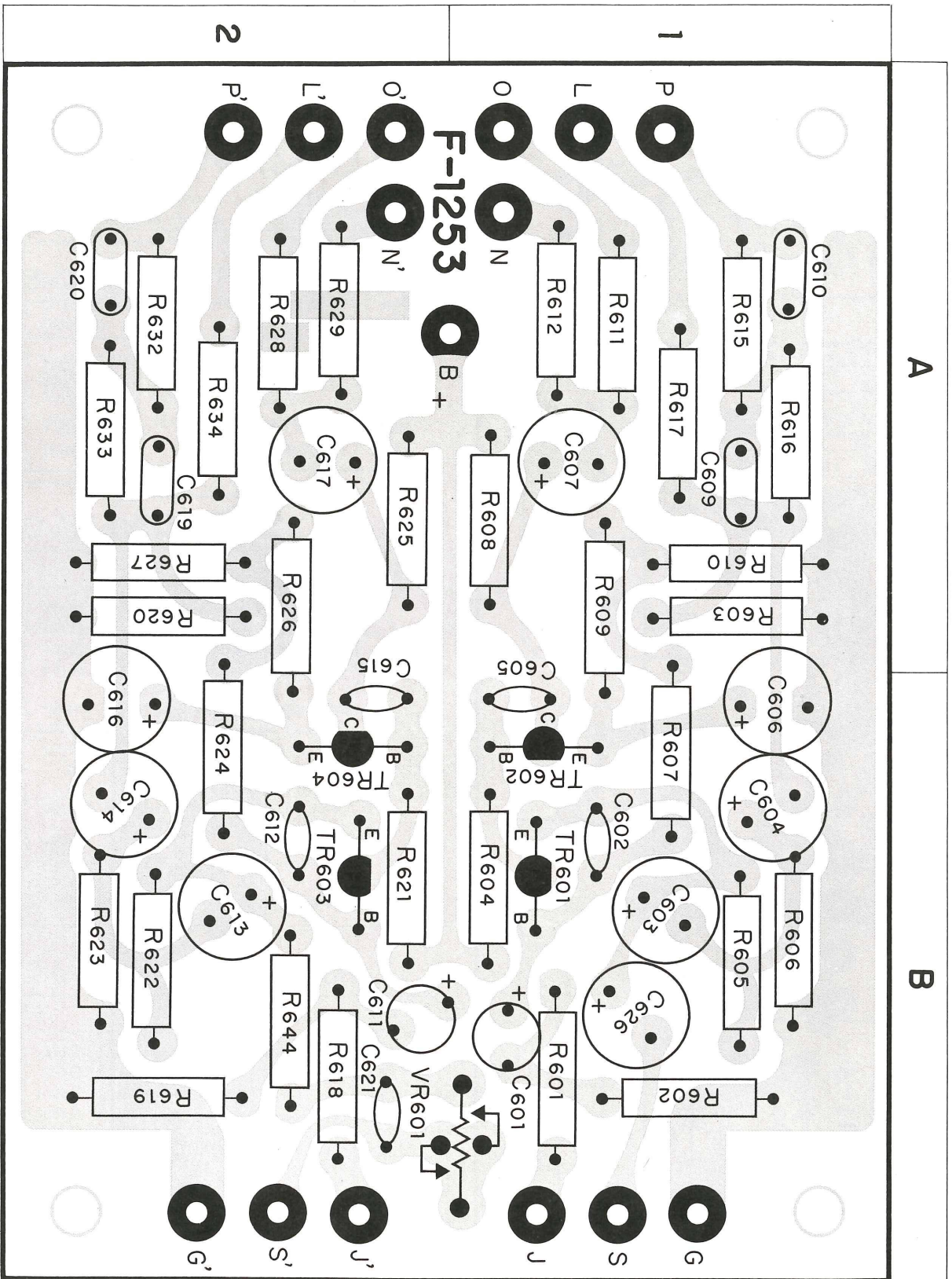

A

B

PRINTED CIRCUIT SHEETS AND PARTS LIST

X: Parts No Y: Parts Name Z: Position of Parts

F-1197 <RECTIFIER BLOCK>

X	Y	Z
R001	12k Ω \pm 10% $\frac{1}{2}$ W Solid Resistor	
R002	6.8 Ω \pm 10% $\frac{1}{2}$ W Solid Resistor	
R003	560 Ω \pm 10% 3 W Wire Wound Resistor	
C001	200 μ F 75 WV Electrolytic Capacitor	
C002	5 μ F 75 WV Electrolytic Capacitor	
D001	SA-3Z (031042)	
D002	SA-3Z (031042)	
D003	10D-1 (031035)	
D004	10D-1 (031035)	
TR001	2SC627 (0305581-3)	

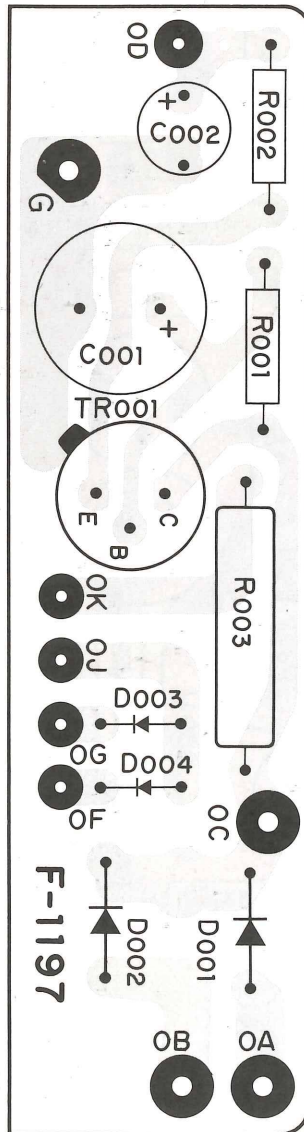

F-1195 <RIPPLE FILTER BLOCK>

X	Y	Z
R004	68 Ω \pm 10% 3 W Wire Wound Resistor	
R005	180 Ω \pm 10% 3 W Wire Wound Resistor	
R006	3.9k Ω \pm 10% $\frac{1}{4}$ W Carbon Resistor	
R007	1.5k Ω \pm 10% $\frac{1}{4}$ W Carbon Resistor	
C005	220 μ F 25 WV Electrolytic Capacitor	
C006	330 μ F 16 WV Electrolytic Capacitor	
C007	330 μ F 10 WV Electrolytic Capacitor	
D005	10D-2 (031034-1)	
D006	10D-2 (031034-1)	
D007	10D-1 (031034)	
ZD001	ZB-1-25 Zener Diode (031071)	
ZD002	ZB-1-14 Zener Diode (031069-1)	
TR002	2SC971 (030553-1)	
TR003	2SD205 (030813)	

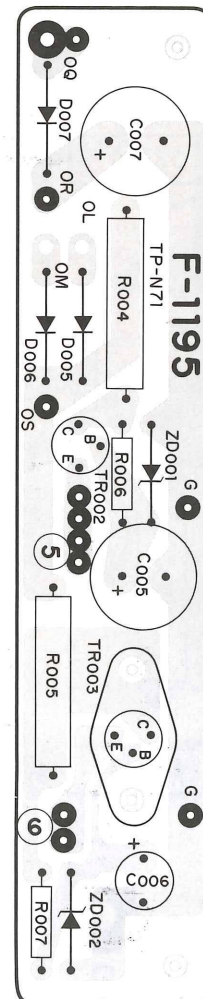

F-1224 <NOISE CANCELER AND MUTING BLOCK>

X	Y
R433	3.3MΩ ±10% ½W Solid Resistor
C430	330pF ±10% 50 WV Mica Capacitor
S6, S7	(113013-1)

F-1223 <HIGH-LOW FILTER BLOCK>

X	Y	Z
R741	1MΩ ±10% ¼W Carbon Resistor	
R742	1MΩ ±10% ¼W Carbon Resistor	
R743	1MΩ ±10% ¼W Carbon Resistor	
R744	1MΩ ±10% ¼W Carbon Resistor	
S8, S9	(113007)	

F-1220 AM METER BLOCK

X	Y	Z
R322	68kΩ ±10% ¼W Carbon Resistor	
R323	330kΩ ±10% ¼W Carbon Resistor	
R324	2.2kΩ ±10% ¼W Carbon Resistor	
R325	4.7kΩ ±10% ¼W Carbon Resistor	
C332	0.01μF 50 WV Ceramic Capacitor	
C333	0.001μF 50 WV Ceramic Capacitor	
C334	0.01μF 50 WV Ceramic Capacitor	
C335	1μF 50 WV Electrolytic Capacitor	
VR302	50kΩB AM Meter Adjustor	(103049)
D306	IN60	(031033)
D307	IN60	(031033)
TR305	25C460(B)	(030535~1)

F-1254 <ACCESSORIES BLOCK>

X	Y	Z
R747	27kΩ ±10% ¼W Carbon Resistor	1B
R748	27kΩ ±10% ¼W Carbon Resistor	1B
R749	100kΩ ±10% ¼W Carbon Resistor	1A
R750	100kΩ ±10% ¼W Carbon Resistor	1A
C735	0.02μF ±10% 50 WV Mylar Capacitor	1B
C736	150pF ±10% 50 WV Mica Capacitor	1B
C737	0.02μF ±10% 50 WV Mylar Capacitor	1B
C738	150pF ±10% 50 WV Mica Capacitor	1B
C739	0.47μF ±20% 25 WV Al. Solid Capacitor	1A
C740	0.47μF ±20% 25 WV Al. Solid Capacitor	1A
S2,3,4,5	(113014)	

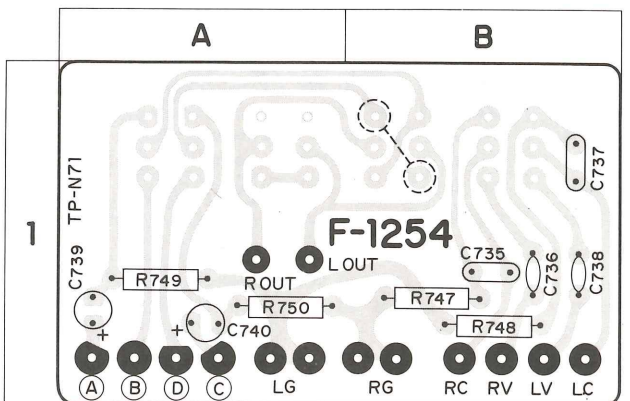
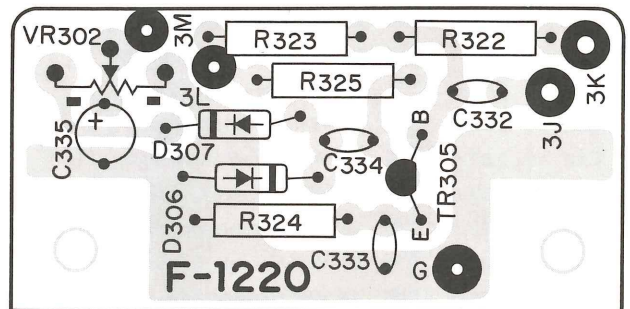
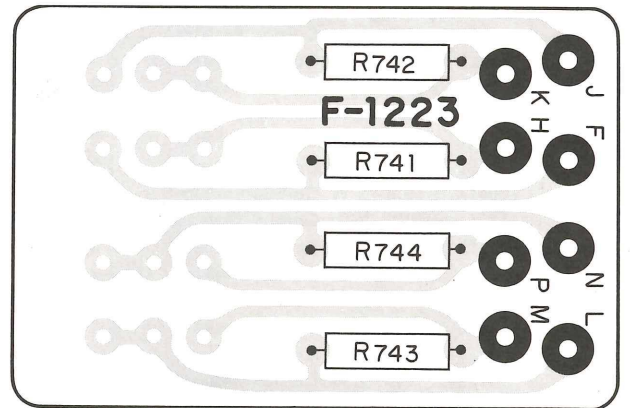
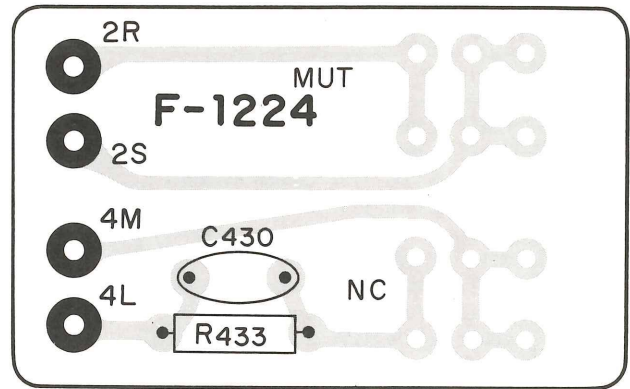

PRINTED CIRCUIT SHEETS AND PARTS LIST

X: Parts No Y: Parts Name Z: Position of Parts

F-1214 <FM IF BLOCK>

X	Y	Z
R201	1.5k Ω \pm 10% $\frac{1}{4}$ W Carbon Resistor	1 A
R202	68 Ω \pm 10% $\frac{1}{4}$ W Carbon Resistor	1 C
R203	1k Ω \pm 10% $\frac{1}{4}$ W Carbon Resistor	1 D
R204	1k Ω \pm 10% $\frac{1}{4}$ W Carbon Resistor	1 D
R205	56 Ω \pm 10% $\frac{1}{4}$ W Carbon Resistor	1 D
R206	22k Ω \pm 10% $\frac{1}{4}$ W Carbon Resistor	2 D
R207	100k Ω \pm 10% $\frac{1}{4}$ W Carbon Resistor	2 A
R208	220k Ω \pm 10% $\frac{1}{4}$ W Carbon Resistor	2 A
R209	680 Ω \pm 10% $\frac{1}{4}$ W Carbon Resistor	2 A
R210	68k Ω \pm 10% $\frac{1}{4}$ W Carbon Resistor	2 B
R211	22k Ω \pm 10% $\frac{1}{4}$ W Carbon Resistor	2 A
R212	10k Ω \pm 10% $\frac{1}{4}$ W Carbon Resistor	2 A
R213	1k Ω \pm 10% $\frac{1}{4}$ W Carbon Resistor	2 B
R214	2.2k Ω \pm 10% $\frac{1}{4}$ W Carbon Resistor	2 C
R215	22 Ω \pm 10% $\frac{1}{4}$ W Carbon Resistor	2 B
R216	22 Ω \pm 10% $\frac{1}{4}$ W Carbon Resistor	2 C
R217	10k Ω \pm 10% $\frac{1}{4}$ W Carbon Resistor	2 C
R218	1k Ω \pm 10% $\frac{1}{4}$ W Carbon Resistor	2 C
R219	68k Ω \pm 10% $\frac{1}{4}$ W Carbon Resistor	2 C
R220	100k Ω \pm 10% $\frac{1}{4}$ W Carbon Resistor	2 D
R222	18k Ω \pm 10% $\frac{1}{4}$ W Carbon Resistor	2 D
R223	2.7k Ω \pm 10% $\frac{1}{4}$ W Carbon Resistor	2 C
R224	56 Ω \pm 10% $\frac{1}{4}$ W Carbon Resistor	2 C
R225	820 Ω \pm 10% $\frac{1}{4}$ W Carbon Resistor	2 D
R226	10k Ω \pm 10% $\frac{1}{4}$ W Carbon Resistor	1 D
R227	10k Ω \pm 10% $\frac{1}{4}$ W Carbon Resistor	2 D
R228	15k Ω \pm 10% $\frac{1}{4}$ W Carbon Resistor	1 A
R229	15k Ω \pm 10% $\frac{1}{4}$ W Carbon Resistor	1 B
R230	15k Ω \pm 10% $\frac{1}{4}$ W Carbon Resistor	2 B
C201	0.01 μ F $\frac{+80}{-20}\%$ 25 WV Ceramic Capacitor	1 A
C202	0.02 μ F $\frac{+80}{-20}\%$ 25 WV Ceramic Capacitor	1 A
C203	0.02 μ F $\frac{+80}{-20}\%$ 25 WV Ceramic Capacitor	1 A
C204	0.02 μ F $\frac{+80}{-20}\%$ 25 WV Ceramic Capacitor	1 A
C205	0.02 μ F $\frac{+80}{-20}\%$ 25 WV Ceramic Capacitor	1 B
C206	0.02 μ F $\frac{+80}{-20}\%$ 25 WV Ceramic Capacitor	1 B
C207	0.02 μ F $\frac{+80}{-20}\%$ 25 WV Ceramic Capacitor	1 B
C208	0.02 μ F $\frac{+80}{-20}\%$ 25 WV Ceramic Capacitor	1 B
C209	0.02 μ F $\frac{+80}{-20}\%$ 25 WV Ceramic Capacitor	1 C
C210	0.02 μ F $\frac{+80}{-20}\%$ 25 WV Ceramic Capacitor	1 C
C211	0.02 μ F $\frac{+80}{-20}\%$ 25 WV Ceramic Capacitor	1 C
C212	0.02 μ F $\frac{+80}{-20}\%$ 25 WV Ceramic Capacitor	1 C
C213	220 pF \pm 10% 50 WV Ceramic Capacitor	1 D
C214	220 pF \pm 10% 50 WV Ceramic Capacitor	1 D
C215	47 pF \pm 10% 50 WV Ceramic Capacitor	1 D
C216	10 μ F 10 WV Electrolytic Capacitor	1 D
C217	0.05 μ F $\frac{+80}{-20}\%$ 25 WV Ceramic Capacitor	2 A
C218	0.02 μ F $\frac{+80}{-20}\%$ 25 WV Ceramic Capacitor	2 A
C219	0.02 μ F $\frac{+80}{-20}\%$ 25 WV Ceramic Capacitor	2 A
C220	3.3 pF \pm 10% 50 WV Ceramic Capacitor	2 A
C221	3.3 pF \pm 10% 50 WV Ceramic Capacitor	2 A
C222	6.8 pF \pm 10% 50 WV Ceramic Capacitor	2 B
C223	0.02 μ F $\frac{+80}{-20}\%$ 25 WV Ceramic Capacitor	2 B

X	Y	Z
C224	0.02 μ F $\frac{+80}{-20}\%$ 25 WV Ceramic Capacitor	2 B
C225	0.02 μ F $\frac{+80}{-20}\%$ 25 WV Ceramic Capacitor	2 B
C226	0.02 μ F $\frac{+80}{-20}\%$ 25 WV Ceramic Capacitor	2 C
C227	0.02 μ F $\frac{+80}{-20}\%$ 25 WV Ceramic Capacitor	2 C
C228	330 pF \pm 10% 25 WV Ceramic Capacitor	2 C
C229	330 pF \pm 10% 25 WV Ceramic Capacitor	2 C
C230	0.05 μ F $\frac{+80}{-20}\%$ 25 WV Ceramic Capacitor	2 C
C231	0.02 μ F $\frac{+80}{-20}\%$ 25 WV Ceramic Capacitor	2 D
C232	1 μ F 50 WV Electrolytic Capacitor	2 D
VR202	50k Ω B Tuning Meter Adjustor (103020)	2 C
VR203	100k Ω B Muting Adjustor (103034)	2 D
T201	FM IFT 10.7MHz (423537)	1 A
T202	FM IFT 10.7MHz (423548)	1 B
T203	FM IFT 10.7MHz (423549)	1 C
T204	FM Detector 10.7MHz (423518)	1 D
T205	FM Meter Transformer 10.7MHz (423529)	2 B
L201	3.3 μ H Choke Coil (429001-1)	1 A
L202	3.3 μ H Choke Coil (429001-1)	1 B
L203	3.3 μ H Choke Coil (429001-1)	1 C
IC201	PA-7703E (036001)	1 A
IC202	PA-7703E (036001)	1 B
IC203	PA-7703E (036001)	1 B
IC204	PA-7703E (036001)	1 C
TR201	2SC 380 (O) (030533)	2 B
TR202	2SC 828 (T) (030527-4)	2 C
TR203	2SA 564 (P) or (Q) (030008,-1)	2 D
D201	IN60 (031033)	2 A
D202	IN60 (031033)	2 A
D203	IN60 (031033)	2 B
D204	IN60 (031033)	2 B
D205	IN60 (031033)	2 B

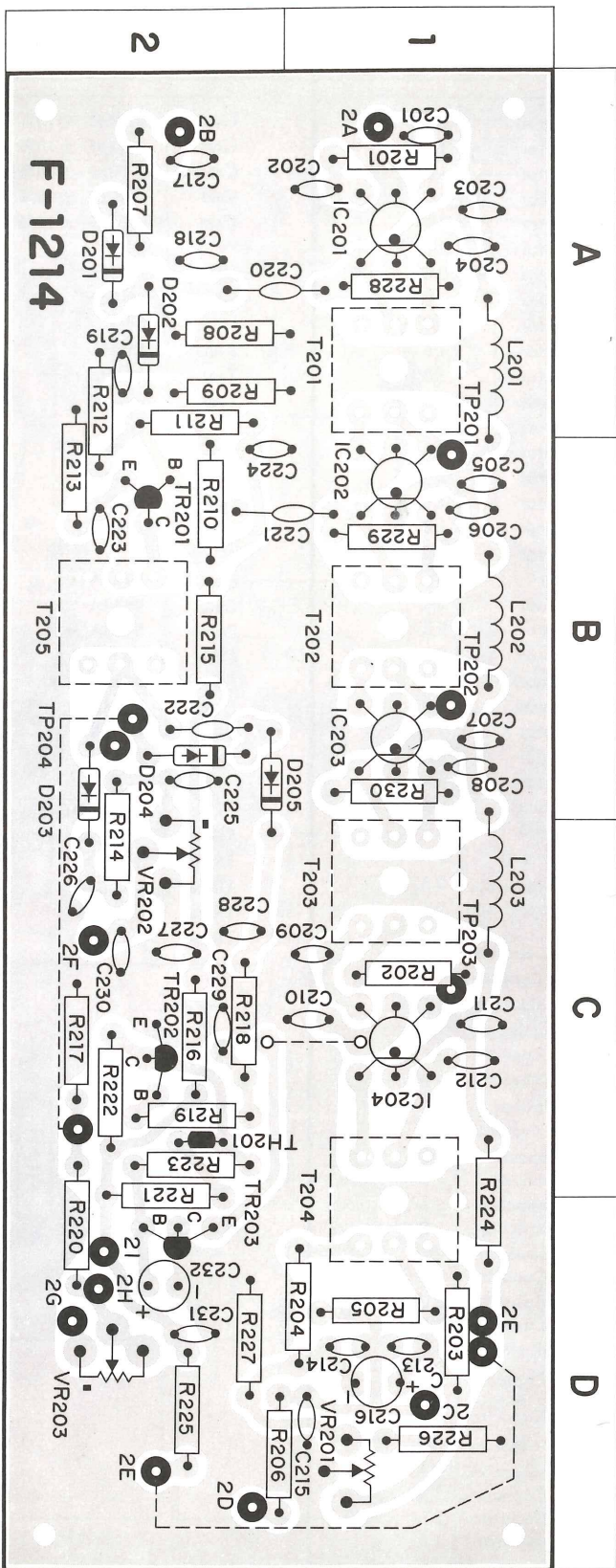

F-1214

PRINTED CIRCUIT SHEETS AND PARTS LIST

X: Parts No Y: Parts Name Z: Position of Parts

F-1190 <MULTIPLEX BLOCK>

X	Y	Z
R401	1kΩ ±10% ¼W Carbon Resistor	1C
R402	100kΩ ±10% ¼W Carbon Resistor	1C
R403	100kΩ ±10% ¼W Carbon Resistor	1C
R404	22kΩ ±10% ¼W Carbon Resistor	1C
R405	680Ω ±10% ¼W Carbon Resistor	1C
R406	100Ω ±10% ¼W Carbon Resistor	2C
R407	47kΩ ±10% ¼W Carbon Resistor	2C
R408	22kΩ ±10% ¼W Carbon Resistor	1C
R409	2.2kΩ ±10% ¼W Carbon Resistor	1C
R410	1kΩ ±10% ¼W Carbon Resistor	1B
R411	10kΩ ±10% ¼W Carbon Resistor	1B
R412	10kΩ ±10% ¼W Carbon Resistor	1B
R413	100kΩ ±10% ¼W Carbon Resistor	1B
R414	18kΩ ±10% ¼W Carbon Resistor	1B
R415	5.6kΩ ±10% ¼W Carbon Resistor	2A
R416	470Ω ±10% ¼W Carbon Resistor	1B
R417	2.2kΩ ±10% ¼W Carbon Resistor	1B
R418	10kΩ ±10% ¼W Carbon Resistor	2C
R419	1.2MΩ ±10% ¼W Solid Resistor	2C
R420	4.7kΩ ±10% ¼W Carbon Resistor	2C
R421	3.3kΩ ±10% ¼W Carbon Resistor	2B
R422	47Ω ±10% ¼W Carbon Resistor	2B
R423	1.8kΩ ±10% ¼W Carbon Resistor	2B
R424	6.8kΩ ±10% ¼W Carbon Resistor	2B
R425	22kΩ ±10% ¼W Carbon Resistor	1A
R426	22kΩ ±10% ¼W Carbon Resistor	1A
R427	22kΩ ±10% ¼W Carbon Resistor	2A
R428	22kΩ ±10% ¼W Carbon Resistor	2A
R429	100kΩ ±10% ¼W Carbon Resistor	1A
R430	220kΩ ±10% ¼W Carbon Resistor	1A
R431	100kΩ ±10% ¼W Carbon Resistor	2A
R432	220kΩ ±10% ¼W Carbon Resistor	2A
C401	100 pF ±10% 50 WV Ceramic Capacitor	1C
C402	1 μF 50 WV Electrolytic Capacitor	1C
C403	33 μF 6.3 WV Electrolytic Capacitor	1C
C404	5000 pF ±10% 50 WV Styrol Capacitor	1C
C405	10 μF 25 WV Electrolytic Capacitor	1C
C406	47 μF 25 WV Electrolytic Capacitor	2B
C407	0.02 μF ±10% 50 WV Mylar Capcitor	1B
C408	1 μF 50 WV Electrolytic Capacitor	1B
C409	6800 pF ±10% 50 WV Styrol Capacitor	1B
C410	0.02 μF ±10% 50 WV Mylar Capcitor	1B
C411	1700 pF ±10% 50 WV Styrol Capacitor	2A
C412	1500 pF ±10% 50 WV Styrol Capacitor	2D
C413	220 pF ±10% 50 WV Styrol Capacitor	2C
C414	330 pF ±10% 50 WV Ceramic Capacitor	2C
C415	330 pF ±10% 50 WV Ceramic Capacitor	2C
C416	50 pF ±10% 50 WV Ceramic Capacitor	2B
C417	10 μF 25 WV Electrolytic Capacitor	1B
C418	0.02 μF $\begin{matrix} +80\% \\ -20\% \end{matrix}$ 25 WV Ceramic Capacitor	2B
C419	0.02 μF $\begin{matrix} +80\% \\ -20\% \end{matrix}$ 25 WV Ceramic Capacitor	2B
C420	3.3 μF 25 WV Electrolytic Capacitor	2B
C421	10 μF 10 WV Electrolytic Capacitor	2A
C422	220 pF ±10% 50 WV Ceramic Capacitor	1A
C423	220 pF ±10% 50 WV Ceramic Capacitor	2A
C424	560 pF ±10% 50 WV Styrol Capacitor	1A

X	Y	Z
C425	1000 pF ±10% 50 WV Styrol Capacitor	1A
C426	0.03 μF ±10% 50 WV Mylar Capacitor	1A
C427	560 pF ±10% 50 WV Styrol Capacitor	2A
C428	1000 pF ±10% 50 WV Styrol Capacitor	2A
C429	0.03 μF ±10% 50 WV Mylar Capacitor	2A
CR401	FP-38A (080008)	1A
CR402	FP-38A (080008)	2A
T401	19kHz (424028)	1C
T402	19kHz (424029)	1B
T403	38kHz (424029)	1A
L401	4.7MH (490003)	1C
L402	4.7MH (490003)	2C
L403	68kHz (424026)	2C
L404	71kHz (424027)	2C
D401	IN34A (031040)	1B
D402	IN34A (031040)	1B
D403	IN34A Ⓢ (031040-1)	1A
D404	IN34A Ⓢ (031040-1)	1A
D405	IN34A Ⓢ (031040-1)	2A
D406	IN34A Ⓢ (031040-1)	2A
D407	IN34A (031040)	2B
D408	IN34A (031040)	2B
TR401	2SC458LG(B) (030531-1)	1C
TR402	2SC536V, E (0305244)	1B
TR403	2SC536V, E (0305244)	2B
TR404	2SC536V, E (0305244)	2C
TR405	2SA564 (030008-1)	2B
TR406	2SC536V, E (0305244)	2B

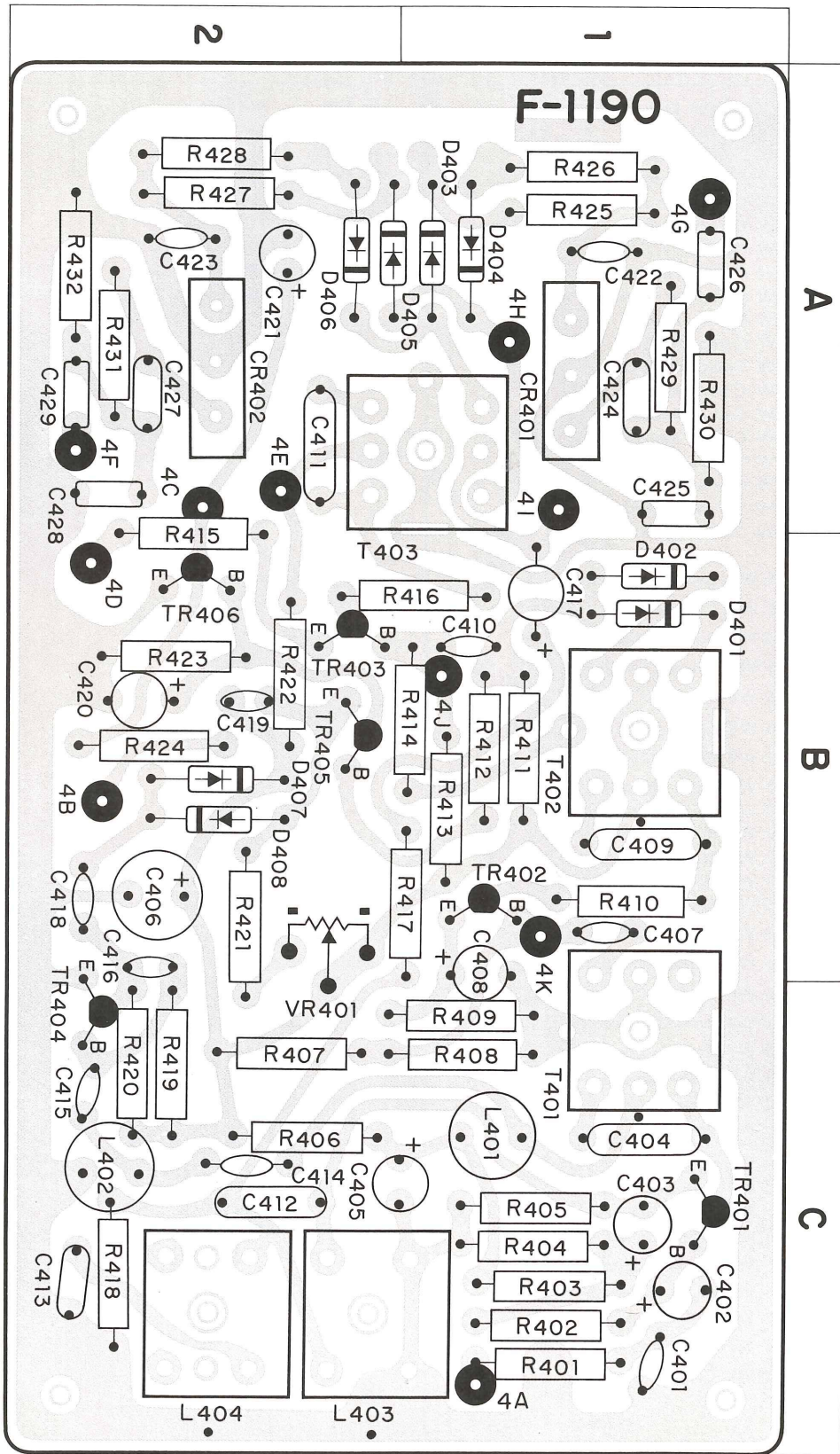

PRINTED CIRCUIT SHEETS AND PARTS LIST

X: Parts No Y: Parts Name Z: Position of Parts

F-10381 <AM IF BLOCK>

X	Y	Z
R301	1k Ω \pm 10% $\frac{1}{4}$ W Carbon Resistor	1 A
R302	100 Ω \pm 10% $\frac{1}{4}$ W Carbon Resistor	2 A
R303	3.9k Ω \pm 10% $\frac{1}{4}$ W Carbon Resistor	1 A
R304	33k Ω \pm 10% $\frac{1}{4}$ W Carbon Resistor	2 B
R305	100 Ω \pm 10% $\frac{1}{4}$ W Carbon Resistor	2 B
R306	56k Ω \pm 10% $\frac{1}{4}$ W Carbon Resistor	2 C
R307	22 Ω \pm 10% $\frac{1}{4}$ W Carbon Resistor	1 B
R308	22 Ω \pm 10% $\frac{1}{4}$ W Carbon Resistor	2 C
R309	1k Ω \pm 10% $\frac{1}{4}$ W Carbon Resistor	1 C
R311	10k Ω \pm 10% $\frac{1}{4}$ W Carbon Resistor	2 C
R312	22 Ω \pm 10% $\frac{1}{4}$ W Carbon Resistor	2 D
R313	100 Ω \pm 10% $\frac{1}{4}$ W Carbon Resistor	1 C
R314	6.8k Ω \pm 10% $\frac{1}{4}$ W Carbon Resistor	1 C
R315	470 Ω \pm 10% $\frac{1}{4}$ W Carbon Resistor	1 C
R316	8.2k Ω \pm 10% $\frac{1}{4}$ W Carbon Resistor	1 D
R318	1k Ω \pm 10% $\frac{1}{4}$ W Carbon Resistor	1 D
R319	120k Ω \pm 10% $\frac{1}{4}$ W Carbon Resistor	1 D
R320	1k Ω \pm 10% $\frac{1}{4}$ W Carbon Resistor	1 B
R321	4.7k Ω \pm 10% $\frac{1}{4}$ W Carbon Resistor	1 D
C301	0.04 μ F $\frac{+80}{-20}$ % 25 WV Ceramic Capacitor	1 A
C302	0.04 μ F $\frac{+80}{-20}$ % 25 WV Ceramic Capacitor	2 A
C303	100 μ F 6.3 WV Electrolytic Capacitor	1 A
C304	0.02 μ F $\frac{+80}{-20}$ % 25 WV Ceramic Capacitor	1 A
C305	0.04 μ F $\frac{+80}{-20}$ % 25 WV Ceramic Capacitor	2 A
C306	0.04 μ F $\frac{+80}{-20}$ % 25 WV Ceramic Capacitor	1 A
C307	0.02 μ F $\frac{+80}{-20}$ % 25 WV Ceramic Capacitor	2 B
C308	0.01 μ F \pm 10% 50 WV Mylar Capacitor	1 B
C309	430 pF \pm 5 % 50 WV Mica Capacitor	1 B
C310	100 μ F 16 WV Electrolytic Capacitor	2 B
C311	500 pF \pm 5 % 50 WV Mica Capacitor	2 B
C312	500 pF \pm 5 % 50 WV Mica Capacitor	2 A
C313	4.7 μ F 16 WV Electrolytic Capacitor	2 C
C314	0.02 μ F $\frac{+80}{-20}$ % 25 WV Ceramic Capacitor	2 B
C315	0.02 μ F $\frac{+80}{-20}$ % 25 WV Ceramic Capacitor	2 C
C316	0.04 μ F $\frac{+80}{-20}$ % 25 WV Ceramic Capacitor	1 B
C317	47 μ F 6.3 WV Electrolytic Capacitor	1 C
C318	0.02 μ F $\frac{+80}{-20}$ % 25 WV Ceramic Capacitor	2 C
C319	500 pF \pm 5 % 50 WV Mica Capacitor	2 C
C320	500 pF \pm 5 % 50 WV Mica Capacitor	1 C
C322	0.04 μ F $\frac{+80}{-20}$ % 25 WV Ceramic Capacitor	1 C
C323	0.02 μ F $\frac{+80}{-20}$ % 25 WV Ceramic Capacitor	2 C
C324	220 μ F 16 WV Electrolytic Capacitor	2 D
C325	500 pF \pm 5 % 50 WV Mica Capacitor	2 D
C326	500 pF \pm 5 % 50 WV Mica Capacitor	1 D
C327	0.02 μ F $\frac{+80}{-20}$ % 25 WV Ceramic Capacitor	1 C
C328	0.02 μ F \pm 10% 50 WV Mylar Capacitor	1 D
C329	0.1 μ F \pm 10% 50 WV Mylar Capacitor	1 D
C330	0.04 μ F $\frac{+80}{-20}$ % 25 WV Ceramic Capacitor	1 D
C332	0.005 μ F $\frac{+80}{-20}$ % 25 WV Ceramic Capacitor	
T301	AM RF (421005)	1 A, 2 A

X	Y	Z
T302	AM OSC (422007)	1 B, 2 B
T303	AM IFT 455kHz (423019)	1 B, 2 B
T304	AM IFT 455kHz (423019)	1 C, 2 C
T305	AM IFT 455kHz (423018)	1 D, 2 D
TR301	2SC460 $\text{\textcircled{C}}$ (030535-1)	2 A
TR302	2SC460 $\text{\textcircled{B}}$ (030535)	2 B
TR303	2SC460 $\text{\textcircled{B}}$ (030535)	1 C
TR304	2SC460 $\text{\textcircled{C}}$ (030535-1)	1 C
D301	IN60 (031033)	2 A
D302	IN60 (031033)	2 A
D303	IN60 (031033)	2 B
D304	IN60 (031033)	1 D

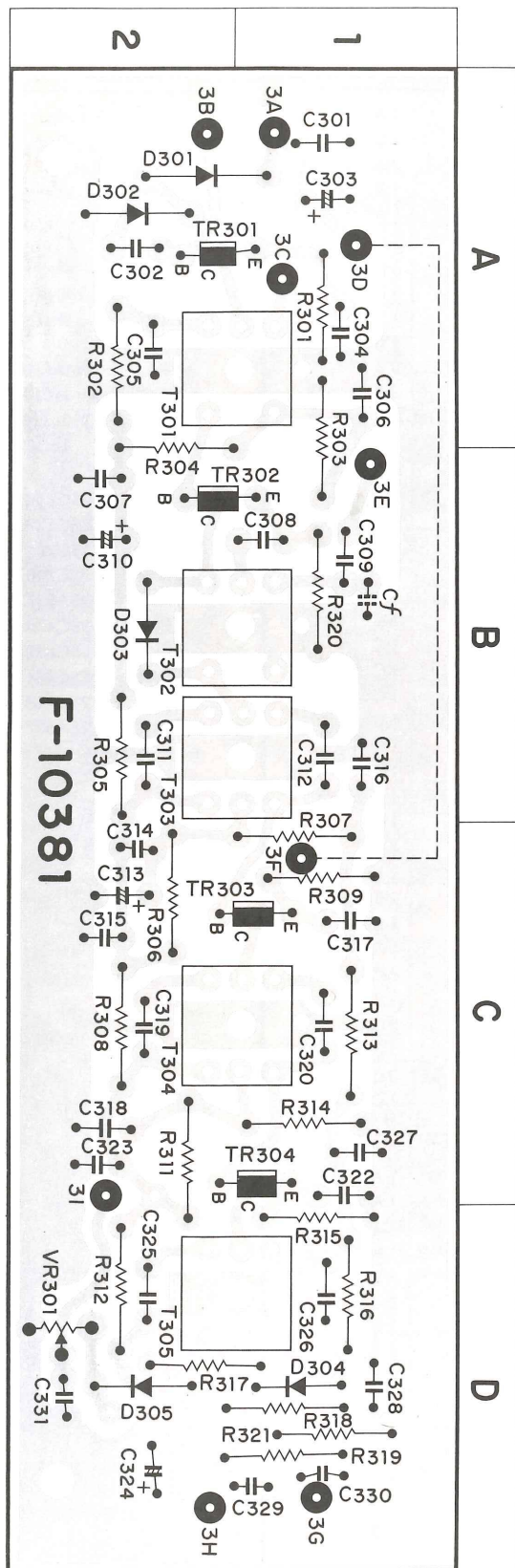

PRINTED CIRCUIT SHEETS AND PARTS LIST

X: Parts No Y: Parts Name Z: Position of Parts

F-1180 <DRIVER AMP. BROCK>

X	Y	Z
R801	2.2k Ω \pm 10% $\frac{1}{4}$ W Carbon Resistor	1 A
R802	150k Ω \pm 10% $\frac{1}{4}$ W Carbon Resistor	1 A
R803	560k Ω \pm 10% $\frac{1}{4}$ W Carbon Resistor	1 A
R804	220 Ω \pm 10% $\frac{1}{4}$ W Carbon Resistor	1 A
R805	3.3k Ω \pm 10% $\frac{1}{4}$ W Carbon Resistor	1 A
R806	3.3k Ω \pm 10% $\frac{1}{4}$ W Carbon Resistor	1 A
R807	10k Ω \pm 10% $\frac{1}{4}$ W Carbon Resistor	1 A
R808	47k Ω \pm 10% $\frac{1}{4}$ W Carbon Resistor	1 A
R809	56k Ω \pm 10% $\frac{1}{4}$ W Carbon Resistor	1 A
R810	1.8k Ω \pm 10% $\frac{1}{4}$ W Carbon Resistor	1 B
R811	3.9k Ω \pm 10% $\frac{1}{4}$ W Carbon Resistor	2 B
R812	39 Ω \pm 10% $\frac{1}{4}$ W Carbon Resistor	2 B
R813	3.3k Ω \pm 10% $\frac{1}{4}$ W Carbon Resistor	1 B
R814	1.5k Ω \pm 10% $\frac{1}{4}$ W Carbon Resistor	2 A
R815	220 Ω \pm 10% $\frac{1}{4}$ W Carbon Resistor	2 A
R816	100 Ω \pm 10% $\frac{1}{4}$ W Carbon Resistor	2 B
R817	4.7 Ω \pm 10% $\frac{1}{4}$ W Carbon Resistor	2 A
R818	100 Ω \pm 10% $\frac{1}{4}$ W Carbon Resistor	2 A
R819	22 Ω \pm 10% $\frac{1}{2}$ W Solid Resistor	2 A
R820	8.2k Ω \pm 10% $\frac{1}{4}$ W Carbon Resistor	1 A
R821	2.2k Ω \pm 10% $\frac{1}{4}$ W Carbon Resistor	1 C
R822	150k Ω \pm 10% $\frac{1}{4}$ W Carbon Resistor	1 C
R823	560k Ω \pm 10% $\frac{1}{4}$ W Carbon Resistor	1 C
R824	220 Ω \pm 10% $\frac{1}{4}$ W Carbon Resistor	1 C
R825	3.3k Ω \pm 10% $\frac{1}{4}$ W Carbon Resistor	1 C
R826	3.3k Ω \pm 10% $\frac{1}{4}$ W Carbon Resistor	1 C
R827	10k Ω \pm 10% $\frac{1}{4}$ W Carbon Resistor	1 C
R828	47k Ω \pm 10% $\frac{1}{4}$ W Carbon Resistor	1 C
R829	56k Ω \pm 10% $\frac{1}{4}$ W Carbon Resistor	1 C
R830	1.8k Ω \pm 10% $\frac{1}{4}$ W Carbon Resistor	1 B
R831	3.9k Ω \pm 10% $\frac{1}{4}$ W Carbon Resistor	2 B
R832	39 Ω \pm 10% $\frac{1}{4}$ W Carbon Resistor	2 B
R833	3.3k Ω \pm 10% $\frac{1}{4}$ W Carbon Resistor	1 B
R834	1.5k Ω \pm 10% $\frac{1}{4}$ W Carbon Resistor	2 C
R835	220 Ω \pm 10% $\frac{1}{4}$ W Carbon Resistor	2 C
R836	100 Ω \pm 10% $\frac{1}{4}$ W Carbon Resistor	2 B
R837	4.7 Ω \pm 10% $\frac{1}{4}$ W Carbon Resistor	2 C
R838	100 Ω \pm 10% $\frac{1}{4}$ W Carbon Resistor	2 C
R839	22 Ω \pm 10% $\frac{1}{2}$ W Solid Resistor	2 C
R840	8.2k Ω \pm 10% $\frac{1}{4}$ W Carbon Resistor	1 C
C801	0.02 μ F \pm 10% 50 WV Mylar Capacitor	1 A
C802	100 μ F 25 WV Electrolytic Capacitor	1 A
C803	220 μ F 10 WV Electrolytic Capacitor	1 A
C804	1 μ F 50 WV Electrolytic Capacitor	1 A
C805	33 μ F 50 WV Electrolytic Capacitor	1 B
C806	100 μ F 10 WV Electrolytic Capacitor	2 A
C807	10 μ F 50 WV Electrolytic Capacitor	1 B
C808	0.047 μ F \pm 10% 50 WV Mylar Capacitor	2 A
C809	15 pF \pm 10% 50 WV Ceramic Capacitor	1 A
C810	68 pF \pm 10% 50 WV Ceramic Capacitor	1 A
C811	0.22 μ F \pm 10% 50 WV Mylar Capacitor	1 C
C812	100 μ F 25 WV Electrolytic Capacitor	1 C
C813	220 μ F 10 WV Electrolytic Capacitor	1 C
C814	1 μ F 50 WV Electrolytic Capacitor	1 C
C815	33 μ F 50 WV Electrolytic Capacitor	1 B

X	Y	Z
C816	100 μ F 10 WV Electrolytic Capacitor	2 C
C817	10 μ F 50 WV Electrolytic Capacitor	1 B
C818	0.047 μ F \pm 10% 50 WV Mylar Capacitor	2 C
C819	15 pF \pm 10% 50 WV Ceramic Capacitor	1 C
C820	68 pF \pm 10% 50 WV Ceramic Capacitor	1 C
C823	47 pF \pm 10% 50 WV Ceramic Capacitor	2 A
C824	47 pF \pm 10% 50 WV Ceramic Capacitor	2 C
C825	220 pF \pm 10% 50 WV Ceramic Capacitor	2 B
C826	220 pF \pm 10% 50 WV Ceramic Capacitor	2 B
VR801	200k Ω B AC Balance Adjustor (103015)	1 A, 1 B
VR802	1k Ω B DC Bias Adjustor (103051)	2 A, 2 B
VR803	200k Ω B AC Balance Adjustor (103015)	1 B, 1 C
VR804	1k Ω B DC Bias Adjustor (103051)	2 B, 2 C
TR801	2SC458LG (C) (030531-1)	1 A
TR802	2SC627 (1), (2) (030558-1-2)	2 A
TR803	2SC281 (B) (0305121-2)	2 A, 2 B
TR804	2SC708A (0305480-2)	2 B
TR805	2SA537A (0300120-2)	2 A
TR806	2SC458LG (C) (030531-1)	1 C
TR807	2SC627 (1), (2) (030558-1-2)	2 C
TR808	2SC281 (B) (0305121-2)	2 B, 2 C
TR809	2SC708 A (0305480-2)	2 B
TR810	2SA537 A (0300120-2)	2 C

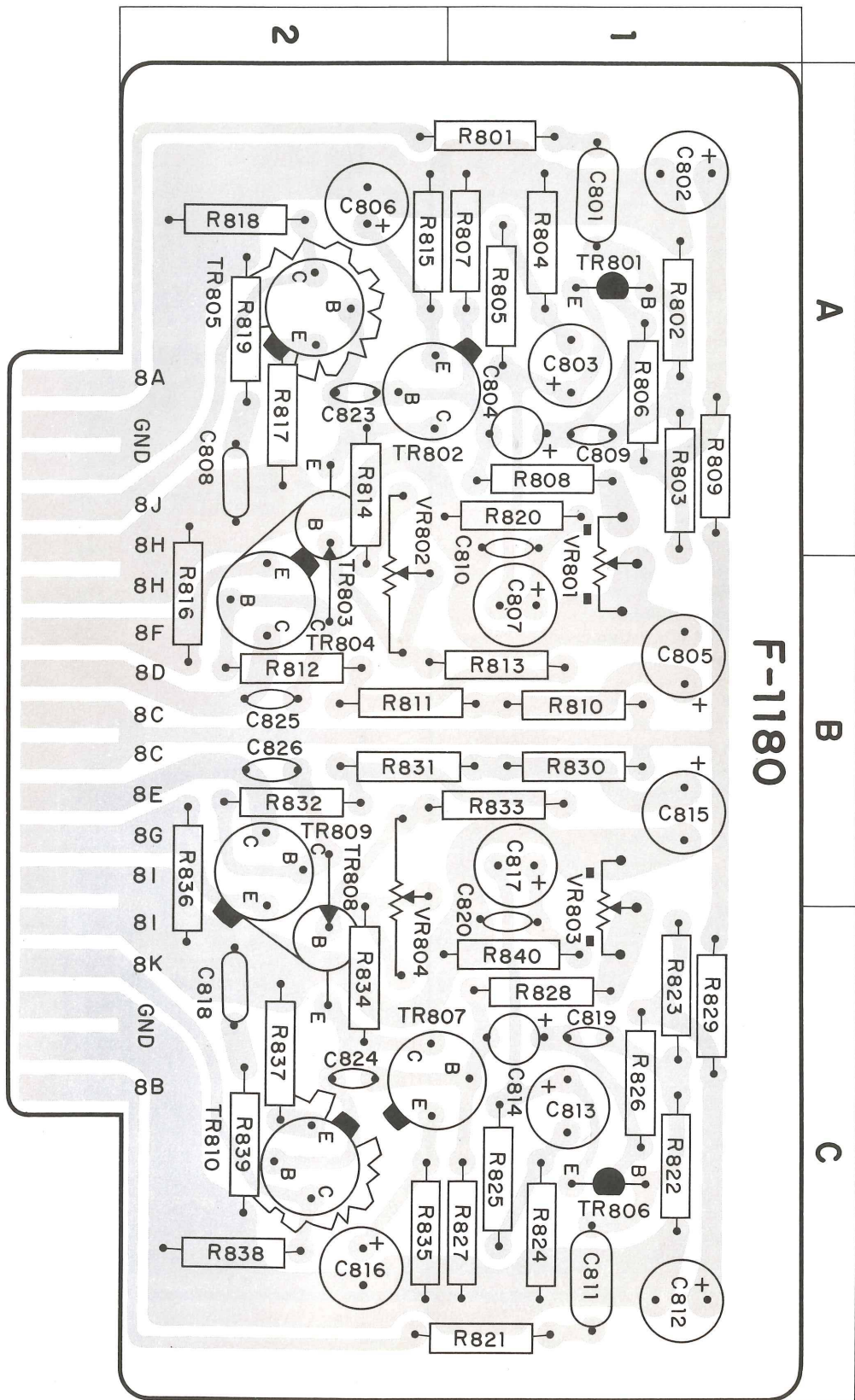

F-1180

A

B

C

2

1

OTHER PARTS AND THEIR POSITION ON CHASSIS

X: Parts No Y: Parts Name

X	Y
R008	1.2kΩ ±10% 1/2W Solid Resistor
R009	150Ω ±10% 1/4W Carbon Resistor
R010	10Ω ±10% 1/4W Carbon Resistor
R011	18Ω ±10% 1/4W Carbon Resistor
R120	56Ω ±10% 1/4W Carbon Resistor
R121	680Ω ±10% 1/4W Carbon Resistor
R635	68kΩ ±10% 1/4W Carbon Resistor
R636	180kΩ ±10% 1/4W Carbon Resistor
R637	100kΩ ±10% 1/4W Carbon Resistor
R638	22kΩ ±10% 1/4W Carbon Resistor
R639	15kΩ ±10% 1/4W Carbon Resistor
R640	100kΩ ±10% 1/4W Carbon Resistor
R641	220kΩ ±10% 1/4W Carbon Resistor
R642	100kΩ ±10% 1/4W Carbon Resistor
R643	220kΩ ±10% 1/4W Carbon Resistor
R645	68kΩ ±10% 1/4W Carbon Resistor
R646	180kΩ ±10% 1/4W Carbon Resistor
R647	100kΩ ±10% 1/4W Carbon Resistor
R648	15kΩ ±10% 1/4W Carbon Resistor
R841	0.5Ω ±10% 2 W Wire Wound Resistor
R842	0.5Ω ±10% 2 W Wire Wound Resistor
R843	330Ω ±10% 1/2W Solid Resistor
R844	0.5Ω ±10% 2 W Wire Wound Resistor
R845	0.5Ω ±10% 2 W Wire Wound Resistor
R846	330Ω ±10% 1/2W Solid Resistor
R847	560Ω ±10% 1 W Metal Film Resistor
R848	560Ω ±10% 1 W Metal Film Resistor
C003	2200μF 80 WV Electrolytic Capacitor
C004	1000μF 50 WV Electrolytic Capacitor
C008	0.033μF 600 WV Oil Capacitor
C009	0.0047μF 600 WV Oil Capacitor
C011	0.04μF 50 WV Ceramic Capacitor
C012	0.04μF 50 WV Ceramic Capacitor
C013	0.01μF 400 WV Oil Capacitor
C014	0.01μF 400 WV Oil Capacitor
C622	100pF ±10% 50 WV Ceramic Capacitor
C623	100pF ±10% 50 WV Ceramic Capacitor
C624	100pF ±10% 50 WV Ceramic Capacitor
C625	100pF ±10% 50 WV Ceramic Capacitor
C821	2200μF 75 WV Electrolytic Capacitor
C822	2200μF 75 WV Electrolytic Capacitor
VR204	1MΩB Muting Adjustor (100508)
S001	UEH 12CD00 (113016)
S1(a~i)	Y-4-9-6 (110412)
S10	Y-1-4-4 ()
S11	SL-13-8-10H6-2-2 (111004)
J001	Headphones Jack (243007)
J002	DIN Connector (243004)
TR407	2SB324 (030311)
TR811~814	2SD202 (030820-1)
CO001,2	AC Outlet (245001)
PU001	Multi Connector (242002)
PU002	Voltage Selector (241017)

X	Y
M001	Tuning Meter (090020)
T001	400-5338 Power Trans. 200μA (400051)
PL001	7V 0.2A PHONO 1, 2 AUX Indicator (040015)
PL002	
PL008	
PL003	
PL004	6.3V 0.25A Dial Scale Lamp (040008)
PL005	
PL006	
PL007	
PL011	25V 0.09A Protector Indicator (040007)
PL009	
PL010	
PL012	5V 0.06A Dial Pointer (040010-1)
VC301~303	AM 3-Gang Variable Capacitor (120002)
T306	9G-013 (420027)
T102	300Ω-75Ω Balance (429002-1)
F001	Power Fuse (3A) (043004)
F801	Quick Acting Fuse (2.5A) (043011-1)
F802	Quick Acting Fuse (2.5A) (043011-1)

* All rights reserve specifications subject to change without notice.

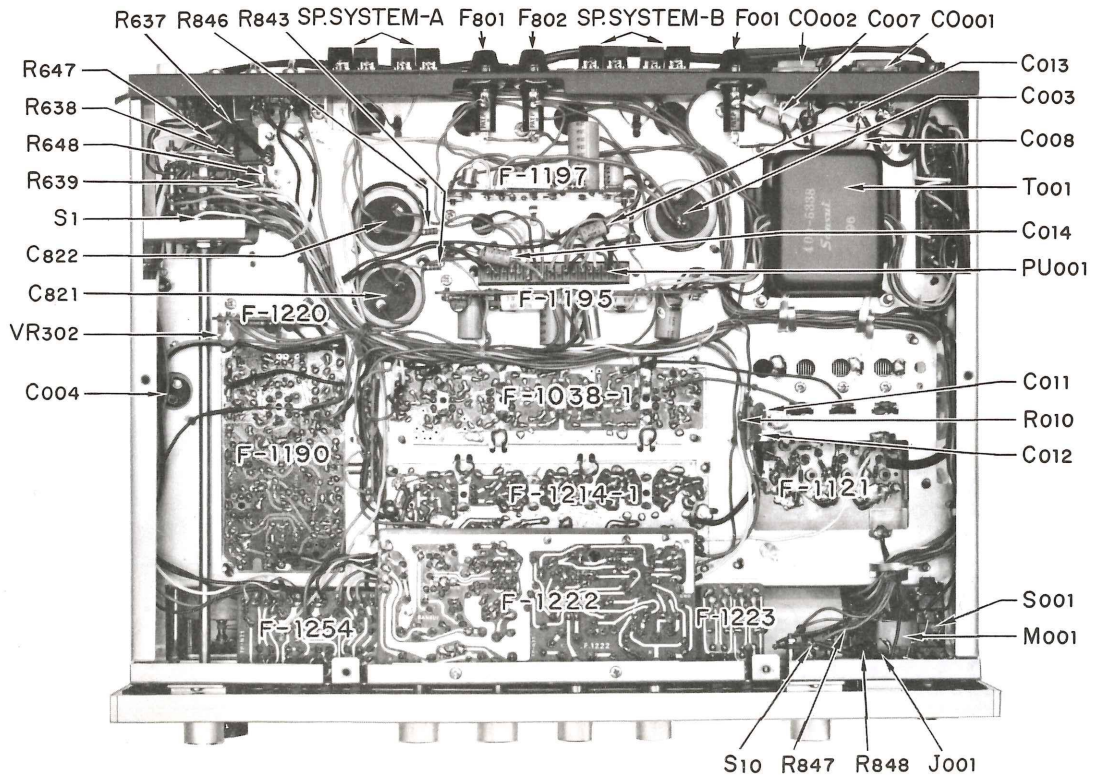
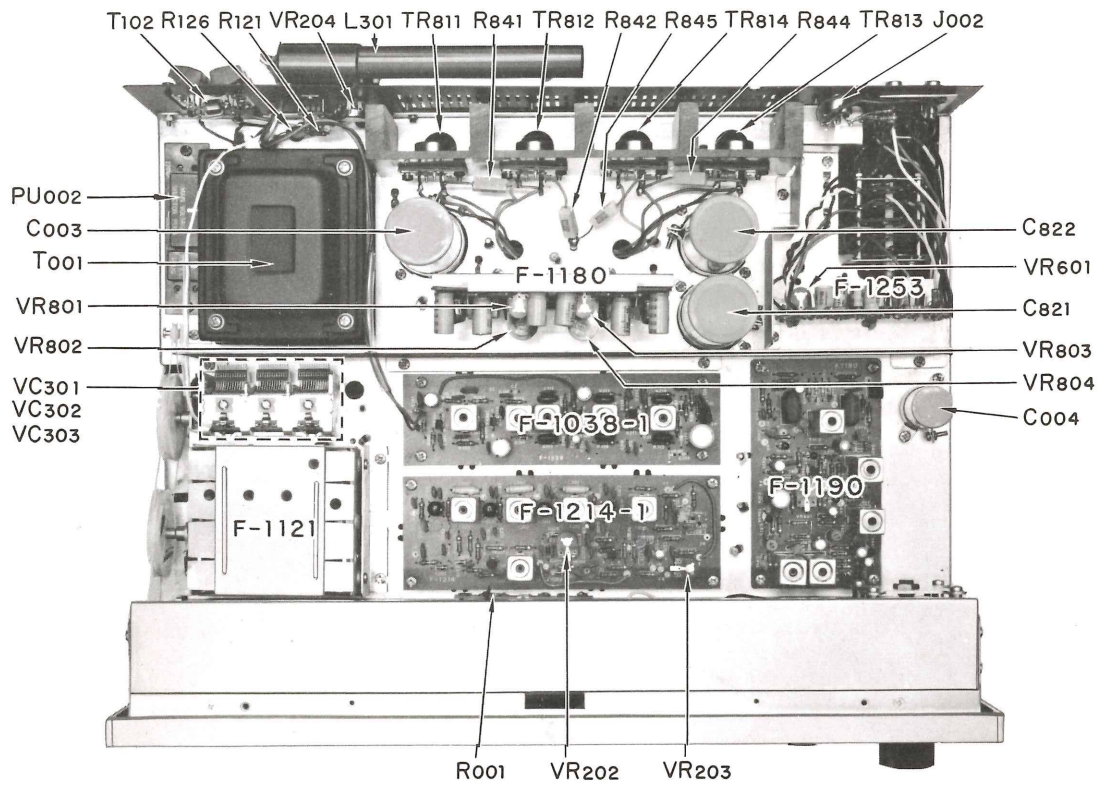



SANSUI ELECTRIC COMPANY LIMITED

Head Office; 14-1, 2-chome, Izumi, Suginami-ku, Tokyo, Japan. TEL. 323-1111

Printed in Japan (O9001M)