

# SERVICE MANUAL

TWO-SPEED DIRECT-DRIVE TURNTABLE

**SANSUI SR-717**



SANSUI ELECTRIC CO., LTD.

**HILBERINK**  
Electronics-Acoustics  
P.O. Box 4217  
6202 WB MAASTRICHT  
The Netherlands

This service manual is designed for service engineers to repair, adjust, maintain and order the replacement parts of the SR-717 correctly. When ordering the parts, use the stock number and parts name specifically referring to the parts list.

For general usage and maintenance of the unit, please refer to the operating instructions attached with the unit.

## 1. SPECIFICATIONS

TYPE .....	Two-Speed Direct Drive
SPEEDS .....	33 $\frac{1}{3}$ and 45r.p.m.
FINE SPEED ADJUSTMENT RANGE .....	$\pm 4\%$
PLATTER .....	Aluminum alloy die cast 30cm (12") diameter, 1.4kg (3.1 lbs)
MOTOR .....	20-pole brushless DC serbo-type
WOW & FLUTTER.....	0.035% (W.R.M.S.)
S/N .....	Better than 60dB
TONARM .....	Statically-balanced S-shaped tubular
TONARM LENGTH ....	235mm (9 $\frac{1}{4}$ ")
OVERHANG .....	16.5mm ( $\frac{5}{8}$ ")
SUITABLE CARTRIDGE WEIGHT .....	4 to 11g (11 to 18g using sub-weight)
FEATURES .....	Direct-readout stylus pressure dial, 4-contact plug-in head shell, oil-damped tonearm lifter, inside-force canceller, lateral balancer, sub-weight etc.
POWER REQUIREMENTS ..	100, 117, 220, 240V 50/60Hz
POWER CONSUMPTION ..	5W (Rated)
DIMENSIONS .....	508mm (20") W, 182mm (7 $\frac{3}{16}$ ") H, 394mm (15 $\frac{1}{2}$ ") D
WEIGHT .....	13.1kg (28.9 lbs) net, 15.1kg (33.3 lbs) packed

## TABLE OF CONTENTS

1. SPECIFICATIONS .....	1
2. PARTS LOCATIONS AND PARTS LIST .....	2, 3, 4
3. DISASSEMBLY WITH EXPLODED VIEWS, PARTS LOCATIONS AND PARTS LIST .....	5, 6
4. SCHEMATIC DIAGRAM .....	6
5. WIRING .....	6
6. ADJUSTMENT .....	7
7. PACKING LIST .....	7
8. ACCESSORY PARTS LIST .....	7

\* Design and specifications subject to change without notice for improvement.

## 2. PARTS LOCATIONS AND PARTS LIST

2-1. S-0003-1 Power Supply Circuit Board (Stock No. 7500950 Complete Circuit Board S-0003-1)

Conductor Side

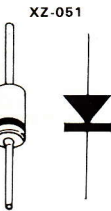
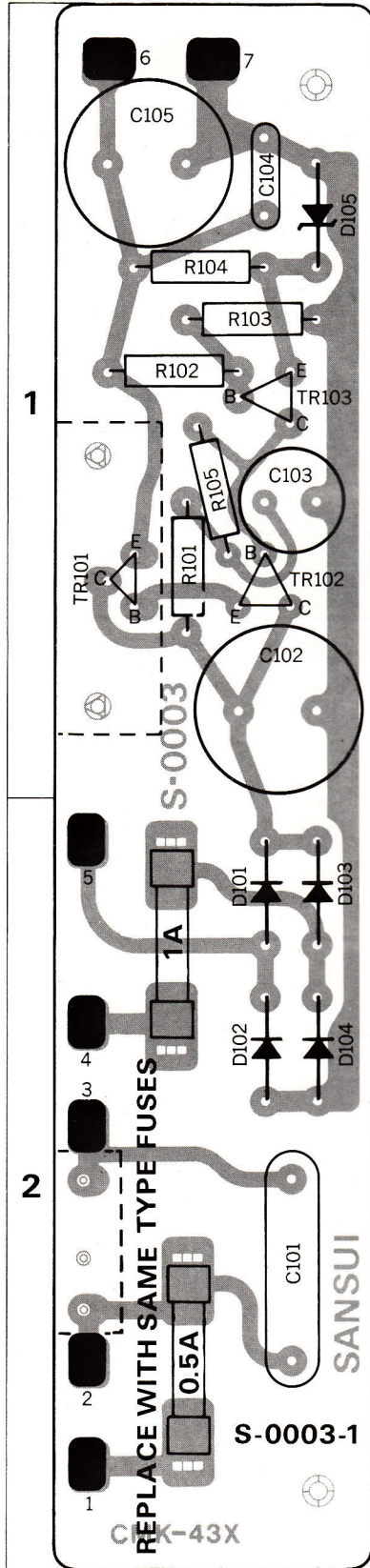

### Parts List

Parts No.	Stock No.	Description	Position	
TR102	0306141, 2	2SC1362 ⑤ (7, 8)	Transistor	
		or		
	0306144, 5	2SC1362 ⑥ (7, 8)		
		or		
TR103	0306141, 2	2SC1362 ⑤ (7, 8)	1	
		or		
	0306144, 5	2SC1362 ⑥ (7, 8)		
		or		
D101	0310340	10D-1	Diode	2
D102	0310340	10D-1		2
D103	0310340	10D-1		2
D104	0310340	10D-1		2
D105	0316380	XZ-051	Zener Diode	1
C101	0605476	0.0047 μF 250V	M.C.	2
C102	0515471	470 μF 50V	E.C.	1
C103	0513470	47 μF 25V	E.C.	1
C104	0657473	47000 pF 50V	C.C.	1
C105	0513471	470 μF 25V	E.C.	1
R101	0107561	560 Ω	± 5 % 1/4 W C.R.	1
R102	0107222	2.2K Ω		1
R103	0107821	820 Ω		1
R104	0107152	1.5K Ω		1
R105	0107332	3.3K Ω		1
	0432640	0.5A	Power Fuse	2
	0432660	1A		2

### Abbreviations

C.R.	: Carbon Resistor	BP.E.C.:	Bi-Polar Electrolytic Capacitor
S.R.	: Solid Resistor	C.C.	: Ceramic Capacitor
Ce.R.	: Cement Resistor	Mi.C.	: Mica Capacitor
M.R.	: Metallized Film Resistor	O.C.	: Oil Capacitor
M.C.	: Mylar Capacitor	P.C.	: Polystyrene Capacitor
E.C.	: Electrolytic Capacitor	T.C.	: Tantalum Capacitor

**2-2. S-0004-2 Control Circuit Board** (Stock No. 7630090 Complete Circuit Board S-0004-2)

**Conductor Side**

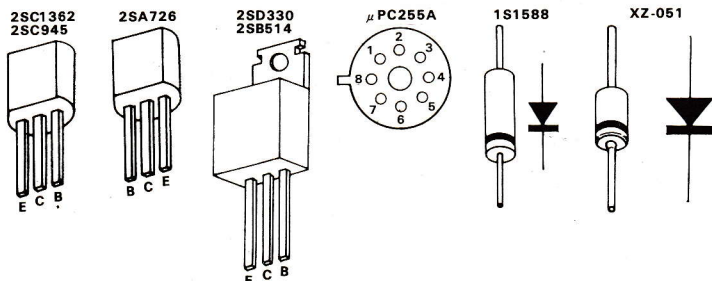
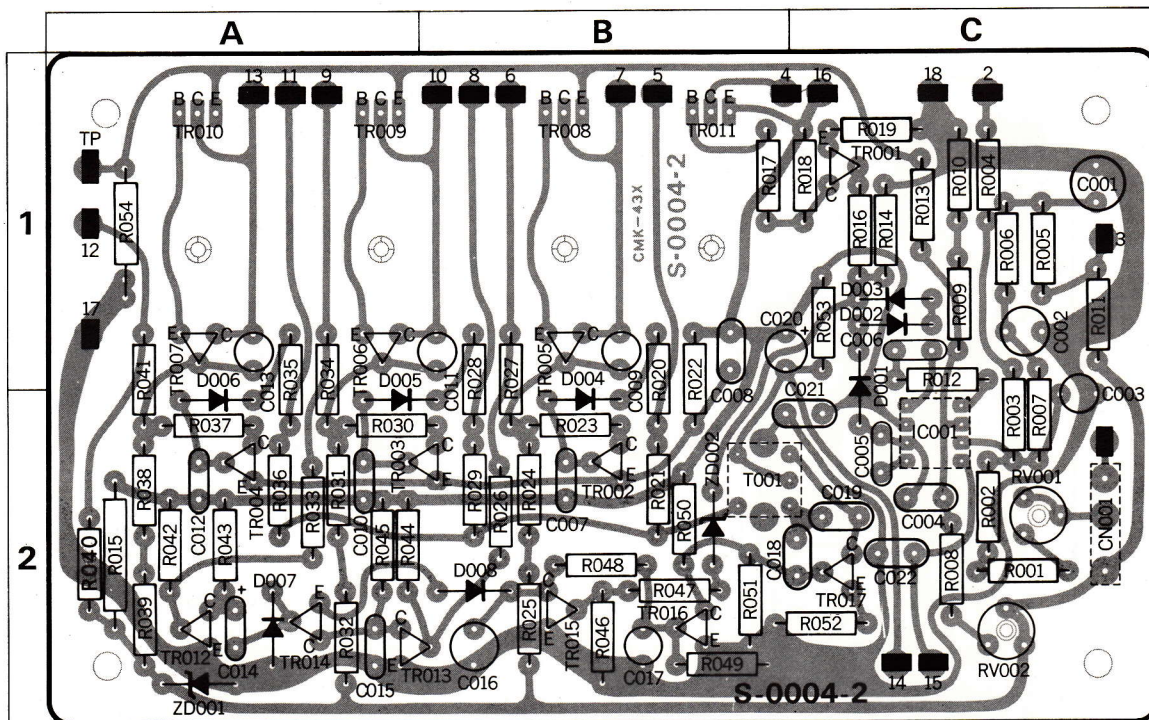

**Parts List**

Parts No.	Stock No.	Description	Position
TR001	0305951-3	2SC945 (Q, P, K)	1 C
TR002	0300410, 1	2SA726 <sup>®</sup> (F, G)	2 B
	or	or	
TR003	0300470, 1	2SA726 <sup>®</sup> (F, G)	2 A, B
	or	or	
	0300410, 1	2SA726 <sup>®</sup> (F, G)	
TR004	0300470, 1	2SA726 <sup>®</sup> (F, G)	2 A
	or	or	
	0300410, 1	2SA726 <sup>®</sup> (F, G)	
TR005	0306141	2SC1362 <sup>®</sup> (7)	Transistor 1 B
	or	or	
	0306144	2SC1362 <sup>®</sup> (7)	
	0306141	2SC1362 <sup>®</sup> (7)	
TR006	or	or	1 A
	0306144	2SC1362 <sup>®</sup> (7)	
	0306141	2SC1362 <sup>®</sup> (7)	
TR007	or	or	1 A
	0306144	2SC1362 <sup>®</sup> (7)	
TR008	0308362	2SD330 (E)	1 B
TR009	0308362	2SD330 (E)	1 A
TR010	0308362	2SD330 (E)	1 A

Parts No.	Stock No.	Description	Position
TR011	0303252, 3	2SB514 (E, F)	1 B
TR012	0305951-3	2SC945 (Q, P, K)	2 A
TR013	0305951-3	2SC945 (Q, P, K)	Transistor 2 A, B
TR014	0305951-3	2SC945 (Q, P, K)	
TR015	0505951-3	2SC945 (Q, P, K)	2 B
TR016	0305951-3	2SC945 (Q, P, K)	2 B
TR017	0305951-3	2SC945 (Q, P, K)	2 C
IC001	0360160	µpc255A IC	2 C
D001	0311180	1S1588	Diode 1, 2 C
D002	0311180	1S1588	
D003	0311180	1S1588	
D004	0311180	1S1588	
D005	0311180	1S1588	
D006	0311180	1S1588	
D007	0311180	1S1588	
D008	0311180	1S1588	
ZD001	0316380	XZ-051	Zener Diode 2 A
ZD002	0316380	XZ-051	
T001	4220560	CAN-30444R OSC Coil	2 B, C

Parts No.	Stock No.	Description	Position
C001	0532470	47 $\mu$ F 16V	1 C
C002	0533220	22 $\mu$ F 25V	1 C
C003	0533479	4.7 $\mu$ F 25V	1, 2 C
C004	0660220	220 pF 50V	2 C
C005	0660101	100 pF 50V	2 C
C006	0600226	0.0022 $\mu$ F 50V	1 C
C007	0600477	0.047 $\mu$ F 50V	2 B
C008	0600108	0.1 $\mu$ F 50V	1 B
C009	0535478	0.47 $\mu$ F 50V	1 B
C010	0600477	0.047 $\mu$ F 50V	2 A
C011	0535478	0.47 $\mu$ F 50V	1 B
C012	0600477	0.047 $\mu$ F 50V	2 A
C013	0535478	0.47 $\mu$ F 50V	1 A
C014	0519104	1.5 $\mu$ F 50V	2 A
C015	0657473	0.0047 $\mu$ F 50V	2 A
C016	0533220	22 $\mu$ F 25V	2 B
C017	0533229	2.2 $\mu$ F 25V	2 B
C018	0600226	0.0022 $\mu$ F 50V	2 C
C019	0600227	0.022 $\mu$ F 50V	2 C
C020	0519104	1.5 $\mu$ F 50V	1 B, C
C021	0657473	0.0047 $\mu$ F 50V	2 B, C
C022	0657473	0.0047 $\mu$ F 50V	2 C
R001	0107823	82k $\Omega$	2 C
R002	0107682	6.8k $\Omega$	2 C
R003	0107103	10k $\Omega$	1, 2 C
R004	0107124	120k $\Omega$	1 C
R005	0107102	1k $\Omega$	1 C
R006	0107123	1.2k $\Omega$	1 C
R007	0107103	10k $\Omega$	1, 2 C
R008	0107183	18k $\Omega$	2 C
R009	0107152	1.5k $\Omega$	1 C
R010	0107102	1k $\Omega$	1 C
R011	0107562	5.6k $\Omega$	1 C
R012	0107152	1.5k $\Omega$	1 C
R013	0107563	56k $\Omega$	1 C
R014	0107562	5.6k $\Omega$	1 C
R015	0104122	1.2k $\Omega$	2 A
R016	0107182	1.8k $\Omega$	1 C
R017	0107821	820 $\Omega$	1 B
R018	0107222	2.2k $\Omega$	1 C
R019	0107821	820 $\Omega$	1 C
R020	0107471	470 $\Omega$	1, 2 B
R021	0107561	560 $\Omega$	2 B
R022	0107392	3.9k $\Omega$	1, 2 B
R023	0107682	6.8k $\Omega$	2 B
R024	0107123	12k $\Omega$	2 B
R025	0107182	1.8k $\Omega$	2 B
R026	0107332	3.3k $\Omega$	2 B
R027	0107332	3.3k $\Omega$	1, 2 B
R028	0107471	470 $\Omega$	1, 2 B
R029	0107561	560 $\Omega$	2 B
R030	0107682	6.8k $\Omega$	2 A, B
R031	0107123	12k $\Omega$	2 A
R032	0107182	1.8k $\Omega$	2 A
R033	0107332	3.3k $\Omega$	2 A
R034	0107332	3.3k $\Omega$	1, 2 A
R035	0107471	470 $\Omega$	1, 2 A
R036	0107561	560 $\Omega$	2 A
R037	0107682	6.8k $\Omega$	2 A
R038	0107123	12k $\Omega$	2 A
R039	0107182	1.8k $\Omega$	2 A
R040	0107473	47k $\Omega$	2 A
R041	0107332	3.3k $\Omega$	1, 2 A
R042	0107154	150k $\Omega$	2 A

Parts No.	Stock No.	Description	Position
R043	0107222	2.2k $\Omega$	2 A
R044	0107154	150k $\Omega$	2 A
R045	0107222	2.2k $\Omega$	2 A
R046	0107222	2.2k $\Omega$	2 B
R047	0107682	6.8k $\Omega$	2 B
R048	0107562	5.6k $\Omega$	2 B
R049	0107332	3.3k $\Omega$	2 B
R050	0107823	82k $\Omega$	2 B
R051	0107104	100k $\Omega$	2 B
R052	0107121	120 $\Omega$	2 B, C
R053	0107181	180 $\Omega$	1 C
R054	0201229	2.2 $\Omega$ 1W C.R.	1 A
RV001	1035150	22k $\Omega$ (B)	2 C
RV002	1035130	10k $\Omega$ (B)	2 C

### 2-3. S-0005 Bias Circuit Board

(Stock No. 7500960 Complete Circuit Board S-0005)

#### Conductor Side

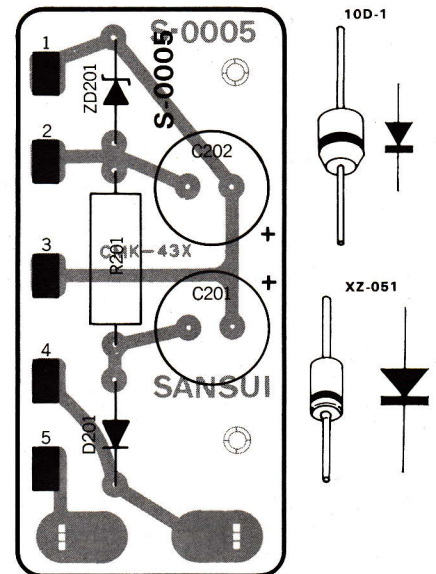

#### Parts List

Parts No.	Stock No.	Description
D201	0310340	10D-1 Diode
ZD201	0316380	XZ-051 Zener Diode
C201	0513221	220 $\mu$ F 25V E.C.
C202	0511471	470 $\mu$ F 10V E.C.
R201	0104561	560 $\Omega$ 1W C.R.

#### Abbreviations

<b>C.R.</b> : Carbon Resistor	<b>BP.E.C.:</b> Bi-Polar Electrolytic Capacitor
<b>S.R.</b> : Solid Resistor	<b>C.C.</b> : Ceramic Capacitor
<b>Ce.R.</b> : Cement Resistor	<b>Mi.C.</b> : Mica Capacitor
<b>M.R.</b> : Metallized Film Resistor	<b>O.C.</b> : Oil Capacitor
<b>M.C.</b> : Mylar Capacitor	<b>P.C.</b> : Polystyrene Capacitor
<b>E.C.</b> : Electrolytic Capacitor	<b>T.C.</b> : Tantalum Capacitor

### 3. DISASSEMBLY WITH EXPLODED VIEWS, PARTS LOCATIONS AND PARTS LIST

**Parts List** (※Differences between SR-717 and SR-717E)

Parts No.	Stock No.	Description	
1	7012050	Dust Cover Ass'y	
	5062220	Dust Cover	
	5362013	Name Plate, dust cover	
	6922210	Lock Plate	
	5502021	Rubber Cushion	
	5109563	B Type Screw, M4×10	
	2	5392111	Turntable Ring
		5502441	Rubber Mat, turntable
	3	6112110	Turntable (Platter)
	4	5108464	PT Type Screw, M3×12
5	5052030	Transformer Cover	
6	5107869	PSA Type Screw, M4×25	
7	4320300	Motor Ass'y	
8	7012040	Stroboscope Lamp Cover	
9	0410080	Stroboscope Lamp	
10	5107743	PSB Type Screw, M3×6	
11	5222210	Lock Plate, voltage selector	
12	5107768	PSB Type Screw, M4×20	
13	5107762	PSB Type Screw, M4×8	
14	5107744	PSB Type Screw, M3×8	
15	2090050	Voltage Selector (Socket)	
16		2410820	Voltage Selector (Plug)
17	5107743	PSB Type Screw, M3×6	
18	5107743	PSB Type Screw, M3×6	
19	5226012	Holder, bias circuit board ass'y	
20	7500960	Bias Circuit Board Ass'y (S-0005)	
21	7630090	Control Circuit Board Ass'y (S-0004-2)	
22	5107743	PSB Type Screw, M3×6	
23	5052050	Cover, lug terminal	
24	0104392	3.9kΩ 1W Carbon Resistor	
25	2110150	2L2 Lug Terminal	
26	5107743	PSB Type Screw, M3×6	
27	5107743	PSB Type Screw, M3×6	
28	2120010	M3 Lug Terminal	
29	5226012	Holder, power supply circuit board ass'y	
30	7500950	Power Supply Circuit Board Ass'y (S-0003-1)	
31	3910490	Cord Stopper	
32	3800020	Power Cord (KP-200)	
33	5106533	P Type Screw, M3×6	
34	0308392	Transistor 2SD313 (E)	
35	5107762	PSB Type Screw, M4×8	
36	4002060	Power Transformer	
37	5242422	Bottom Plate	
38	5103072	P Type Screw, M4×40	
39	5120161	P Type Washer, 4φ	
40	5108465	PT Type Screw, M3×12	
41	5512100	Insulator	
42		Bottom Plate (A)	
43	5103040	P Type Screw, M3×3	
44		Nut, tonearm	
45		Washer, tonearm	
46	5182431	Blind Washer	
47		Tonearm Base	
48	5162470	Hexagon Socket Head Capscrew, M3×20	
49		Control Base Ass'y	
50		Head Shell Ass'y (SR-717)	
		Not Included in SR-717E	
51	6642110	Head Shell Sub Ass'y	

Parts No.	Stock No.	Description
※52	4310190	Cartridge Ass'y (SC-38)
		Not Included in SR-717E
53	7092300	Tonearm Ass'y
	6912330	Main Weight
	6912350	Lateral Weight
	6912370	Bias Weight
54	5105520	SS Type Screw, M2.6×3
55	7082150	Tonearm Guide
56	7082140	Tonearm Lifter Ass'y
57	6502690	Cueing Lever
58	5110241	Hex. Nut, M3
59	5121340	S Type Washer, 3φ
60	5120141	P Type Washer, 3φ
	6622210	Arm Rest Ass'y
61	6622193	Arm Rest
	5232333	Arm Rest Stand
	6412111	Cramp, arm rest
62	5322090	Button, speed selector
63	5312200	Knob, pitch controls
64	5107743	PSB Type Screw, M3×6
65	5151004	E Type Washer, 3φ
66	5120161	P Type Washer, 4φ
67	5182330	P Type Washer, 4φ
68	6012231	Cueing Cam
69	5151004	E Type Washer, 3φ
70	6502680	See-saw Plate
71	5151004	E Type Washer, 3φ
72	5107743	PSB Type Screw, M3×6
73	6902871	Retainer, steel ball
74	6322020	Steel Ball
75	1005200	15kΩ Single Variable Resistor
76	1005190	20kΩ Single Variable Resistor
77	5107847	PSA Type Screw, M3×14
78	1160180	Micro Switch (K-1)
79	5107847	PSA Type Screw, M3×14
80	1160210	Micro Switch
81	5107743	PSB Type Screw, M3×6
82	6902861	Retainer, tonearm lifter
83	6512130	Lever, lifter linkage
84	7022051	Bracket, control block
85	7002080	Control Base Sub Ass'y
	5362360	Name Plate, model
	5362391	Name Plate, control
86	5101043	B Type Screw, M3×6
87	2210210	Terminal Board Ass'y
88	3810190	PU Output Cord
89	7172070	Cabinet Ass'y
	5732354	Cabinet
	6922200	Auto Hinge
	5332022	Badge

1 ~ 30  
 31 ~ 60  
 61 ~ 89

1. Pan Head Tapping Screw ..... PT Type  

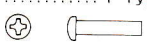

2. Washer Head Tapping Screw ..... WT Type  

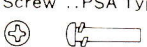
3. Pan Head Screw ..... P Type  

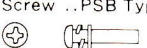
4. Pan Head SEMS A Screw ... PSA Type  

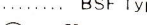
5. Pan Head SEMS B Screw ... PSB Type  

6. Binding Head SEMS F Screw ..... BSF Type  

7. Binding Head Screw ..... B Type  

8. Flat Countersunk Head Screw ..... F Type  

9. Flat Countersunk Wood Screw ..... FC Type  

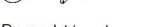

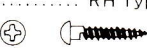
10. Round Head Wood Screw ..... RH Type  

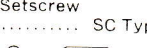
11. Hex. Socket Setscrew ..... SC Type  

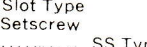
12. Slot Type Setscrew ..... SS Type  

13. Spring Washer ..... S Type  

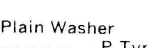
14. Plain Washer ..... P Type  

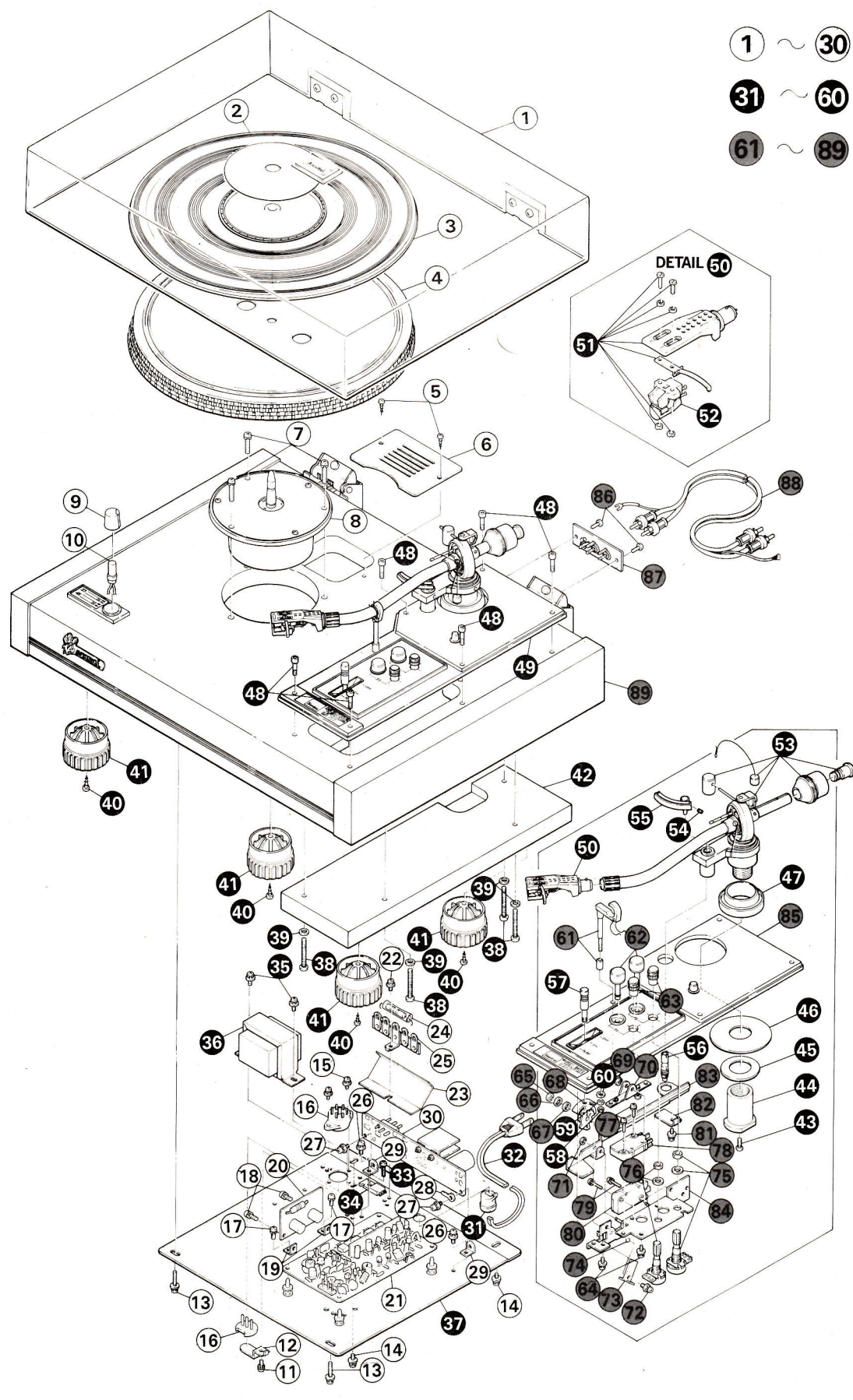

15. Retaining Ring (E Washer) ..... E Type  

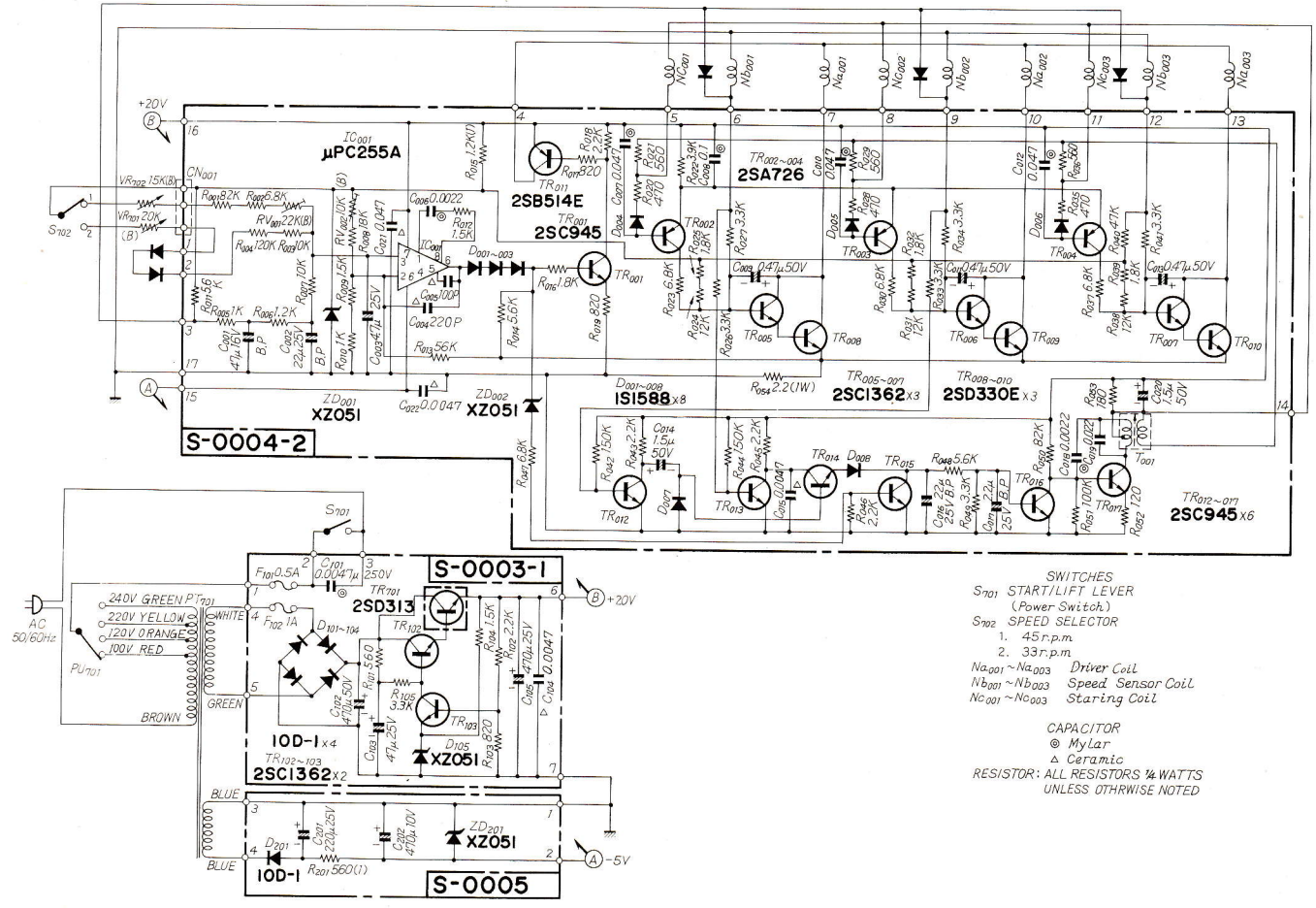

# 4. SCHEMATIC DIAGRAM

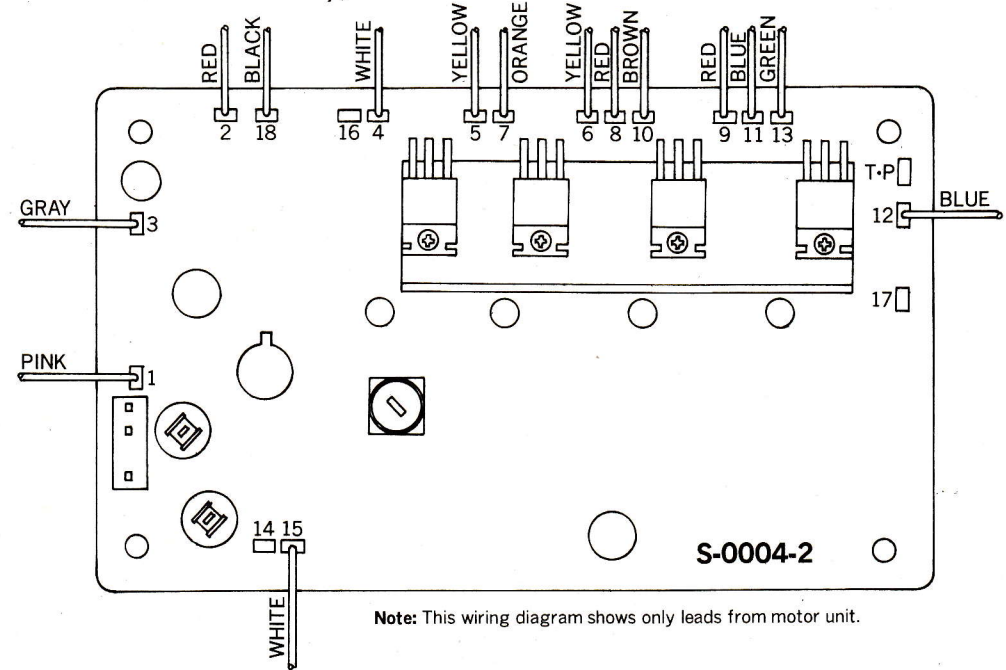

# 5. WIRING (Control Circuit Board Ass'y)



Note: This wiring diagram shows only leads from motor unit.



## 6. ADJUSTMENT (See Fig. 6-1, 6-2, 6-3 and 6-4)

### 6-1. Pre- Adjustment

Basically, any adjustment is unnecessary as RV001 and RV002 on control circuit board, S-0004-2, were exactly adjusted in factory. If necessary, please perform the following steps (See Fig. 6-1).

- 1) Remove the knobs for two Fine Speed Adj. Controls, then turn them to center both 33 and 45r.p.m. (See Fig. 6-2).
- 2) Depress Speed Selector Button for 33r.p.m., then adjust RV002 until the stroboscope shows standstill.
- 3) Depress Speed Selector Button for 45r.p.m., then adjust RV001 until the stroboscope shows standstill as well.

**Note:** To secure the adjustment, perform the 33 r.p.m. speed adjustment first as described above.

Fig. 6-1

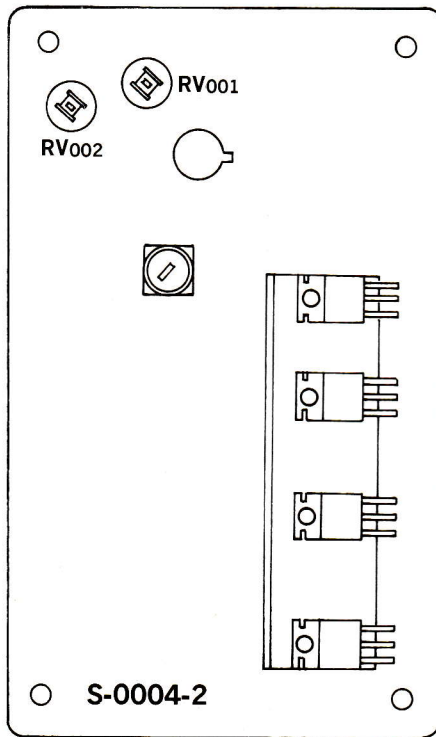
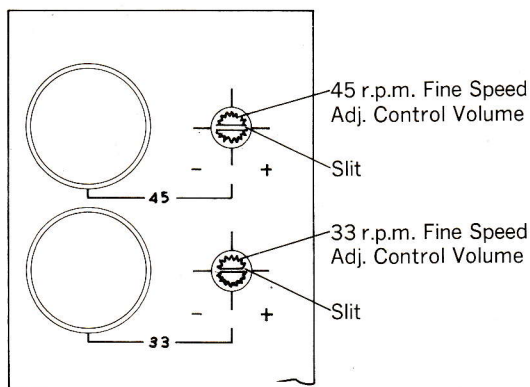

Fig. 6-2



※It is center of the Fine Speed Adj. Control Volume to make the slit of the shaft horizontally.

### 6-2. Fine Adjustment

- 1) How to adjust the speed

To insure an accurate speed, push the Speed Selector Button for 33 $\frac{1}{3}$  r.p.m. or 45 r.p.m. then proceed the Fine speed Adjustment by turning fine speed Adj. Control knob, observing the stroboscope around platter.

Namely,

When turning up the knob to ⊕ (Clockwise), the speed becomes faster.

When turning down the knob to ⊖ (Counterclockwise), the speed becomes slower.

- 2) How to see the stroboscope

There are four patterns showing 50Hz or 60Hz for 33 $\frac{1}{3}$  r.p.m. or 45 r.p.m. respectively.

Please refer to the list below.

Symptom	Speed	Adjustment
1. The Pattern flows to left direction.	Faster	Turn down fine speed Adj. Control knob to ⊖(Counterclockwise)
2. The Pattern flows to right direction.	Slower	Turn up fine speed Adj. Control knob to ⊕(Clockwise)
3. The Pattern shows standstill.	Correct	Any adjustment is not necessary.

Fig. 6-3

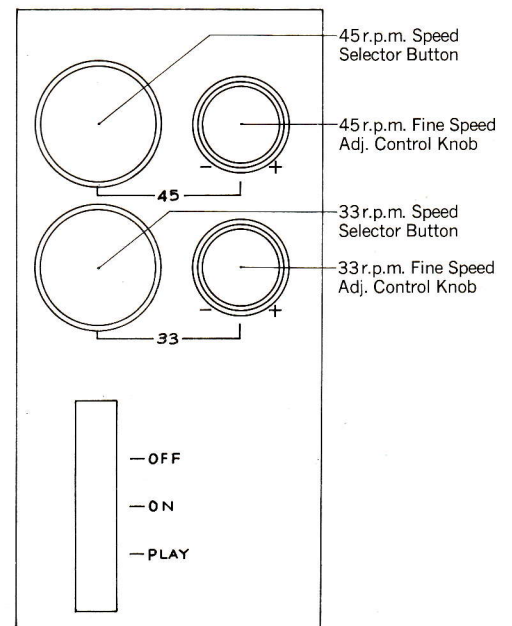
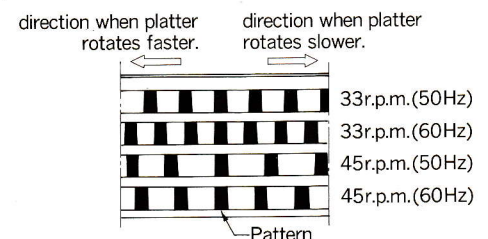
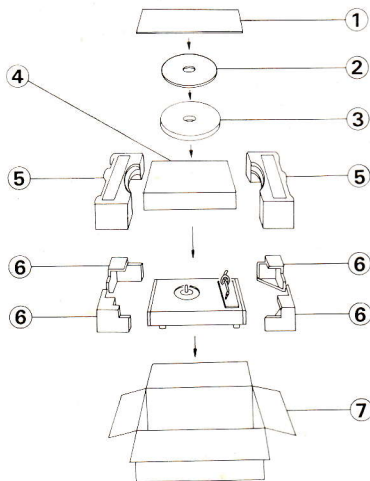

Fig. 6-4



## 7. PACKING LIST

Parts No.	Stock No.	Description
1	9012151	Inner Packing
2	5392110	Turntable Ring
	5502441	Turntable Rubber Mat
3	6112110	Platter
4	7012050	Dust Cover Ass'y
5	9022380	Stylofoam Packing (Top)
6	9022390	Stylofoam Packing (Bottom)
7	9002371	Carton Case



## 8. ACCESSORY PARTS LIST

※Differences between SR-717 and SR-717E

Parts No.	Stock No.	Description
1	6912330	Main Weight
※2		Head Shell Ass'y
		Not Included in SR-717E
※3		Not Included in SR-717
		6642110
4	6172040	45 r.p.m. Adaptor
5	6912340	Sub Weight
6	6912350	Lateral Weight
7	6912370	Bias Weight
8	5242470	Cartridge Mounting Gauge
	9202230	Operating Instructions

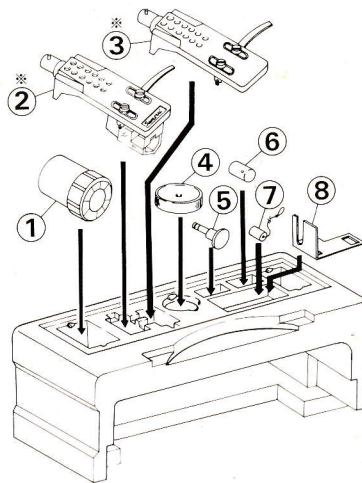

**Sansui**

SANSUI ELECTRIC CO., LTD.

14-1, 2-chome, Izumi, Suginami-ku, Tokyo 168, Japan  
TELEPHONE: (03) 323-1111/TELEX: 232-2076

SM025

Printed in Japan (84830M)