

SERVICE MANUAL

TWO-SPEED DIRECT-DRIVE TURNTABLE

SANSUI SR-525

HILBERINK
Electronics-Acoustics
P.O. Box 4217
6202 WB MAASTRICHT
The Netherlands



Sansui

SANSUI ELECTRIC CO., LTD.

Notice:

In this service manual, some parts have four types, A, B, C and D in same parts No. as shown in Parts List. Each type can be indentified from Mark on the carton case as Fig. 1.

- TYPE A SR-525
- TYPE B SR-525E
- TYPE C SR-525P
- TYPE D (Do not use the parts in type D as they are not applicable for this model).

Type	Mark
Type A	No mark
Type B	Mark ⓔ
Type C	Mark Ⓟ

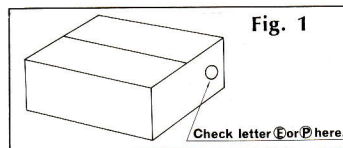

*When ordering parts, please use parts name and the stock No. referring to Parts List.

1. SPECIFICATIONS

TYPE Two-speed direct-drive
 SPEEDS 33 1/3 and 45 rpm
 FINE SPEED ADJUSTMENT RANGE ±3.5%
 PLATTER Aluminum alloy die-cast
 31cm (12-1/4") diameter,
 1.4 kg (3.1 lbs.)
 MOTOR 20-pole
 brushless DC servo-type
 WOW & FLUTTER less than 0.03% (W.R.M.S.)
 S/N better than 60dB
 TONEARM Statically-balanced S-shaped
 tubular
 TONEARM LENGTH 220mm (8-11/16")
 OVERHANG 17.5mm (3/4")
 SUITABLE CARTRIDGE WEIGHT 4 to 11 g
 CARTRIDGE (only for units purchased in areas other than U.S.A.,
 Canada and Europe) .. Moving magnet-type (Model
 SV-27A)

OUTPUT VOLTAGE 3.5mV (1,000Hz, 50mm/sec.)
 OPTIMUM LOAD IMPEDANCE 47kΩ
 FREQUENCY RESPONSE 10Hz to 23 kHz
 OPTIMUM TRACKING FORCE 1.5 to 2.0 g
 STYLUS diamond, 0.5 mil (Model
 SN-27)
 POWER REQUIREMENTS 100, 120, 220, 240V, 50/60Hz
 120V (Usable 110-130V), 60Hz
 (U.S.A. & Canada only)
 POWER CONSUMPTION 5W (rated)
 DIMENSIONS 469mm (18-1/2")
 150mm (5-15/16") H
 375mm (14-13/16") D
 WEIGHT 9.5kg (20.9 lbs.) Net
 11.2kg (24.6 lbs.) Packed

* Design and specifications subject to change without notice for improvements.

TABLE OF CONTENTS

<u>Section</u>	<u>Title</u>	<u>Page</u>
1.	SPECIFICATIONS	1
2.	PARTS LOCATIONS AND PARTS LISTS	2
2-1.	S-0006 Power Supply Circuit Board	2
3.	DISASSEMBLY WITH EXPLODED VIEWS, PARTS LOCATIONS	3, 4
4.	ADJUSTMENTS	5
4-1.	Pre-Adjustment	5
4-2.	Fine Adjustment	5
5.	SCHEMATIC DIAGRAM	6
6.	PACKING LIST	7
7.	ACCESSORY PARTS LIST	7

2. PARTS LOCATIONS AND PARTS LISTS

* In Parts List above, there are four types A, B, C and D in same parts No.
When ordering parts, please refer to Notes indicated in page 1.

2-1. S-0006 Power Supply Circuit Board (Stock No. 7501180 Complete Circuit Board... Type A, B, D) Counductor Side (Stock No. 7501190 Complete Circuit Board... Type C)

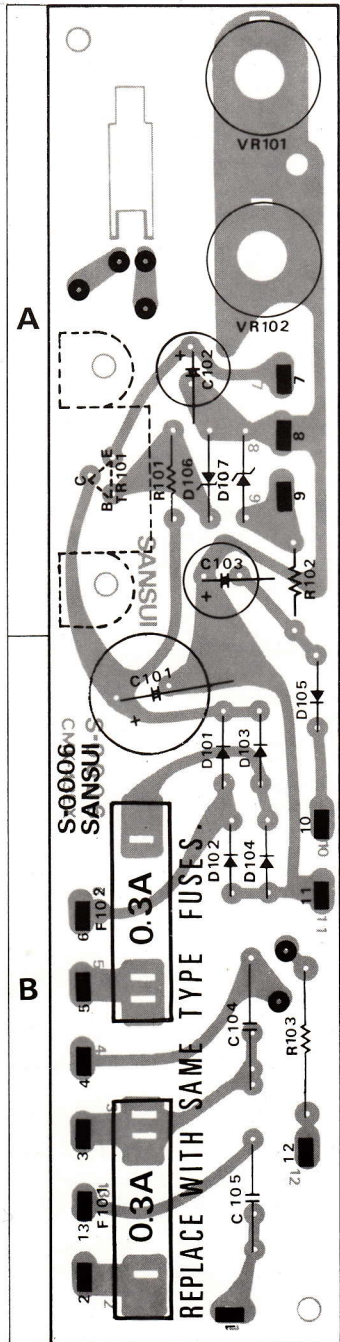

Parts List

Parts No.	Stock No.	Description	Position
TR101	0308392	2SD313 (E, F) Transistor	A
D101	0310340	10D-1	B
D102	0310340	10D-1	B
D103	0310340	10D-1	B
D104	0310340	10D-1	B
D105	0310340	10D-1	B
D106	0315360	RD-19AK	A
D107	0316380	XZ-051	A
C101	0515331	330 μ F 50V	B
C102	0513101	100 μ F 25V	A
C103	0511221	220 μ F 10V	A
C104	0605107	0.01 μ F 250V M.C.	B
R101	0107332	3.3k Ω 1/4W C.R.	A
R102	0114561	560 Ω 1/2W C.R.	A
R103	0104123	12k Ω 1W C.R.	B
F101	{0430810 0431210}	0.5A 250V (Type A, B, D) 0.5A 250V (Type C)	B
F102	{0430810 0431210}	0.5A 250V (Type A, B, D) 0.5A 250V (Type C)	B
VR101	1005240	2k Ω	A
VR102	1005250	3k Ω	A
NL101	0410090	Neon Lamp	
	5932010	Heat Sink	

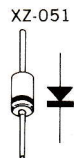
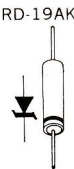
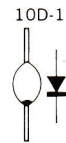
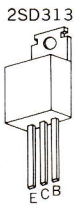

Abbreviations

C.R.	: Carbon Resistor	BP.E.C.:	Bi-Polar Electrolytic Capacitor
S.R.	: Solid Resistor	C.C.	: Ceramic Capacitor
Ce.R.	: Cement Resistor	Mi.C.	: Mica Capacitor
M.R.	: Metallized Film Resistor	O.C.	: Oil Capacitor
M.C.	: Mylar Capacitor	P.C.	: Polystyrene Capacitor
E.C.	: Electrolytic Capacitor	E.C.	: Tantalum Capacitor

HILBERINK
Electronics-Acoustics
P.O. Box 4217
6202 WB MAASTRICHT
The Netherlands

3. DISASSEMBLY WITH EXPLODED VIEWS, PARTS LOCATIONS

Parts List

* In Parts List above, there are four types A, B, C and D in Same parts No.
When ordering parts, please refer to Notes indicated in Page 1.

Parts No.	Stock No.	Description
1	7012060	Dust Cover Ass'y
	5362401	Name Plate
	6922250	Lock Plate
	5109563	B Type Screw, M4×10
	5502490	Rubber Cushion
2	7292110	Rubber Mat Ass'y
		{ Turntable Ring
		{ Rubber Mat, turntable
3	6112120	Turntable (Platter)
4	5109906	BSB Type Screw, M4×16
5	4320340	Motor
6	5312210	Knob, pitch controls
7	5312220	Button, Speed Selector
8	5362411	Control Base
9	5422010	Strobo Lens
10	5109905	WT Type Screw, M3×12
11	5103541	PT Type Screw, M3×6
12	2120010	Lug Terminal
13		Bottom Cover, tonearm
14		Hex. Nut, tonearm
15	5182480	Wave Washer
16	5182470	Special Washer (2), tonearm
17	5182460	Special Washer (1), tonearm
18	7092370	Tonearm Ass'y
	6912400	Main Weight
	6912380	I.F.C Ass'y
	7082170	Arm Lifter Ass'y
	7092360	Arm Base
	6912390	Lateral Weight Ass'y
19	5109905	WT Type Screw, M3×12
20	5512110	Insulator (A)
21	5512101	Insulator
22	5107852	PSA Type Screw, M3×8.....Type A, B, D Not Included in Type C
23	2410890	Voltage Selector, Socket.....Type A, B, D Not Included in Type C
24	2410820	Voltage Selector, plug.....Type A, B, D Not Included in Type C
25	3910490	Cord Stopper
26	3800261	Power Cord.....Type A, B, D
	3800030	Power Cord.....Type C
27		Bracket, voltage selector.....Type A, B, D Not Included in Type C
28	5022042	Bottom Cover.....Type A, B, D
	5022032	Bottom Cover.....Type C
29	5110261	Hex. Nut, M4
30	5221360	S Type Washer, 4φ
31	5120161	P Type Washer, 4φ
32	5107851	PSA Type Screw, M3×25
33	5120141	P Type Washer, 3φ
34	5140440	RH Type Screw, M3.5×32
35	5392140	Lever Guide (A)
36	5107852	PSA Type Screw, M3×8
37	1171020	Lever Switch Ass'y
	5103046	P Type Screw, M3×12
	5121340	S Type Washer, 3φ
	1160180	Micro Switch (K-1)

Parts No.	Stock No.	Description
38		Retainer, Speed Selector Switch
39	5107769	PSB Type Screw, M4×25
40	4002310	Power TransformerType A, B, D
	4002312	Power TransformerType C
41	5100243	B Type Screw, M3×6
42	5222260	Bracket, Power Supply Circuit board Ass'y
43	7501170	Power Supply Circuit Board (A)..Type A,B,D
	7501190	Power Supply Circuit Board (C)..Type C
44	5732382	Wood Retainer (B)
45	5109905	WT Type Screw, M3×12
46	6922240	Auto Hinge
47	2210300	2P Input Terminal Ass'y
48	3810220	PU Output Cord
49	7172110	Cabinet Ass'y.....Type A, B, C
	7172120	Cabinet Ass'y.....Type D
	5332040	Badge
	5362421	Name PlateType A, B, C
	5362460	Name PlateType D

Abbreviations

- | | |
|--|--|
| 1. Pan Head Tapping ScrewPT Type
 | 10. Round Head Wood ScrewRH Type
 |
| 2. Washer Head Tapping ScrewWT Type
 | 11. Hex. Socket Setscrew...SC Type
 |
| 3. Pan Head ScrewP Type
 | 12. Slot Type Setscrew...SS Type
 |
| 4. Pan Head SEMS A ScrewPSA Type
 | 13. Binding Head SEMS B ScrewBSB Type
 |
| 5. Pan Head SEMS B ScrewPSB Type
 | 14. Spring WasherS Type
 |
| 6. Binding Head SEMS F Screw ..BSF Type
 | 15. Plain WasherP Type
 |
| 7. Binding Head ScrewB TYPE
 | 16. Retaining Ring (E Washer)..E Type
 |
| 8. Flat Counter Sunk Head Screw..F Type
 | 17. Toothed Lock Washer (External)TLE Washer
 |
| 9. Flat Counter Sunk Wood ScrewFC Type
 | |

1 ~ 25

26 ~ 49

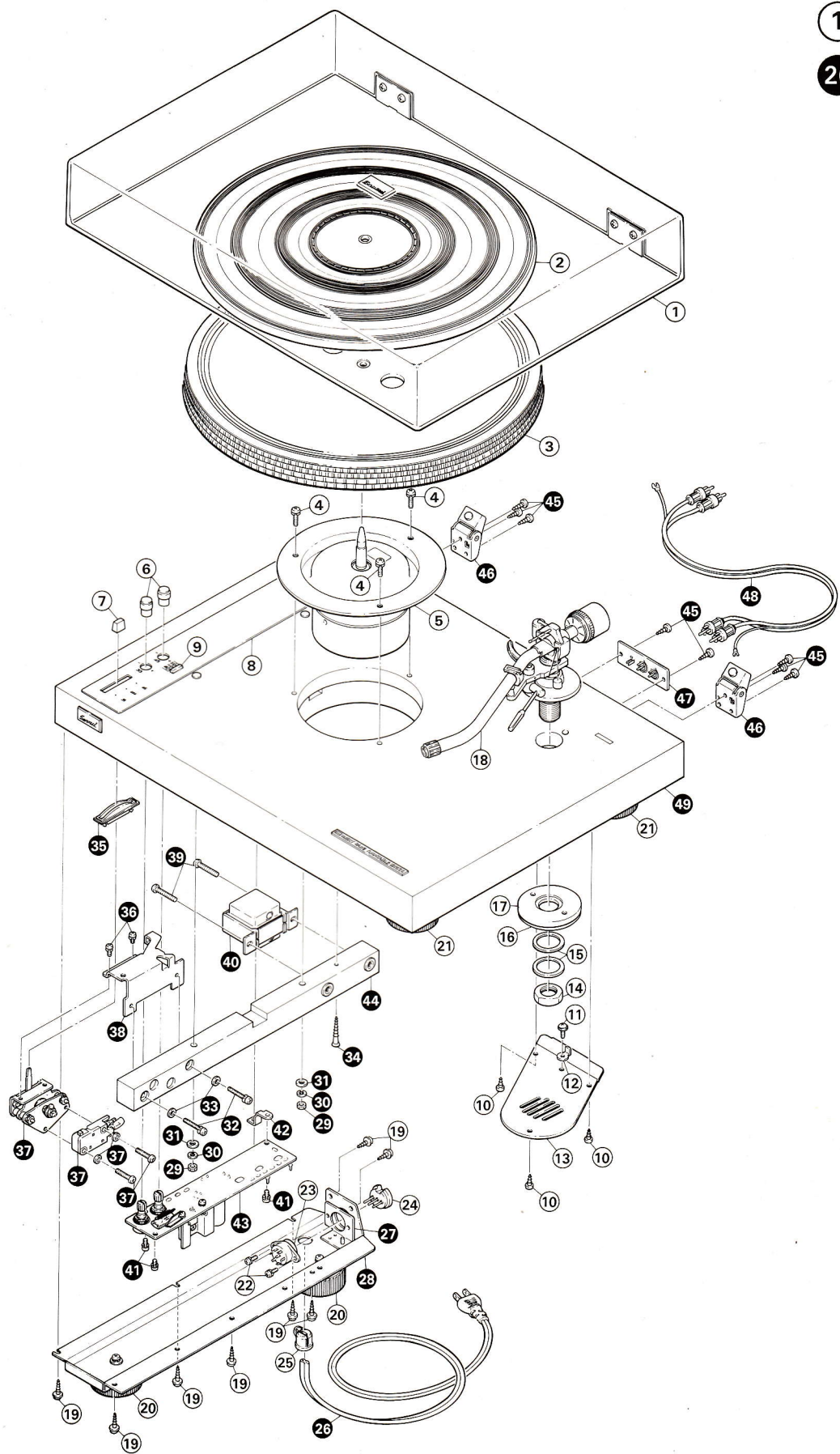

4. ADJUSTMENTS

4-1. Pre-Adjustment

Pre-Adjustments for 33 & 45 r.p.m are unnecessary, as the speed adjustment volumes on bottom side of motor were exactly adjusted in factory. When necessary, please perform the following steps.

- 1) Remove the Knobs for two Fine Speed Adj. Controls, then turn them to center both 33 & 45 r.p.m (See Fig. 4-1).
- 2) Depress Speed Selector Button for 45 r.p.m, then adjust the volume for 45 r.p.m speed adjustment on bottom side of motor (Fig. 4-2) until the strobo scope shows standstill.
- 3) Then depress Speed Selector Button for 33 r.p.m, and adjust the volume for 33 r.p.m speed adjustment on bottom side of motor until the strobo scope shows standstill.

Note: ① To ensure the adjustment, perform the 45 r.p.m speed adjustment first.

② For adjusting two speeds, use small screw driver covered by vinyl tube or plastic driver to avoid short circuit.

Fig. 4-1

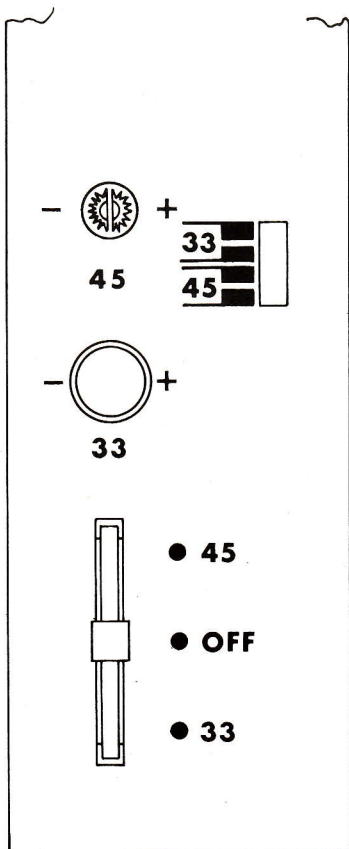

Note: It is center of the Fine Speed adj. control volume to make the slit of the shaft hollizontally.

4-2. Fine Adjustment

1) How to adjust the speed

To insure an accurate speed, push the Speed Selector Button for 33 $\frac{1}{2}$ r.p.m. or 45 r.p.m. then proceed the Fine speed Adjustment by turning fine speed Adj. Control knob, observing the stroboscope around platter.

Namely,

When turning up the knob to ⊕ (Clockwise), the speed becomes faster.

When turning down the knob to ⊖ (Counterclockwise), the speed becomes slower.

2) How to see the stroboscope

There are four patterns showing 50Hz or 60Hz for 33 $\frac{1}{2}$ r.p.m. or 45 r.p.m. respectively.

Please refer to the list below.

Symptom	Speed	Adjustment
1. The Pattern flows to left direction.	Faster	Turn down fine speed Adj. Control knob to ⊖ (Counterclockwise)
2. The Pattern flows to right direction.	Slower	Turn up fine speed Adj. Control knob to ⊕ (Clockwise)
3. The Pattern shows standstill.	Correct	Any adjustment is not necessary.

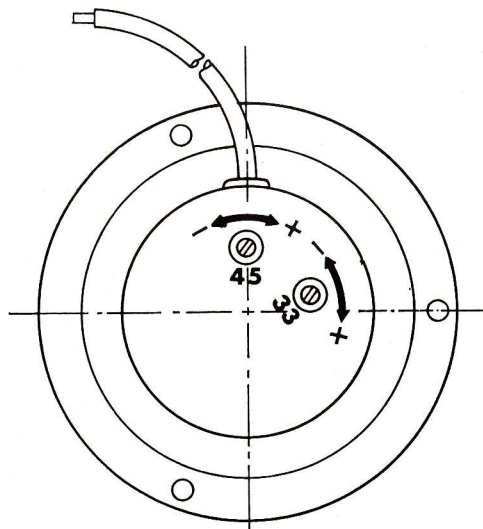
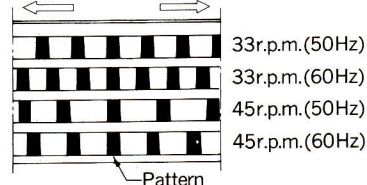
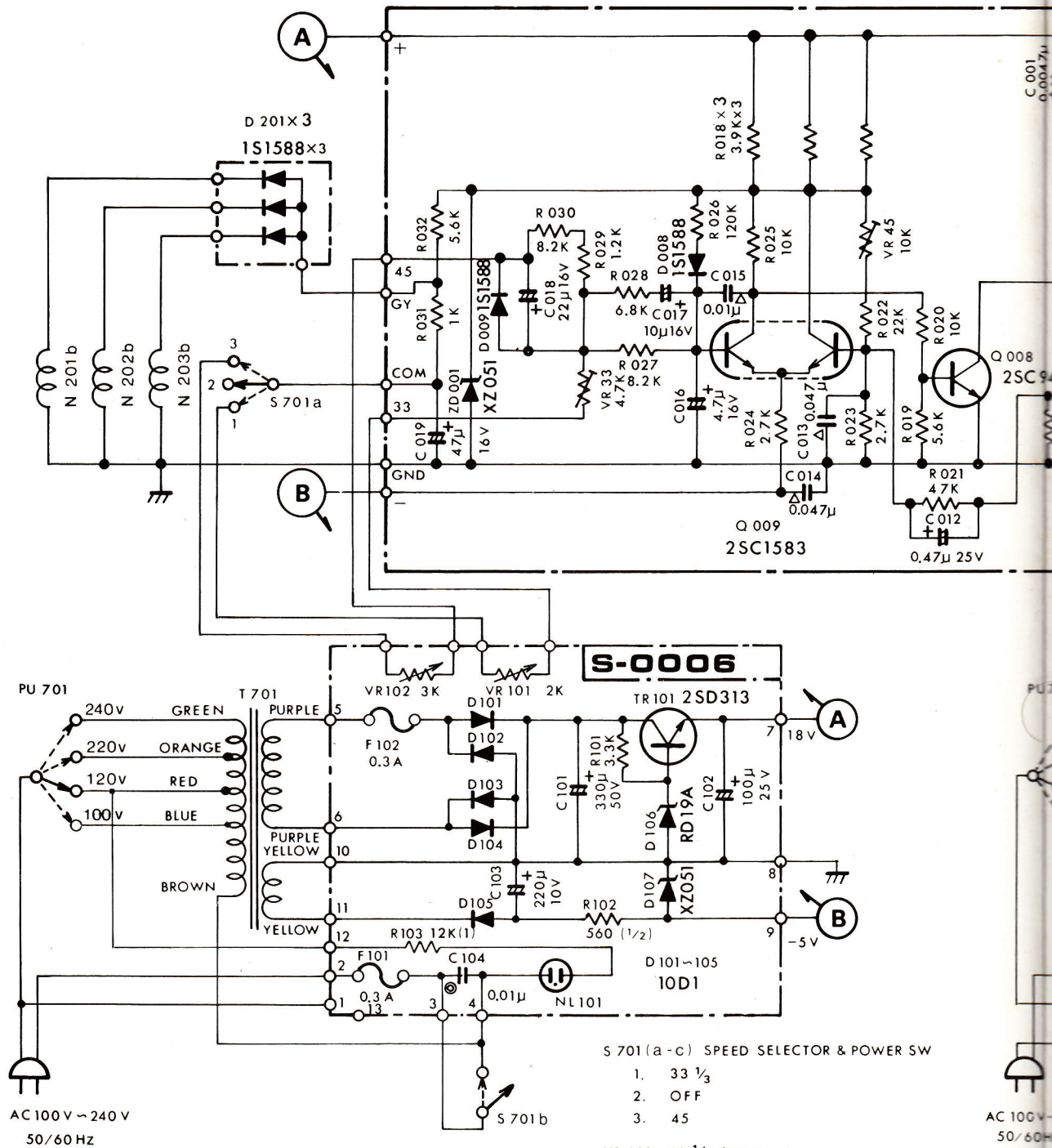

Fig. 4-2 Bottom side of Motor

Fig. 4-3 direction when platter rotates faster. direction when platter rotates slower.



5. SCHEMATIC DIAGRAM



S 701 (a - c) SPEED SELECTOR & POWER SW

1. 33 1/3
2. OFF
3. 45

VR 101. 33 1/3 SPEED ADJ.
VR 102. 45 SPEED ADJ.

CAPACITOR
 ● MYLAR
 ▲ CERAMIC

RESISTOR: ALL RESISTORS 1/4 WATTS
UNLESS OTHERWISE NOTED

* La présentation et les spécifications sont susceptibles d'être modifiées sans préavis par suite d'améliorations éventuelles.
 * Änderungen, die dem technischen Fortschritt dienen, bleiben vorbehalten.
 * Design and specification subject to change without notice for improvements.

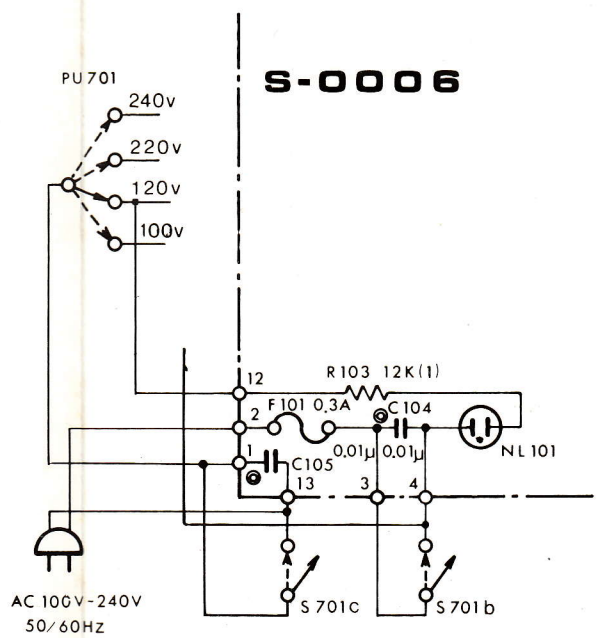
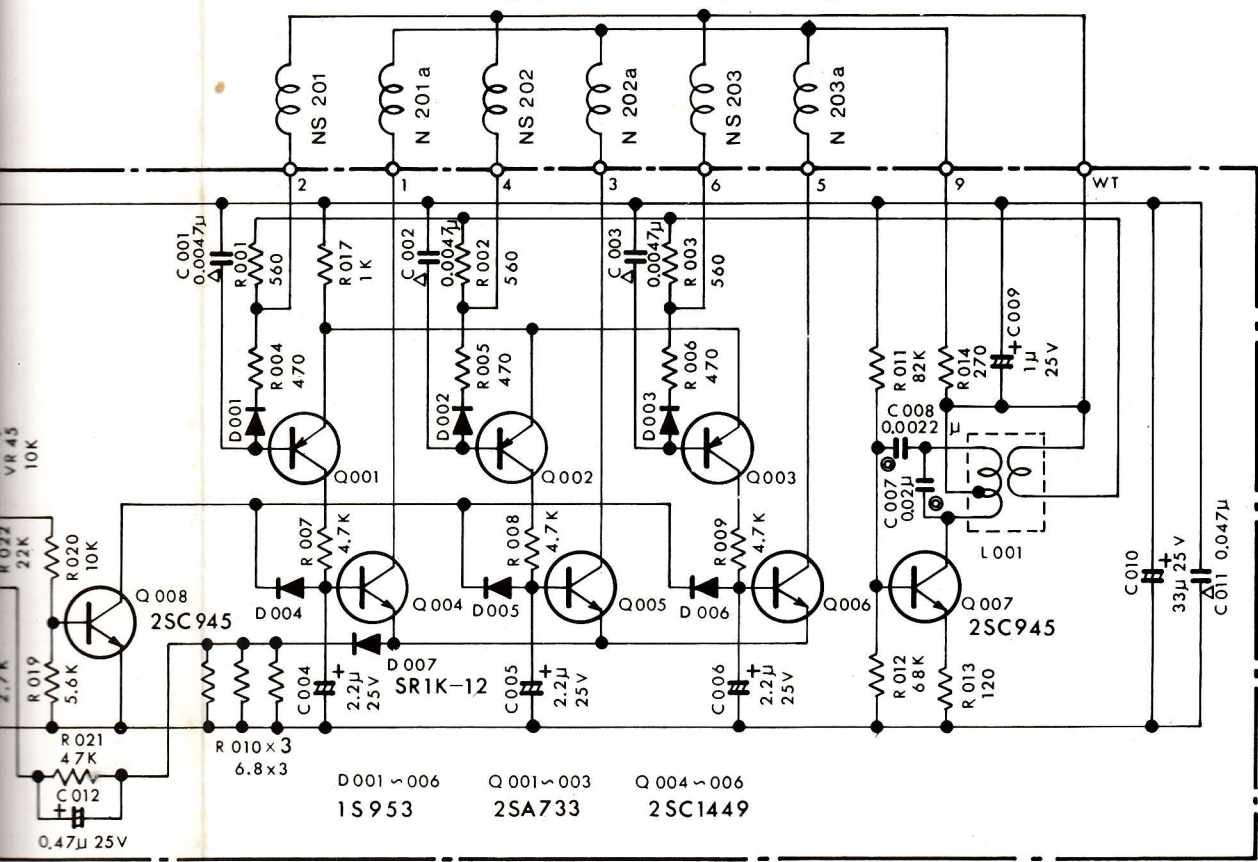

EU Model Only.

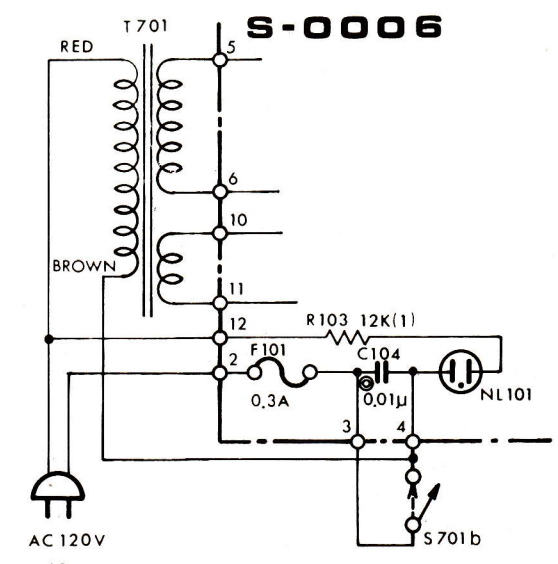

UL & CSA Model Only.

6. PACKING LIST

* In Parts List above, there are four types A, B, C and D in same Parts No. When ordering parts, please refer to Notes indicated in page 1.

Parts No.	Stock No.	Description
1	9012190	Inner Packing
2	9116600	Vinyl Cover
3	7292110	Rubber Mat Ass'y
4	7012060	Dust Cover Ass'y
	9122012	Polystyrene Sheet
	9012200	Packing (For Dust Cover)
	9022450	Stylofoam Packing A (For Dust Cover)
5	9082010	Accessory Parts Box and Tonearm packing
6	9022430	Stylofoam Packing
7	9122030	Poryethylene Cover
8	{9002510	Carton Case.Type A, B, C
	{9002461	Carton Case.Type D
	9202280	Operating Instructions.Type A, B, C
	9202310	Operating Instructions.Type D

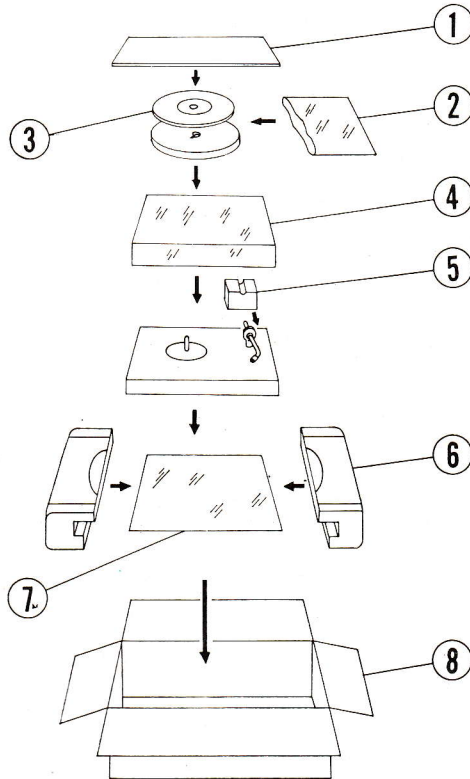

7. ACCESSORY PARTS LIST

* In Parts List above, there are four types A, B, C and D in same Parts No. When ordering parts, please refer to Notes indicated in page 1.

Parts No.	Stock No.	Description
1	5242470	Cartridge Mounting Gavage
2	6172040	45r.p.m Adaptor
3	6912400	Main Weight
4	5192080	Hexagon Wrench
5		Bias Weight
6		Head Shell Ass'y (Not Included in Type B, C)
	{6642130	Head Shell Sub Ass'y (Not Included in Type A, D)
	{4310300	Cartridge (Not Included in Type B, C)
	{4940160	Stylus (Not Included in Type B, C)
		Stylus Cover (Not Included in Type B, C)
7	9082010	Accessory Parts Box
	9392640	Caution Sheet (Into the Accessory Parts Box)
	9022490	Accessory Parts Box Lid

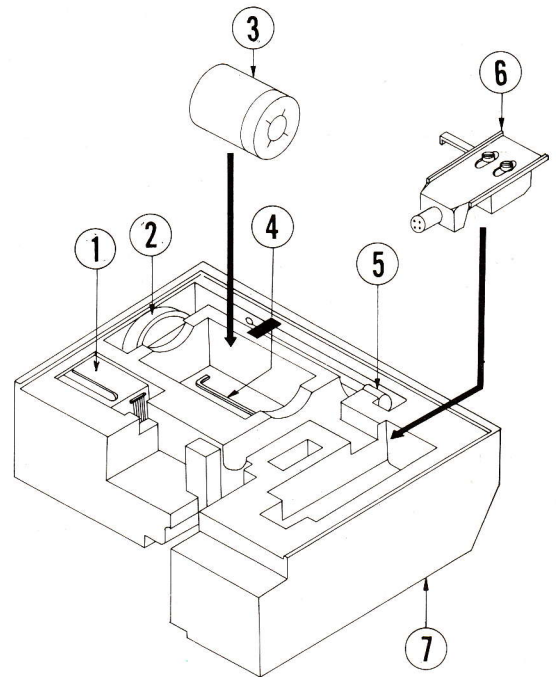



SANSUI ELECTRIC CO., LTD.
14-1, 2-chome, Izumi, Suginamiku, Tokyo 168, Japan.
TELEPHONE: (03) 323-1111 / TELEX: 232-2076

SM042

Printed in Japan (N5620M)