



Technical Manual

FM STEREO TUNER RHT10

TABLE OF CONTENTS

- Chassis Layout..... 1
- Specifications..... 2
- Block Diagram..... 3
- Adjustment..... 4
- PC Board Ass'y Parts List..... 6
- Schematic Diagram..... 12
- Wiring Diagram..... 16
- Printed Circuit Board..... 18

THE ROTEL CO., LTD.
 1-36-8, OHOKAYAMA, MEGURO-KU, TOKYO 152, JAPAN
ROTEL ELECTRONICS CO., LTD.
 3F-2, NO.35, FU HSING NORTH ROAD, TAIPEI, TAIWAN, REPUBLIC OF CHINA

Chassis Layout

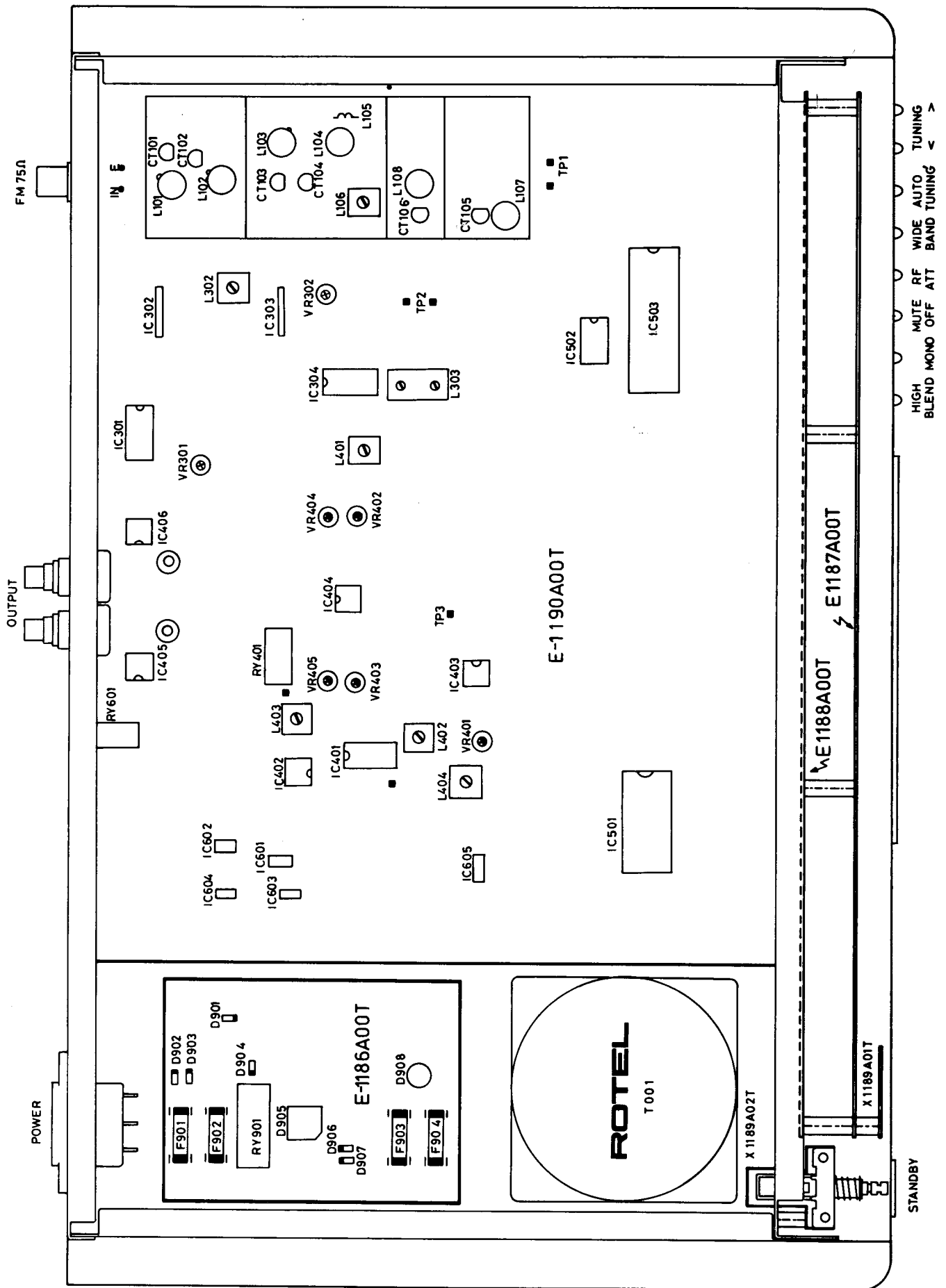

Specifications

Frequency Range	87.5 to 108 MHz
Antenna Input Impedance.....	75 ohms unbalanced
Usable Sensitivity	
Mono (Wide).....	10.8 dBf (0.95 μ V) at 75 ohms
(Narrow)	17.2dBf (2 μ V) at 75 ohms
50 dB Quieting Sensitivity:	
Mono	14.8 dBf (1.5 μ V) at 75 ohms
Stereo	37.2 dBf (20 μ V) at 75 ohms
Capture Ratio	1.0 dB
Alternate Channel Selectivity:	
Wide.....	60 dB
Narrow.....	80 dB
Adjacent Channel Selectivity	25 dB (Narrow) <i>5 to 6 dB wide.</i>
Spurious Response Ratio	100 dB
Image Response Ratio	80 dB
IF Response Ratio	100 dB
AM Suppression Ratio	60 dB
Sub carrier Product Ratio	60 dB
SCA Rejection Ratio.....	70 dB
Muting Threshold.....	18 μ V
Output Level.....	1.5 Vrms
Frequency Response.....	30 to 15,000 Hz \pm 0.5 dB
Signal to Noise Ratio (at 65 dBf):	
Mono	87 dB
Stereo	82 dB
Harmonic Distortion (at 65 dBf, Wide):	
Mono	0.05 % at 1 kHz
Stereo	0.1 % at 1 kHz
Stereo Separation:	
100 Hz.....	45 dB
1 kHz.....	50 dB
10 kHz.....	40 dB
De-emphasis	50 μ S (Europe), 75 μ S (Americas)
Power Requirement.....	120V, 230V or 240V, 50/60Hz
Power Consumption	12 W
Overall Dimensions	470(w) x 76 (h) x 332 (d) mm
	18 1/2"(w) x 3"(h) x 13 1/16"(d)
Net Weight	5.5 kg/ 12.1 lbs

NOTE: Specifications and design are subject to possible modification without notice.

Block Diagram

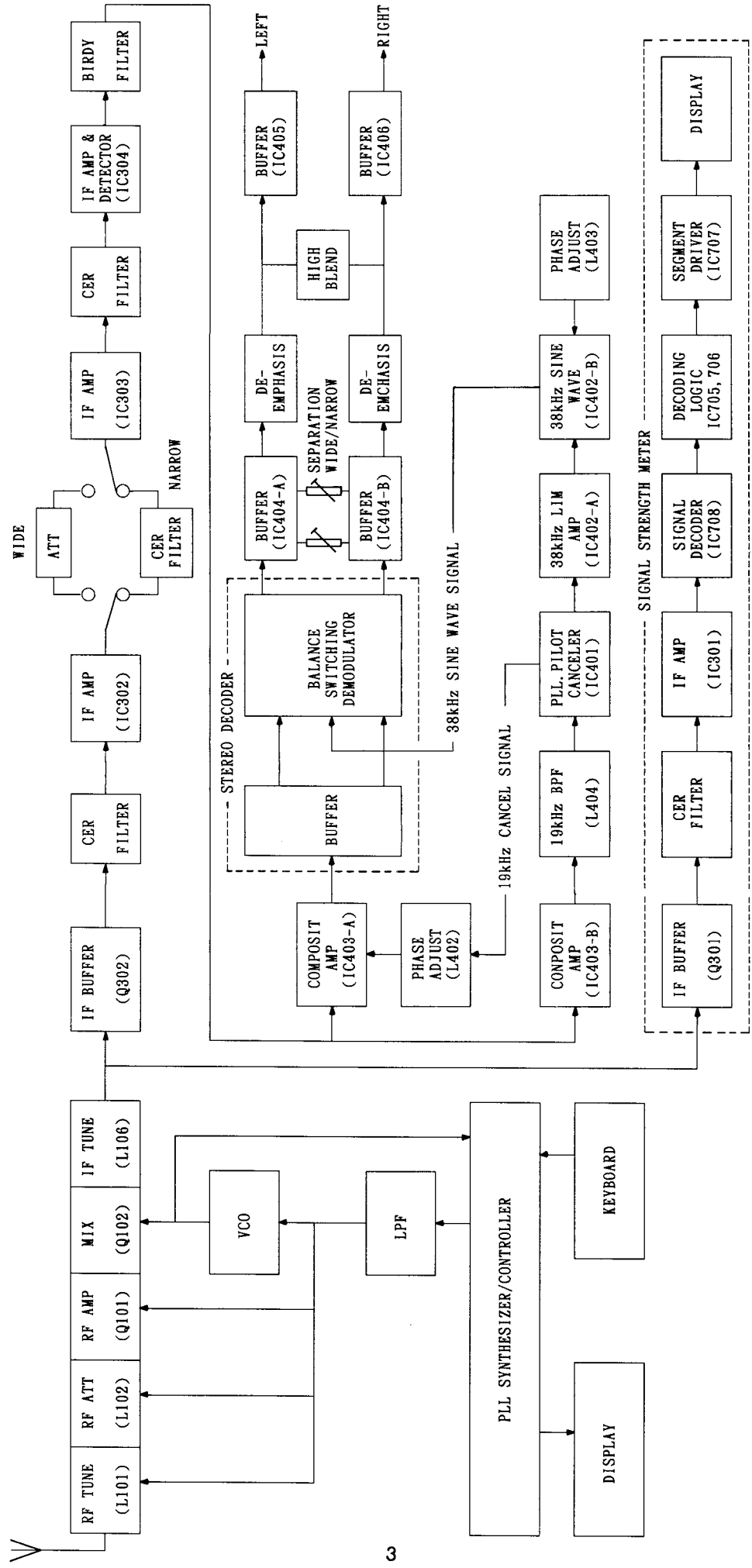

FM IF and RF Alignment

Instruments: FM Signal Generator (400Hz,100% Modulated), THD Analyzer, Oscilloscope, AC VTVM, DC Voltmeter, Tuning Meter.

Test point : DC Voltmeter---Between TP1 and Earth on 016E1190A00T P.C.B.
Tuning Meter---Between TP2 A and B on 016E1190A00T P.C.B.

Step	Generator		Tuning Dial Setting	Adjust	Adjust for
	Coupling	Frequency			
1	N/A		87.5 MHz	L107	3V reading on DC Voltmeter
2			108 MHz	CT105	22V reading on DC Voltmeter
3	Repeat steps 1 and 2 unit until no further improvement is noticed.				
4	Antenna terminal	90 MHz	90 MHz	L101,102 L103,104 L107,108	Maximum reading on AC VTVM.
5		105 MHz	105 MHz	CT101- CT104 CT106	Maximum reading on AC VTVM.
6	Repeat steps 4 and 5 unit until no further improvement is noticed. (muting OFF) (RFF ATT ON)				
7	Antenna terminal 1mV input	90 MHz	90 MHz	L303(A)	Adjust center on Tuning Meter
8				L303(B)	Minimum reading on THD Analyzer
9	Repeat steps 7 and 8 unit until no further improvement is noticed. (Muting OFF)				
10	Antenna terminal 5uV input	90 MHz	90 MHz	VR302	Muting Level (Muting ON)
11	Antenna terminal 1mV input	90 MHz	90 MHz	VR301	Signal Indicator Level To "7" (Muting OFF)

FM MPX Alignment

Instruments: FM Stereo Generator, AC VTVM, Oscilloscope.

Test point : When adjust pilot cancel---Between TP3 and Earth
on 016E1190A00T P.C.B.

Step	Generator		Tuning Dial Setting	Adjust	Adjust for
	Coupling	Frequency			
1	Antenna terminal 1mV input	98 MHz Mod Pilot--10% 1 kHz--90% Sub signal (L or R)	98 MHz	L403 L404	VCO 76kHz+/-100Hz Maximum reading on AC VTVM at output.
2		98 MHz Mod Pilot--10%		VR401 L402	Pilot cancel Minimum reading on AC VTVM at TP3.
3		98 MHz Mod Pilot--10% 1 kHz--90% (L or R)		VR402 VR403	Separation (Wide) Minimum reading on AC VTVM at output.
4				VR404 VR405	Separation (Narrow) Minimum reading on AC VTVM at output
Note	It will be better to use 38 KHz low pass filter when adjust Separation.				

CHANGING THE FM BAND FOR DIFFERENT MARKETS

	J501	FREQUENCY RANGE	TUNING INTERVAL
USA	OPEN	87.5 MHz—108 MHz	100 kHz
EUROPE UK	CLOSE	87.5 MHz—108 MHz	50 kHz

PRESETTING FM DE-EMPHASIS

	J401, J402	DE-EMPHASIS
USA	CLOSE	75 μ S
EUROPE UK	OPEN	50 μ S

PRESETTING FM MUTING (AUTO-STOP) LOCK RANGE

	J301	LOCK RANGE
USA	CLOSE	\pm 70 kHz
EUROPE UK	OPEN	\pm 30 kHz

Parts List

NOTE: THE COMPONENTS INDENTIFIED BY Δ MARK ARE FOR SAFETY. REPLACE ONLY WITH ORIGINAL PARTS. DO NOT SUBSTITUTE.

SYMBOL	PARTS NO.	DESCRIPTION
E-1186A00T PCB ASSEMBLY		
R901, 902	RM81002616	R, METAL MK2010KFECZ.
R903	RM84752616	R, METAL MK247K5FECZ.
C901	CC01009256	CAP, CERAMIC 0.01uF 250V Δ
C902	CE01007504	CAP, ELEC. 1uF 50V
C903, 904	CC01009256	CAP, CERAMIC 0.01uF 250V Δ
C905	CE04705358	CAP, ELEC. 470uF 35V
C906-909	CC01009256	CAP, CERAMIC 0.01uF 250V Δ
C910, 911	CE64704449	CAP, ELEC. LGS1H472MHS
C912	CE02205449	CAP, ELEC. 220uF 63V
C913, 914	CC01009256	CAP, CERAMIC 0.01uF 250V Δ
C915	CE02205449	CAP, ELEC. 220uF 63V
C916-919	CC01009256	CAP, CERAMIC 0.01uF 250V Δ
C920	CE04705164	CAP, ELEC. 470uF 16V
D901-904	DD1000068	DIODE IN4003
D905	DD10000380	DIODE BR-64
D906, 907	DD1000068	DIODE IN4003
D908	DD10000123	DIODE W02
RY901	LY00000289	RELAY VB-24SMCU-E Δ
F901, 902	FU25000077	FUSE 250V T1A UL/CAS Δ
	FU23000207	FUSE 250V T1A S Δ
Q901	TR10000059	TRANSISTOR 2SB764E/F
E-1187A00T PCB ASSEMBLY		
R801	RM81002616	R, METAL MK2010KFECZ.
R802	RM84752616	R, METAL MK247K5FECZ.
R803	RM81002616	R, METAL MK2010KFECZ.
R804-812	RM81211618	R, METAL MK21K21FECZ.
R813-817	RM84752616	R, METAL MK247K5FECZ.
R818	RM81212611	R, METAL MK212K1FECZ.
R819	RM81002616	R, METAL MK2010KFECZ.
R820-823	RM82212618	R, METAL MK222K1FECZ.
R824-827	RM81001612	R, METAL MK2001KFECZ.
R828	RM81002616	R, METAL MK2010KFECZ.
R829, 830	RM82212618	R, METAL MK222K1FECZ.
R831, 832	RM81001612	R, METAL MK2001KFECZ.
R833, 834	RM86812616	R, METAL MK268K1FECZ.
R835-841	RM81211618	R, METAL MK21K21FECZ.
C801-806	CC31009465	CAP, CERAMIC 0.01uF 50V
C807, 808	CY21008428	CAP, LAYER 50MSA104J
C809, 810	CC31009465	CAP, CERAMIC 0.01uF 50V
D801-806	DD40001245	LED LN21RPH
D807, 808	DD80000021	DIODE IN4148
Q801	TR30000327	TRANSISTOR 2SC536G-NP
Q802	TR10000126	TRANSISTOR 2SA608KF
Q803, 804	TR30000327	TRANSISTOR 2SC536G-NP
FL801	DD40000976	FL TUBE FIP7F8S
D809-811	DD40001233	LED LN513RK
IC801	IC00002740	uPD4511BAC
IC802	IC00002107	TC9130P
S801-808	SH60000252	KEY BOARD SW 4TR-2627
E-1188A00T PCB ASSEMBLY		
R701	RM34702085	THICK FILM RS NETWORK RAB-473-8K
R709-715	RM84752616	R, METAL MK247K5FECZ.
R716	RM81502613	R, METAL MK2015KFECZ.
R717, 718	RM81002616	R, METAL MK2010KFECZ.
R719	RM81502613	R, METAL MK2015KFECZ.
R720	RN34702085	THICK FILM RS NETWORK RAB-473-8K
R728-733	RM81002616	R, METAL MK2010KFECZ.
R734	RM82212618	R, METAL MK222K1FECZ.
R735-737	RM81002616	R, METAL MK2010KFECZ.
R738-740	RM84752616	R, METAL MK247K5FECZ.
R741-743	RM81002616	R, METAL MK2010KFECZ.
R747	RN32202081	THICK FILM RS NETWORK SE8223JFU

SYMBOL	PARTS NO.	DESCRIPTION
R752	RN32202068	THICK FILM RS NETWORK SE6223JFU
R758	RN32202081	THICK FILM RS NETWORK SE8223JFU
C701-704	CC31009465	CAP, CERAMIC 0.01uF 50V
C705	CE01007504	CAP, ELEC. 1uF 50V
C706	CE04706168	CAP, ELEC. 47uF 16V
C707	CE03306250	CAP, ELEC. 33uF 25V
C708, 709	CE01007504	CAP, ELEC. 1uF 50V
C710	CC31009465	CAP, CERAMIC 0.01uF 50V
C711	CC31010431	CAP, CERAMIC 0.001uF 50V
C712	CC31009465	CAP, CERAMIC 0.01uF 50V
C713	CE04706168	CAP, ELEC. 47uF 16V
Q701-704	TR30000327	TRANSISTOR 2SC536G-NP
Q705, 706	TR10000126	TRANSISTOR 2SA608KF
D701-728	DD80000021	DIODE IN4148
IC701, 702	IC00002727	IC TC4532BP
IC703	IC00002340	IC TC4081BP
IC704	IC00001528	IC TC4013BP
IC705	IC00002065	IC TC74HC148P
IC706	IC00002363	IC TC4011BP
IC707	IC00002740	IC uPD4511BAC
IC708	IC00002739	IC LB1407
IC709	IC00000573	IC TD6301AP
X-1189A01T PCB ASSEMBLY		
IC001	IC00002030	REMOTE RECEIVER SBX1610-02
X-1189102T PCB ASSEMBLY		
S001	SH11000458	1 KEY PUSH SW SUN 4TR-2911
X-1189A03T PCB ASSEMBLY		
D001	DD40001257	LED LN16WP
E-1190A00T PCB ASSEMBLY		
R101, 102	RM84751612	R, METAL MK24K75FECZ.
R103	RM82743612	R, METAL MK227K4FECZ.
R105	RM82743612	R, METAL MK227K4FECZ.
R106, 107	RM81003610	R, METAL MK2100KFECZ.
R108	RM84752616	R, METAL MK247K5FECZ.
R109	RM84759611	R, METAL MK247R5FECZ.
R110	RM81500616	R, METAL MK2150RFECZ.
R111, 112	RM82742619	R, METAL MK227K4FECZ.
R113, 114	RM81003610	R, METAL MK2100KFECZ.
R115	RM84759611	R, METAL MK247R5FECZ.
R116	RM82211614	R, METAL MK22K21FECZ.
R117	RM81000619	R, METAL MK2100RFECZ.
R118	RM82211614	R, METAL MK22K21FECZ.
R119	RM81002616	R, METAL MK2010KFECZ.
R120	RM84752616	R, METAL MK247K5FECZ.
R121	RM81002616	R, METAL MK2010KFECZ.
R122	RM84752616	R, METAL MK247K5FECZ.
R123	RM81002616	R, METAL MK2010KFECZ.
R124	RM84750619	R, METAL MK2475RFECZ.
R125	RM81003610	R, METAL MK2100KFECZ.
R126	RM82211614	R, METAL MK22K21FECZ.
R127	RM84759611	R, METAL MK247R5FECZ.
R128, 129	RM81002626	R, METAL MK2010KFECZ.
R130	RM84759611	R, METAL MK247R5FECZ.
R131	RM82742619	R, METAL MK227K4FECZ.
R132	RM81003610	R, METAL MK2100KFECZ.
R133	RM82742619	R, METAL MK227K4FECZ.
R134	RM84750619	R, METAL MK2475RFECZ.
C101	CC33312438	CAP, CERAMIC 33P 50V
C102	CC34712436	CAP, CERAMIC 47P 50V
C103	CC31009465	CAP, CERAMIC 0.01uF 50V

Parts List

SYMBOL	PARTS NO.	DESCRIPTION
C104	CC15013410	CAP,CERAMIC 5P CH 50V
C105	CC31009465	CAP,CERAMIC 0.01uF 50V
C106	CC31010431	CAP,CERAMIC 0.001uF 50V
C107	CC31009465	CAP,CERAMIC 0.01uF 50V
C108	CC13013417	CAP,CERAMIC 3P CH 50V
C109	CC34712436	CAP,CERAMIC 47P 50V
C110	CC31009465	CAP,CERAMIC 0.01uF 50V
C111	CC31010431	CAP,CERAMIC 0.001uF 50V
C112	CC13013417	CAP,CERAMIC 3P CH 50V
C113	CC15013410	CAP,CERAMIC 5P CH 50V
C114	CC13013417	CAP,CERAMIC 3P CH 50V
C115	CE01007504	CAP,ELEC. 1uF 50V
C116	CC31011435	CAP,CERAMIC 100P 50V
C117-119	CC31009465	CAP,CERAMIC 0.01uF 50V
C120	CE04705164	CAP,ELEC. 470uF 16V
C121	CC15013410	CAP,CERAMIC 5P CH 50V
C122	CC17013412	CAP,CERAMIC 7P CH 50V
C123	CC33312438	CAP,CERAMIC 33P 50V
C124	CC15013410	CAP,CERAMIC 5P CH 50V
C125,126	CC31009465	CAP,CERAMIC 0.01uF 50V
C127,128	CC15013410	CAP,CERAMIC 5P CH 50V
C129	CC31009465	CAP,CERAMIC 0.01uF 50V
C130,131	CC15013410	CAP,CERAMIC 5P CH 50V
C132	CC17013412	CAP,CERAMIC 7P CH 50V
CT101-106	CF00000184	FILM TRIMMER CAP. VCT51A
D101	DD10000317	DIODE 1SS110
D102	DD50000055	DIODE SVC211SPA
D103	DD10000317	DIODE 1SS110
D104	DD50000055	DIODE SVC211SPA
D105-108	DD50000055	DIODE SVC211SPA
Q101,102	TR50000140	TRANSISTOR 3SK107F
Q103	TR300000327	TRANSISTOR 2SC536G-NP
Q104,105	TR10000126	TRANSISTOR 2SA608KF
Q106	TR300000327	TRANSISTOR 2SC536G-NP
Q107	TR50000103	TRANSISTOR 2SK544F
Q108	TR30000133	TRANSISTOR 2SC1674
Q109	TR50000103	TRANSISTOR 2SK544F
L101,102	LC23390009	FM ANT. COIL TRL-339
L103	LC23380004	FM RF COIL TRL-338
L104	LC23370000	FM RF COIL TRL-337
L105	LM00000073	MICRO INDUCTOR TRL-239
L106	LC02330000	FM IF COIL TRL-233T
L107,108	LC23360005	FM OSC COIL TRL-336
R301	RM84759611	R,METAL MK247R5FECZ.
R302	RM83320617	R,METAL MK2332RFECZ.
R303	RM81003610	R,METAL MK2100KFECZ.
R304	RM83320617	R,METAL MK2332RFECZ.
R305-307	RM84752616	R,METAL MK247K5FECZ.
R308	RM81213615	R,METAL MK2121KFECZ.
R309	RM84759611	R,METAL MK247R5FECZ.
R310	RM81003610	R,METAL MK2100KFECZ.
R311	RM83320617	R,METAL MK2332RFECZ.
E312	RM84759611	R,METAL MK247R5FECZ.
R313,314	RM83320617	R,METAL MK2332RFECZ.
R315	RM84759611	R,METAL MK247R5FECZ.
R316	RM82210610	R,METAL MK2221RFECZ.
R317	RM83320617	R,METAL MK2332RFECZ.
R318	RM81001612	R,METAL MK2001KFECZ.
R319.320	RM83320617	R,METAL MK2332RFECZ.
R321	RM84759611	R,METAL MK247R5FECZ.
R322	RM82212618	R,METAL MK222K1FECZ.
R323	RM81003610	R,METAL MK2100KFECZ.
R324	RM82212618	R,METAL MK222K1FECZ.
R325	RM84759611	R,METAL MK247R5FECZ.
R326	RM81002616	R,METAL MK2010KFECZ.
R327	RM81000619	R,METAL MK2100RFECZ.
R328	RM82212618	R,METAL MK222K1FECZ.
R329	RM84751612	R,METAL MK24K75FECZ.
R330	RM81002616	R,METAL MK2010KFECZ.

SYMBOL	PARTS NO.	DESCRIPTION
R331	RM84751612	R,METAL MK24K74FECZ.
R332	RM81002616	R,METAL MK2010KFECZ.
R333	RM82212618	R,METAL MK222K1FECZ.
R334	RM81002616	R,METAL MK2010KFECZ.
R335	RM84752616	R,METAL MK247K5FECZ.
R336	RM83321610	R,METAL MK23K32FECZ.
R337	RM84762616	R,METAL MK247K5FECZ.
R338	RM81003610	R,METAL MK2100KFECZ.
R339	RM81001612	R,METAL MK2001KFECZ.
R340,341	RM82211614	R,METAL MK22K21FECZ.
R342,343	RM81000619	R,METAL MK2100RFECZ.
R344	RM83320617	R,METAL MK2332RFECZ.
R345	RM81002616	R,METAL MK2010KFECZ.
R346	RM84752616	R,METAL MK247K5FECZ.
R347	RM86810619	R,METAL MK2681RFECZ.
R348	RM82212618	R,METAL MK222K1FECZ.
R349	RM81002616	R,METAL MK2010KFECZ.
R350-352	RM84752616	R,METAL MK247K5FECZ.
R353	RM88251610	R,METAL MK28K25FECZ.
R354	RM84759611	R,METAL MK247R5FECZ.
R355	RM82431614	R,METAL MK22K43FECZ.
R356	RM82212618	R,METAL MK222K1FECZ.
C301-303	CC31009465	CAP,CERAMIC 0.01uF 50V
C304-312	CC05009457	CAP,CERAMIC 0.047uF 50V
C313-328	CC31009465	CAP,CERAMIC 0.01uF 50V
C329,330	CE01006251	CAP,ELEC. 10uF 25V
C331	CC31009465	CAP,CERAMIC 0.01uF 50V
C332-334	CC05009457	CAP,CERAMIC 0.047uF 50V
C335	CE02206508	CAP,ELEC. 22uF 50V
C336	CS33311310	CAP,POLY. 160V 330P
C337,338	CE01007504	CAP,ELEC. 1uF 50V
C339-343	CC05009457	CAP,CERAMIC 0.047uF 50V
C344	CE51005679	CAP,ELEC. 25BGF100M
C345	CC05009457	CAP,CERAMIC 0.047uF 50V
C346	CE51005679	CAP,ELEC. 25BGF100M
C347	CE01005258	CAP,ELEC. 100uF 25V
X301,302	LF00000099	CERAMIC FILTER SFE10.7MS3GY-A
X303	LF00000415	CERAMIC FILTER SFE10.7MXK-A
X304	LF00000439	CERAMIC FILTER SFE10.7M5-A
X305	LF00000427	CERAMIC FILTER SFE10.7MHY-A
X306	LF00000415	CERAMIC FILTER SFE10.7MXK-A
D301-309	DD80000021	DIODE IN4148
Q301,302	TR50000103	TRANSISTOR 2SK544F
Q303-307	TR300000327	TRANSISTOR 2SC536G-NP
Q308,309	TR10000126	TRANSISTOR 2SA608K
VR301	RV40000095	R,SEMI-FIXED VM6CKPV-1S-B 47KB
VR302	RV40000125	R,SEMI-FIXED VM6CKPV-1S-B 10KB
IC301	IC00001103	IC LA1235
IC302	IC00001516	IC TA7302P
IC303	IC00001656	IC MPC1163H
IC304	IC00001103	IC LA1235
L301	LM00000073	MICRO FILTER TRL-239
L303	LC31090007	IF COIL RLV-109T
R401	RM81000619	R,METAL MK2100RFECZ.
R402	RM82211614	R,METAL MK22K21FECZ.
R403	RM84751612	R,METAL MK24K75FECZ.
R404	RM86812616	R,METAL MK268K1FECZ.
R405	RM83322614	R,METAL MK233K2FECZ.
R406	RM81003610	R,METAL MK2100KFECZ.
R407	RM88250617	R,METAL MK2825RFECZ.
R408	RM81001612	R,METAL MK2001KFECZ.
R409	RM84759611	R,METAL MK247R5FECZ.
R411-413	RM81002616	R,METAL MK2010KFECZ.
R414	RM85621610	R,METAL MK25K62FECZ.
R416	RM82211614	R,METAL MK22K21FECZ.
R417	RM84752616	R,METAL MK247K5FECZ.
R418	RM84759611	R,METAL MK247R5FECZ.

Parts List

SYMBOL	PARTS NO.	DESCRIPTION
R419	RM83322614	R, METAL MK233K2FECZ.
R420	RM81002616	R, METAL MK2010KFECZ.
R421, 422	RM84751612	R, METAL MK24K75FECZ.
R423, 424	RM81003610	R, METAL MK2100KFECZ.
R425	RM84752616	R, METAL MK247K5FECZ.
R426	RM83323618	R, METAL MK2332KFECZ.
R427	RM82213611	R, METAL MK2221KFECZ.
E428	RM81003610	R, METAL MK2100KFECZ.
R429, 430	RM81001612	R, METAL MK2001KFECZ.
R431	RM82212618	R, METAL MK222K1FECZ.
R432	RM81002616	R, METAL MK2010KFECZ.
R433	RM82212618	R, METAL MK222K1FECZ.
R434	RM83321610	R, METAL MK23K32FECZ.
R435	RM84752616	R, METAL MK247K5FECZ.
R436, 437	RM82212618	R, METAL MK222K1FECZ.
R438	RM82743612	R, METAL MK2274KFECZ.
R439	RM83322614	R, METAL MK233K2FECZ.
R440	RM84751612	R, METAL MK24K75FECZ.
R441, 442	RM85621610	R, METAL MK25K62FECZ.
R443, 444	RM84751612	R, METAL MK24K75FECZ.
R447	RM84751612	R, METAL MK24K75FECZ.
R448	RM84751612	R, METAL MK24K75FECZ.
R449	RM88251610	R, METAL MK28K25FECZ.
R450	RM88251610	R, METAL MK28K25FECZ.
R451, 452	RM82211614	R, METAL MK22K21FECZ.
R453, 454	RM86819611	R, METAL MK268R1FECZ.
R455	RM86810619	R, METAL MK2681RFECZ.
R456, 457	RM84751612	R, METAL MK24K75FECZ.
R458, 459	RM83321610	R, METAL MK23K32FECZ.
R460, 461	RM84751612	R, METAL MK24K75FECZ.
R462	RM82212618	R, METAL MK222K1FECZ.
R463, 464	RM61802056	R, METAL VSH183
R465	RM81004613	R, METAL MK2001MFECZ.
R466	RM81000619	R, METAL MK2100RFECZ.
R467, 468	RM67502058	R, METAL VSH753
R469-472	RM64702050	R, METAL VSH473
R473	RM82213611	R, METAL MK2221KFECZ.
R474	RM81004613	R, METAL MK2001MFECZ.
R475	RM81002616	R, METAL MK2010KFECZ.
R476	RM84752616	R, METAL MK247K5FECZ.
R479, 480	RM65600053	R, METAL VSH561
R481, 482	RM61001059	R, METAL VSH102
R483, 484	RM64702050	R, METAL VSH473
R485, 486	RM61000055	R, METAL VSH101
R488, 489	RM81002616	R, METAL MK2010KFECZ.
R490	RM84752616	R, METAL MK247K5FECZ.
R491	RM84759611	R, METAL MK247R5FECZ.
C401	CE51006477	CAP, ELEC. 50BGF10M
C402	CE54705640	CAP, ELEC. 25BGF470M
C403	CE51006477	CAP, ELEC. 50BGF10M
C404	CE61005743	CAP, ELEC. 16BGF100M
C406	CE51005679	CAP, ELEC. 25BGF100M
C407	CM01009427	CAP, MYLAR 103J 50V
C408	CE54707478	CAP, ELEC. 50BGF4R7M
L401	LC23060009	MPX FILTER TRL306
L402	LC23730003	COIL TRL373
L403	LM00000360	MICRO INDUCTOR RLV312
L404	LC23730003	COIL TRL373
R501	RM81000619	R, METAL MK2100RFECZ.
R502	RM81001612	R, METAL MK2001KFECZ.
R503-505	RM84752616	R, METAL MK247K5FECZ.
R506	RM81002616	R, METAL MK2010KFECZ.
R507	RM84752616	R, METAL MK247K5FECZ.
R508-511	RM82212618	R, METAL MK222K1FECZ.
R512	RM84752616	R, METAL MK247K5FECZ.
R513	RN31003080	THICK FILM RS NETWORK A8104J
R521-530	RM82212618	R, METAL MK222K1FECZ.
R531, 532	RM81003610	R, METAL MK2100KFECZ.
R536	RM81003610	R, METAL MK2100KFECZ.

SYMBOL	PARTS NO.	DESCRIPTION
R538	RM84752616	R, METAL MK247K5FECZ.
R539, 540	RM81002616	R, METAL MK2010KFECZ.
R541	RM83322614	R, METAL MK233K2FECZ.
R542-545	RM81002616	R, METAL MK2010KFECZ.
R546	RM82211614	R, METAL MK22K21FECZ.
R547	RM88251610	R, METAL MK28K25FECZ.
R548, 549	RM81000619	R, METAL MK2100RFECZ.
R550	RM88251610	R, METAL MK28K25FECZ.
R551, 552	RM82740611	R, METAL MK2274RFECZ.
R553, 554	RM86812616	R, METAL MK268K1FECZ.
C501	CC31009465	CAP, CERAMIC 0.01uF 50V
C502	CE01005167	CAP, ELEC. 10uF 16V
C503	CC31009465	CAP, CERAMIC 0.01uF 50V
C504	CE01338508	CAP, ELEC. 0.33uF 50V
C505, 506	CC32211432	CAP, CERAMIC 220P 50V
C510, 511	CC01512434	CAP, CERAMIC 15P 50V
C512	CE04705103	CAP, ELEC. 470uF 10V
C513	CC31009465	CAP, CERAMIC 0.01uF 50V
C514	CE52208951	CAP, ELEC. FYD0H224Z
C515	CE01005106	CAP, ELEC. 100uF 10V
C516-519	CC31009465	CAP, CERAMIC 0.01uF 50V
C520	CE51005540	CAP, ELEC. 35BGF100M
C521	CM04709426	CAP, MYLAR 473J 50V
C522	CE01338508	CAP, ELEC. 0.33uF 50V
C523, 524	CE01007504	CAP, ELEC. 1uF 50V
Q501-516	TR30000327	TRANSISTOR 2SC536G-NP
Q517	TR50000127	TRANSISTOR 3SK246-Y
Q518	TR30000509	TRANSISTOR 2SC1570
IC501	IC000001759	IC LC6522C-3433
IC503	IC000001346	IC TC9157AP
IC504	IC000000482	IC TD6104P
D501-545	DD80000021	DIODE IN4148
X501	LF000000294	CERAMIC FILTER CSB800J
X502	DD600000040	CRYSTAL OSC. HC49U7.2MHZ
R601, 602	RM81502613	R, METAL MK2015KFECZ.
R603	RM83321610	R, METAL MK23K32FECZ.
R604	RM81002616	R, METAL MK2010KFECZ.
R607-609	RM81002616	R, METAL MK2010KFECZ.
R610	RM84752616	R, METAL MK247K5FECZ.
R611	RM88250617	R, METAL MK2825RFECZ.
R612	RM86812616	R, METAL MK268K1FECZ.
R613, 614	RM81002616	R, METAL MK2010KFECZ.
R615	RM84752616	R, METAL MK247K5FECZ.
R616	RM82741615	R, METAL MK22K74FECZ.
R617	RM82211614	R, METAL MK222K1FECZ.
R618	RM83323618	R, METAL MK2332KFECZ.
R619	RM84752616	R, METAL MK247K5FECZ.
R620	RM81002616	R, METAL MK2010KFECZ.
R621	RM81003610	R, METAL MK2100KFECZ.
R622	RM81002616	R, METAL MK2010KFECZ.
R623	RM84752616	R, METAL MK247K5FECZ.
R624	RM81000619	R, METAL MK2100RFECZ.
R625-627	RM84752616	R, METAL MK247K5FECZ.
R628, 629	RM81002616	R, METAL MK2010KFECZ.
R630	RM84753610	R, METAL MK2475KFECZ.
R631	RM85620616	R, METAL MK2562RFECZ.
R632	RM83322614	R, METAL MK233K2FECZ.
R634	RM85620616	R, METAL MK2562RFECZ.
C601	CE51005540	CAP, ELEC. 35BGF100M
C602	CE64706677	CAP, ELEC. 25BGF47M
C603	CE02205449	CAP, ELEC. 220uF 63V
C604	CE72205645	CAP, ELEC. 25V 220uF HFS
C605	CE74705256	CAP, ELEC. 25V 470uF HFS
C606	CE72205645	CAP, ELEC. 25V 220uF HFS
C607	CE74705256	CAP, ELEC. 25V 470uF HFS
C608	CE04706508	CAP, ELEC. 47uF 50V
C609	CE04706259	CAP, ELEC. 47uF 25V
C610, 611	CE51005679	CAP, ELEC. 25BGF100M
C612, 613	CE51005679	CAP, ELEC. 100uF 25V
C614	CE01005167	CAP, ELEC. 100uF 16V

Parts List

SYMBOL	PARTS NO.	DESCRIPTION
C409	CY24708425	CAP, LAYER 50MSA474J
C410	CY21008428	CAP, LAYER 50MSA104J
C411, 412	CM01009427	CAP, MYLAR 103J 50V
C413	CE01007504	CAP, ELEC. 1uF 50V
C414, 415	CE64706677	CAP, ELEC. 25BGF47M
C416	CS41000429	CAP, STYROL 1000P 50V
C417	CM01009427	CAP, MYLAR 103J 50V
C419	CM04709426	CAP, MYLAR 473J 50V
C420	CS31510302	CAP, POLY. 1500P 160V
C423, 424	CE51005679	CAP, ELEC. 25BGF100M
C427, 428	CE51005679	CAP, ELEC. 25BGF100M
C430	CS31510302	CAP, POLY. 1500P 160V
C431, 432	CS33310304	CAP, POLY. 3300P 160V
C433	CM01010429	CAP, MYLAR 102J 50V
C434	CM01009427	CAP, MYLAR 103J 50V
C435, 436	CE51006477	CAP, ELEC. 50BGF10M
C436-440	CS31011310	CAP, POLY. 100P 160V
C441, 442	CE72205645	CAP, ELEC. 220uF 25V HFS
C443, 444	CP61008321	CAP, M.P 104K 100V
C445, 446	CE74705256	CAP, ELEC. 220uF 25V HFS
C447, 448	CP61008321	CAP, M.P 104K 100V
C449, 450	CE64706677	CAP, ELEC. 25BGF47M
D401	DD20000168	DIODE RD5.6E
D402, 403	DD80000021	DIODE IN4148
D404	DD20000168	DIODE RD5.6E
D405, 406	DD80000021	DIODE IN4148
D407	DD20000168	DIODE RD5.6E
D408	DD80000021	DIODE IN4148
Q401, 402	TR30000431	TRANSISTOR 2SC1570
Q403, 404	TR30000327	TRANSISTOR 2SC536G-NP
Q405	TR10000254	TRANSISTOR 2SA1345
Q406	TR30000327	TRANSISTOR 2SC536G-NP
Q407	TR30000492	TRANSISTOR 2SC3399
Q408	TR50000127	TRANSISTOR 2SK246-Y
Q409	TR30000431	TRANSISTOR 2SC1570
Q410, 411	TR10000102	TRANSISTOR 2SA929
Q412	TR30000431	TRANSISTOR 2SC1570
Q413	TR10000369	TRANSISTOR 2SA1238
Q414	TR30000649	TRANSISTOR 2SC3065
Q415	TR10000369	TRANSISTOR 2SA1238
Q416	TR30000649	TRANSISTOR 2SC3065
Q417	TR50000176	TRANSISTOR 2SA366
Q418	TR10000126	TRANSISTOR 2SA608KF
Q419, 420	TR30000327	TRANSISTOR 2SC536G-NP
Q421	TR10000126	TRANSISTOR 2SA608KF
IC401	IC00002752	IC LA3433
IC402-404	IC00001693	IC NE5532AN
IC405, 406	IC00002478	IC AD847JN
RY401	LY00000253	RELAY RY-12W Δ
X401	LF00000403	CERAMIC FILTER CSB456F15
VR401	RV40000101	R, SEMI-FIXED VM6CKPV-1S-B 20KB
VR402, 403	RV40000113	R, SEMI-FIXED VM6CKPV-1S-B 3.3KB
VR404, 405	RV40000095	R, SEMI-FIXED VM6CKPV-1S-B 47KB
C615	CE04706168	CAP, ELEC. 47uF 16V
C616	CE04707252	CAP, ELEC. 4.7uF 25V
D601	DD80000021	DIODE IN4148
D602	DD20000193	DIODE RD15E
D603	DD10000391	DIODE E-562
D604, 605	DD20000193	DIODE RV15
D606	DD10000391	DIODE E562
D607, 608	DD80000021	DIODE IN4148
D609	DD20000016	DIODE RD12E
D610-613	DD80000021	DIODE IN4148
D614	DD10000068	DIODE IN4003
Q601, 602	TR30000509	TRANSISTOR 2SC1570
Q603	TR30000327	TRANSISTOR 2SC536G-NP
Q604	TR10000047	TRANSISTOR W/MICA 2SB631KE

SYMBOL	PARTS NO.	DESCRIPTION
Q605	TR10000126	TRANSISTOR 2SA608KF
Q606	TR40000069	TRANSISTOR W/MICA 2SD600K
Q607, 608	TR30000492	TRANSISTOR 2SC3399
Q609	TR10000126	TRANSISTOR 2SA608KF
Q610, 611	TR30000327	TRANSISTOR 2SC536G-NP
Q612	TR30000492	TRANSISTOR 2SC3399
Q613	TR10000126	TRANSISTOR 2SA608KF
Q614	TR10000059	TRANSISTOR 2SB764E/F
Q615, 616	TR30000327	TRANSISTOR 2SC536G-NP
Q617	TR10000059	TRANSISTOR 2SB764E/F
Q618	TR10000126	TRANSISTOR 2SA608K
Q619	TR30000327	TRANSISTOR 2SC536G-NP
Q620	TR10000254	TRANSISTOR 2SA1345
Q621	TR30000492	TRANSISTOR 2SC3399
Q622	TR30000327	TRANSISTOR 2SC536G-NP
Q623	TR30000492	TRANSISTOR 2SC3399
Q624	TR30000327	TRANSISTOR 2SC536G-NP
IC601	IC00000615	IC NJM78M05
IC602	IC00000974	IC NJM78M12
IC603	IC00001267	IC NJM78M15
IC604	IC00000974	IC NJM79M12
IC605	IC00000615	IC NJM78M05
RY601	LY00000253	RELAY RY12W Δ
OTHERS		
	AB00000675	BOTTOM BOARD PT3-05C00T
	AF30000188	FRONT CHASSIS PT2-03B00T
	AM00002037	SUB CHASSIS PT2-04C00T
	AS01000269	RJ SIDE CHASSIS PK3-08D00T
	PT00000345	POWER TRANSFORMER T-1042P02 Δ
	CK00000035	SPARK KILLER DE7150F472M Δ
	BC00000143	CYLINDER BUSH 4TVL-8#2 6Fx12H
	BC00000283	CYLINDER BUSH 4TVL-8#1 6Fx10H
	BC00000751	CYLINDER BUSH 4TVL-8#13 6Fx5H
	BC00000763	CYLINDER BUSH 4TVL-8#14 6Fx7H
	BC00000775	CYLINDER BUSH 4TVL-8#15 6Fx13.5H
	FT00000205	ZNS FOOT PK4-07A00T
	SB00000820	P.V.C SHIELD PLATE C-4463A00T
	SP10006211	P.C.B SUPPORT PK4-28A00T
	SP40000838	SHIELD COVER 4TTR-10A#2
	AR30000209	PRINTED REAR CHASSIS TRP-611
	SA00002223	AC INLET SOCKET 4TR-2786
	VC00000050	VOLTAGE SELECTOR C-4304A02 FS907K
	NP00002073	NAME PLATE 120V N-756
	NP00002097	NAME PLATE 240V N-758
	NP00002085	NAME PLATE 230V N-757
	AA30000424	FRONT PANEL PT2-01A00
	AW00000654	RJ SENSOR WINDOW PT4-12A00T
	AW00000678	PANEL WINDOW PT4-06A00T
	BU00001121	PUSH BUTTON RING PK4-19B00T
	KB20002966	PUSH BUTTON 5F PT4-07A00
	OM10001557	LED TACT MOLD PT3-14A00T
	OM10001569	TACT MOLD PT3-15A00T
	OM10001624	ORNAMENTAL BAR PT4-09A00
	BU00001285	LED BUSH PT4-16A00T
	BU00001327	RUBBER BUSH C-4449A01
	AG00000317	RJ REMOTE CONTROL HANDSET RHT-10AT

Parts List

SYMBOL	PARTS NO.	DESCRIPTION
	AU00001341	TOP COVER PK3-05A00
	KB20002978	PUSH BUTTON PK4-16A00
	OM10001545	FL ORNAMENTAL PLATE PT4-10B00T
	OM70000314	FILTER BOARD C-4462A01T
	OM70000326	FILTER BOARD C-4462A02T
	MN10003001	OWNER'S MANUAL RHT-10
	PL00001208	STYROL PLATE (A) PK4-40A02T
	PL00001210	STYROL PLATE (B) PK4-40A03T
	PL00001221	STYROL PLATE (C) PK4-40A04T
	PL00001233	STYROL PLATE (D) PK4-40A05T
	TN10004293	INSIDE CARTON PT4-20A00
	TN20002858	SHIPPING CARTON PT4-211A00T
	TN30000022	SIDE SHEET PK4-37B00
	CD00000358	AC POWER CORD C-4392A01 -U,C Δ
	CD00000360	AC POWER CORD C-4393A01 -H,E Δ
	CD00000371	AC POWER CORD C-4393A02 -K1 Δ
	CD00000383	AC POWER CORD C-4423A01 -G Δ

Schematic Diagram

Schematic Diagram RHT-10

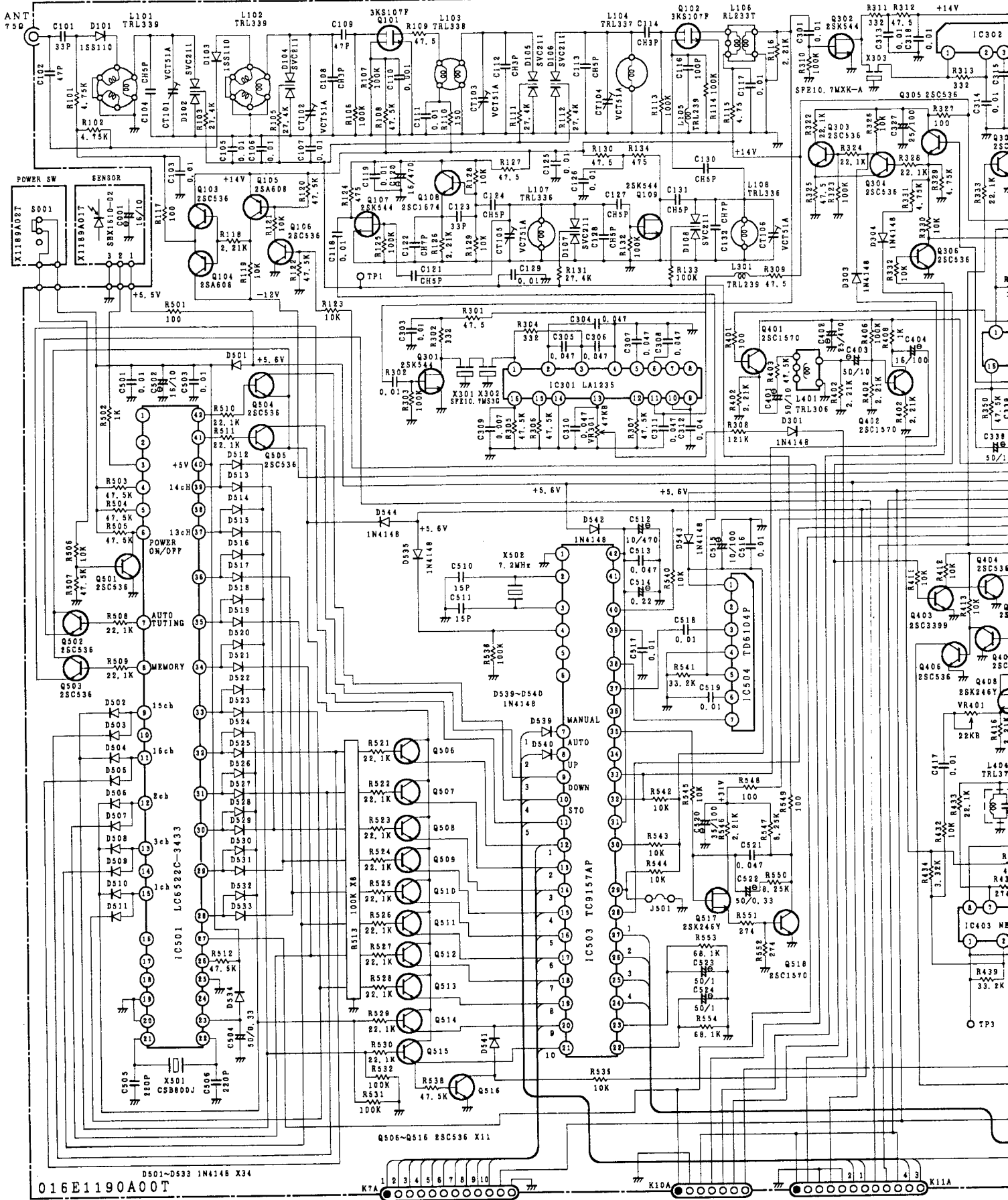

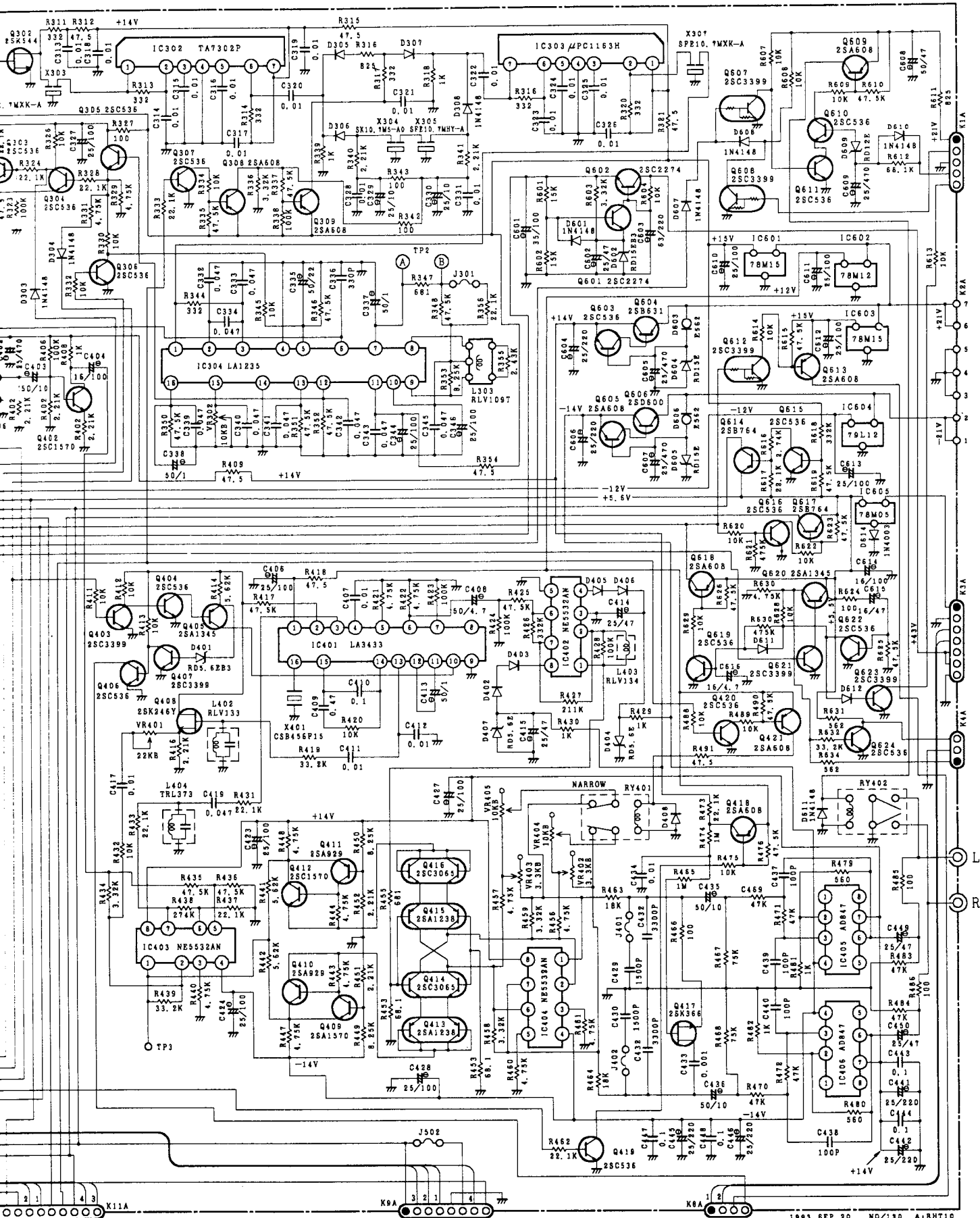

Schematic Diagram

Schematic Diagram RHT-10

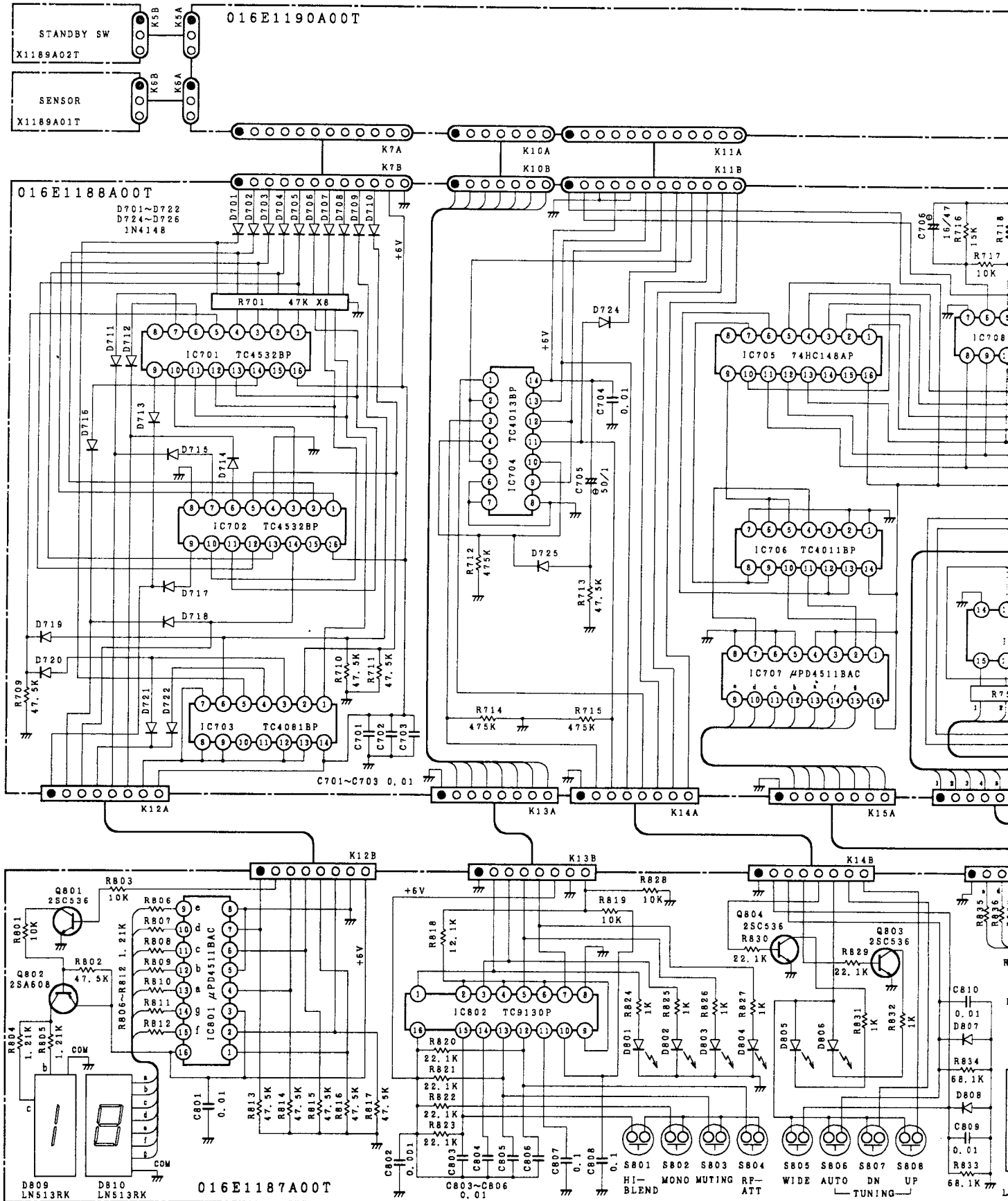

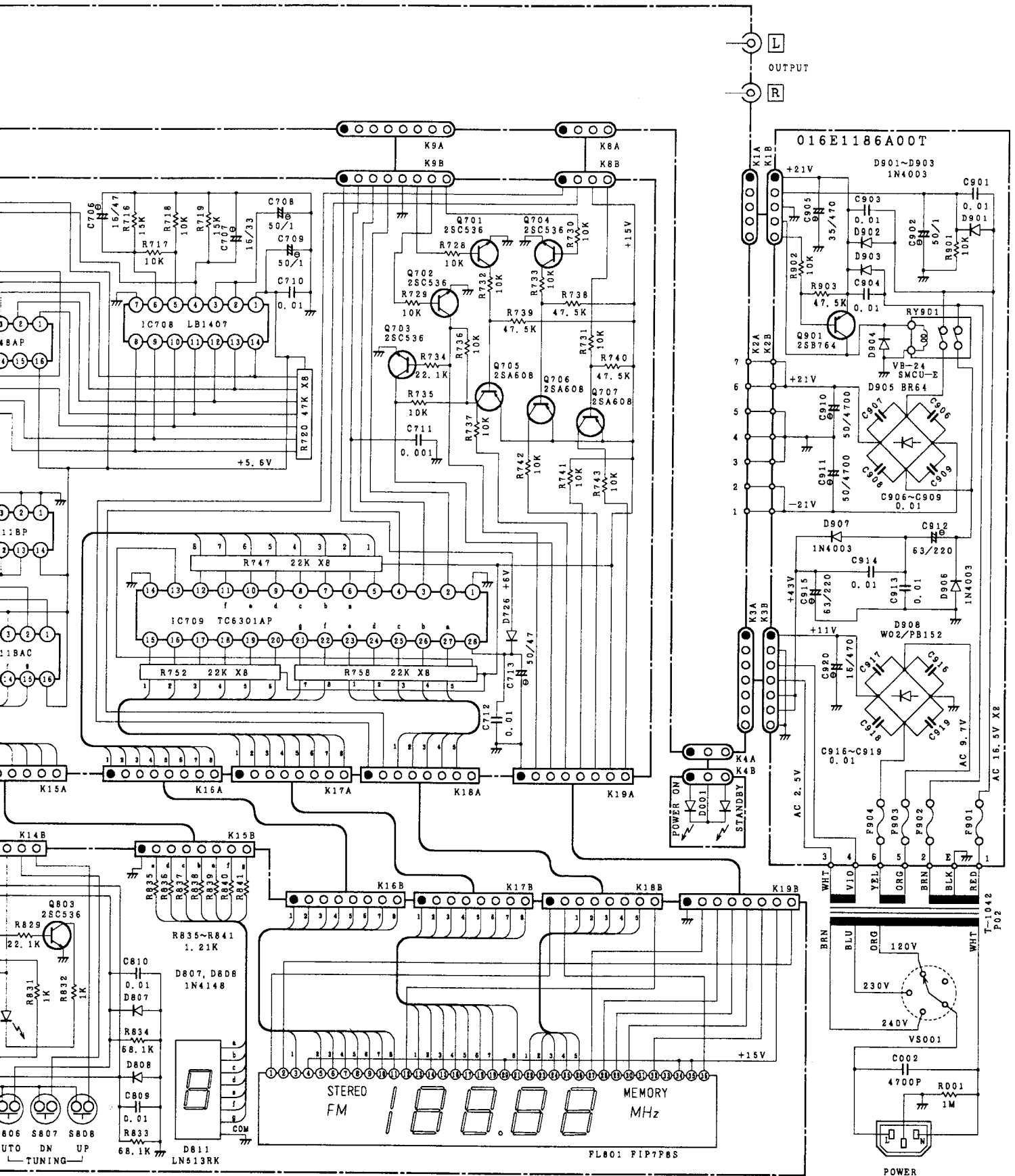

Wiring Diagram

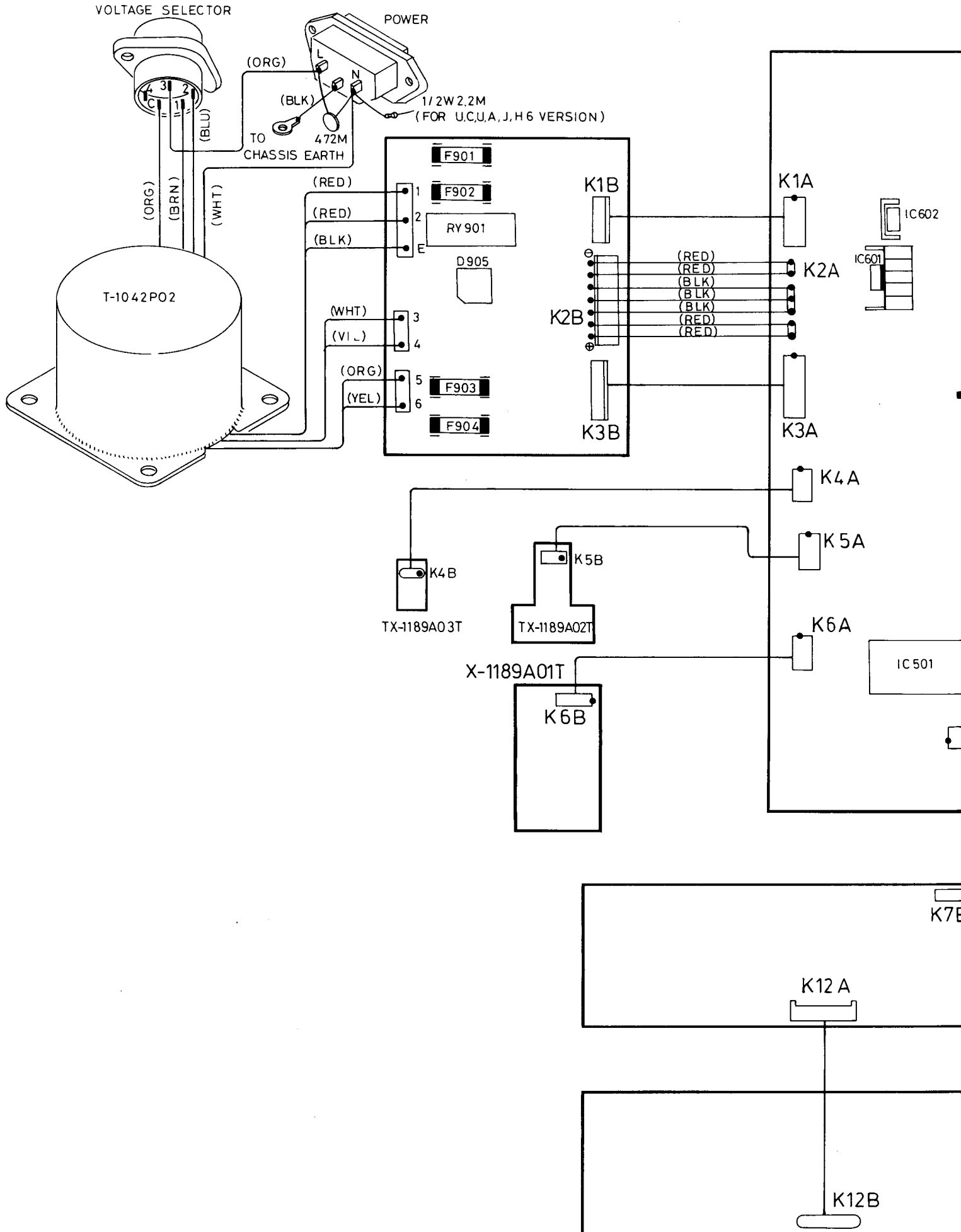

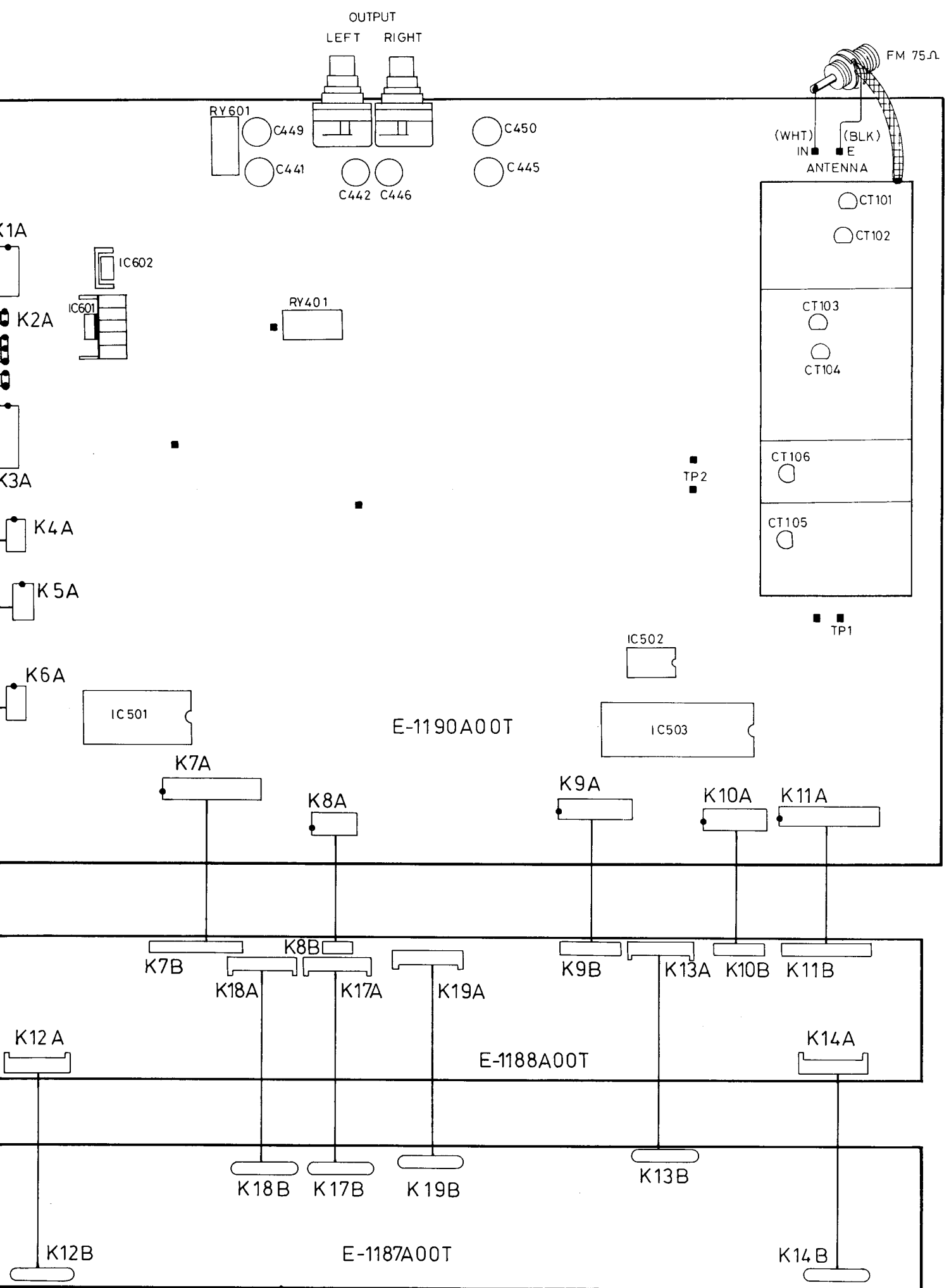

Printed Circuit Boards

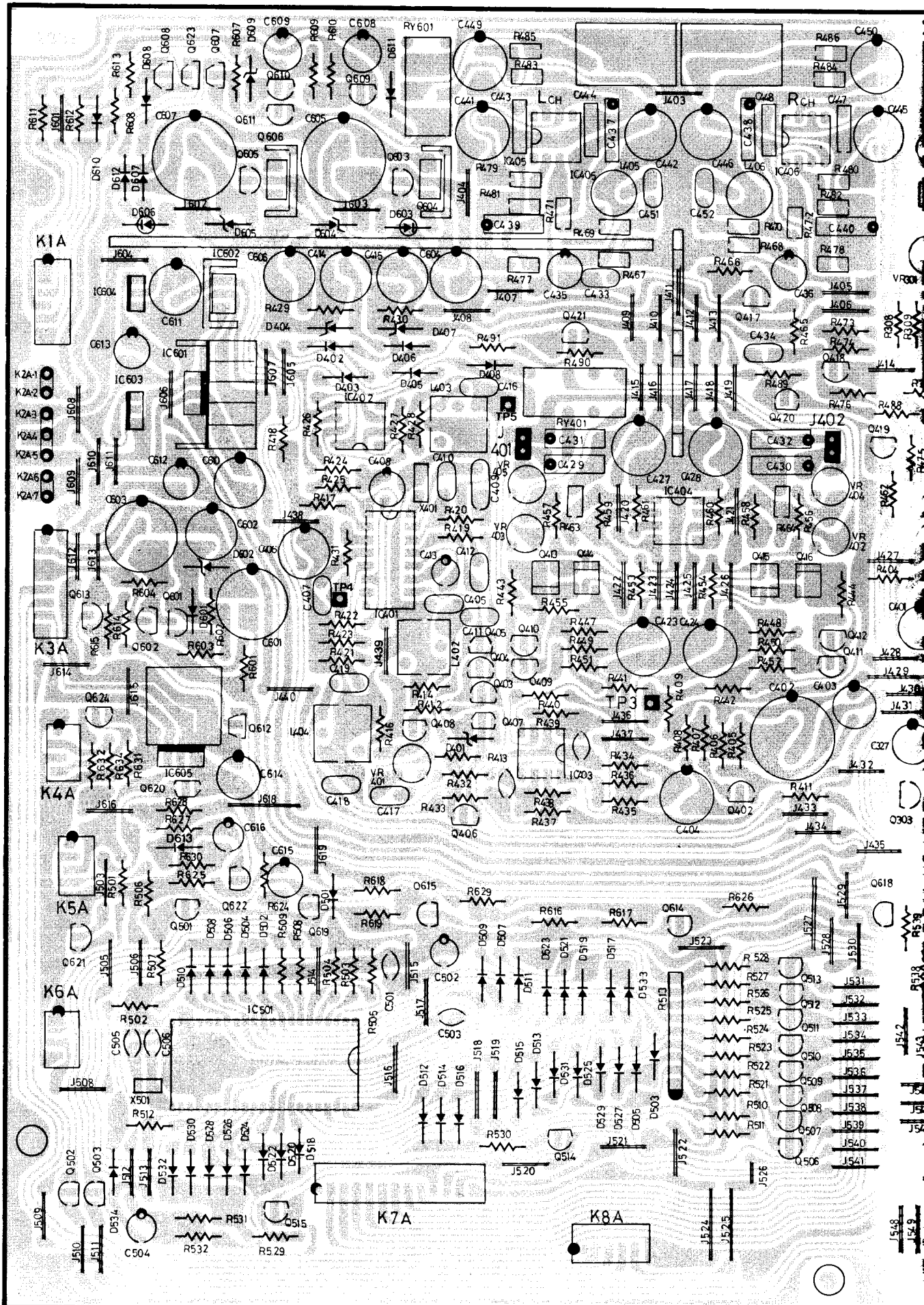

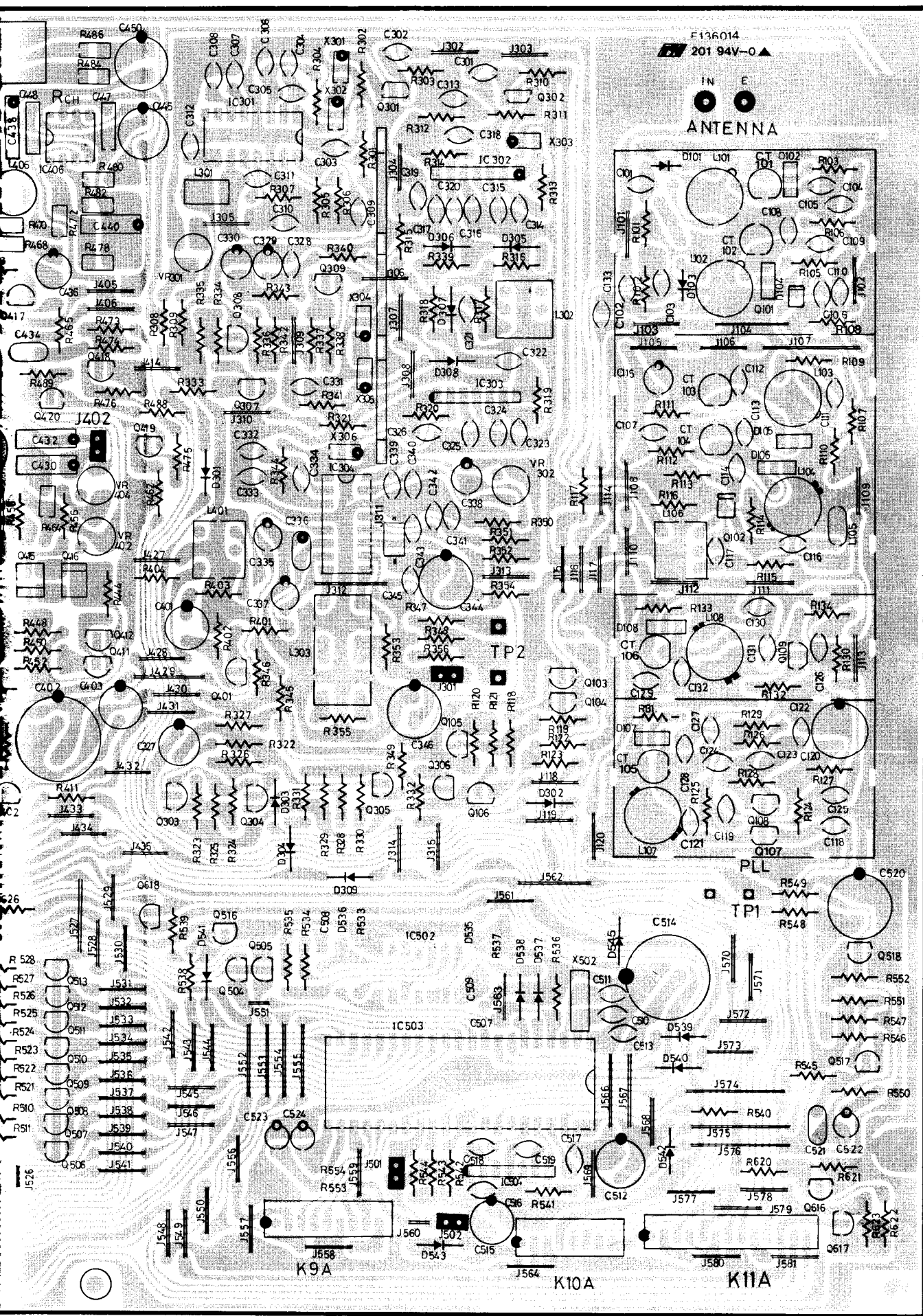

Printed Circuit Boards

