



45 241 A11

# Service Manual



## CONTENTS

- 1 Control buttons and connections
- 2 Technical data , Servicing hints and tools  
Disassembly hints , Exploded view , Mechanical partslist
- 3 Faultfinding procedure , Error codes , Block diagram  
Main panel info
- 4 Display panel info , Wiring diagram
- 5 Partslist
- 6 Modifications

(GB)

Safety regulations require that the set be restored to its original condition and that parts which are identical with those specified be used.

(NL)

Veiligheidsbepalingen vereisen, dat het apparaat in zijn oorspronkelijke toestand wordt teruggebracht en dat onderdelen, identiek aan de gespecificeerde worden toegepast.

(D)

Bei jeder Reparatur sind die geltenden Sicherheitsvorschriften zu beachten. Der Originalzustand des Geräts darf nicht verändert werden für Reparaturen sind Original-Ersatzteile zu verwenden.

(I)

Le norme di sicurezza esigono che l'apparecchio venga rimesso nelle condizioni originali e che siano utilizzati pezzi di ricambio identici a quelli specificati.

(F)

Les normes de sécurité exigent que l'appareil soit remis à l'état d'origine et que soient utilisées les pièces de rechange identiques à celles spécifiées.

(SF) Varo!

Avattaessa ja suojalukitus ohitettaessa olet alltiina näkymättömälle lasersäteilylle. Älä katso säteeseen.

(S) Varning!

Osynlig laserstrålning när denna del är öppnad och spärren är urkopplad. Betrakta ej strålen.

**CLASS 1  
LASER PRODUCT**

3122 110 03420



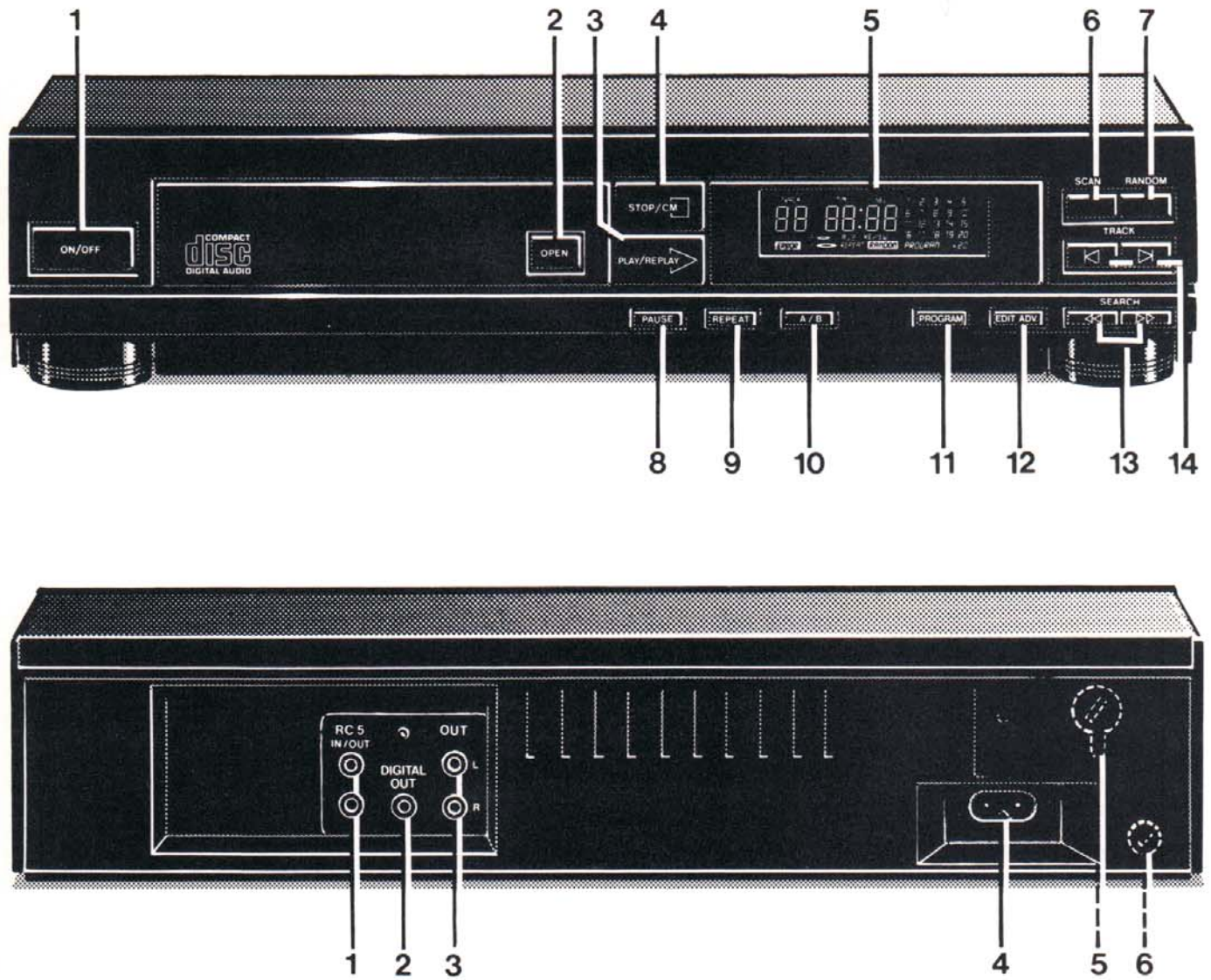

45 242 A11

**CONTROL BUTTONS AND CONNECTIONS :**

front of player :

- 1 On/Off
- 2 Open
- 3 Play/Replay
- 4 Stop/Clear Memory
- 5 Display
- 6 Scan
- 7 Random
- 8 Pause
- 9 Repeat
- 10 Repeat A/B
- 11 Program
- 12 Edit Advanced
- 13 << Search >>
- 14 < Track >

back of player :

- 1 RC5 in/out (remote control)
- 2 Digital Output
- 3 Audio output L/R
- 4 Mains Inlet
- 5 Voltage selector (not for all versions)
- 6 Mains fuseholder (not for all versions)



**TECHNICAL DATA :****General**

- |                                      |   |                          |
|--------------------------------------|---|--------------------------|
| 1. Mains voltage                     | : | 220 , 240 Volt (+/- 10%) |
| 2. Mains frequency                   | : | 50 Hz                    |
| 3. Mains voltage selection           | : | By soldering             |
| 4. Power consumption mains, operated | : | 12W                      |

**External RC-5 connection**

- |               |   |                                |
|---------------|---|--------------------------------|
| Specification | : | V-in Low : from -2,0V to +1,6V |
|               | : | V-in High : from +3V to +7,5V  |
|               | : | R-in : from 47 kOhm to 68 kOhm |

**Line output**

- |  |   |   |
|--|---|---|
| 1. Number of channels  | : | 2   |
| 2. Output voltage  | : | 2 Vrms +/- 2dB  |
| 3. Unbalance left-right  | : | max +/- 0,5dB   |
| 4. Output resistance   | : | 1 kOhm  |
| 5. Amplitude linearity   | : | max. +/- 0,2dB from 20 Hz to 18 kHz<br>typ. +/- 0,02dB from 20 Hz to 18 kHz |
| 6. Phase non-linearity   | : | max. +/- 1,0° from 20 Hz to 18 kHz<br>typ. +/- 0,5° from 20 Hz to 18 kHz    |
| 7. Signal to noise ratio   | : | min. 90dB from 20 Hz to 18 kHz<br>typ. 95dB                                 |
| 8. Dynamic range (-60dB)   | : | min. 80dB from 20 Hz to 18 kHz (max. 0,01 %)<br>typ. 86dB (typ. 0,005 %)    |
| 9. Total harmonic distortion + noise                               | : | min. 66dB from 20 Hz to 18 kHz (max. 0,05 %)<br>typ. 76dB (typ. 0,016 %)    |
| 10. Intermodulation distortion                                     | : | min. 66dB from 20 Hz to 18 kHz (max. 0,05 %)<br>typ. 76dB (typ. 0,016 %)    |
| 11. Outband attenuation  | : | min. 50dB above 24.8 kHz  |
| 12. Channel separation   | : | min. 80dB from 20 Hz to 18 kHz<br>typ. 93dB                                 |
| 13. Muting during random acces                                     | : | min. 90dB from 20 Hz to 18 kHz  |
| 14. Automatic switched de-emphasis<br>whith time constant 15/50 µs | : |   |

**Dimensions and weight**

- |                          |   |                            |
|--------------------------|---|----------------------------|
| 1. Apparatus tray closed | : | WxDxH 360 x 300 x 80/86 mm |
| 2. Apparatus tray open   | : | WxDxH 360 x 445 x 80/86 mm |
| 3. Weight                | : | 3,5 kg                     |

**Laser diode**

- |                                      |   |               |
|--------------------------------------|---|---------------|
| 1. Wavelength                        | : | 780nm +/- 5nm |
| 2. Output power on laserdiode        | : | typ. 3 mW     |
| 3. Output power after objective lens | : | 100 µW        |

**(GB) WARNING**

All ICs and many other semi-conductors are susceptible to electrostatic discharges (ESD). Careless handling during repair can reduce life drastically.

When repairing, make sure that you are connected with the same potential as the mass of the set via a wrist wrap with resistance. Keep components and tools also at this potential.

**(F) ATTENTION**

Tous les IC et beaucoup d'autres semi-conducteurs sont sensibles aux décharges statiques (ESD).

Leur longévité pourrait être considérablement écourtée par le fait qu'aucune précaution n'est prise à leur manipulation.

Lors de réparations, s'assurer de bien être relié au même potentiel que la masse de l'appareil et enfiler le bracelet serti d'une résistance de sécurité.

Veiller à ce que les composants ainsi que les outils que l'on utilise soient également à ce potentiel.

**(D) WARNUNG**

Alle ICs und viele andere Halbleiter sind empfindlich gegen elektrostatische Entladungen (ESD).

Unvorsichtige Behandlung bei der Reparatur kann die Lebensdauer drastisch vermindern. Sorgen sie dafür, dass Sie im Reparaturfall über ein Pulsarmband mit Widerstand mit dem Massepotential des Gerätes verbunden sind. halten Sie Bauteile und Hilfsmittel ebenfalls auf diesem Potential.

**(NL) WAARSCHUWING**

Alle IC's en vele andere halfgeleiders zijn gevoelig voor electrostatische ontladingen (ESD).

Onzorgvuldig behandelen tijdens reparatie kan de levensduur drastisch doen verminderen. Zorg ervoor dat u tijdens reparatie via een polsband met weerstand verbonden bent met hetzelfde potentiaal als de massa van het apparaat.

Houd componenten en hulpmiddelen ook op ditzelfde potentiaal.

**(I) AVVERTIMENTO**

Tutti IC e parecchi semi-conduttori sono sensibili alle scariche statiche (ESD).

La loro longevità potrebbe essere fortemente ridatta in caso di non osservazione della più grande cauzione alla loro manipolazione.

Durante le riparazioni occorre quindi essere collegato allo stesso potenziale che quello della massa dell'apparecchio tramite un braccialeto a resistenza.

Assicurarsi che i componenti e anche gli utensili con quali si lavora siano anche a questo potenziale.

## SERVICING HINTS

In the set chip components have been applied.  
For disassembly and assembly of chip components see the figure below.

The disc should always rest properly on the turntable.  
To achieve this a disc hold-down has been mounted in a bracket of the tray mechanism.  
If the tray mechanism has to be disassembled for servicing, a separate disc hold-down should be used.  
(See drawing "Service disc hold-down")

The set can function normally then.  
Code number of the disc hold-down is 4822 462 50383.

**When the tray mechanism has been disassembled, the tray switch must be activated immediately after pressing the play button in order to ensure normal operation.**

To avoid electric shock during servicing, it is recommended to mount an insulation cover over the mains leads on the servo & decoder panel. See drawing MDA 02548. The cover can be ordered under codenumber 4822 444 60655.

## SERVICE TOOLS

Audio signals disc	4822 397 30184
Disc without errors (test disc 5) + disc with DO errors, black spots and fingerprints (test disc 5A)	4822 397 30096
Disc 65 min 1 kHz without pause	4822 397 30155
Max. diameter disc(58.0 mm)	4822 397 60141
Torx screwdrivers	
Set (straight)	4822 395 50145
Set (square)	4822 395 50132
13th order filter	4822 395 30204
Service cable (4p)	4822 321 21284
Service flexfoil (14p)	4822 322 40066
Service connector (14p)	4822 267 50676
Green LED CQY G11	5322 130 32182
Insulation cover	4822 444 60655

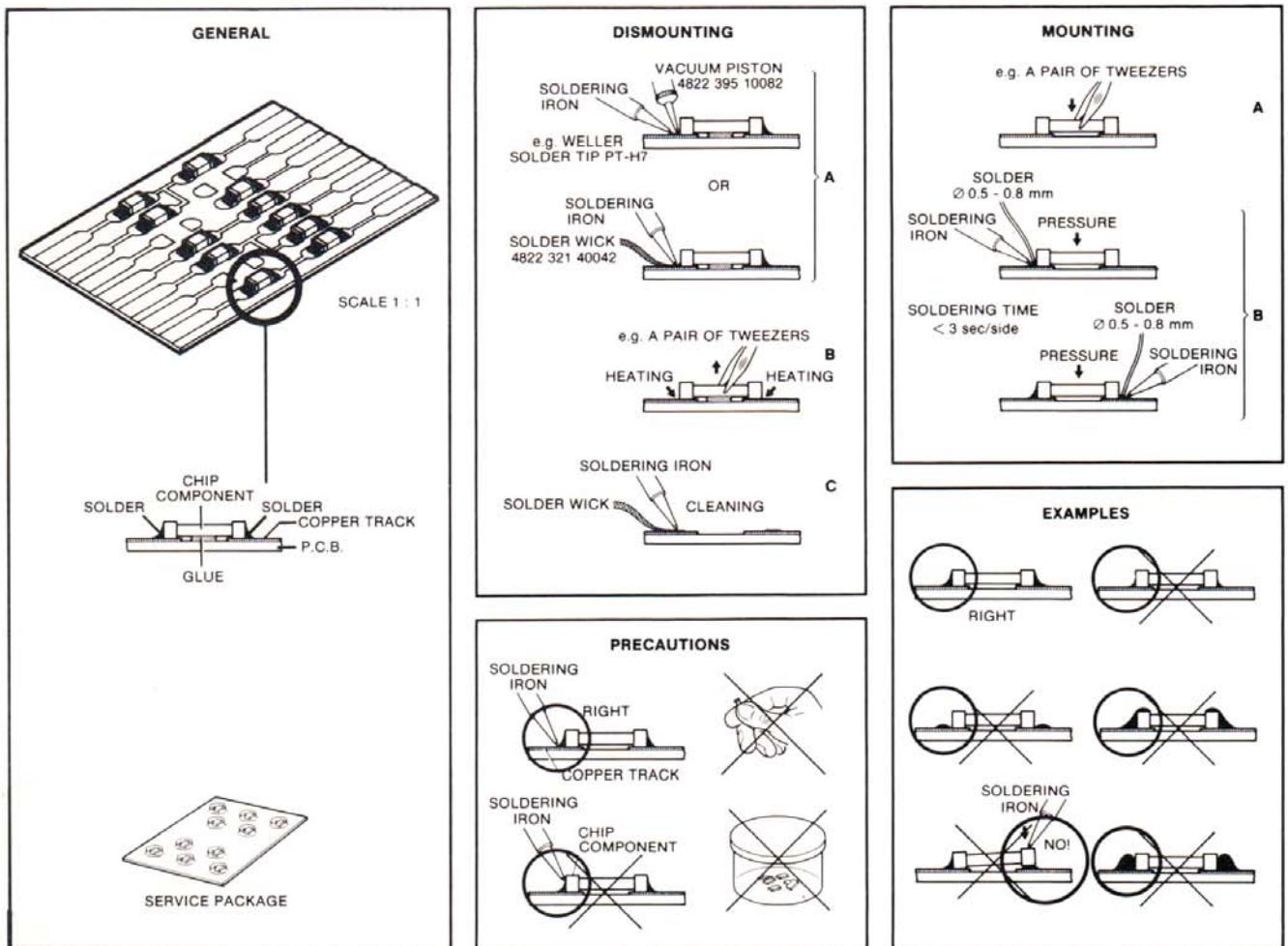



**SERVICE DISC HOLDDOWN**

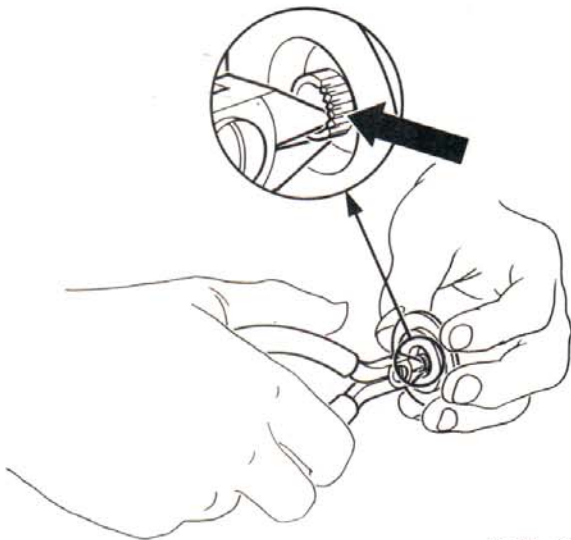

42 565 A12

**Compose a service Disc hold-down in the following way**

- Cut in the most inner ring of a disc hold-down (4822 462 50383) with small and sharp nippers, see fig. above.
- Enlarge the diameter of the innermost ring slightly with the hind part of a pencil or ballpoint, so that it jams onto the turntable with sufficient force.
- If the jamming force decreases after certain time of use, the diameter has to be enlarged with a pencil or ballpoint again.

**SERVICE FOIL FOR CDM**

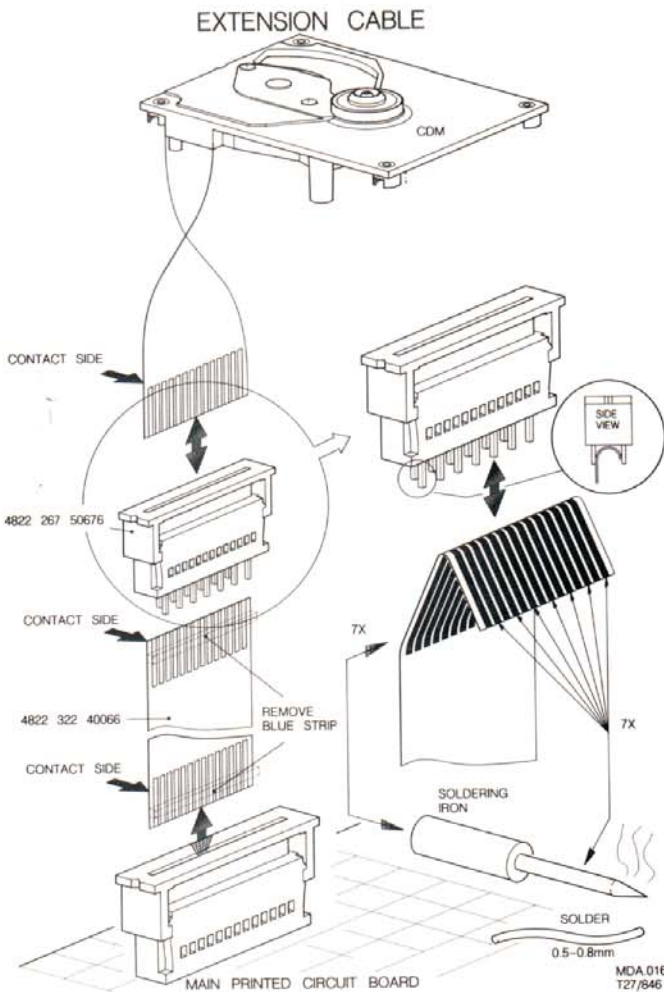

MDA.01671  
T27/846

**CABINET DISASSEMBLY HINTS**

**A Remove 2 front feet**

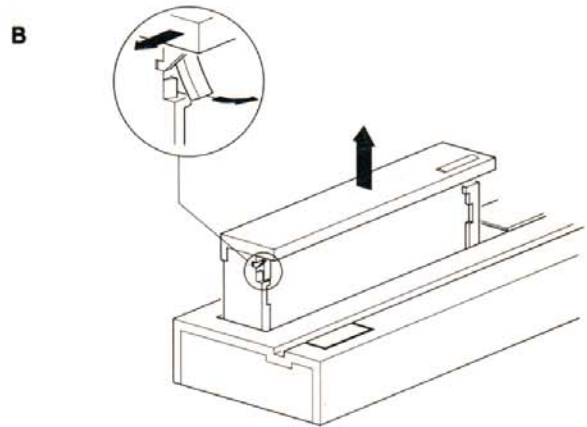

**C**

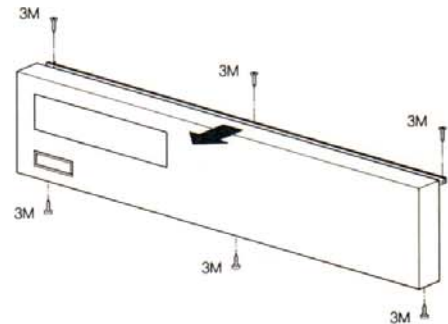

MDA.02137  
916/T19

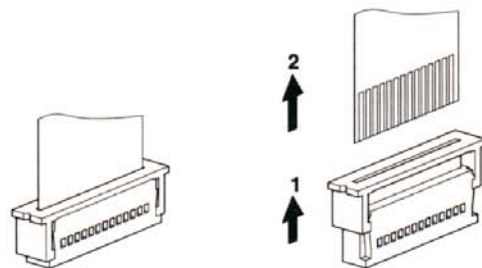

MDA.01408  
T28/822

**DISASSEMBLY OF LOADING AND CDM**

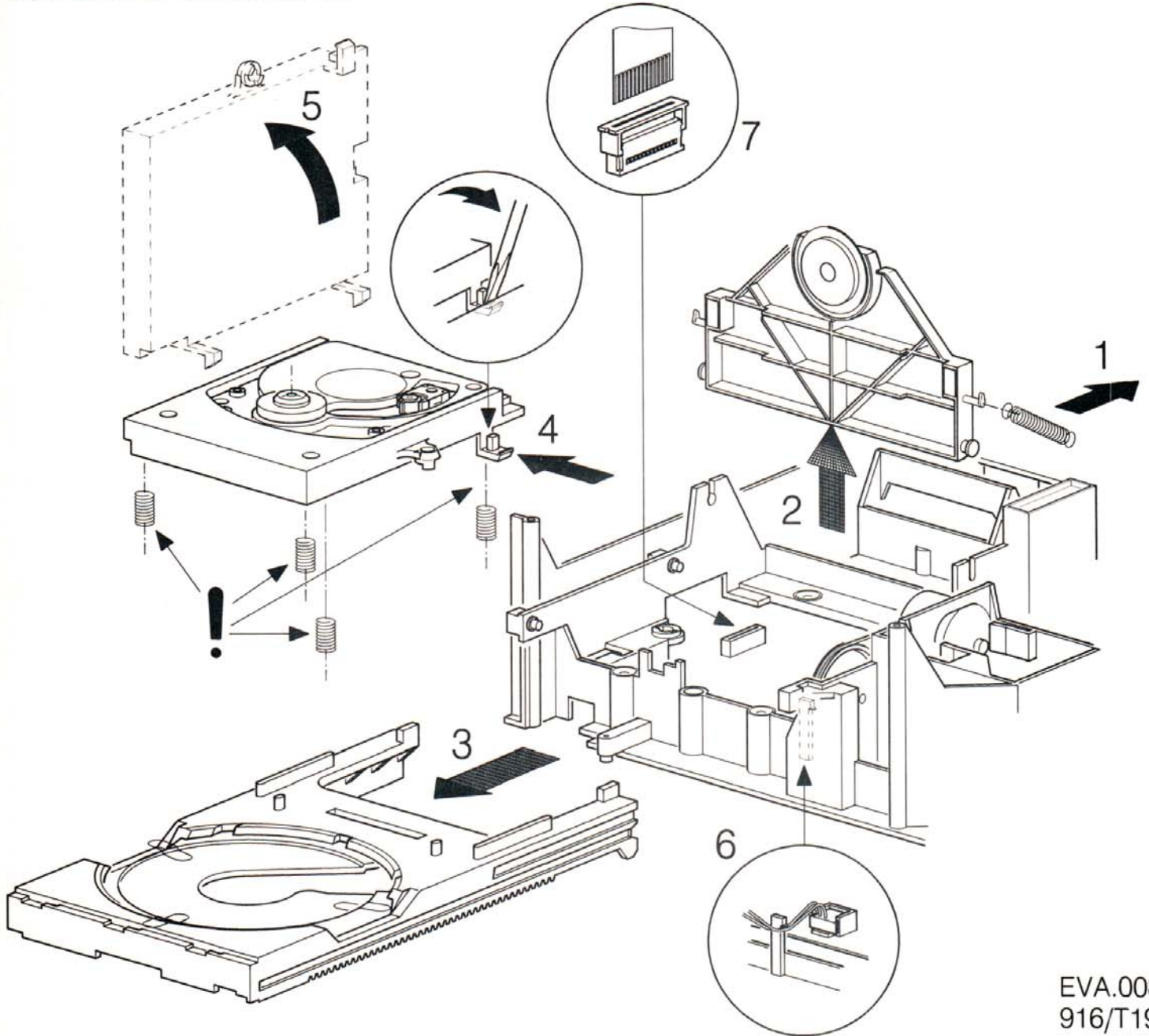

EVA.00846  
916/T19

**PLAY SERVICE POSITION**

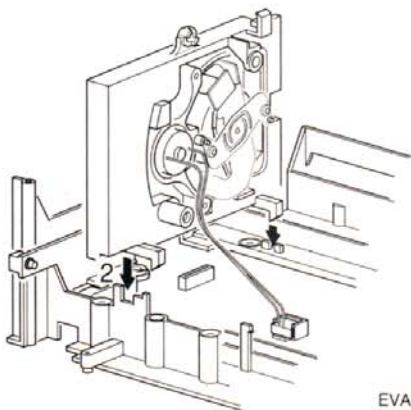

EVA.00848  
916/T19

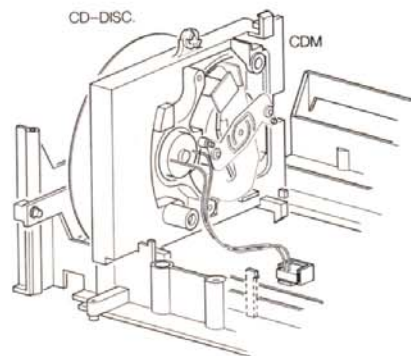

EVA.00849  
916/T19

**FOR ACCESS OF THE MAIN PCB, REMOVE THE  
BOTTOM PLATE**

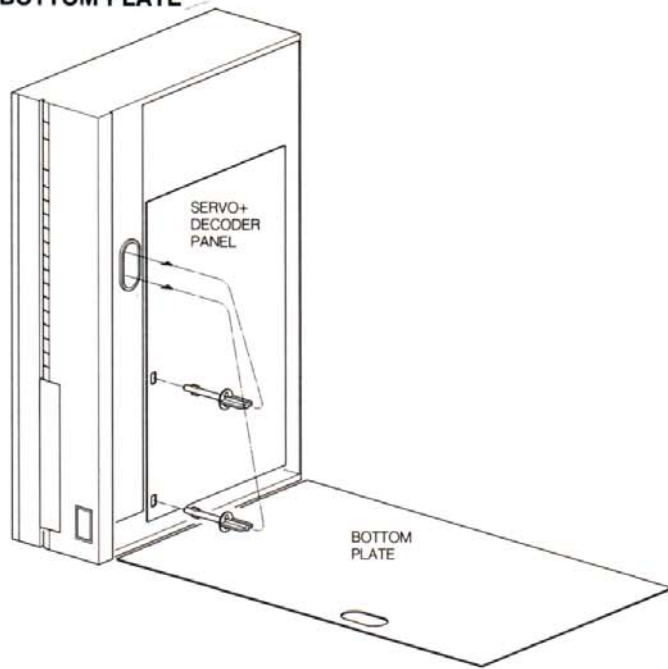

MDA.02138  
916/T19

**INSULATION COVER**

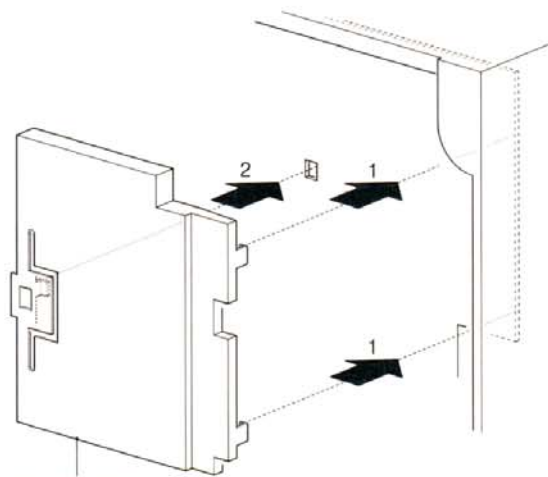

4822 444 60655

TO AVOID ELECTRIC SHOCK DURING SERVICING MOUNT  
INSULATION COVER OVER MAINS LEADS ON MAIN PANEL

MDA.02548  
T02/007

## MECHANICAL PARTSLIST

201	4822 410 60107	
202	4822 459 10806	
203	4822 444 40361	for /00B/05B/10G
203	4822 444 40409	for /40B/45B
206	4822 444 40363	for /00B/05B/10G
206	4822 444 40413	for /40B/45B
208	4822 381 11053	for /00B/05B/10G
208	4822 450 61479	for /40B/45B
209	4822 321 10457	for /00B/40B/45B
209	4822 321 10251	for /05B
209	4822 321 10523	for /10G
211	4822 444 50603	
212	4822 325 50176	
213	4822 325 50177	
214	4822 466 92251	
216	4822 410 60604	
217	4822 358 10115	
218	4822 528 81329	
219	4822 321 22832	
221	4822 444 30419	for /00B/05B/10G
221	4822 444 60652	for /40B/45B
222	4822 444 60568	
223	4822 532 51756	
224	4822 466 92257	
226	4822 402 61207	
227	4822 520 40177	
228	4822 530 80503	
229	4822 691 30209	
231	4822 528 90638	
232	4822 402 51196	
233	4822 492 51902	
234	4822 466 61587	
236	4822 492 52094	
237	4822 402 61252	
238	4822 402 61253	
239	4822 402 50276	
242	4822 492 32883	
243	4822 528 70651	
244	4822 361 21258	
246	4822 464 50763	
247	4822 492 70332	
248	4822 492 52123	
502	4822 462 41683	Front foot for /40B/45B
502	4822 462 41715	Rear foot for /40B/45B
503	4822 444 30404	For 40B/45B



EXPLODED VIEW

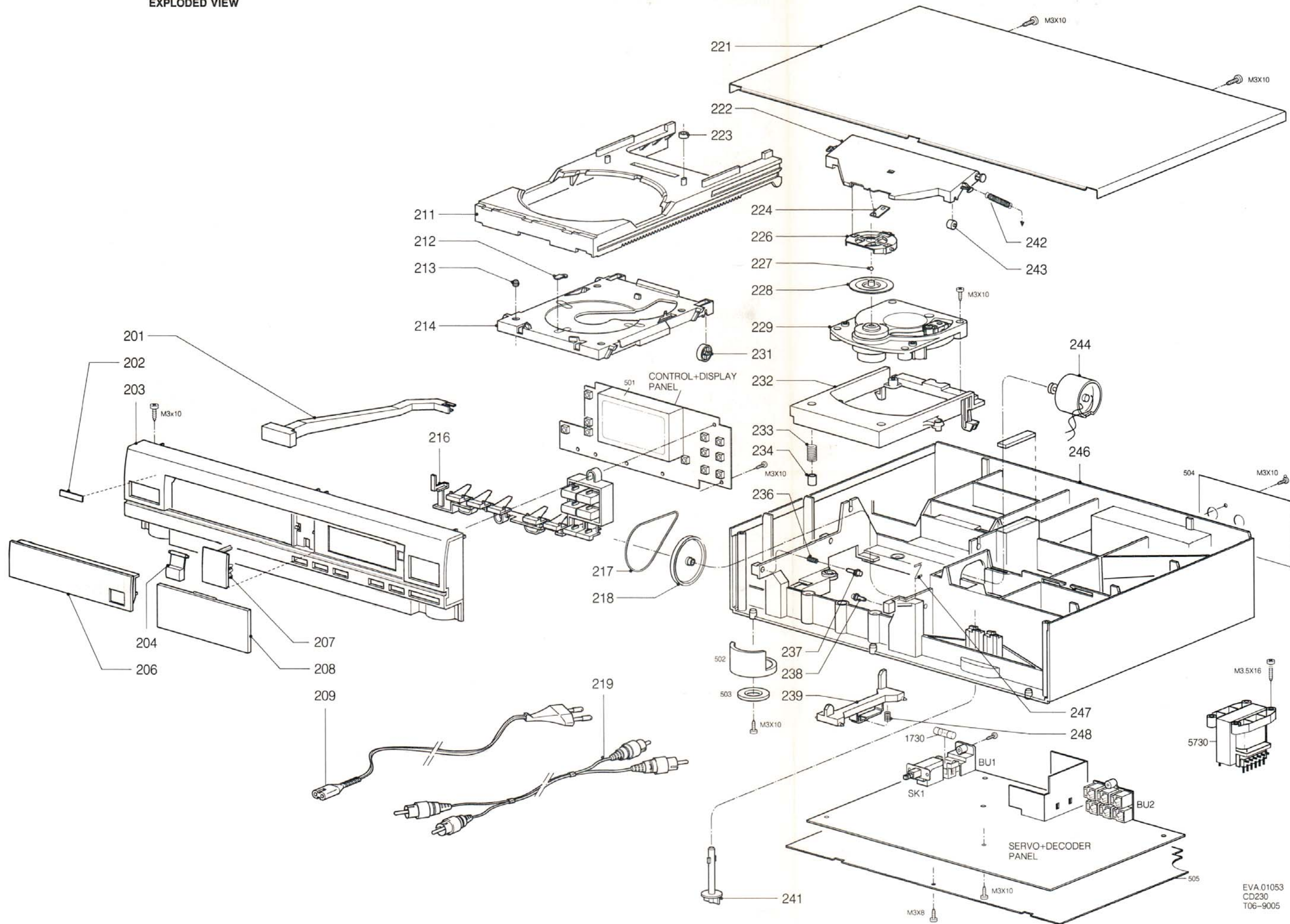

TROUBLE SHOOTING (FAULT FINDING TREE)

Follow the path of the faultfinding tree beginning at the top left. Perform the actions you come across in the various blocks. Look at the various side branches to find out if the information you see there applies to your problem. If, for instance, you find the indication "display", this means that no picture appears on the display.

If you establish this fault, follow the branch and perform the recommended actions. Check the signals mentioned. In a number of branches further reference is made to measurements you could carry out. These measurements are explained in several tables further on in this manual.

START-UP PROCEDURE

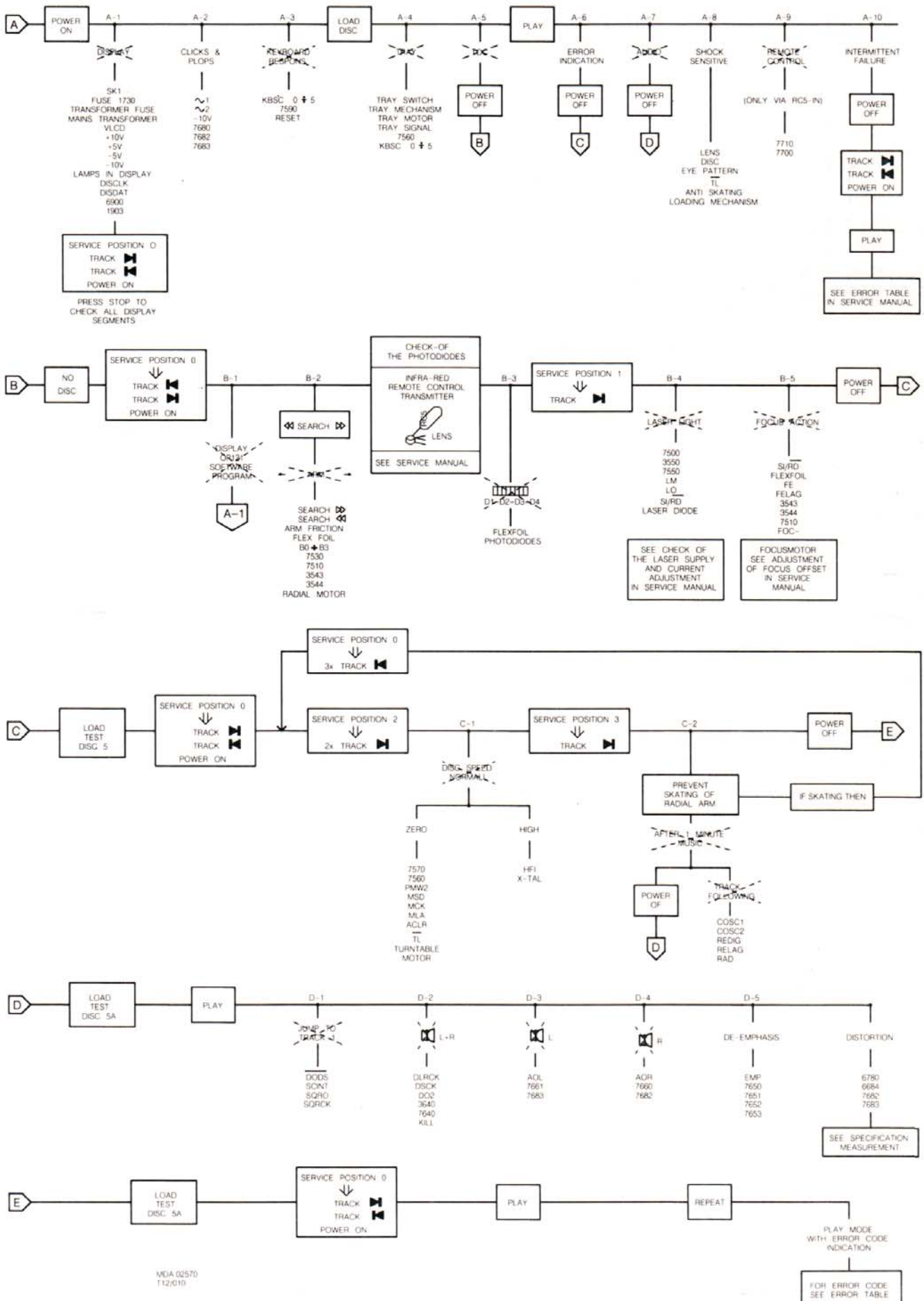



Step	Signal	Mode					Remarks
1	D2 D1 D3 D4	power on	   	-	-	signal 4:6:7:8	Signal depends on Distance lens ↔ IR LED of remote control

T-22407A

B-4 CHECK OF LASER SUPPLY

The laser, the lasersupply plus the monitor diode form a feedback system. A defect in the lasersupply may result in the destruction of the laser. If, in that case, the laser is replaced, (= complete D.C.M.-unit) the new laser will also become defective. However, it is impossible to check and repair a feedback system if a link is missing. For this reason the laser supply can be checked with the replacement circuit for laser assembly.

Step	Signal	Mode			Remarks
1	LO	serv. pos. 2 SK		1.8<V <2.3	 REPLACE CIRCUT FOR LASER ASSEMBLY CONNECT DIRECTLY TO PANEL THE LED EMITS LITTLE LIGHT LED GREEN # 5 CQYR 5322 100 32182 PRO 05036 128/845
	LM			170<mV <220	
2	LO	serv. pos. 2 SK		1.8<V <2.3	 REPLACE CIRCUT FOR LASER ASSEMBLY CONNECT DIRECTLY TO PANEL THE SWITCH SYSTEM MUST BE IN THE SAME POSITION OF CORRECT BEING THROUGH THE LED WHEN SK IS OPEN AND WHEN SK IS CLOSED THE LED EMITS THE LIGHT PRO 05040 128/845
	LM			170<mV <220	
3	LO	Power on		0V ± 0.2V	No light

After opening SK the led will emit more light for a short moment.

T-22407B

B-4 LASER CURRENT ADJUSTMENT

STEP	SIGNAL	MODE					REMARKS
1	--	POWER OFF	--	--	--	--	CHECK IF FLEX-FOIL IS PROPERLY CONNECTED
2	--	POWER OFF		R3555	1kΩ +10% -0	--	PRE ADJUSTMENT OHMIC VALUE
3	--	POWER OFF	--	R3515	--	--	SET TO MID-POSITION
4	LASER CURRENT VOLTAGE ACROSS R3500	TEST DISC 5A PLAY		--	≥15mV	--	IF < 15mV THEN GO TO STEP 3 AND SET R3515 TO 1/4 OR 3/4. TRY AGAIN
5	LASER CURRENT VOLTAGE ACROSS R3500	TEST DISC 5A PLAY		R3555	50mV	--	--
6	FE-LAG	TEST DISC 5A TRACK 1 PLAY		R3515	400mV	--	FINE ADJUSTMENT

B-5 ADJUSTMENT OF FOCUS-OFFSET

MDA 02565  
T-19/009

Step	Signal	Mode					Remarks
1	-	Power on no disc	-	R3568	-	-	adjust for optical mid-position of the focus motor
2	FE LAG	Play Test disc 5 Track 1	27	R3568	400mV ± 40 mV DC	-	fine adjustment

T-22407D



**ERROR TABLE**

**System errors**

- 02>Err:** TL pulse is missing during start-up. Check the TL signal, the HF-signal and the Photodiode signal processor. (Starting error)
- 03>Err:** Lead-in track not found. Check the disc used. Check also that the radial arm rests against the inside. Check the RE-dig signal and the Radial error processor. (Starting error)
- 04>Err:**Focus lost while starting: Check the focus offset
- 05>Err:** TL pulse is low for more than 50 msec. Check the disc used. Check the HF-in signal and the photodiodes (Error during PLAY)
- 06>Err:** No TL pulse received within 0.5 sec. in case of track jumping. Check the RE-lag circuit. (Error during SEARCH or NEXT/PREVIOUS)
- 07>Err:** Subcode error. In case of track loss during play the information of the subcode is used to determine the place of the last information that was still well readable. In case of an interruption of HF or other signals, this will lead to Er 07. (Error during PLAY)
- 08>Err:** TOC error (Table of Contents). Check the quality of the disc used. Check the initial speed of the turntable motor and the motor control. Check also that the radial arm rests against the inside. (Starting error)

**Operating errors**

- 11>Err:** CDI Disc
- 30>Err:** NEXT when repeat is off.
- 31>Err:** PREVIOUS when repeat is off.
- 32>Err:** INDEX selected when no track selected.
- 33>Err:** Selected index does not exist on this CD.
- 34>Err:** Review error: no program.
- 35>Err:** Program memory full.
- 36>Err:** Programmed track is non existing on this CD.
- 37>Err:** Selected track is non existing on this CD.
- 38>Err:** Program during scan while track is not known
- 39>Err:** Program during scan while track is already programmed
- 40>Err:** 10 key when programmed or no valid track selection
- 41>Err:** Track selected while programmed
- 50>Err:** EDIT pressed while in play mode
- 51>Err:** 0 minutes cassette time for edit
- 52>Err:** Not-allowed key pressed while in edit
- 53>Err:** No track possible to play in edit
- 54>Err:** A B key pressed while not in play
- 60>Err:** Fast forward bound
- 61>Err:** Fast reverse bound
- 62>Err:** Fast forward/reverse during scan
- 63>Err:** Index +/- pressed during scan

**CIRCUIT DIAGRAM POWER SUPPLY**

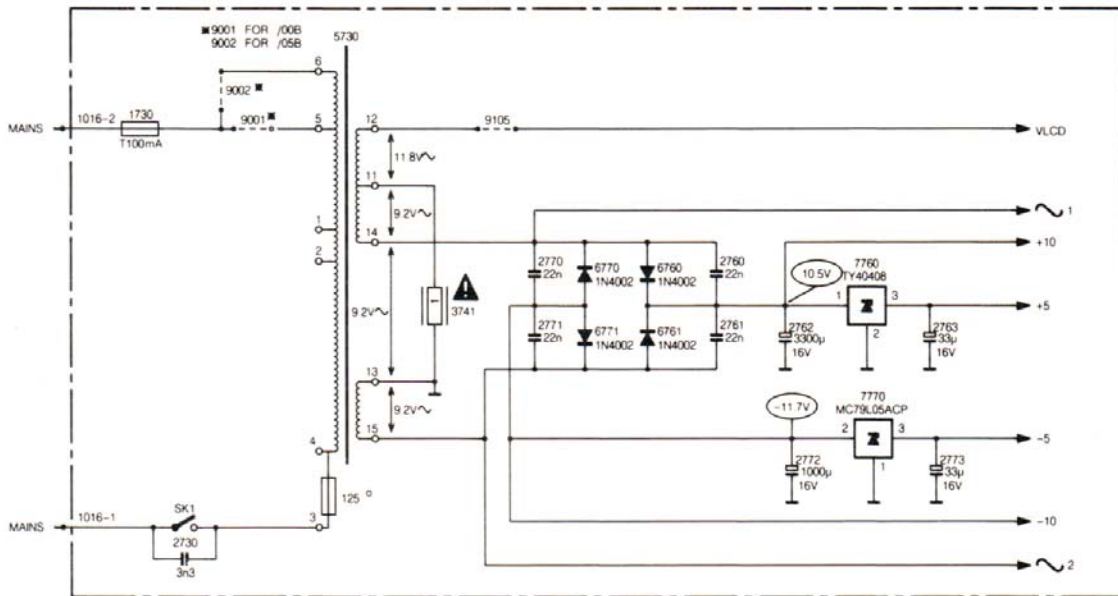

PRS.06456  
128/009

AGC	-Automatic Gain Control	Rosc	-Resistor wobble oscillator
B0-B3	-Control bits for radial circuit	Rwob	-Wobble generator input
BEQ	-Equalizer reference current input	RE1	-Radial error signal 1 (summation of amplified currents $D_3$ and $D_4$ )
BGC	-DC and LF gain control reference input	RE2	-Radial error signal 2 (summation of amplified currents $D_1$ and $D_2$ )
Cosc1	-Capacitor wobble oscillator	RE dig	-Radial error digital
Cosc2	-Capacitor wobble oscillator	RE lag	-Radial error signal for LAG network
DEC	-Decoupling input of inkruat bypass	Sc	-Starting up capacitor input
DET	-HF detector voltage input	Si/RD	-On/off control for laser supply and focus circuit. Ready signal, Starting up procedure succesful.
DIV4	-Divide by 4 input	TL	-Track loss output signal
DODS	-Drop out detector suppression	TTM	-Control voltage for turntable motor
D1÷4	-Photodiode currents	Vext-	-Supply connection
FE	-Focus error signal	Vext+	-Supply connection
FE lag	-Focus error signal for LAG network		
HFD	-HF detector output for Decoder		
HF-in	-HF current input to HF amplifier		
HF-out	-HF amplifier and equalizer voltage output		
LM	-Laser monitor diode input		
LO	-Laser amplifier current output		
offset IN	-Offset control input		
offset OUT	-Offset control output		
PLLH	-PLL on hold output		
RADout	-output of RE2-RE1 input		
RE	-Radial error signal (Amplified $RE_2$ - $RE_1$ currents)		
ACLR	- $\mu$ Processor interface register clear input	SBCU	- Subcode Uch output
AOR	- Audio out right	SBCV	- Subcode Vch output
AOL	- Audio out left	SBCW	- Subcode Wch output
APTR	- DAC sampling clock Rch	SBCQ	- Subcode Qch output
APTL	- DAC sampling clock Lch	SBCR	- Subcode Rch output
ACRCY	- Clock accuracy input	SBCS	- Subcode Sch output
BCK	- Clock input	SBCT	- Subcode Tch output
C423	- Clock output 4.2336 MHz	SCCK	- Shift clock input for serial subcode output
C846	- Clock output 8.4672 MHz	SCINT	- Interrupt output of subcode Q
C8MO	- 1/2 divider output	SCOE1	- Enable input for subcode channels T-W
C16MI	- 1/2 divider input	SCOE2	- Enable input for subcode channels P-S
CAS	- Column address strobe signal output to RAM	SCOR	- Subcode sync output
CRCF	- Subcode Q CRC check flag output	SQRCK	- Subcode Q register clock
DASEL 1-4	- DAC Interface format select	SQRO	- Subcode Q register output
DATA	- Serial data input	TEST 1	- Test control input (normal "0")
DLRCK	- Lch/Rch clock	TLC	- Output from slice level control
DO 1	- Dual DAC Rch serial data output	Vref	- Reference offset voltage
DO 2	- Dual DAC Lch serial data output	WDCK	- Word clock to DAC or APTL clock
DOFK	- OSC frame clock output 7.35 kHz (duty = 50 %)	WE	- Write enable output to RAM
DOSEL	- Data bit select	WS	- Word select clock (L/R)
DOTX	- Digital interface output	X-out	- Crystal oscillator output
DRD	- Disc rotation down signal	X-in	- Crystal oscillator input
EFFK	- EFM frame clock output		
EMP	- Emphasis flag output		
EST1	- Error status 1 (Error detected at C1)		
EST2	- Error status 2 (Error to be interpolated detected at C2)		
FSCK	- Clock output 44.1 kHz (fs)		
HFD	- High frequency signal detect		
HFI	- High frequency signal input		
IREF	- Reference current input		
LOCK/DRD	- Lock status/Disc rotation down signal		
LPF	- PLL loop filter		
LRCK	- Lch/Rch clock to DAC or APTR clock		
MCK	- $\mu$ Processor interface clock input		
MLA	- $\mu$ Processor interface latch input		
MSD	- $\mu$ Processor interface data input		
PWM1	- Turntable motor signal		
PWM2	- Turntable motor signal		
RAD0-7	- Address outputs to RAM		
RAS	- Row address strobe signal output to RAM		
RDB1-4	- Data I/O to RAM		



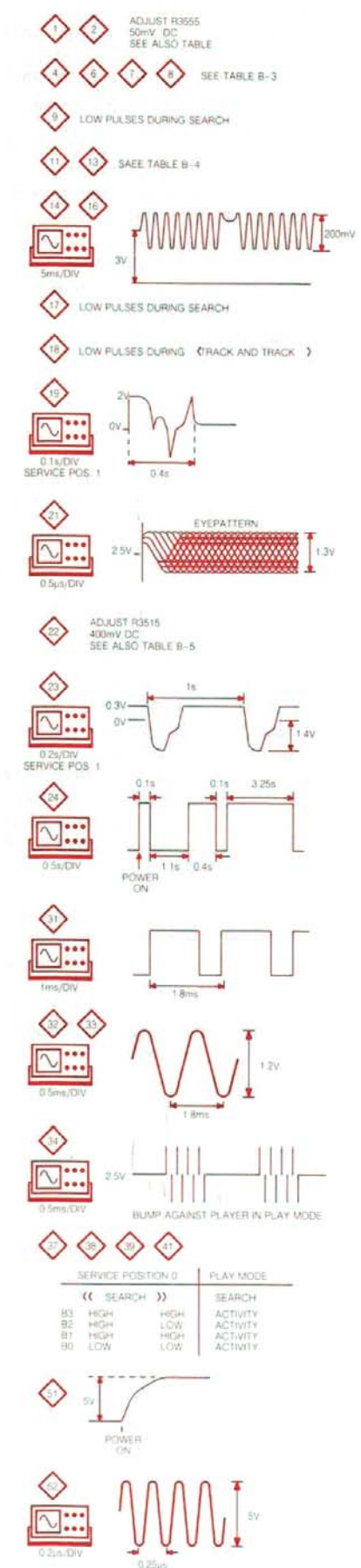
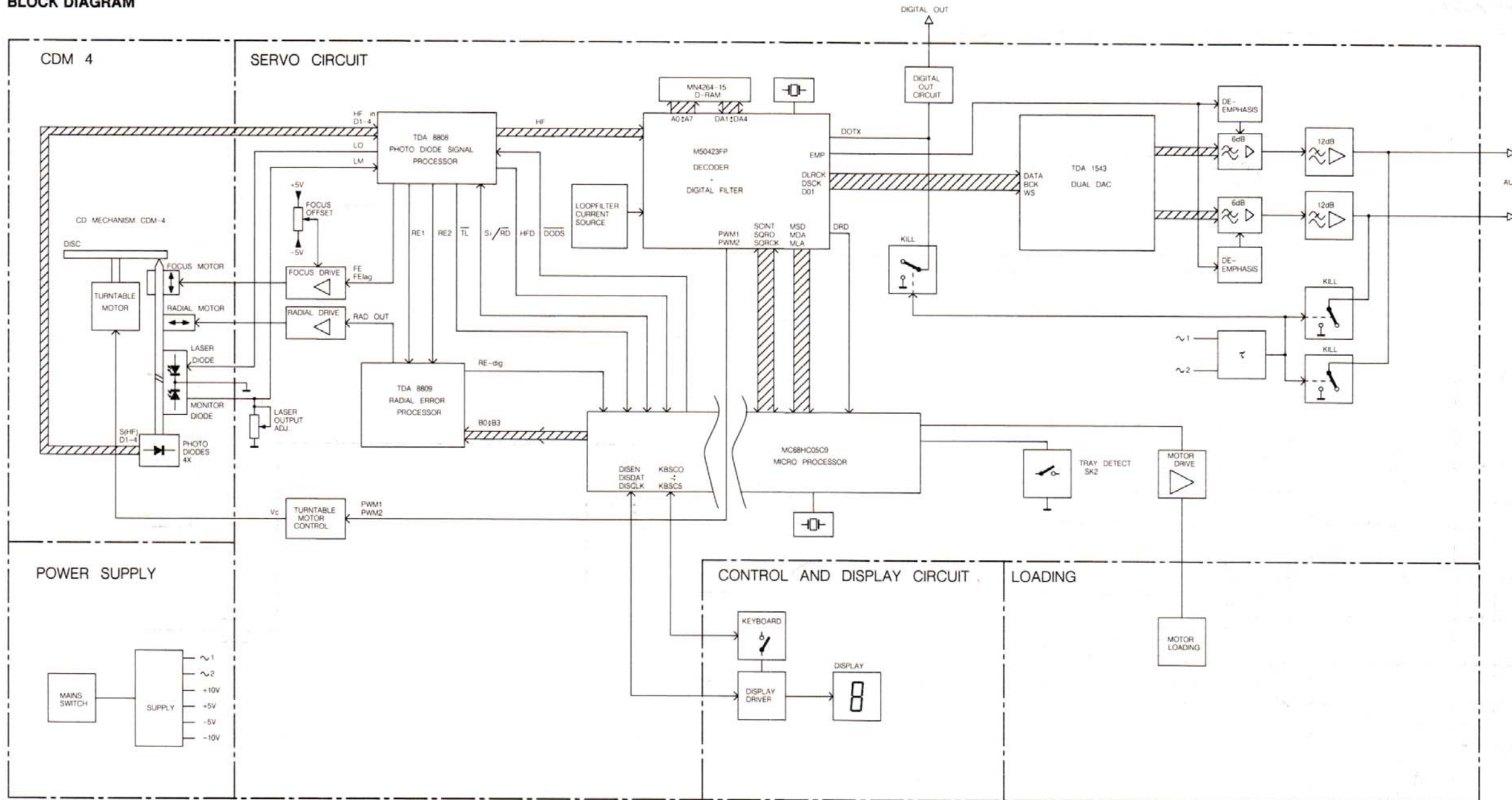

SERVICE POSITION 0		PLAY MODE	
BS	HIGH	HIGH	ACTIVITY
BE	HIGH	LOW	ACTIVITY
BT	HIGH	HIGH	ACTIVITY
BO	LOW	LOW	ACTIVITY

PRS 06476  
T02/007



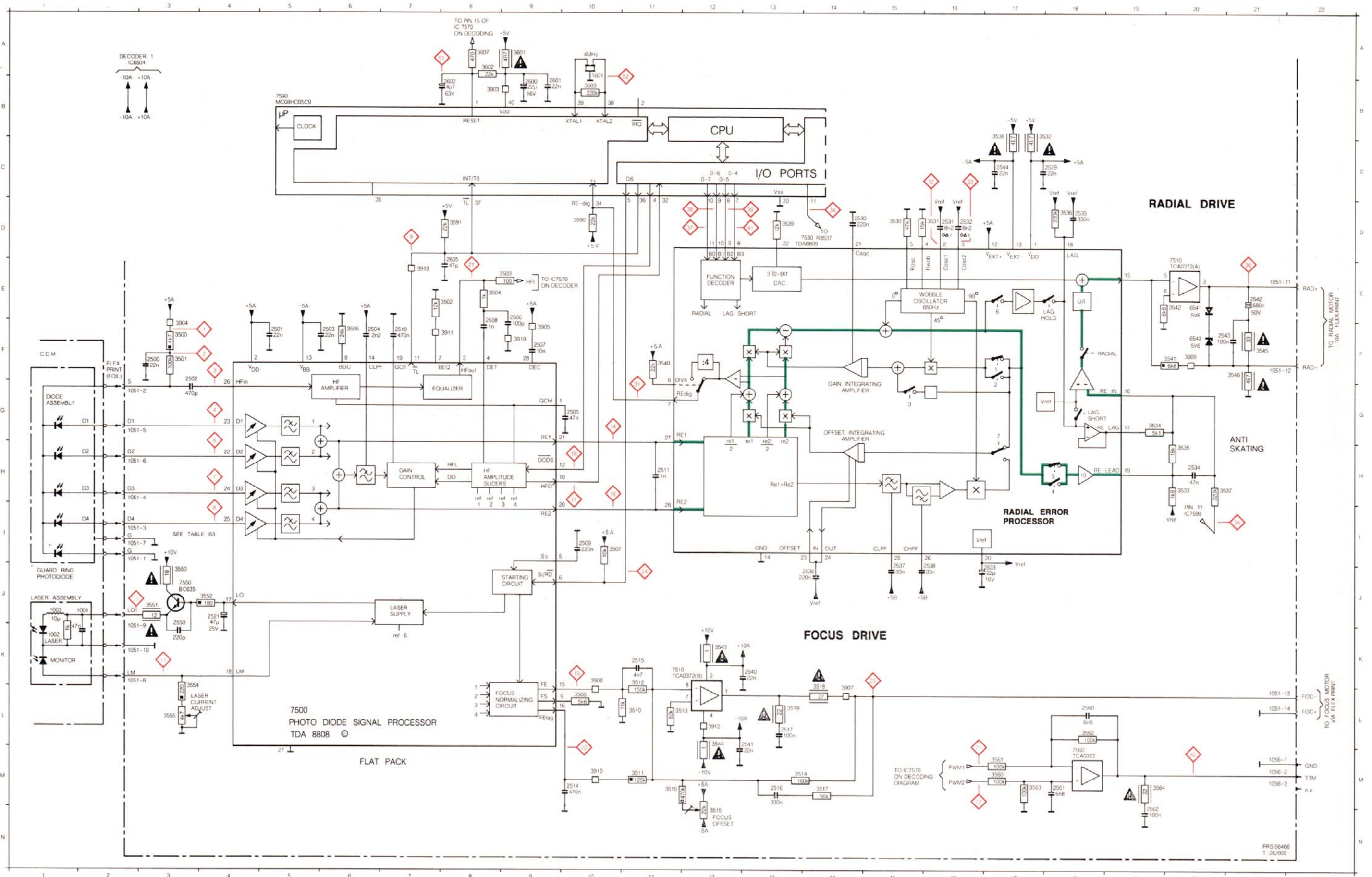

- 1001 J1
- 1002 K1
- 1003 J1
- 1601 A10
- 2500 F3
- 2502 G3
- 2501 F5
- 2503 F6
- 2504 F6
- 2505 G10
- 2506 E9
- 2507 F9
- 2508 F8
- 2509 I10
- 2510 F7
- 2511 H11
- 2514 M10
- 2515 K11
- 2516 M13
- 2517 L13
- 2521 J4
- 2530 D14
- 2531 D16
- 2532 D16
- 2533 J17
- 2534 H20
- 2535 D18
- 2536 J14
- 2537 J15
- 2538 I16
- 2539 C18
- 2540 K13
- 2541 L13
- 2542 E21
- 2543 F20
- 2544 C17
- 2550 K3
- 2560 L18
- 2561 M18
- 2562 N19
- 2600 B9
- 2601 B9
- 2602 B8
- 2605 E8
- 3500 F3
- 3501 F3
- 3502 E8
- 3503 E9
- 3504 E8
- 3505 F8
- 3506 L10
- 3507 I10
- 3510 L11
- 3511 M11
- 3512 K11
- 3513 L11
- 3514 M13
- 3515 N12
- 3516 M11
- 3517 M14
- 3518 L14
- 3519 L13
- 3530 D15
- 3531 D16
- 3532 B17
- 3533 H20
- 3534 G19
- 3535 H20
- 3536 D18
- 3537 H20
- 3538 B17
- 3539 D13
- 3540 F11
- 3541 F20
- 3542 F20
- 3543 K12
- 3544 L12
- 3545 F21
- 3546 F21
- 3550 J3
- 3551 J3
- 3552 J4
- 3554 L3
- 3555 L3
- 3560 M17
- 3561 M17
- 3562 L18
- 3563 M17
- 3602 A8
- 3603 B10
- 3607 A8
- 3903 B8
- 3904 F3
- 3905 F9
- 3906 K10
- 3907 L14
- 3908 F20
- 3910 M10
- 3911 F8
- 3912 L12
- 3913 E7
- 3919 F9
- 6540 F20
- 6541 E20
- 7510 E20
- 7510 K11
- 7530 D11
- 7550 J3
- 7560 M18
- 7590 B5



MAIN PANEL SOLDERSIDE

83 B12	2508 F10	2543 F12	2585 F1	2662 C2	2773 A7	3532 D8	3561 G6	3603 E7	3656 D1	3681 A6	3910 G9	6683 B6	7661 D2	9014 E3	9037 G11	9060 B3	9082 D2	9103 B2
BU1 A11	2509 E11	2544 E10	2586 G5	2663 C2	3500 F12	3533 E12	3562 G7	3604 F6	3657 D3	3682 A6	3911 F10	6684 B5	7680 B6	9015 D5	9038 E8	9061 A8	9083 D8	9104 D2
BU2 A4	2510 E9	2550 H11	2600 E9	2664 C1	3501 F11	3534 E10	3563 G7	3605 E5	3658 D1	3683 B6	3912 H8	6760 B8	7682 C3	9017 D4	9039 E8	9062 A7	9084 C7	9105 C8
SK1 C12	2511 E11	2551 H11	2601 E7	2665 C3	3502 F11	3535 E9	3564 G7	3607 F7	3659 D3	3684 B4	3913 E7	6761 B8	7683 C4	9018 G3	9040 B5	9063 G6	9085 E8	9106 G4
1017 A11	2514 H11	2560 G6	2602 F7	2666 C2	3503 F10	3536 E9	3570 F5	3610 F7	3660 D1	3686 B4	3914 D5	6770 B8	7700 F8	9019 E2	9041 G6	9064 B4	9086 D8	9107 F8
1051 G11	2515 G11	2561 G7	2605 E6	2667 C2	3504 E10	3537 E9	3571 G3	3611 F7	3661 E2	3687 E4	3917 E3	6771 B8	7710 D5	9020 G1	9042 E8	9065 F4	9087 D5	9108 B3
1058 G8	2516 G12	2562 G8	2610 G6	2668 C1	3505 F9	3538 B7	3572 E4	3612 F7	3662 D1	3700 F7	3918 B3	7500 F10	7770 A8	9022 E12	9043 E8	9066 C2	9088 F7	9109 E1
1059 D4	2517 G8	2570 E4	2611 G7	2669 D2	3506 F9	3539 F11	3573 F5	3613 G7	3663 D3	3701 F8	3919 F9	7510 G8	7770 A8	9023 G11	9044 F7	9067 H2	9089 D5	
1060 D5	2530 E10	2571 E3	2612 G6	2670 B2	3507 F9	3540 D9	3574 F4	3614 G7	3664 C1	3702 F8	3921 F2	7530 E10	9000 E5	9024 H10	9045 B7	9068 F10	9090 F10	
1061 G2	2531 D10	2572 G3	2630 H5	2671 C3	3510 G9	3541 G10	3580 G5	3617 G6	3665 C3	3710 C7	3922 B5	7550 H11	9001 C11	9025 H4	9046 D7	9069 G12	9091 E7	
1062 F7	2532 D10	2573 G3	2631 A5	2680 A5	3511 G8	3542 G9	3581 G3	3630 G5	3666 C1	3711 D4	3925 A2	7560 G7	9002 C11	9026 H3	9047 F2	9070 D9	9092 C7	
1570 G3	2533 E11	2574 E4	2632 A4	2681 A5	3512 G11	3543 H8	3583 E3	3631 G6	3667 C2	3741 C8	3926 H5	7570 F3	9003 C3	9027 F1	9048 H2	9071 F9	9093 H10	
1601 D7	2534 D9	2575 E4	2640 E1	2682 B5	3513 G8	3544 H8	3585 F2	3632 H6	3668 C2	3900 G4	3927 G2	7575 G2	9004 E2	9028 E2	9049 B5	9072 G8	9094 B5	
2500 F11	2535 D9	2576 E3	2641 E1	2730 C12	3514 G10	3545 F12	3586 G2	3640 E2	3669 D2	3902 E2	3928 B10	7590 E6	9005 E4	9029 E3	9050 C1	9073 C8	9095 G2	
2501 F10	2536 E12	2577 E3	2650 C1	2760 B8	3515 D7	3546 G12	3587 G4	3641 E2	3670 C3	3903 E7	6540 G12	7630 H6	9006 G9	9030 E9	9051 G5	9075 D2	9096 E4	
2502 F11	2537 E11	2578 F2	2651 D3	2761 B8	3516 D9	3547 H10	3590 D7	3650 E1	3671 C1	3904 E11	6541 G12	7640 E2	9007 F11	9031 E11	9052 E4	9076 E10	9097 F11	
2503 F10	2538 E11	2579 G4	2652 D1	2762 C7	3517 G11	3548 H10	3591 D7	3651 E1	3672 B3	3905 F11	6570 F5	7650 F1	9008 G11	9032 E10	9053 E4	9077 E9	9098 F10	
2504 F9	2539 D10	2582 G3	2653 D3	2763 B7	3518 G9	3552 H10	3592 E5	3652 F2	3673 C5	3906 H10	6590 F5	7651 F1	9009 F9	9033 F10	9054 G4	9078 E9	9099 B7	
2505 F11	2540 G8	2582 E3	2659 E2	2770 B8	3519 G8	3554 G9	3593 F5	3653 B6	3674 B3	3907 G10	6680 A9	7652 D1	9011 F7	9034 E9	9055 B8	9079 H10	9100 C4	
2506 E9	2541 G8	2583 E3	2660 D1	2771 B8	3520 D10	3555 H9	3601 D8	3654 D1	3675 C5	3908 H10	6681 A9	7653 D3	9012 F5	9035 F8	9056 A7	9080 G5	9101 F5	
2507 F10	2542 F12	2584 G2	2661 D2	2772 B8	3521 D10	3560 G6	3602 E7	3655 D3	3680 A8	3909 G11	6682 A6	7660 C1	9013 B2	9036 F9	9058 D7	9081 F5	9102 G5	

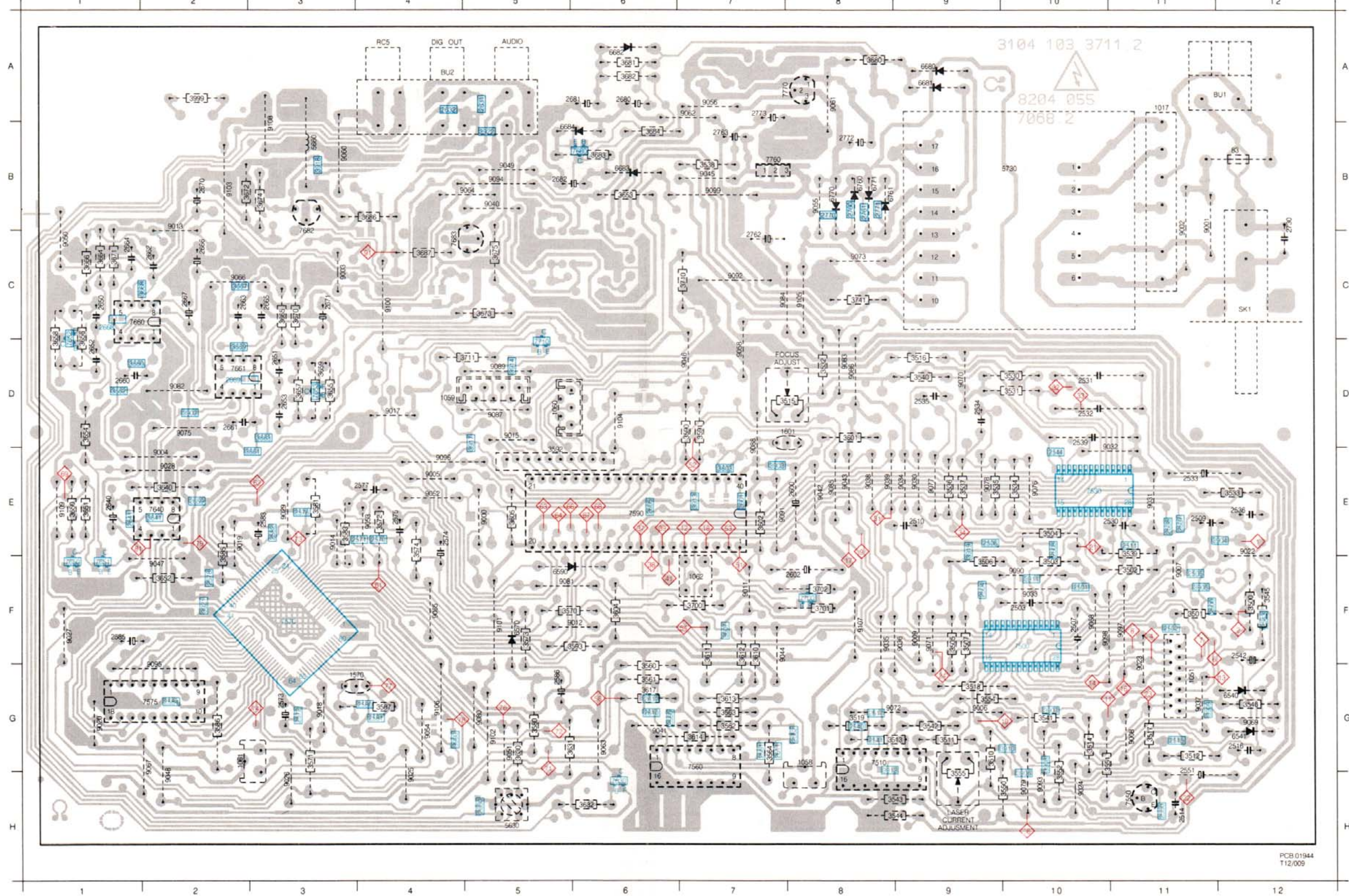



MAIN PANEL COMPONENT SIDE

83 B1	2506 E4	2539 D3	2578 F11	2641 E12	2681 A7	3510 G4	3539 F2	3571 G10	3607 F6	3657 D10	3680 A5	3907 G3	6570 F8	7630 H7	9004 E11	9026 H10	9045 B6	9066 C11	9086 D5	9105 C5
BU1 A1	2507 F3	2540 G5	2580 G9	2650 C12	2682 B8	3511 G4	3540 D4	3572 E9	3610 G6	3658 D12	3681 A7	3908 H3	6590 F8	7640 E11	9005 E9	9027 F12	9046 D6	9067 H11	9087 D8	9106 G9
BU2 A9	2508 F3	2541 G5	2581 G9	2651 D10	2683 C1	3512 G2	3541 G3	3573 F8	3611 G6	3659 D10	3682 A7	3909 G2	6580 A4	7650 F12	9006 G4	9028 E11	9047 F11	9068 F3	9088 E6	9107 F5
SK1 C1	2509 E2	2542 F1	2582 E10	2652 D12	2684 B5	3513 G4	3542 G4	3574 F8	3612 G6	3660 D11	3683 B7	3910 G3	6581 A4	7651 F12	9007 F2	9029 E10	9048 H11	9069 G1	9089 D8	9108 B10
1017 A2	2510 E4	2543 F1	2583 E10	2653 D10	2685 B5	3514 G3	3543 H4	3580 G8	3613 G6	3661 E10	3684 B7	3911 F3	6582 A7	7652 D12	9008 G2	9030 F4	9049 B9	9070 D4	9090 F3	9109 E12
1051 G2	2511 E2	2544 E3	2584 G11	2659 E11	2762 B6	3515 D5	3544 H4	3581 E10	3614 G6	3662 D12	3685 B9	3912 H4	6583 B7	7653 D10	9009 F4	9031 E2	9050 C12	9071 F4	9091 E6	
1058 G5	2514 H2	2550 H2	2585 F12	2660 D12	2763 B6	3516 D4	3545 F1	3583 E10	3617 G7	3663 D10	3687 C9	3913 E6	6584 B7	7660 C11	9011 F6	9032 E2	9051 G8	9072 G4	9092 C6	
1059 D9	2515 G2	2551 H2	2586 G8	2661 D11	2770 B5	3517 G2	3546 G1	3585 F11	3620 G8	3664 C12	3700 F6	3914 D8	6760 B5	7661 D11	9012 F7	9033 F3	9052 E9	9073 C5	9093 H3	
1050 D8	2516 G1	2550 G7	2600 E5	2662 C11	2771 B5	3518 G4	3550 H4	3586 G11	3621 G8	3665 C10	3701 F5	3917 F8	6761 B5	7662 B7	9013 B11	9034 E4	9053 E9	9074 E3	9094 B8	
1061 G11	2517 G5	2561 G6	2601 E6	2663 C11	2772 B5	3519 G5	3551 H3	3587 G9	3622 H7	3666 C12	3702 F5	3918 B10	6770 B5	7662 C10	9014 E10	9035 F5	9054 G9	9075 D11	9095 C11	
1062 F6	2530 E2	2562 G5	2602 F5	2664 C12	2773 A6	3530 D3	3552 H3	3590 D6	3640 H11	3667 C11	3710 C6	3919 F4	6771 B5	7683 C9	9015 D8	9036 F4	9055 B5	9077 E4	9096 E9	
1570 G9	2531 D3	2570 E9	2605 E7	2665 C10	2774 B5	3531 D3	3554 G4	3591 D6	3641 E11	3668 C12	3711 D5	3921 F11	7500 F3	7700 F5	9017 D9	9037 G2	9056 A6	9078 E4	9097 F2	
1601 D5	2532 D3	2571 E9	2610 G7	2666 C11	2775 B5	3532 D5	3555 H4	3592 E8	3650 E12	3669 D11	3741 C5	3922 B8	7510 G5	7710 D8	9018 G10	9038 E5	9058 D6	9079 H3	9098 F3	
2500 F2	2533 E2	2572 G10	2611 G6	2667 C11	2776 B5	3533 E1	3560 G7	3593 F7	3651 E12	3670 C10	3900 G9	3923 A11	7520 E3	7760 B6	9019 E11	9039 E5	9060 B10	9080 G8	9099 B6	
2501 F3	2534 D4	2573 G10	2612 G7	2668 C12	2777 B5	3534 E3	3561 G7	3601 D5	3652 F12	3671 C12	3902 D11	3924 H8	7530 H2	7770 A6	9020 G12	9040 B8	9061 A5	9081 F7	9100 C9	
2502 F2	2535 D4	2574 E9	2630 H8	2669 D11	2778 B5	3535 E4	3562 G6	3602 E6	3653 B7	3672 B11	3903 E6	3925 B10	7560 G6	9000 E8	9021 E1	9041 G7	9062 A6	9082 D11	9101 F8	
2503 F3	2536 E1	2575 E9	2631 A8	2670 B11	2779 B5	3536 E4	3563 G6	3603 E6	3654 D12	3673 C8	3904 E1	3926 B3	7570 F10	9001 C2	9022 G2	9042 E5	9063 G7	9083 D5	9102 G8	
2504 F4	2537 E2	2576 E10	2632 A9	2671 C10	2780 B5	3537 E4	3564 G6	3604 F7	3655 D10	3674 B10	3905 F2	3927 G1	7575 G11	9002 C2	9023 H3	9043 E5	9064 B8	9084 C6	9103 B11	
2505 F2	2538 E2	2577 E9	2640 E12	2680 A7	2781 F4	3538 B6	3570 F7	3605 E8	3656 D12	3675 C8	3906 H3	3928 G1	7590 E7	9003 C10	9024 H9	9044 G6	9065 F9	9085 E5	9104 D7	

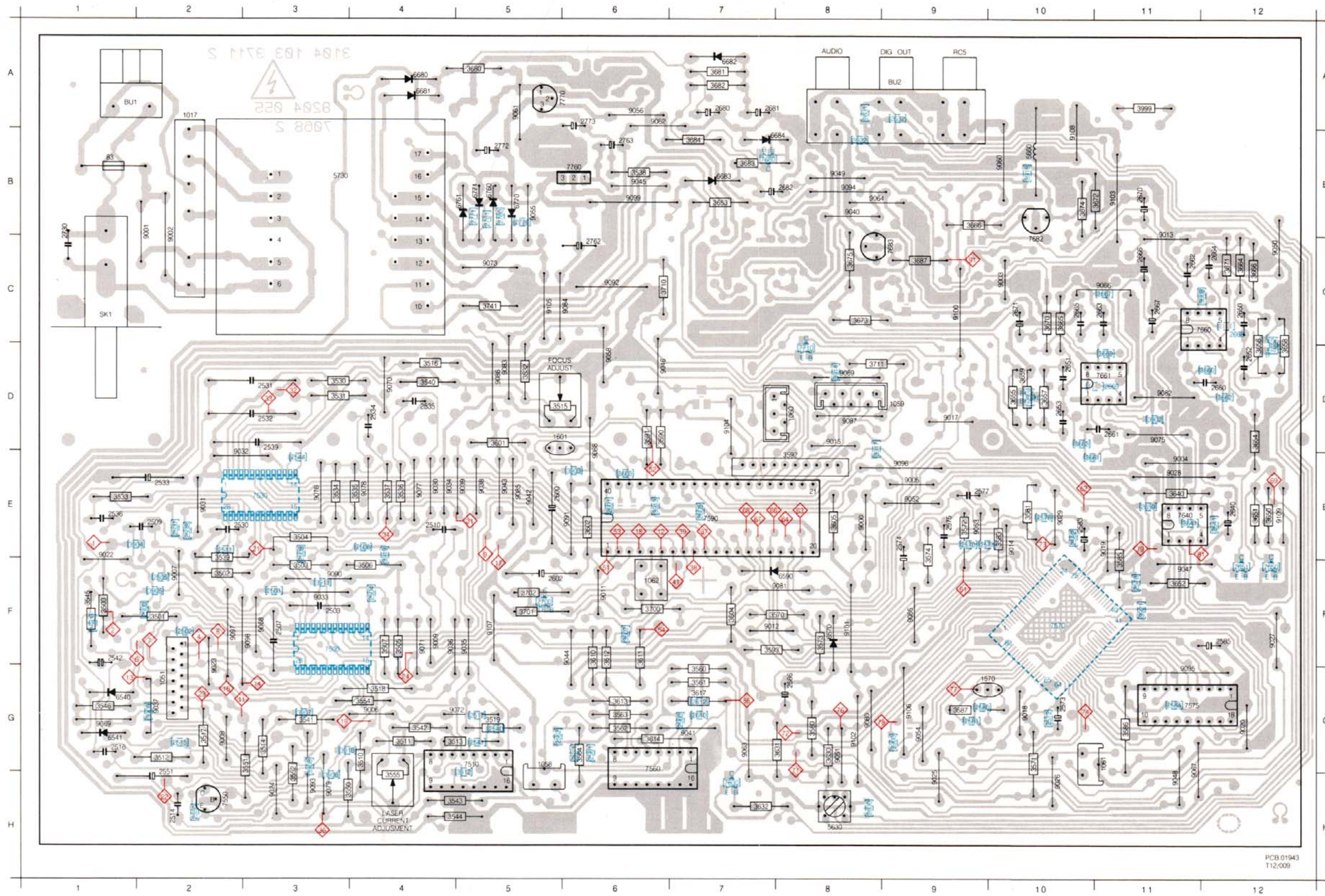



DECODER CIRCUIT DIAGRAM

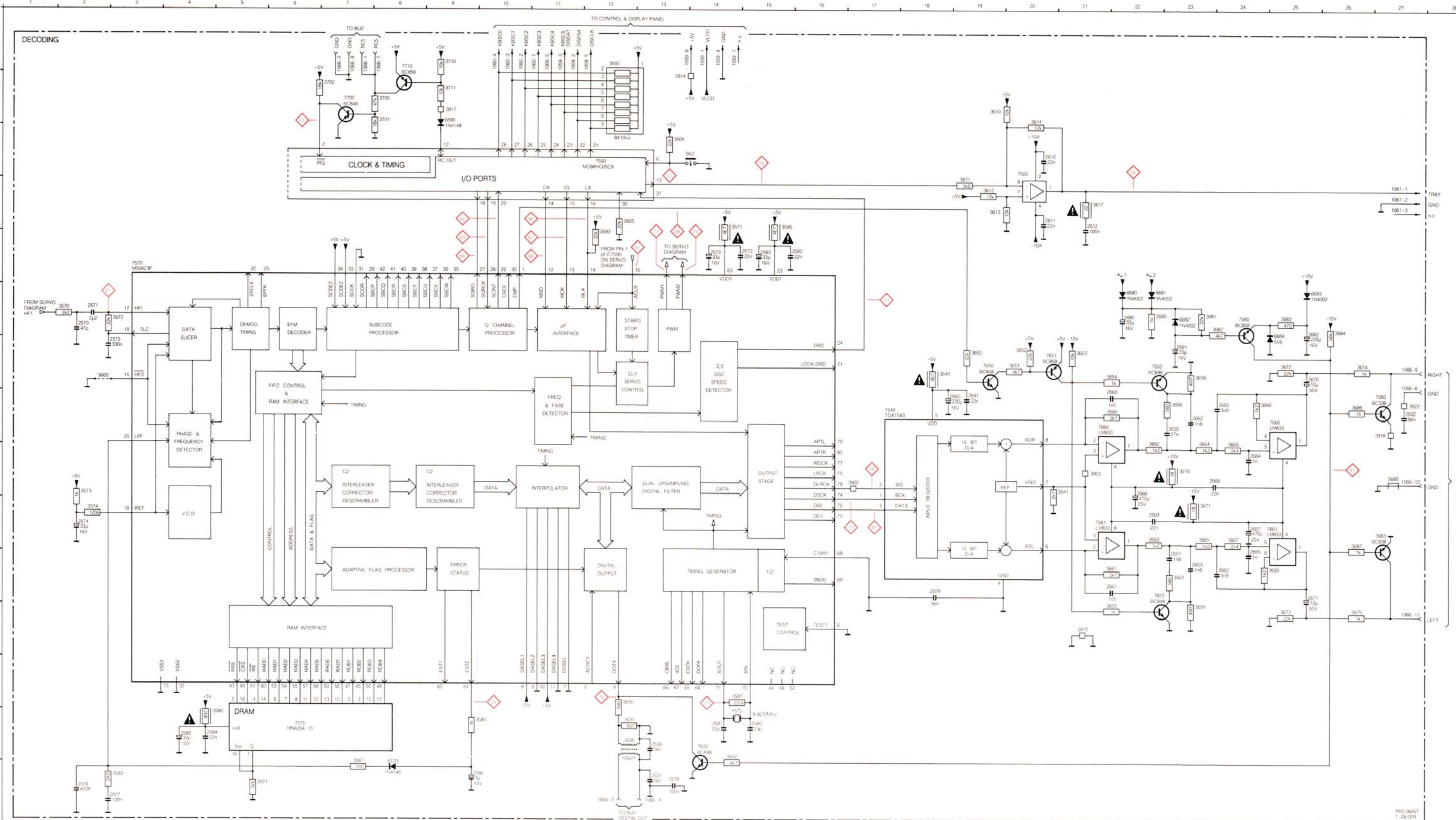

SK2	C13
1570	N1
2570	F2
2571	F2
2572	E15
2573	E14
2574	J2
2575	O3
2576	O2
2577	O3
2578	O13
2580	N15
2581	N1
2582	E15
2583	E15
2584	N4
2585	N4
2586	O9
2610	C20
2611	D20
2612	D21
2630	N13
2631	O13
2632	H27
2640	H18
2641	H19
2650	H23
2651	K23
2653	K23
2659	K18
2660	H22
2661	K22
2662	H24
2663	K24
2664	J24
2665	H24
2666	I22
2667	J24
2668	I23
2669	J22
2670	G25
2671	K25
2680	F22
2681	G23
2682	F25
3570	F2
3571	O14
3572	F3
3573	I2
3574	J2
3580	N9
3581	O7
3583	O3
3585	O15
3586	N4
3587	M4
3588	A12
3593	C13
3593	E12
3605	O12
3610	B19
3611	O19
3612	O19
3613	O19
3614	B20
3617	O21
3630	M12
3631	N12
3632	N14
3640	O18
3641	I21
3650	O19
3651	O20
3652	O20
3653	O21
3654	O22
3655	I22
3656	H23
3657	K23
3658	O23
3659	I23
3660	H22
3661	K22
3662	H22
3663	J22
3664	H23
3665	I23
3666	H24
3667	J24
3668	H24
3669	K25
3670	I23
3671	I23
3672	G25
3673	I25
3674	O26
3675	I26
3680	I22
3681	I23
3682	F24
3683	I25
3684	I26
3688	H20
3687	J26
3700	B8
3701	B8
3710	B9
3711	B9
3712	I1
3901	I1
3902	I1
3903	I1
3917	B9
3918	H27
3921	O6
3922	H27
5630	N12
5660	I27
6570	O8
6590	B9
6680	F22
6681	F22
6682	F23
6683	F23
6684	F25
6685	F25
7560	C20
7570	N6
7590	C12
7630	N14
7640	H17
7650	G19
7651	O20
7652	O22
7653	K22
7660	H21
7660	H25
7661	J21
7661	J24
7680	F24
7682	H27
7683	J27
7700	O7
7710	A8
8000	O2

DISPLAY PANEL CIRCUIT DIAGRAM

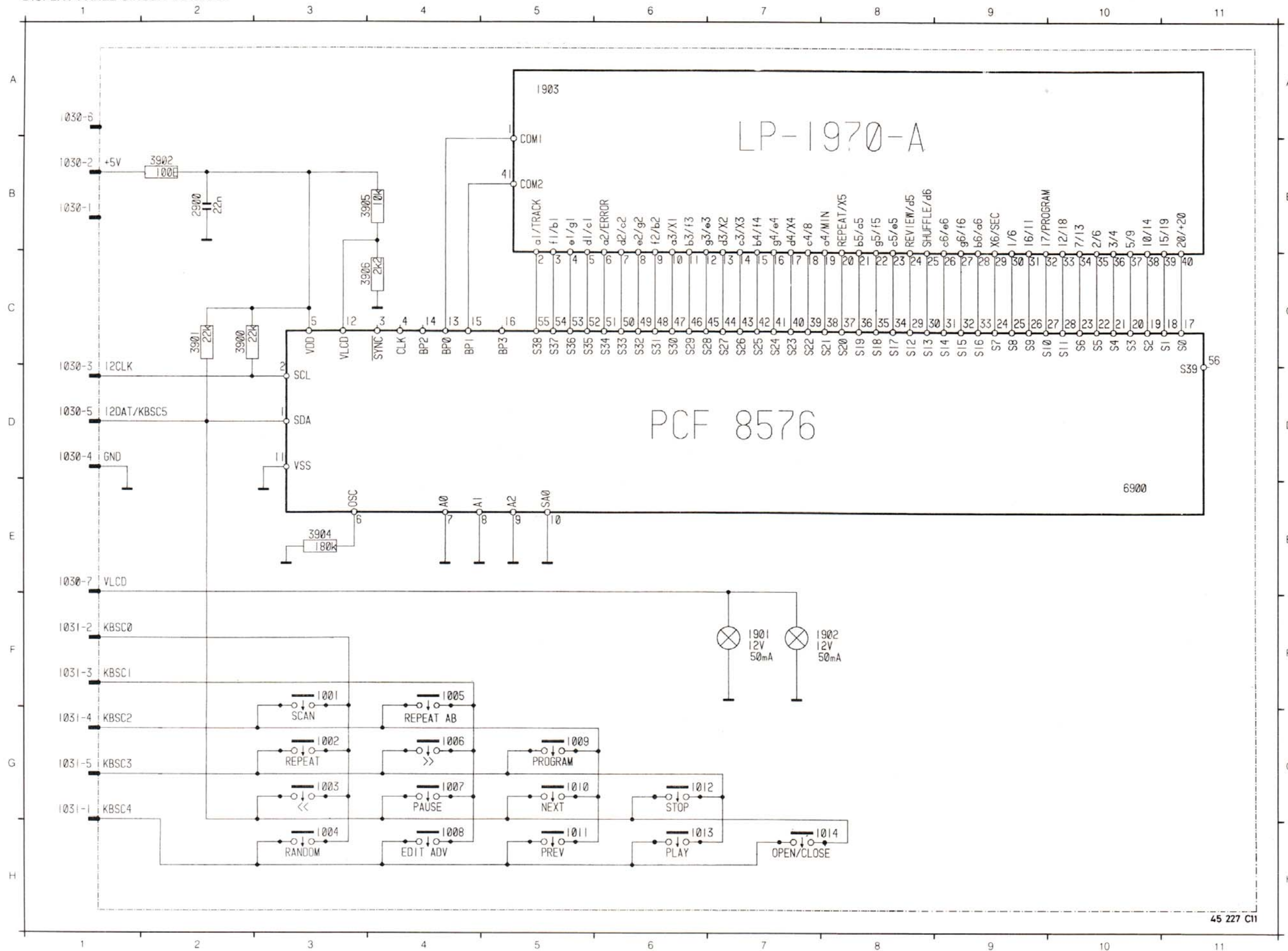

- 1001 F3
- 1002 G3
- 1003 G3
- 1004 H3
- 1005 F4
- 1006 G4
- 1007 G4
- 1008 H4
- 1009 G5
- 1010 G5
- 1011 H5
- 1012 G6
- 1013 H6
- 1014 H8
- 1901 F7
- 1902 F8
- 1903 A5
- 2900 B2
- 3900 C2
- 3901 C2
- 3902 B2
- 3904 E3
- 3905 B3
- 3906 C3
- 6900 E10

45 227 C11

## DISPLAY PARTSLIST

1001	4822 276 12465	Tact switch
1002	4822 276 12465	Tact switch
1003	4822 276 12465	Tact switch
1004	4822 276 12465	Tact switch
1005	4822 276 12465	Tact switch
1006	4822 276 12465	Tact switch
1007	4822 276 12465	Tact switch
1008	4822 276 12465	Tact switch
1009	4822 276 12465	Tact switch
1010	4822 276 12465	Tact switch
1011	4822 276 12465	Tact switch
1012	4822 276 12465	Tact switch
1013	4822 276 12465	Tact switch
1014	4822 276 12465	Tact switch
1901	4822 134 40918	LAMP
1902	4822 134 40918	LAMP
1903	4822 131 90132	LPH1970-1
2900	4822 122 10166	22nF 30% 16V
3900	4822 051 10223	22k $\Omega$ 2% 0,25W
3901	4822 051 10223	22k $\Omega$ 2% 0,25W
3902	5322 111 90091	100 $\Omega$ 2% 0,25W
3904	4822 050 21804	180k $\Omega$ 1% 0,6W
3905	4822 111 90249	10k $\Omega$ 2% 0,25W
3906	4822 116 53025	2,2k $\Omega$ 1% 0,6W
6900	5322 209 11129	PCF8576T



CONTROL AND DISPLAY PANEL

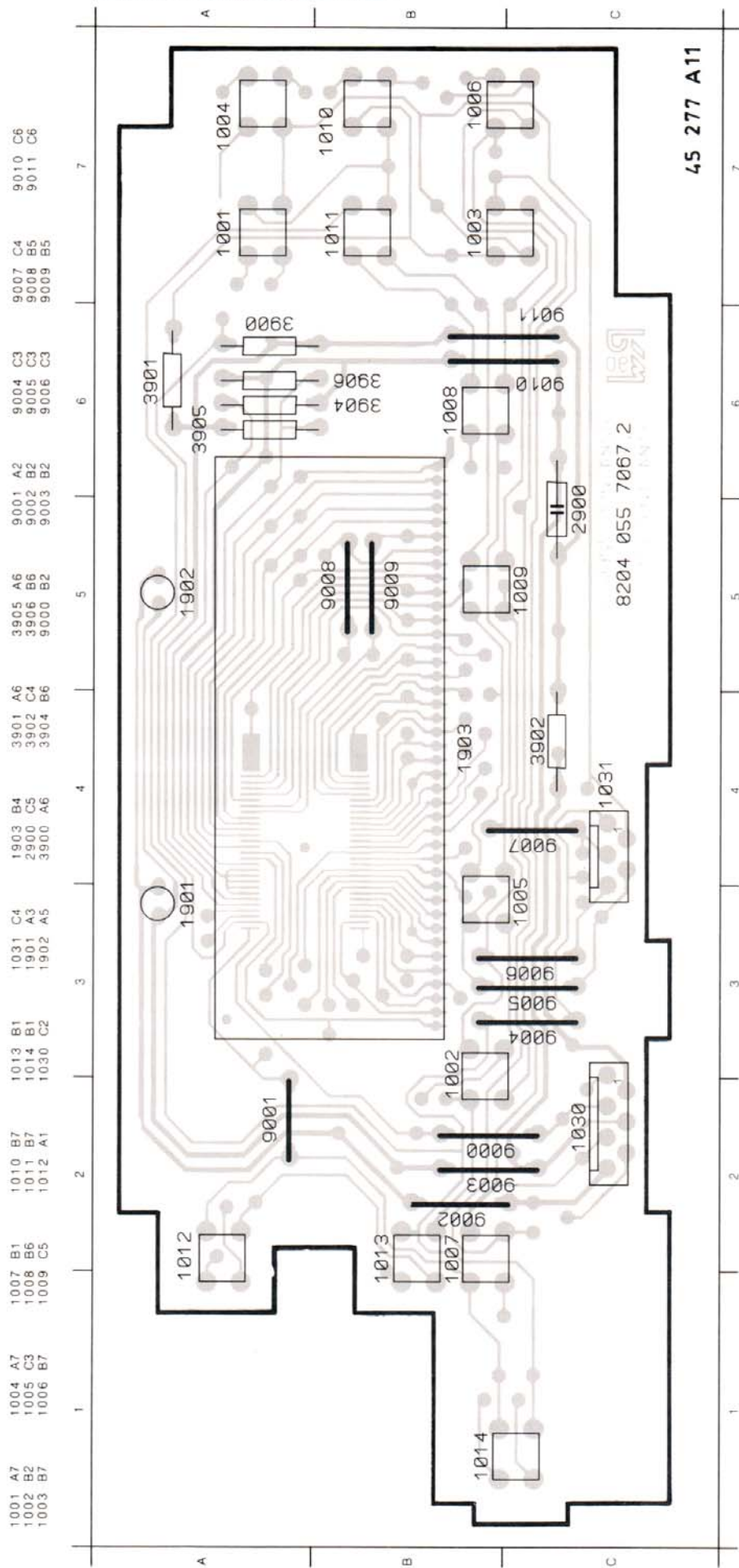

PRS 04340  
11/2/010

## WIRING DIAGRAM

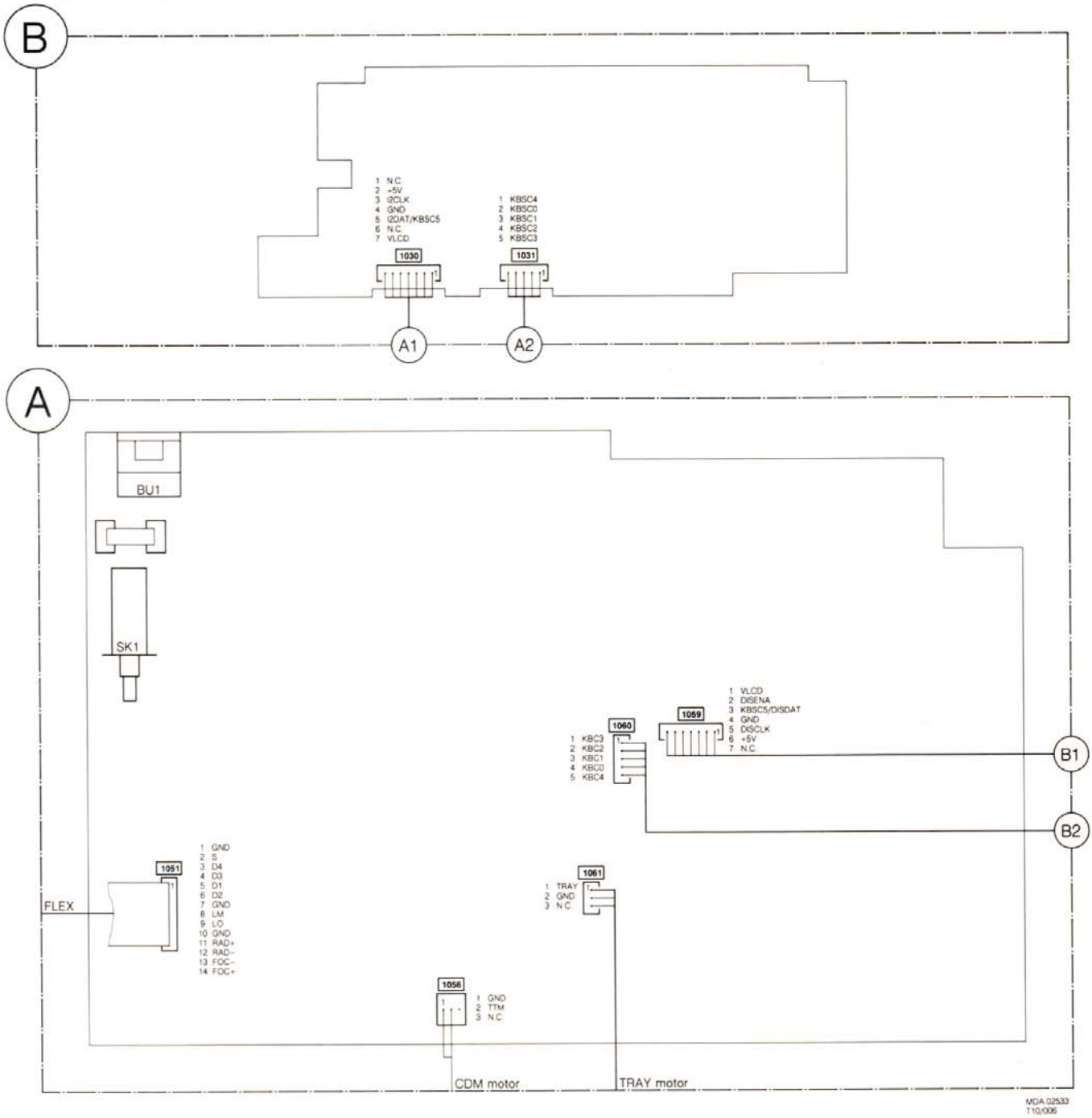
MDA 02533  
T10,006

## Miscellaneous

	4822 466 70677	Diffusor for display
	4822 265 20291	Mains inlet (BU1)
	4822 276 12907	Mains switch (SK1)
	4822 256 30274	Fuse holder
1051	4822 267 50676	Flex connector
1062	4822 276 12523	Tray tact switch (SK2)
1066	4822 267 40789	Cinch connector (BU2)
1570	4822 242 73586	Crystal 8,4672 MHz
1601	4822 242 72527	Cer. Osc. 4,0 MHz
1730	4822 070 31001	Fuse 100mA T
5730	4822 146 30861	Mains transformer



## Tools

4822 397 30184	CD audio signals
4822 397 30096	Audio test disc 5+5A
4822 397 30155	Audio test disc 1kHz
4822 397 60141	Audio disc max diam.
4822 395 50145	Torx screwdriver set
4822 395 50132	Torx screwd square
4822 395 30204	13th order filter
4822 322 40066	Service cable 14p
4822 267 50676	Service conn 14p
5322 130 32182	Led green CQYG11
4822 321 21284	Service cable 4p
4822 444 60655	Insulation cover







					
3550	4822 111 30515	18Ω 5% 0,33W	3674	4822 050 21002	1kΩ 1% 0,6W
3551	4822 111 30511	12Ω 5% 0,33W	3675	4822 050 21002	1kΩ 1% 0,6W
3552	5322 111 90091	100Ω 2% 0,25W	3680	4822 050 21002	1kΩ 1% 0,6W
3554	4822 111 90178	220Ω 2% 0,25W	3681	4822 051 10223	22kΩ 2% 0,25W
3555	4822 101 10685	4,7kΩ 20% 0,05W Trimpot Lin.	3682	4822 116 52921	4,7kΩ 1% 0,6W
3560	4822 116 52234	100kΩ 5% 0,5W	3683	4822 116 52224	470Ω 5% 0,5W
3561	4822 116 52234	100kΩ 5% 0,5W	3684	4822 050 25603	56kΩ 1% 0,6W
3562	4822 116 52234	100kΩ 5% 0,5W	3686	4822 050 21002	1kΩ 1% 0,6W
3563	4822 116 52234	100kΩ 5% 0,5W	3687	4822 050 21002	1kΩ 1% 0,6W
3564	4822 111 30517	22Ω 5% 0,33W	3700	4822 116 52857	47kΩ 1% 0,6W
3570	4822 116 53025	2,2kΩ 1% 0,6W	3701	4822 116 53084	18kΩ 1% 0,6W
3571	4822 111 30499	4,7Ω 5% 0,33W	3702	4822 116 53084	18kΩ 1% 0,6W
3572	4822 051 10223	22kΩ 2% 0,25W	3710	4822 111 90249	10kΩ 2% 0,25W
3573	4822 050 21002	1kΩ 1% 0,6W	3711	4822 111 90249	10kΩ 2% 0,25W
3574	4822 050 21204	120kΩ 1% 0,6W	3741	4822 111 30483	1Ω 5% 0,33W
3580	4822 050 21002	1kΩ 1% 0,6W	39..	4822 051 10008	Chip jumper
3581	4822 116 52511	2,2MΩ 5% 0,5W			
3583	4822 116 53025	2,2kΩ 1% 0,6W			
3585	4822 111 30499	4,7Ω 5% 0,33W	5630	4822 148 80281	
3586	4822 111 30499	4,7Ω 5% 0,33W	5660	4822 157 60363	RH035083ST-Y7
3587	4822 050 22204	220kΩ 1% 0,6W	6540	4822 130 34173	BZX55-F5V6
3590	4822 051 10223	22kΩ 2% 0,25W	6541	4822 130 34173	BZX55-F5V6
3591	4822 051 10223	22kΩ 2% 0,25W	6570	4822 130 30621	1N4148
3592	5322 111 90473	8 X 10kΩ 2%	6590	4822 130 30621	1N4148
3593	4822 051 10223	22kΩ 2% 0,25W	6680	5322 130 30684	1N4002
3601	4822 111 30499	4,7Ω 5% 0,33W	6681	5322 130 30684	1N4002
3602	4822 051 10223	22kΩ 2% 0,25W	6682	5322 130 30684	1N4002
3603	4822 116 80881	220kΩ 5% 0,1W	6683	5322 130 30684	1N4002
3604	4822 051 10223	22kΩ 2% 0,25W	6684	4822 130 34173	BZX55-F5V6
3605	4822 051 10223	22kΩ 2% 0,25W	6760	5322 130 30684	1N4002
3610	4822 050 21203	12kΩ 1% 0,6W	6761	5322 130 30684	1N4002
3611	4822 050 15602	5,6kΩ 1% 0,4W	6770	5322 130 30684	1N4002
3612	4822 050 21203	12kΩ 1% 0,6W	6771	5322 130 30684	1N4002
3613	4822 050 21203	12kΩ 1% 0,6W	7500	4822 209 73234	TDA8808T/C3
3614	4822 050 21203	12kΩ 1% 0,6W	7510	4822 209 72587	TCA0372DP2
3617	4822 111 30517	22Ω 5% 0,33W	7530	4822 209 73235	TDA8809T/C2
3630	5322 111 90113	560Ω 2% 0,25W	7550	5322 130 44349	BC635
3631	4822 050 26201	620Ω 1% 0,6W	7560	4822 209 72587	TCA0372DP2
3632	4822 116 52921	4,7kΩ 1% 0,6W	7570	4822 209 62112	M50423FP
3640	4822 111 30499	4,7Ω 5% 0,33W	7575	4822 209 70422	MN4264-15
3641	4822 050 22702	2,7kΩ 1% 0,6W	7590	4822 209 62367	MC68HC05C8P/9441
3650	4822 051 10223	22kΩ 2% 0,25W	7630	4822 130 61207	BC848
3651	4822 116 52921	4,7kΩ 1% 0,6W	7640	4822 209 73236	TDA1543/N2
3652	4822 051 10223	22kΩ 2% 0,25W	7650	4822 130 61207	BC848
3653	4822 111 90249	10kΩ 2% 0,25W	7651	5322 130 42012	BC858
3654	4822 050 21002	1kΩ 1% 0,6W	7652	4822 130 61207	BC848
3655	4822 050 21002	1kΩ 1% 0,6W	7653	4822 130 61207	BC848
3656	4822 050 25601	560Ω 1% 0,6W	7660	4822 209 83163	LM833N
3657	4822 050 25601	560Ω 1% 0,6W	7661	4822 209 83163	LM833N
3658	4822 116 52528	4,7MΩ 5% 0,5W	7680	5322 130 42012	BC858
3659	4822 116 52528	4,7MΩ 5% 0,5W	7682	4822 130 44121	BC338
3660	4822 116 52918	2,7kΩ 1% 0,6W	7683	4822 130 44121	BC338
3661	4822 050 22702	2,7kΩ 1% 0,6W	7700	4822 130 61207	BC848
3662	4822 051 20122	1,2kΩ 5% 0,1W	7710	5322 130 42012	BC858
3663	4822 051 20122	1,2kΩ 5% 0,1W	7760	4822 209 71579	TY40408
3664	4822 051 10122	1,2kΩ 2% 0,25W	7770	4822 209 73233	MC79L05ACP
3665	4822 051 10122	1,2kΩ 2% 0,25W			
3666	4822 050 12402	2,4kΩ 1% 0,4W			
3667	4822 050 12402	2,4kΩ 1% 0,4W			
3668	4822 051 20122	1,2kΩ 5% 0,1W			
3669	4822 051 20122	1,2kΩ 5% 0,1W			
3670	4822 111 30517	22Ω 5% 0,33W			
3671	4822 111 30517	22Ω 5% 0,33W			
3672	4822 051 10223	22kΩ 2% 0,25W			
3673	4822 051 10223	22kΩ 2% 0,25W			



**MODIFICATIONS WITH A90-117**

<b>Page</b>	<b>Reason</b>
Frontpage	/10G/40B/45B/ added
2-3a	Partslist updated
6-1	Modifications added