

# SERVICE MANUAL

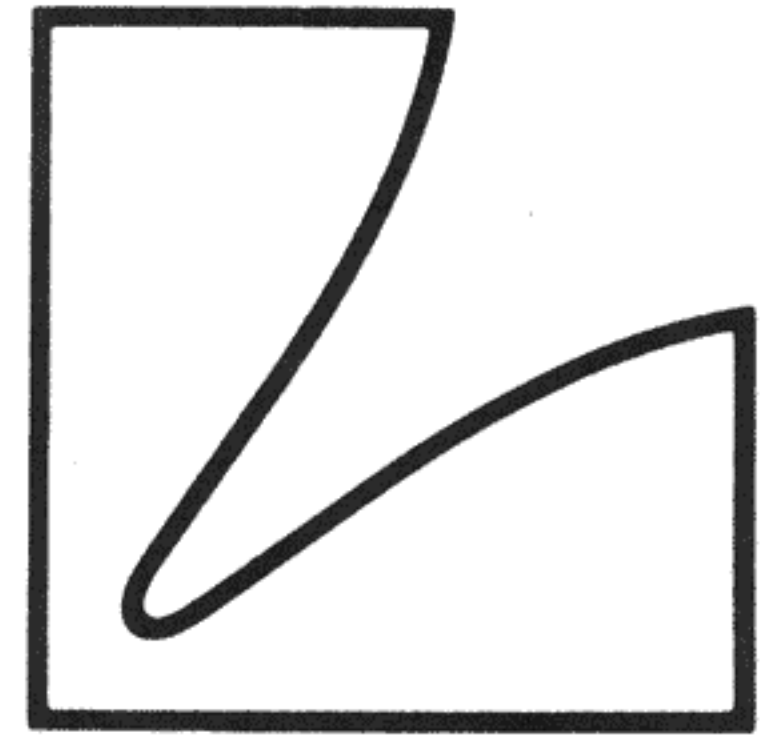

## STEREO POWER AMPLIFIER M120A



# BLOCK DIAGRAMME

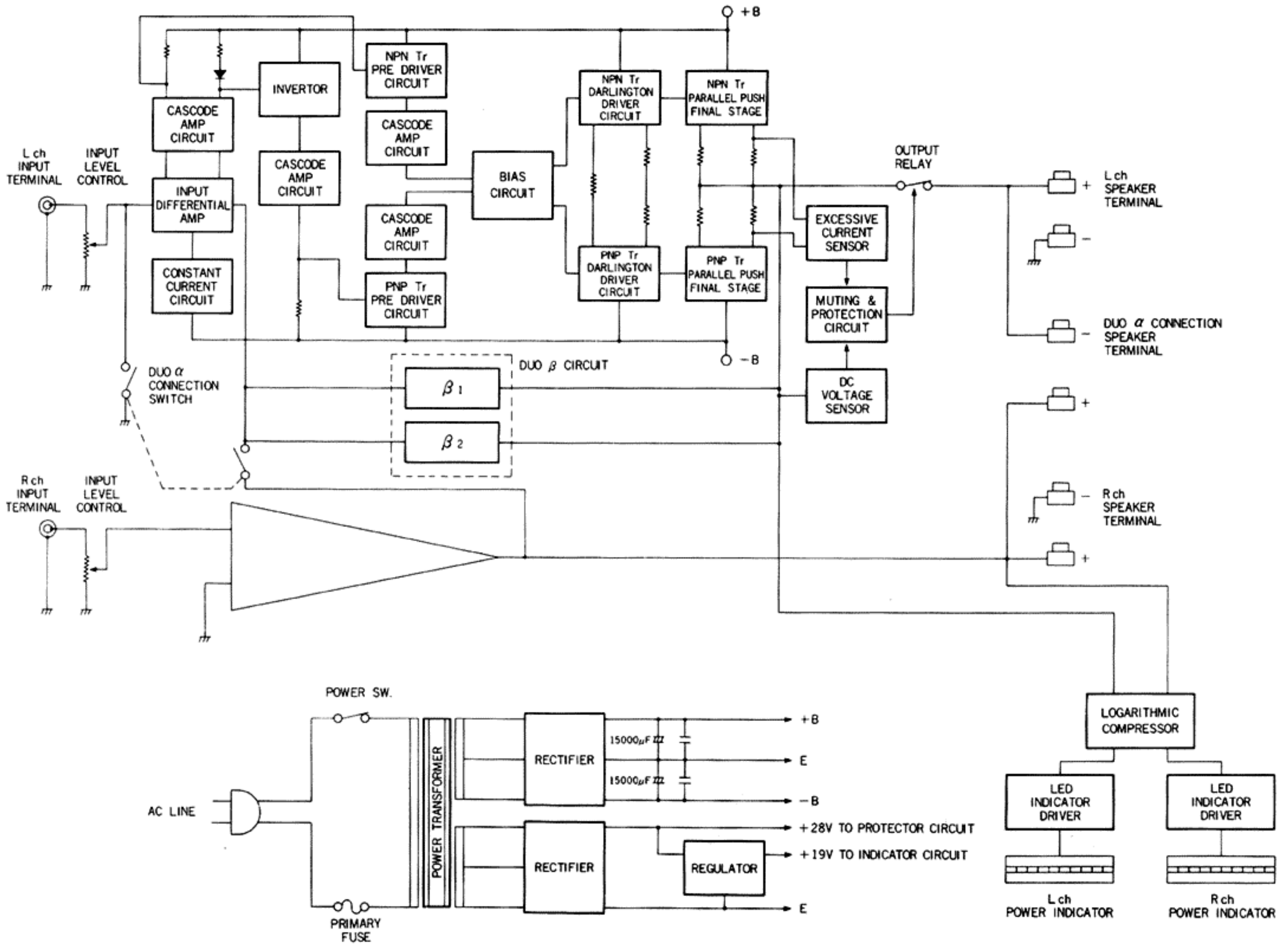

## SPECIFICATIONS

<b>Power Output:</b>	120 watts minimum continuous per channel, both channels driven into 8 ohms load, at any frequency from 20Hz to 20,000Hz with no more than 0.015% total harmonic distortion.
<b>Duo-Alpha Connection Output:</b>	300 watts into 8 ohms load with no more than 0.03% total harmonic distortion.
<b>Rated I.M.:</b>	no more than 0.01% (8 ohms, 120W/ch, 60Hz : 7kHz = 4 : 1)
<b>Input Sensitivity:</b>	900 mV
<b>Input Impedance:</b>	160K ohms
<b>Signal-to-Noise Ratio:</b>	better than 110 dB (IHF-A weighted, input short-circuited)
<b>Frequency Response:</b>	10 Hz – 100,000Hz (within -1 dB)
<b>Damping Factor:</b>	50
<b>Additional Features:</b>	Power Indicator, Power Indicator Sensitivity Selector (full, off, 1/100), Speaker Selector, Input Level Set, Headphone Jack, Selector for Duo-Alpha Connection.
<b>Power Consumption:</b>	120V 5A 480W (120W, 8 ohms load)
<b>Dimensions:</b>	464(W) x 336(D) x 176(H) mm wooden case (18-1/4" x 13-7/32" x 6-15/16") 438(W) x 336(D) x 141(H) mm metal cabinet (17-1/4" x 13-7/32" x 5-9/16")
<b>Weight:</b>	Net 13.8 kgs (30.4 lbs.) wooden case Gross 15.3 kgs (33.7 lbs.) Net 14.2 kgs (31.2 lbs.) metal cabinet Gross 15.7 kgs (34.5 lbs.)

Specifications and appearance design subject to change without notice.

## ALIGNMENT PROCEDURE

### (1) Set up the Amplifier

Input Level Vol.	Minimum
Speaker Sel.	Main Position
Power indicator	Off
DUO-ALPHA Sel.	Normal

### (2) Turn on the Power Switch and wait 3 minutes for warm up.

## DC offset Adjustment

### (1) Connect DC Voltmeter at Main Speaker terminal.

### (2) Adjust on PD5115-1

VR 134a - Left Channel  
VR 134b - Right Channel

to get 0 (Zero) Volt in DC Voltmeter.

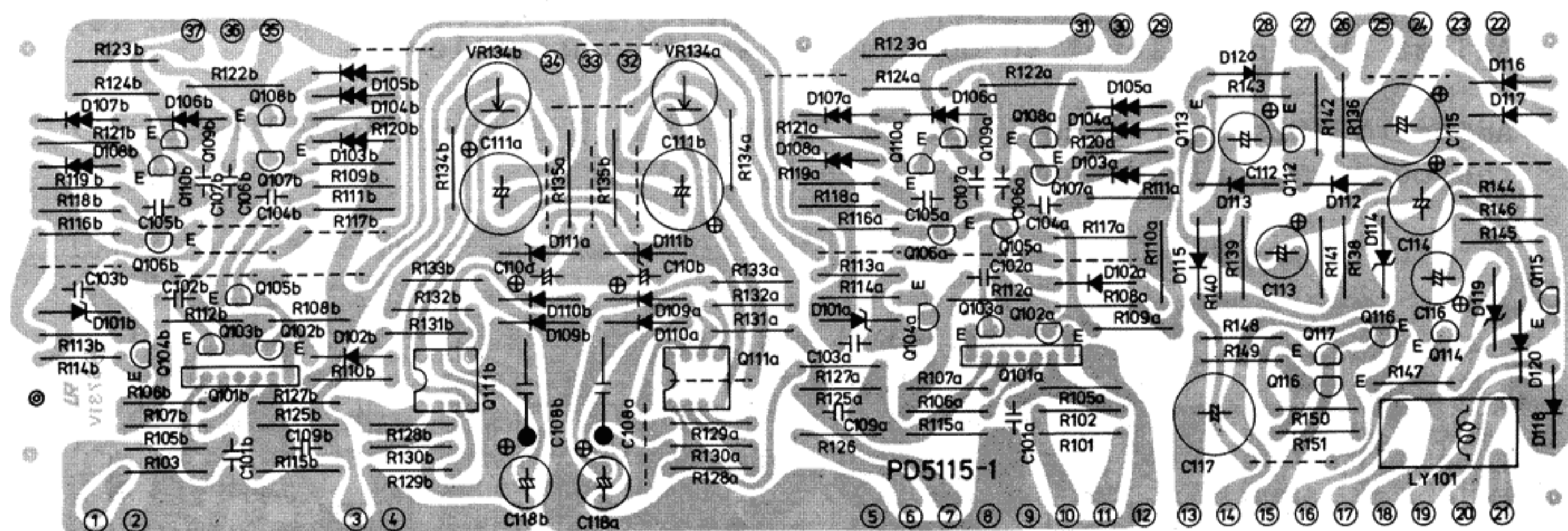

< Fig.-1 >

## Bias (Idle current) Adjustment

< Lett Channel >

### (1) Take off Fuse, F805 on PB5115-8.

### (2) Connect DC Ammeter between Pin No.8(+) and Pin No.13(-) on PD5115-8.

### (3) Adjust VR 201a to get 70 mA in DC Ammeter.

< Right Channel >

- (1) Take off Fuse, F801 on PB5115-8.
- (2) Connect DC Ammeter between Pin No.4(+) and Pin No.16(-) on PD5115-8.
- (3) Adjust VR 201b to get 70 mA in DC Ammeter.

Over load protection threshold Level Adjustment.

< Connection method of test equipment >

Oscilloscope  
AC Voltage meter ] ----- Connect to main Speaker terminal.

Audio Signal Generator ----- Input terminal.

- (1) Connect load (4 Ohm 180W) at main speaker terminal.
- (2) Put 1 KHz sine wave into the left (Right) channel input with the level control at maximum
- (3) Adjust the input level to obtain 26V at the output level.
- (4) Adjust VR202a/left chan. (VR202b)/Right Chan.) on the PD115-2 so that the output should disappear. (See Fig. 2)

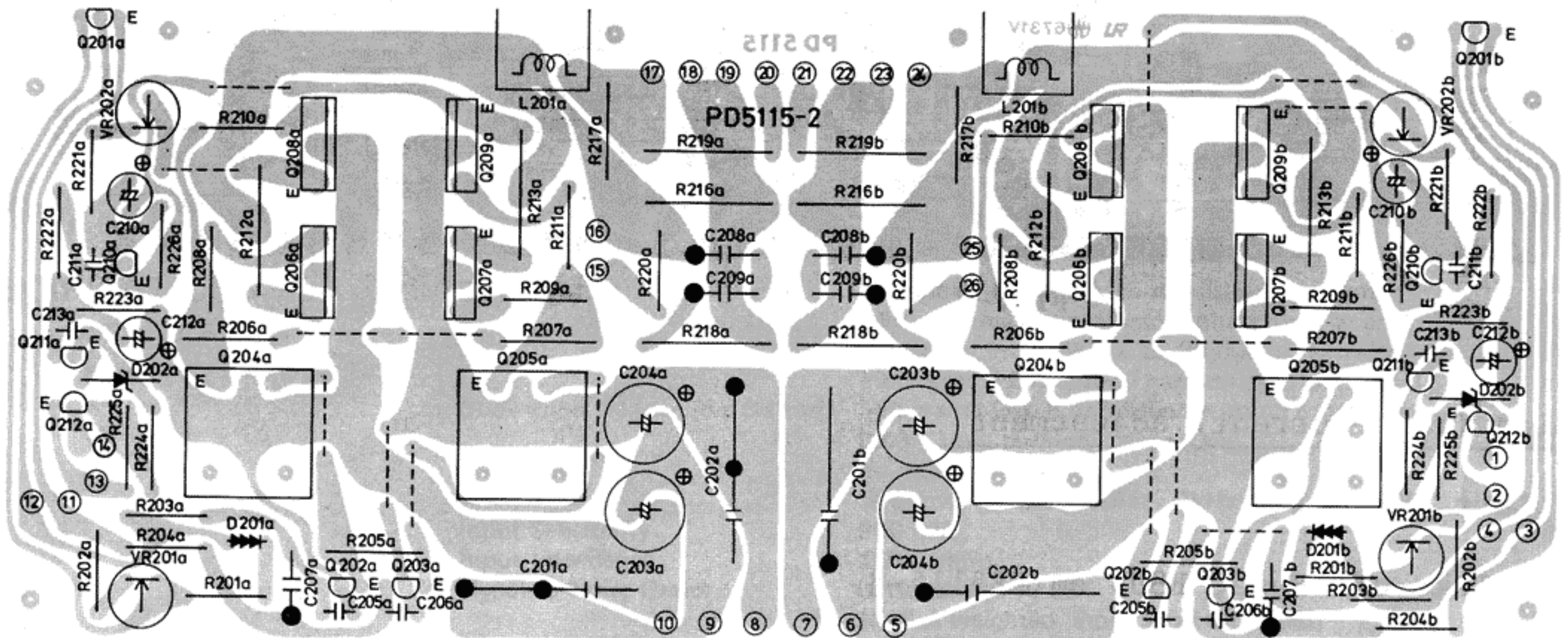

< Fig.- 2 >

## Power Indicators Level Adjustment .

Don't Connect any load to the Speaker terminal.

- (1) Set up the power indicator switch to "1/100" position.
- (2) Adjust the input level to get 3V at the output level.
- (3) Adjust the VR401 (VR302) on the PD5115-4 (PD5115-3) to light up the 120 W LED indicator.
- (4) Set up the power indicator switch to full position
- (5) Adjust the input level to get 30V at the output.
- (6) Adjust the VR301a (VR301b) on the PD5115-3 to light up the 120W LED indicator.
- (7) Repeat the step (1) — (6). (2 - 3 times)
- (8) Set up the power indicator switch to "1/100" position.
- (9) Adjust the input level to light up the 0.25W LED indicator of right channel.
- (10) Adjust the VR402 on the PD5115-4 to light up to 0.25W LED indicator of left channel.
- (11) Adjust the input level to get 3V at the output.
- (12) Adjust the VR401 on the PD5115-4 to light up the 120W LED indicator of left channel.
- (13) Repeat the Step (8) — (12). (2 - 3 times)

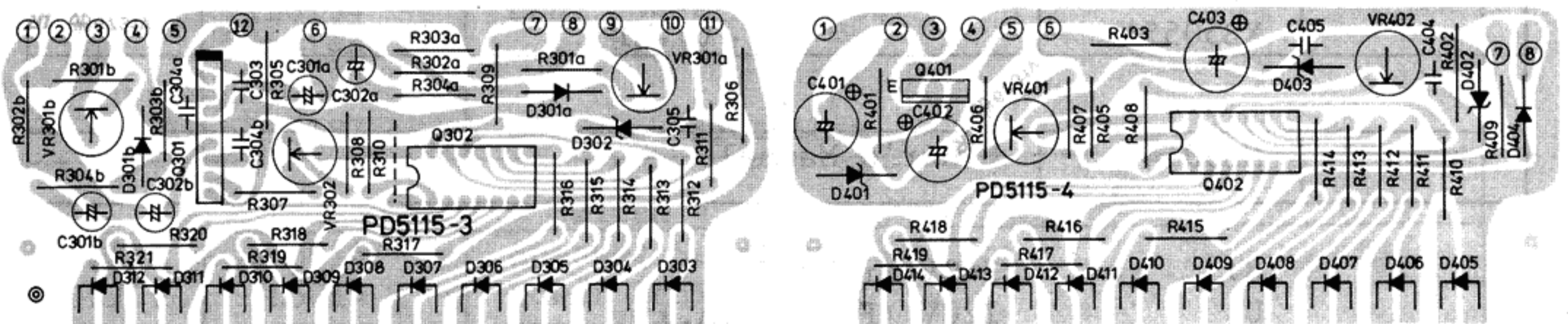

< Fig.- 3 >

# REPLACEMENT PARTS (Cosmetic)

## FRONT VIEW

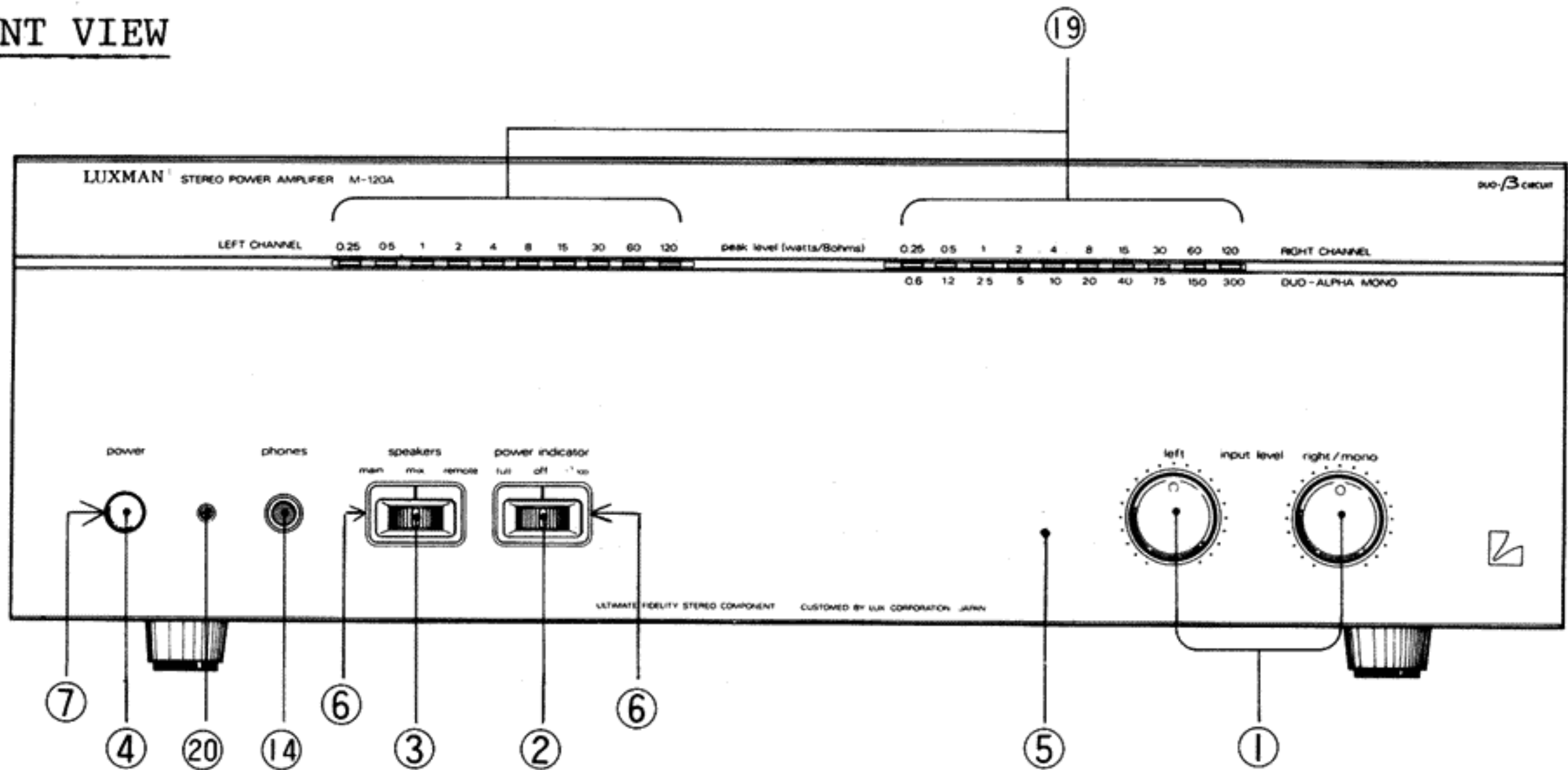

## REAR VIEW

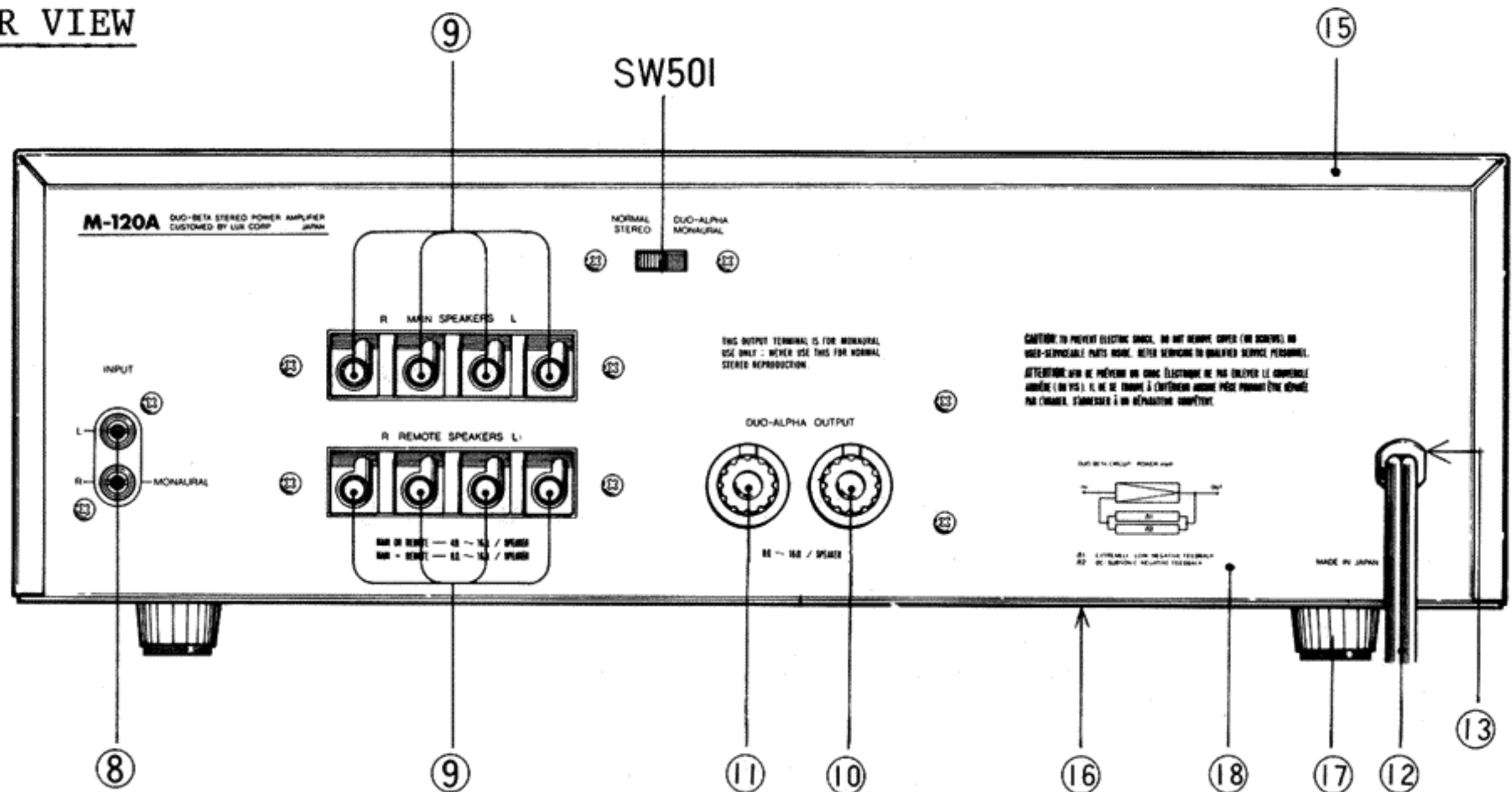

## Parts List

REF.NO.	STOCK NO.	DESCRIPTION
< Packing Material >		
	XA5101B	Carton (E,S)
	XA5101A	(U,C)
	XB5055B	Pad (E,S)
	XB5055A	(U,C)
	ME5014	Owner's Manual

S: 240V or 220V  
 U: 120V (For U.S.A.)  
 C: 120V (For Canada)  
 E: 220V (With Line Voltage Selector)

Parts List (Cosmetic)

REF.NO.	STOCK NO.	DESCRIPTION
< Knob >		
1	WH5009	Input Level, Left, Right (E,S)
	WK5040A	(U,C)
2	WJ3009	Power IND. (E,S)
	WJ1121	(U,C)
3	WJ3009	Speaker (E,S)
	WJ1121	(U,C)
4	WJ1133	Power Switch
< Front Panel >		
5	WA5058A	Front Panel
6	WD1122M	Escutcheon (Lever SW.)
	WD5016	(Power ind. LED)
7	WE1089	Protector (Power SW.)
< Terminal >		
8	AT5025	Input
9	AT0080	Speaker, Main Remote
10	AT5026B	Speaker, Duo alpha (Red)
11	AT5026A	(Black)
< Power Cord >		
12	BK0022	240V or 220V (S)
	BK0019	120V (U)
	BK0027	120V (C)
	BK0019	100 ~ 240V (E)
< Bushing, Power Cord >		
13	BU0039	For Power Cord BK0019, 27
	BU0033	For Power Cord BK0022
14	AJ0016	Phone Jack
15	UG5022	Bonnet (E,S)
15'	WB5004	Wooden Case (U,C)
	WT1029	Ventilator (U,C)
16	UE5021	Bottom Plate (E,S)
17	WN007	Foot (E,S)
	WN1019	(U,C)
18	UC5026	Rear Panel (E,S,U)
	UC5034	(C)
19	TD0134	LED, Power Indicator
20	TD0196	Pilot Lamp
	AS0187	Socket, Pilot Lamp
< Switch >		
SW601	SL5014	Speaker Selector
SW701	SL5014	Power Indicator
SW501	SS5023	DUO Alpha-Normal
SW01	SP0090	Power (E,S)
	SP0063	(U,C)
< Variable Resistor >		
VR01ab		Input Level

REPLACEMENT PARTS LIST -----(P.C.B.)

1. Resistors	<p>±5% 1/3 Watt deposite carbon Resistors unless noted otherwise.</p> <p>C.: Carbon Resistor. F.P.C.: Flameproof Carbon Resistor. F.P.M.: Flameproof Metal Film Resistor. F.P.O.: Flameproof Metal Oxide Film Resistor. F.P.M.F.: Flameproof Metal Film Fuseble Resistor. F.P.O.F.: Flameproof Metal Oxide Film Fuseble Resistor. M.: Metal Film Resistor. O.: Metal Oxide Film Resistor. C.M.:</p>
2. Capasitors	<p>M.Y.: Mylcar film Capacitor Uylar = polyester. M.M.: Metallized Mylar film Capacitor M.C.: Mica Capacitor P.: Polystyrene Film Capacitor C.: Ceramic Capacitor. E.: Electrolytic Capacitor. B.P.: Bi Polarized Electrolytic Capacitor. M.P.: Metallized Paper Film Capacitor.</p>
3. !	<p>This Simbol is used to indicate that a specific component must be replaced only by the component specified in that documentation for safety reasons.</p>



PD5115-1 Resistors

Symbol No.	Parts No.	Description & Specification
R101	RD0474	220Ω
R102	RD0474	220Ω
R103	RD0470	470Ω
R104		None
R105 a,b	RD0430	1MΩ
R106 a,b	RD0489	10Ω
R107 a,b	RD0489	10Ω
R108 a,b	RD0444	68KΩ
R109 a,b	RD0466	1KΩ
R110 a,b	RD0466	1KΩ
R111 a,b	RD0478	100Ω
R112 a,b	RD0454	10KΩ
R113 a,b	RD0448	33KΩ
R114 a,b	RD0466	1KΩ
R115 a,b	RD0468	680Ω
R116 a,b	RD0478	100Ω
R117 a,b	RD0466	1KΩ
R118 a,b	RD0466	1KΩ
R119 a,b	RD0478	100Ω
R120 a,b	RD0480	68Ω
R121 a,b	RD0480	68Ω
R122 a,b	! RS5033	39KΩ ±5% 1W F.P.O.
R123 a,b	{ RD2640	270KΩ ±5% 1/2W C
	{ RD2654	1MΩ ±5% 1/2W C
R124 a,b	{ RD2640	270K ±5% 1/2W C
	{ RD2654	1MΩ ±5% 1/2W C
R125 a,b	RD0450	22KΩ
R126	RD0450	22KΩ
R127 a,b	{ RD0450	22KΩ
	{ RD0451	18KΩ
R128 a,b	RD0454	10KΩ
R129 a,b	RD0457	5.6KΩ
R130 a,b	RD0454	10KΩ
R131 a,b	{ RD2139	240KΩ
	{ RD0434	470KΩ
R132 a,b	{ RD2139	240KΩ
	{ RD0434	470KΩ
R133 a,b	RD0478	100Ω
R134 a,b	RD0454	10KΩ
R135 a,b	! RS5060	3.9KΩ ±5% 1W F.P.O
R136	RD2594	3.3KΩ ±5% 1/2W C
R137		None
R138	RD0446	47KΩ
R139	RD0460	3.3KΩ
R140	RD0446	47KΩ
R141	RD0442	100KΩ
R142	RD0430	1MΩ
R143	RD0430	1MΩ
R144	RD0458	4.7KΩ
R145	RD0454	10KΩ
R146	RD0434	470KΩ
R147	RD0475	180Ω
R148	RD0446	47KΩ
R149	RD0455	8.2KΩ
R150	RD0450	22KΩ
R151	RD0458	4.7KΩ

PD5115-1 Capacitors

Symbol No.	Parts No.	Description & Specification
C101 a,b		None
C102 a,b	CQ0007	0.068 $\mu$ F $\pm$ 10% 50V MY
C103 a,b	CK0158	0.047 $\mu$ F C
C104 a,b	CQ0319	3300pF $\pm$ 5% 50V P
C105 a,b	CQ0319	3300pF $\pm$ 5% 50V P
C106 a,b	CM0164	5pF 500V MC
C107 a,b	CM0164	5pF 500V MC
C108 a,b	{ CQ0953	1 $\mu$ F $\pm$ 10% 100V MM
	{ CQ2010	2.2 $\mu$ F $\pm$ 10% 125V MM
C109 a,b	CM0135	7pF 50V MC
C110 a,b	CE1729	22 $\mu$ F 25V E
C111 a,b	CE1781	100 $\mu$ F 100V E
C112	CE1739	10 $\mu$ F 35V E
C113	CE1739	10 $\mu$ F 35V E
C114		None
C115	CE1743	100 $\mu$ F 35V E
C116	CE1740	22 $\mu$ F 35V E
C117	CE0937	100 $\mu$ F 25V B.P.
C118 a,b		None
C119 a,b	CQ0079	470pF $\pm$ 5% 50V P S56.1~
	CQ0968	0.47 $\mu$ F $\pm$ 10% 100V MM
	CQ2006	0.47 $\mu$ F $\pm$ 10% 125V MM S56.1~
	CQ2006	0.47 $\mu$ F $\pm$ 10% 125V MM
	CQ0079	470pF $\pm$ 5% 50V P ADD. for C110 a,b
	CQ0060	470pF $\pm$ 5% 125V P ADD. for C119 a,b

PD5115-1 Transistors, Diodes

SYMBOL NO.	Parts No.	Description & Specification
Q101 a,b	TF5004	2SK150 GR
Q102 a,b	TR5004	2SC2240 BL
Q103 a,b	TR5004	2SC2240 BL
Q104 a,b	TR5004	2SC2240 BL
Q105 a,b	TR5005	2SA970 BL
Q106 a,b	TR5005	2SA970 BL
Q107 a,b	TR5005	2SA970 BL
Q108 a,b	TR0237	2SA949 O.Y
Q109 a,b	TR0236	2SC2229 O.Y
Q110 a,b	TR5004	2SC2240 BL
Q111 a,b	TC5002	NJM4558D
Q112	TR0198	2SC1815 Y
Q113	TR0198	2SC1815 Y
Q114	TR0264	2SC2235 O.Y
Q115	TR0198	2SC1815 Y
Q116	TR0087	2SA1015 Y
Q117	TR0198	2SC1815 Y
Q118	TR0198	2SC1815 Y
D101 a,b	TD0043	WZ061
D102 a,b	TD0132	1S2472
D103 a,b	TV0030	KB-265-C4
D104 a,b	TV0030	KB-265-C4
D105 a,b	TV0030	KB-265-C4

D106 a,b	TV0030	KB-265-C4
D107 a,b	TV0030	KB-265-C4
D108 a,b	TV0030	KB-265-C4
D109 a,b	TD0132	1S2472
D110 a,b	TD0132	1S2472
D111 a,b	TD0109	WZ-150
D112	TD0132	1S2472
D113	TD0132	1S2472
D114		None
D115	TD0018	1K-188FM
D116	TD002	1N4002
D117	TD0002	1N4002
D118	TD0002	1N4002
D119	TD0109	WZ-150
D120	TD0132	1S2472
D121	TD0132	1S2472

PD5115-1

SYMBOL NO.	Parts No.	Description & Specification
LY101	AY0047	BR221D024P
VR134 a,b	RT0010	47KΩ (B)

PD5115-1

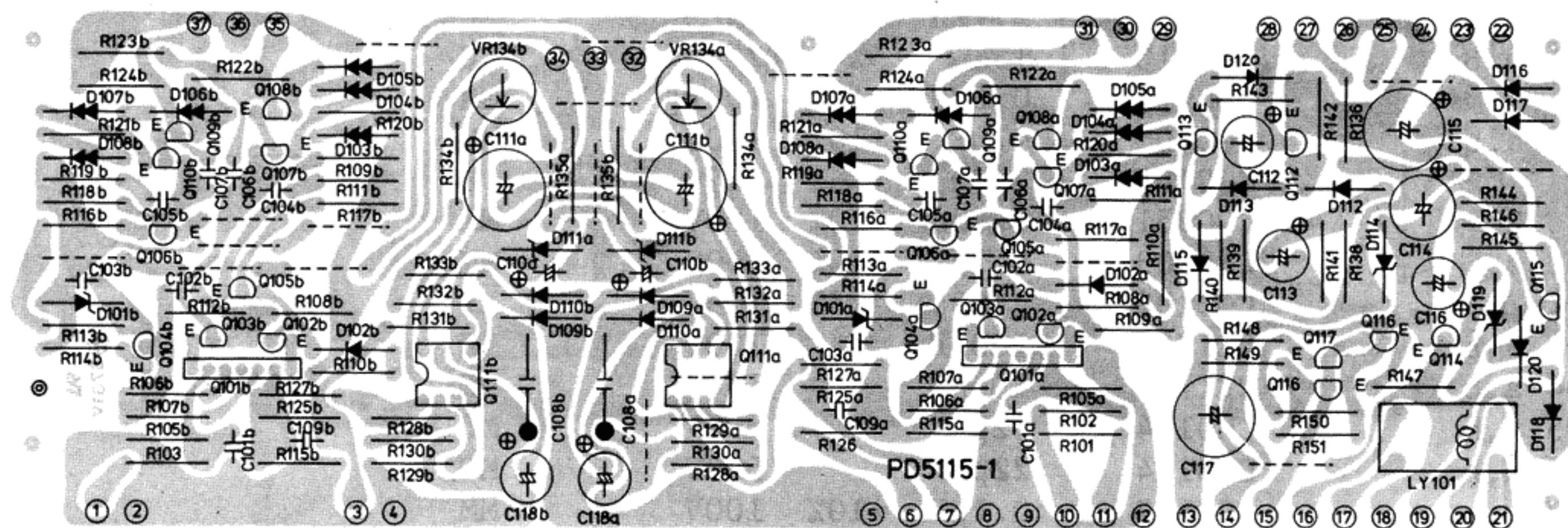

PD5115-2 Resistor

Symbol No.	Parts No.	Description & Specification	
R201 a,b	RD0468	680Ω	
R202 a,b	RD0474	220Ω	
R203 a,b	! RS5049	56Ω ±5% 1/3W	F.P.C
R204 a,b	! RS5049	56Ω ±5% 1/3W	F.P.C
R205 a,b	! RS5059	470Ω ±5% 1W	F.P.O
R206 a,b	! RS0117	100Ω ±5% 1W	F.P.O
R207 a,b	! RS0117	100Ω ±5% 1W	F.P.O
R208 a,b	! RS5051	10Ω ±5% 1/2W	F.P.C
R209 a,b	! RS5051	10Ω ±5% 1/2W	F.P.C
R210 a,b	! RS5051	10Ω ±5% 1/2W	F.P.C
R211 a,b	! RS5051	10Ω ±5% 1/2W	F.P.C
R212 a,b	! RG0600	0.22Ω ±10% 5W x 2	
R213 a,b	! RG0600	0.22Ω ±10% 5W x 2	
R214		None	
R215		None	
R216 a,b	! RS0119	1KΩ ±5% 2W	F.P.O
R217 a,b	! RS0117	10Ω ±5% 1W	F.P.M
R218 a,b	! RS5004	10Ω ±5% 2W	F.P.M
R219 a,b	! RS5007	100Ω ±5% 2W	F.P.O
R220 a,b	RD0448	33KΩ	
	RD2584	1.2KΩ ±5% 1/2W	C
R221 a,b	! RS5072	"	F.P.C
	!	"	F.P.O.F
R222 a,b	RD2608	12KΩ ±5% 1/2W	C
R223 a,b	RD2608	12KΩ ±5% 1/2W	C
R224 a,b	RD2616	27KΩ ±5% 1/2W	C
R225 a,b	RD2592	2.7KΩ ±5% 1/2W	C
R226 a,b	RD261D	15KΩ ±5% 1/2W	C
	CQ0951	0.68μF ±10% 100V	MM
C201 a,b	CQ0603	47μF ±10% 100V	MM
	CQ0195	2400pF ±5% 125V	P
	CQ0951	0.68μF ±10% 100V	MM
C202 a,b	CQ0603	4.7μF ±10% 100V	MM
	CQ0195	2400pF ±5% 125V	P
C203 a,b	CE1781	100μF 100V	E
C204 a,b	CE1781	100μF 100V	E
C205 a,b	CM0114	22pF 500V	MC
C206 a,b	CM0114	22pF 500V	MC
	CQ0613	0.1μF ±10% 100V	MM
C207 a,b	CQ0952	"	
	CQ0079	470pF ±5% 50V	P
	CQ0612	0.15μF ±10% 100V	MM
C208 a,b	CQ0968	"	"
	CQ0692	0.15±μF "	"
	CQ0613	0.15μF ±10% 100V	MM
C209 a,b	CQ0968	"	
	CQ0692	"	
C210 a,b	CE1718	22μF 16V	E
C211 a,b	CC0126	330pF 500V	C
C212 a,b	CE1776	4.7μF 100V	E
C213 a,b	CC0126	330pF 500V	C

PD5115-2 Transistor Diode

Symbol No.	Parts No.	Description & Specification	
Q201 a,b	TR0198	2SC1815	Y
Q202 a,b	TR0236	2SC2229	O.Y
Q203 a,b	TR0237	2SA949	O.Y
Q204 a,b	TR0209	2SC2238	O.Y
Q205 a,b	TR0210	2SA968	O.Y
Q206 a,b	TR0295	2SC2581	
Q207 a,b	TR0294	2SA1106	
Q208 a,b	TR0295	2SC2581	
Q209 a,b	TR0294	2SA1106	
Q210 a,b	TR5004	2SC2240	BL
Q211 a,b	TR5005	2SA970	BL
Q212 a,b	TR5004	2SC2240	BL
D201 a,b	TV0020	STV-3H	
D202 a,b	TD0060	WZ-061	
VR201 a,b	RT0007	470Ω (B)	
VR202 a,b	RT0032	3.3KΩ (B)	
L201 a,b	LA1020	Coil 1020	

PD5115-2

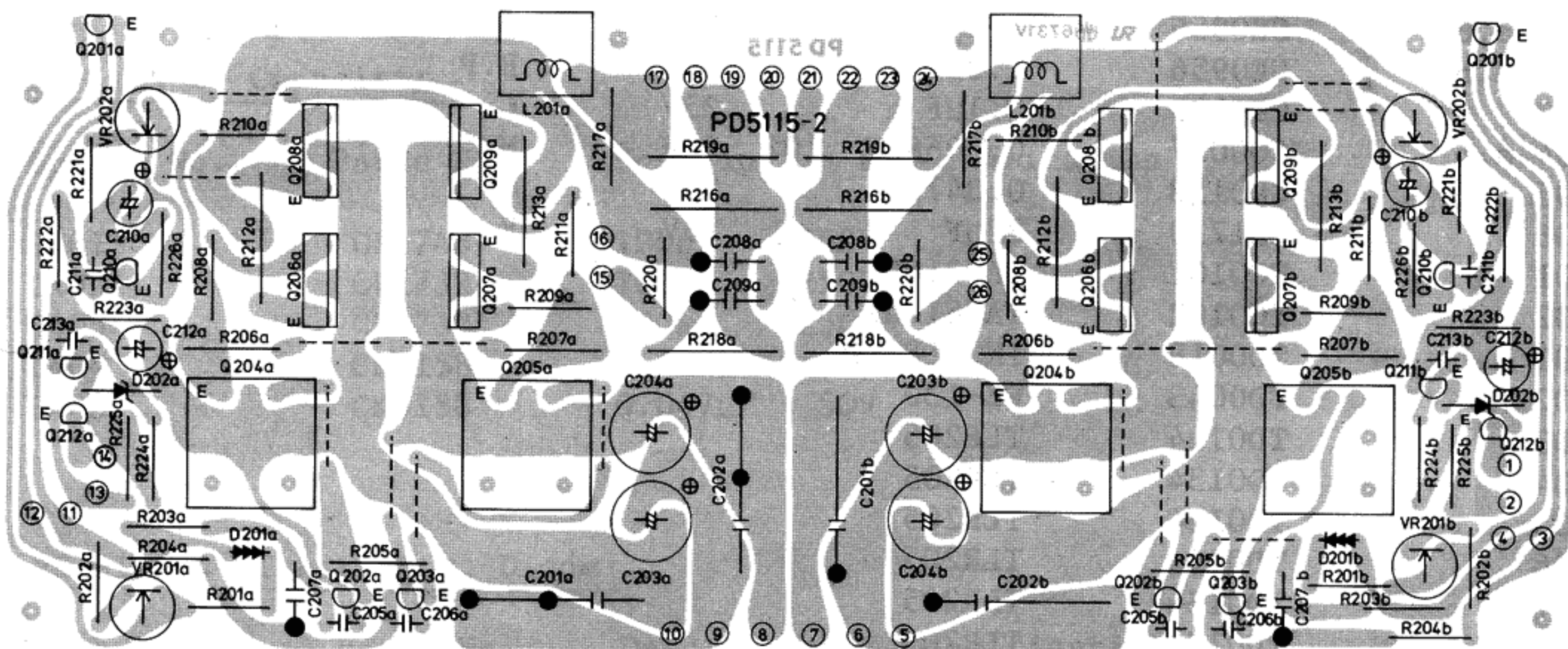

PD-5115-3 Resistor

Symbol No.	Parts No.	Description & Specification
R301 a,b	RD0451	18K $\Omega$
R302 a,b	RD0464	1.5K $\Omega$
R303 a,b	RD0456	6.8K $\Omega$
R304 a,b	RD0456	6.8K $\Omega$
R305	RS5056	180 $\Omega$ $\pm$ 5% 1W F.P.O
R306	RS5059	470 $\Omega$ $\pm$ 5% 1W F.P.O
R307	RD0470	470 $\Omega$
R308	RD0470	470 $\Omega$
R309	RD0470	12K $\Omega$
R310	RD0455	8.2K $\Omega$
R311	RD0452	15K $\Omega$
R312	RD0462	2.2K $\Omega$
R313	RD0462	2.2K $\Omega$
R314	RD0462	2.2K $\Omega$
R315	RD0462	2.2K $\Omega$
R316	RD0462	2.2K $\Omega$
R317	RD0462	2.2K $\Omega$
R318	RD0462	2.2K $\Omega$
R319	RD0462	2.2K $\Omega$
R320	RD0462	2.2K $\Omega$
R321	RD0462	2.2K $\Omega$
C301 a,b	CE0956	2.2 $\mu$ F 50V B.P
C302 a,b	CE0956	2.2 $\mu$ F 50V B.P
C303	CK0159	0.1 $\mu$ F 25V C
C304 a,b	CQ0027	0.0068 $\mu$ F 10% 50V MY
C305	CK0158	0.047 $\mu$ F 50V C
C306	CE1729	22 $\mu$ F 25V E
Q301	TC0101	TA7318P
Q302	TC0102	TA7612AP
D301 a,b	TD0018	1K $\Omega$ 188FM
D302	TD0043	WZ-130
D303	TD0134	TLR205
D304	TD0134	TLR205
D305	TD0134	TLR205
D306	TD0134	TLR205
D307	TD0134	TLR205
D308	TD0134	TLR205
D309	TD0134	TLR205
D310	TD0134	TLR205
D311	TD0134	TLR205
D313	TD0134	TLR205
VR301 a,b	TD0063	22K $\Omega$ (B)
VR302	RT0008	1K $\Omega$ (B)

PD5115-3

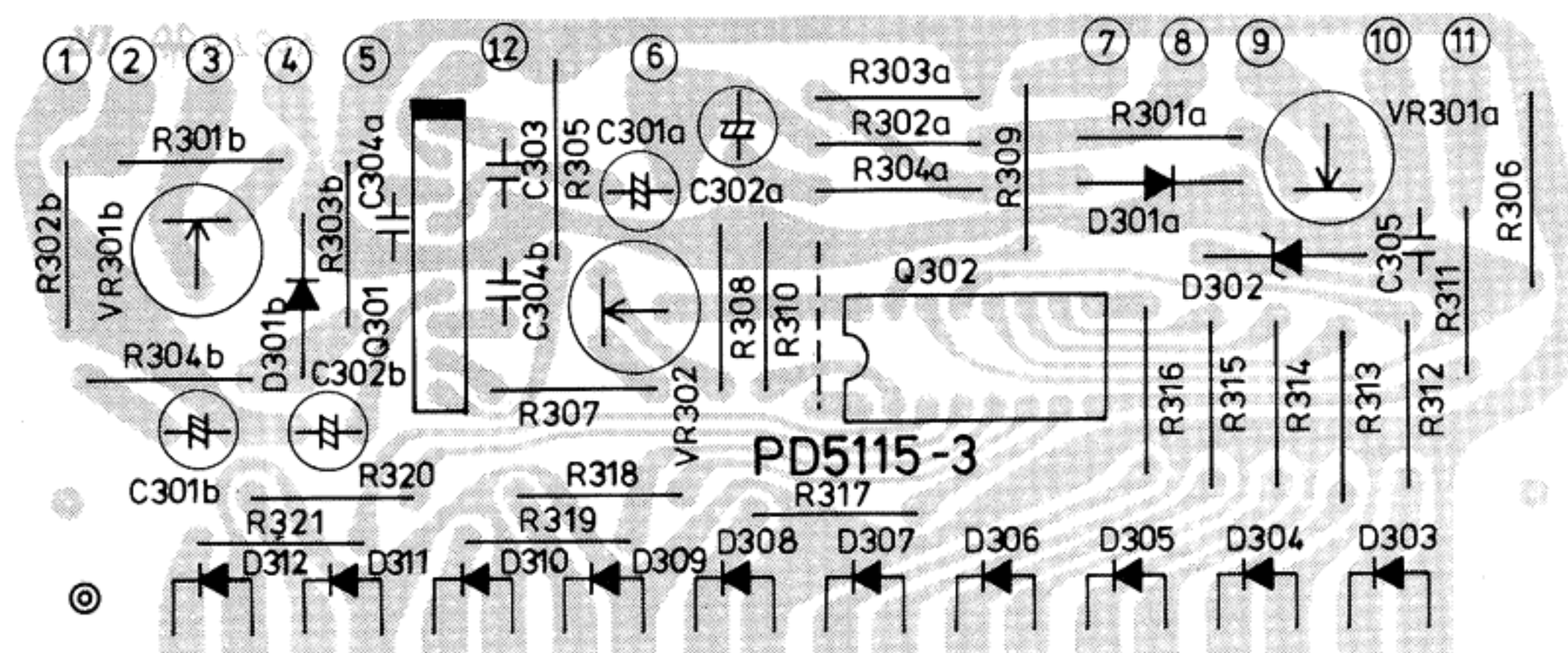

PD-5115-4 Resistor

Symbol No.	Parts No.	Description & Specification
R401	RD2592	2.7K $\Omega$ $\pm$ 5% 1/2W C
R402	! RS5059	470 $\Omega$ $\pm$ 5% 1W F.P.O
R403	RD0458	4.7K $\Omega$
R404		None
R405	RD0453	12K $\Omega$
R406	RD0470	470 $\Omega$
R407	RD0470	470 $\Omega$
R408	RD0456	6.8K $\Omega$
R409	RD0452	15K $\Omega$
R410	RD0462	2.2K $\Omega$
R411	RD0462	2.2K $\Omega$
R412	RD0462	2.2K $\Omega$
R413	RD0462	2.2K $\Omega$
R414	RD0462	2.2K $\Omega$
R415	RD0462	2.2K $\Omega$
R416	RD0462	2.2K $\Omega$
R417	RD0462	2.2K $\Omega$
R418	RD0462	2.2K $\Omega$
R419	RD0462	2.2K $\Omega$

PD-5115-4 Capacitor

Symbol No.	Parts No.	Description & Specification
C401	CE1743	100 $\mu$ F 350V E
C402	CE1732	100 $\mu$ F 250V E
C403	CE1732	100 $\mu$ F 250V E
C404	CK0158	0.047 $\mu$ F 50V C
C405	CK0158	0.047 $\mu$ F 50V C

PD-5115-4 Transistor, Diode

Symbol No.	Parts No.	Description & Specification
Q401	TR5012	2SD880
Q402	TC0102	TA7612AP
D401	TD0065	WZ-192
D402	TD0043	WZ-130
D403	TD0060	WZ-061
D404	TD0002	1N4002
D405	TD0134	TLR205
D406	TD0134	TLR205
D407	TD0134	TLR205
D408	TD0134	TLR205
D409	TD0134	TLR205
D410	TD0134	TLR205
D411	TD0134	TLR205
D412	TD0134	TLR205
D413	TD0134	TLR206
D414	TD0134	TLR205

PD-5115-4

Symbol No.	Parts No.	Description & Specification
VR401	RT0008	1KΩ (B)
VR402	RT0025	4.7KΩ (B)

PD5115-4

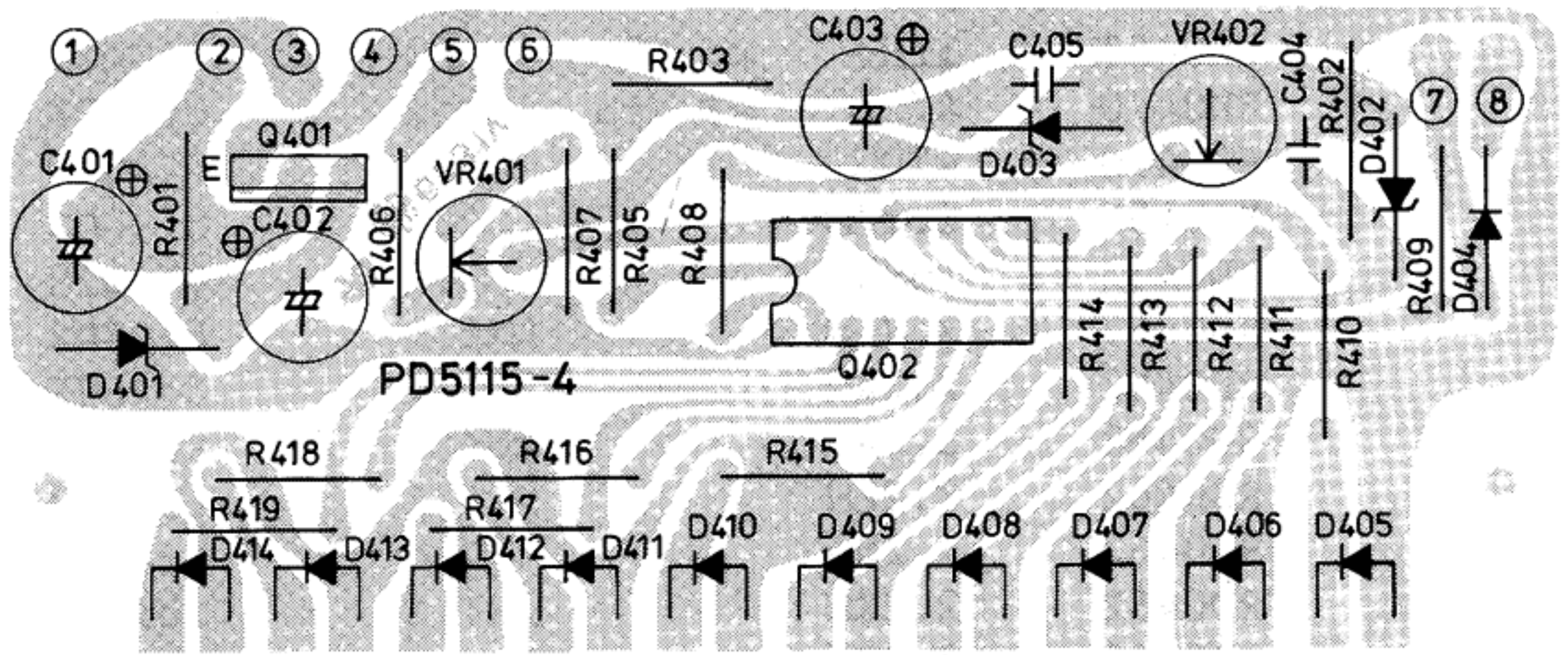

PD-5115-5

Symbol No.	Parts No.	Description & Specification
R501	RD0442	100KΩ
R502	RD0463	1.8KΩ
SW501	SL5014	SLR523 NS

PD5115-5

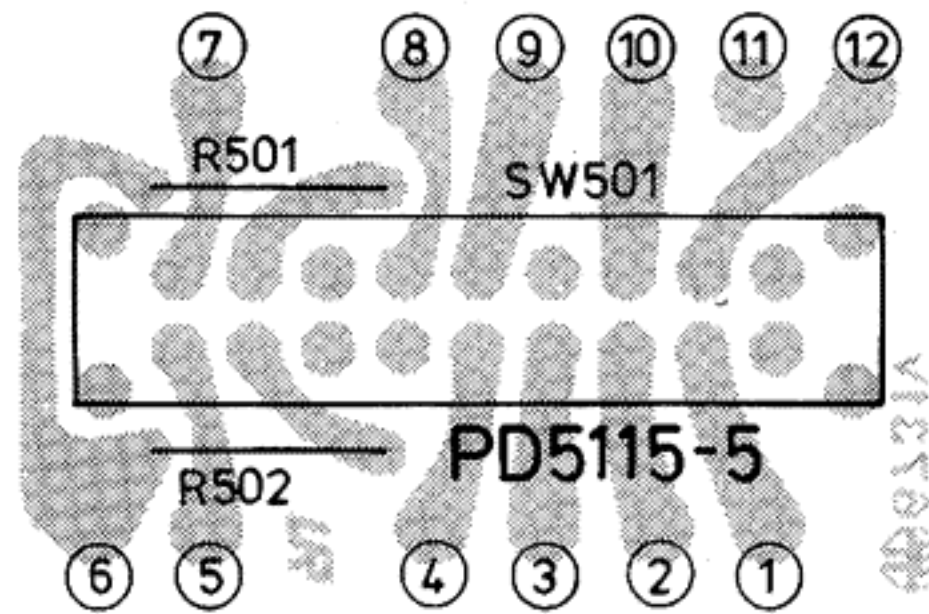

PD-5115-6

Symbol No.	Parts No.	Description & Specification
D601	TD0002	IN4002
D602	TD0002	IN4002
LY602	AY0001	MAT2B-CH
LY603	AY0001	MAT2B-CH
SW601	SS5023	SSB06207S

PD5115-6

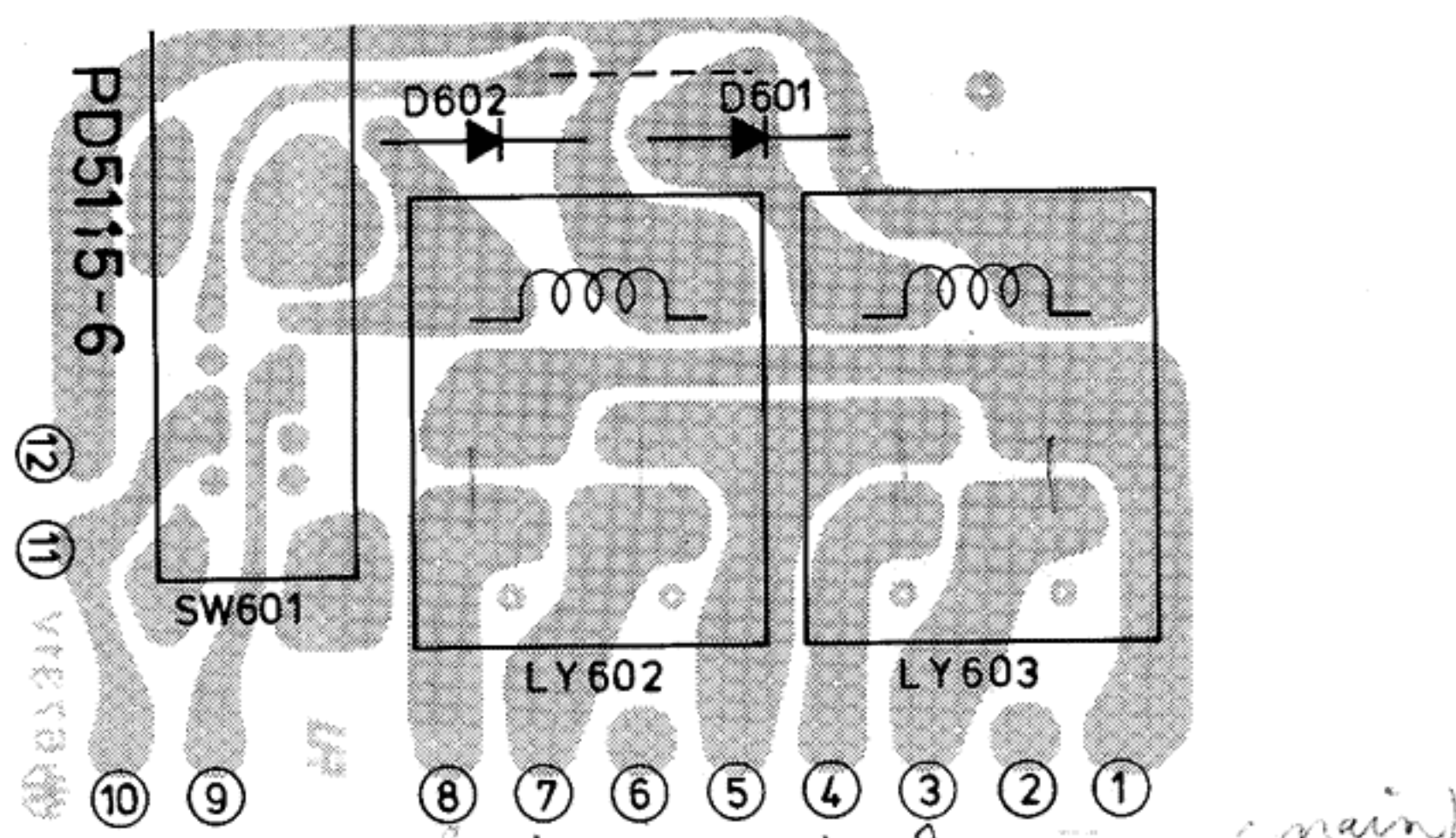



PD-5115-7

Symbol No.	Parts No.	Description & Specification
SW701	SL5014	SLR523 NS

PD5115-7

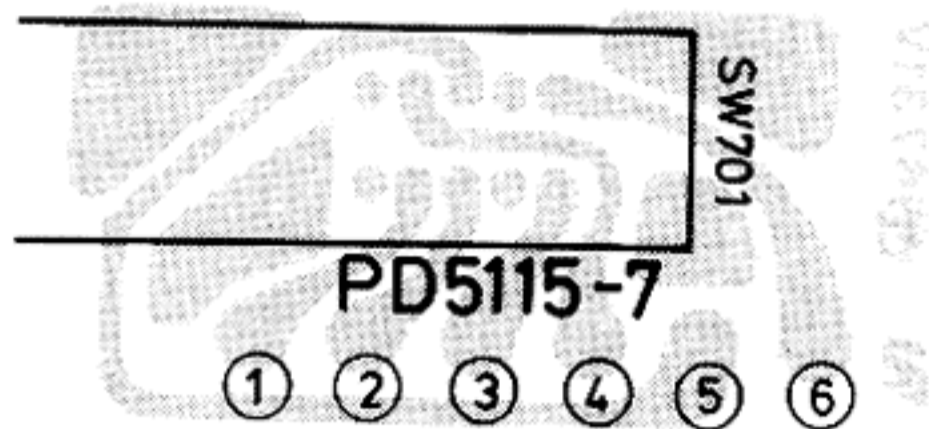

PD-5115-8

Symbol No.	Parts No.	Description & Specification
F801	! BF0119	E MF60NR-5A
F802	! BF0214	S 5x20 5AT
F805	! BF0082	U ULCS-MF61ML 5A
F806		
F803	! BF0113	E MF60NR-1A
F804	! BF0208	S 5x20 1AT
	! BF0075	U ULCS-MF61M-1A
P.B Fuse	! AH0003	E S-N5051
Holder	! AH0004	S S-N5053
	! AH003	U S-N5053

PD5115-8

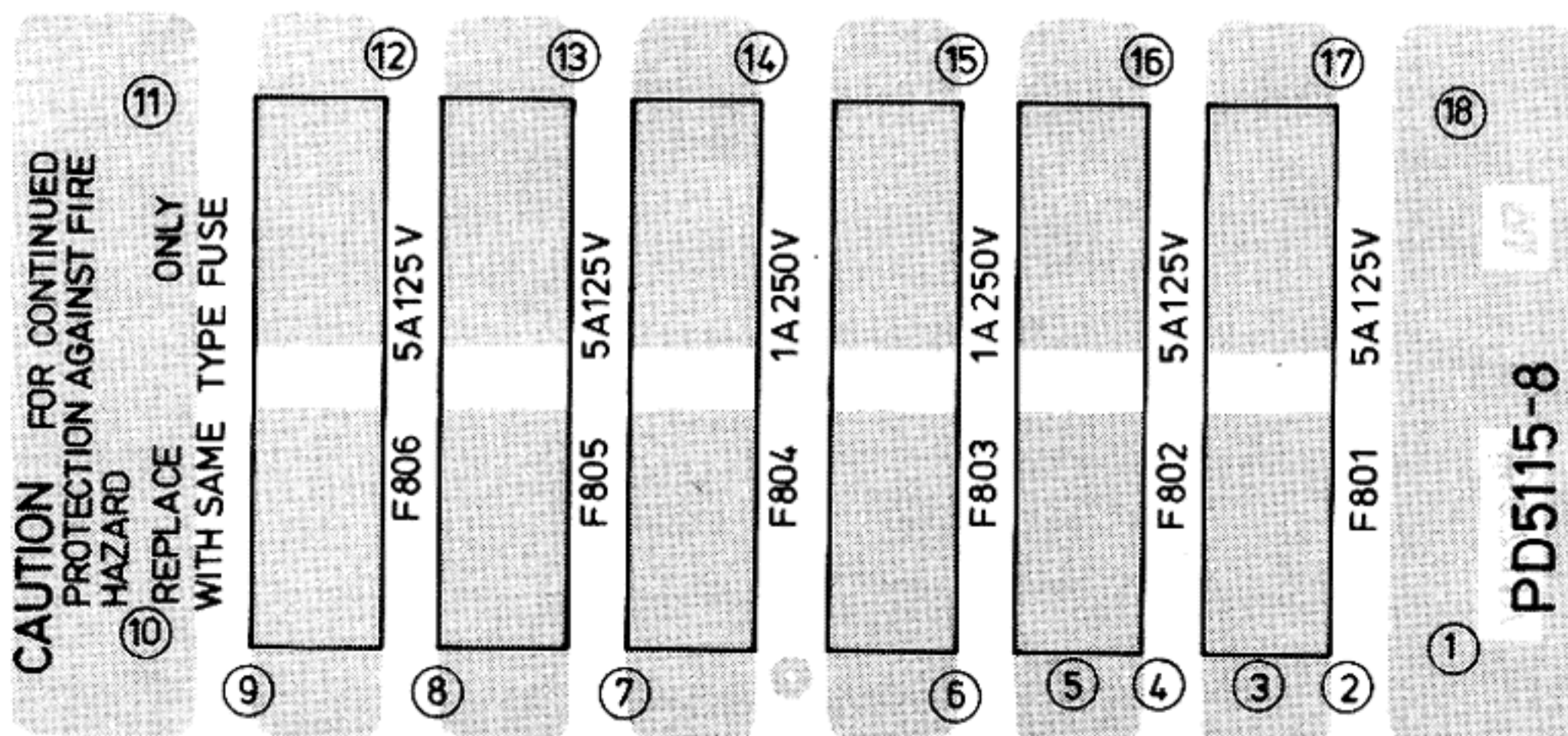

R01 a,b	!	RS5014	47K $\Omega$	$\pm 5\%$	3W	F.P.O
C01 a,b		CE5061	15000 $\mu$ F		80V	E
C02 a,b	{	CQ0955	3.3 $\mu$ F	$\pm 100\%$	100V	MM
		CQ2011	3.3 $\mu$ F	$\pm 100\%$	125V	MM
C03 a,b	!	CU0041	E	0.022 $\mu$ F	AC250V	MP
	!	CU0041	S		AC250V	MP
	!	CU0075	U	2200pF	AC125V	C
D01		TD0196	SLR30UR			
D02		TD0122	S15VB40			
VR01 a,b	{	RV5061	50K $\Omega$	(A)		
		RV5066	200K $\Omega$	(A)		
Power Trans	!	PT5086	E	P-2437		
	!	PT5085	S	P-2436		
	!	PT5084	U	P-2435		
	!	PT5099	U	P-2488		
F01	!	BF0117	EK	MF60NR	3A	
	!	BF0121	EZ	MF60NR	6A	
	!	BF0212	S	5x20	3.15AT	
	!	BF0083	U	ULCS-MF61ML-6A		
Fuse Holder	!	AH0016	E	X-N1157		
	!	AH0019	S	X-N1153		
	!	AH0016	U	X-N1157		
F02 a,b	!	BF0217	S	5x20	0.08AT	
Fuse Holder	!	AH0019	S	X-N1153		
		CQ0195	2400pF	$\pm 5\%$	125V	P

ADD. for C02a,b

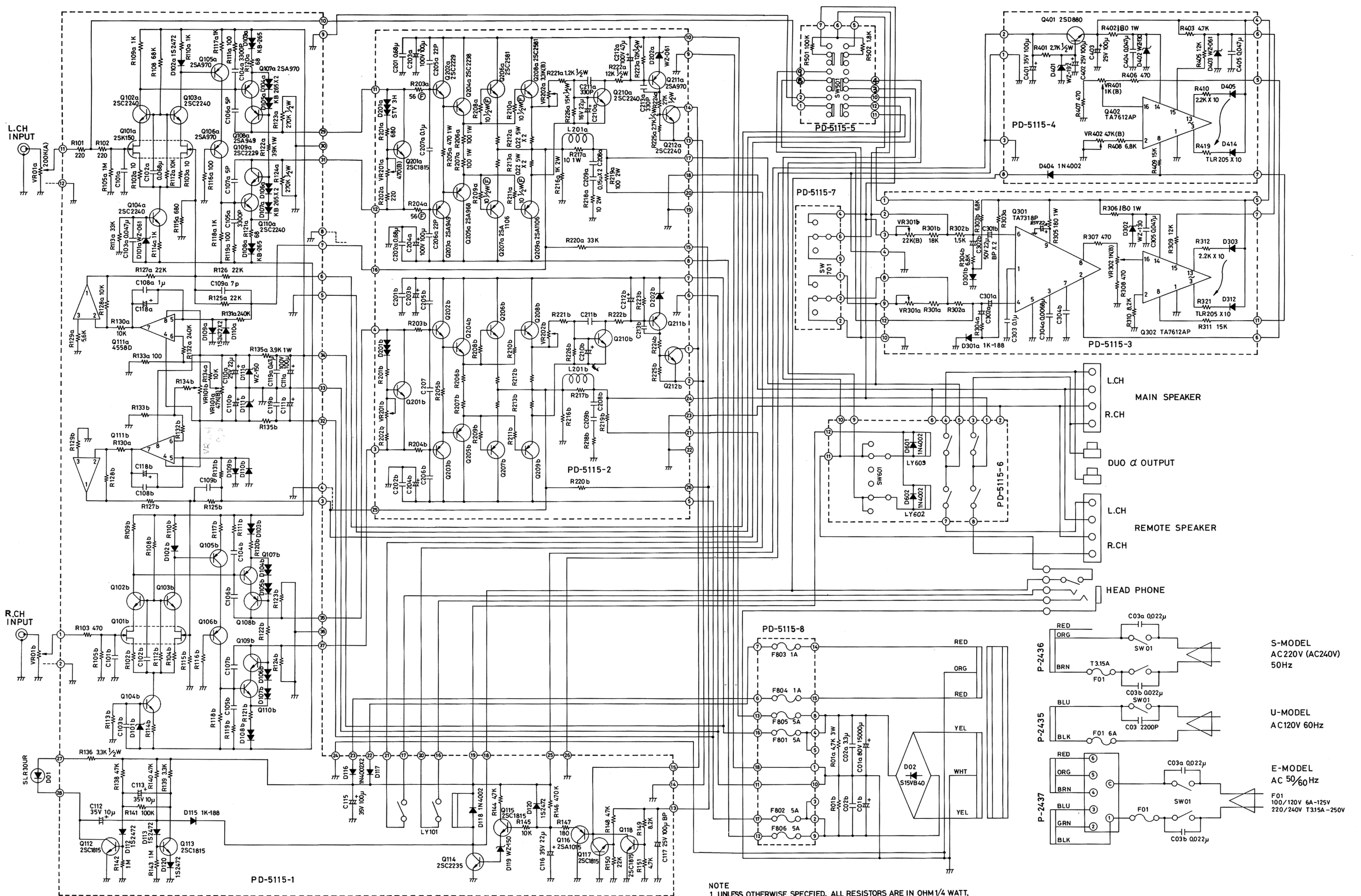

NOTE  
 1. UNLESS OTHERWISE SPECIFIED, ALL RESISTORS ARE IN OHM/4 WATT,  
 ALL CAPACITORS ARE IN FARAD.  
 2. TRANSISTORS AND DIODES MAY BE REPLACED WITH ANY TYPE HAVING  
 COMPAREBLE RATINGS.  
 3. DUE TO CONTINUED IMPROVEMENTS LUX RESERVE THE RIGHT TO ALTER  
 THE CIRCUIT OR SPECIFICATION.

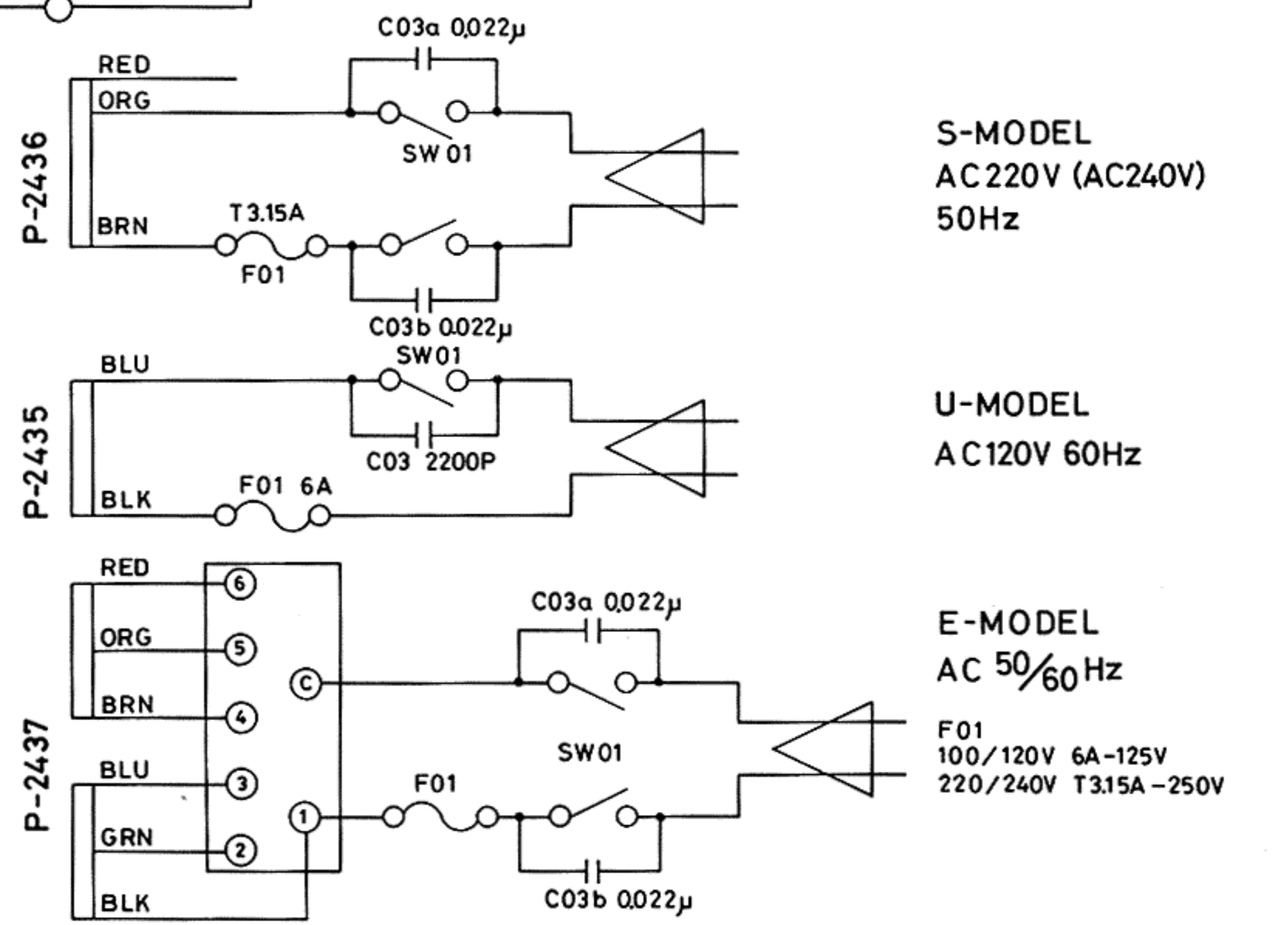

**M-120A**

# **LUX CORPORATION, JAPAN**

1-1, 1-CHOME, SHINSENRI-NISHIMACHI, TOYONAKASHI,  
OSAKA, JAPAN PHONE: 06-834-0004 TELEX: J63694