

SERVICE MANUAL

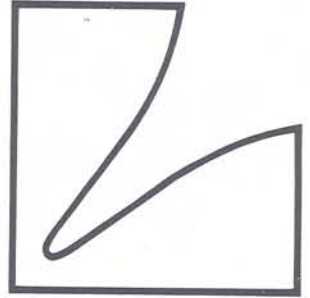

Stereo Integrated Amplifier

LV-92

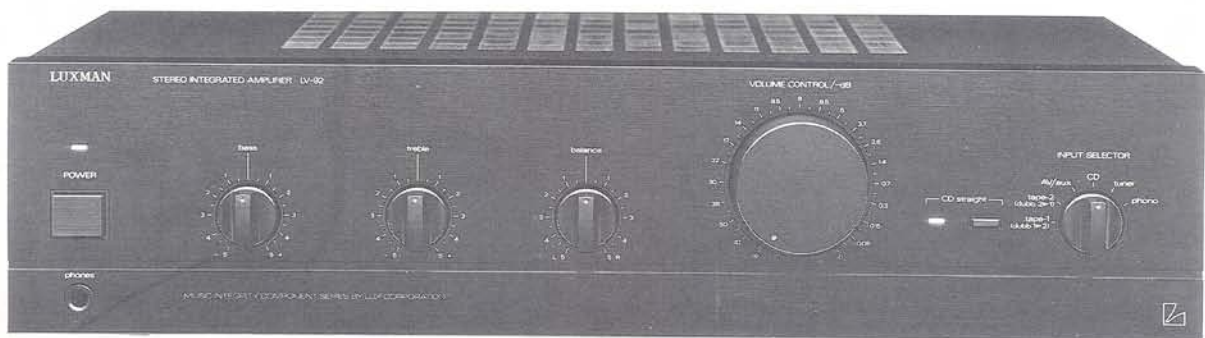

Contents

Specifications	3
Parts Locations and Disassembly Instructions	4 to 7
Block Diagram	8
Adjustment Locations	9
Adjustment Procedures	10
Schematic Diagram	11 to 13
Parts Layout on P.C. Boards and Wiring Diagram	14 to 16
Electrical Parts List	17 to 20
Packing Assembly Parts List	21
Packing Method View	21
Cabinet Assembly Parts List	22
Exploded View (Cabinet)	23 to 24
Semi-Conductor Lead Identifications	25

Specifications

Power-Output.....	35W (0.05% THD at 20 Hz — 20 kHz)
Input Sensitivity (1 kHz).....	PHONO: $2.5 \pm 0.25\text{mV}$, CD: $150 \pm 15\text{mV}$ TUNER: $150 \pm 15\text{mV}$, AV/AUX: $150 \pm 15\text{mV}$ TAPE 1: $150 \pm 15\text{mV}$ TAPE 2: $150 \pm 15\text{mV}$
Input Impedance (1 kHz)	PHONO: 47K ohm, CD: 47K ohm TUNER: 47K ohm, AV/AUX: 47K ohm TAPE 1: 47K ohm TAPE 2: 47K ohm
Frequency Response.....	PHONO(Rec Out): 100 Hz +13.09 ± 1 dB PHONEO(Rec Out): 10 kHz - 13.73 ± 1 dB AV/AUX (Speaker Terminal): 10 Hz - 70 kHz +1 - 3 dB
Signal to Noise Ratioo	PHONO: 76 dB, CD: 89 dB, TUNER: 89 dB AV/AUX: 89 dB, TAPE 1: 89 dB TAPE 2: 89 dB
Power Supply	AC 220/240V (50/60 Hz)
Power Consumption	230W
Semi-Conductors	4 IC's, 25 Transistors, 20 Diodes, 6 Zener Diodes, 2 LED's
Dimension.....	438(W) x 110(H) x 278(D) mm
Weight (Net)	6.0 kg

NOTE: Due to continuing product improvement, specifications and design are subject to change without notice.

Parts Locations and Disassembly Instructions

Figure 1

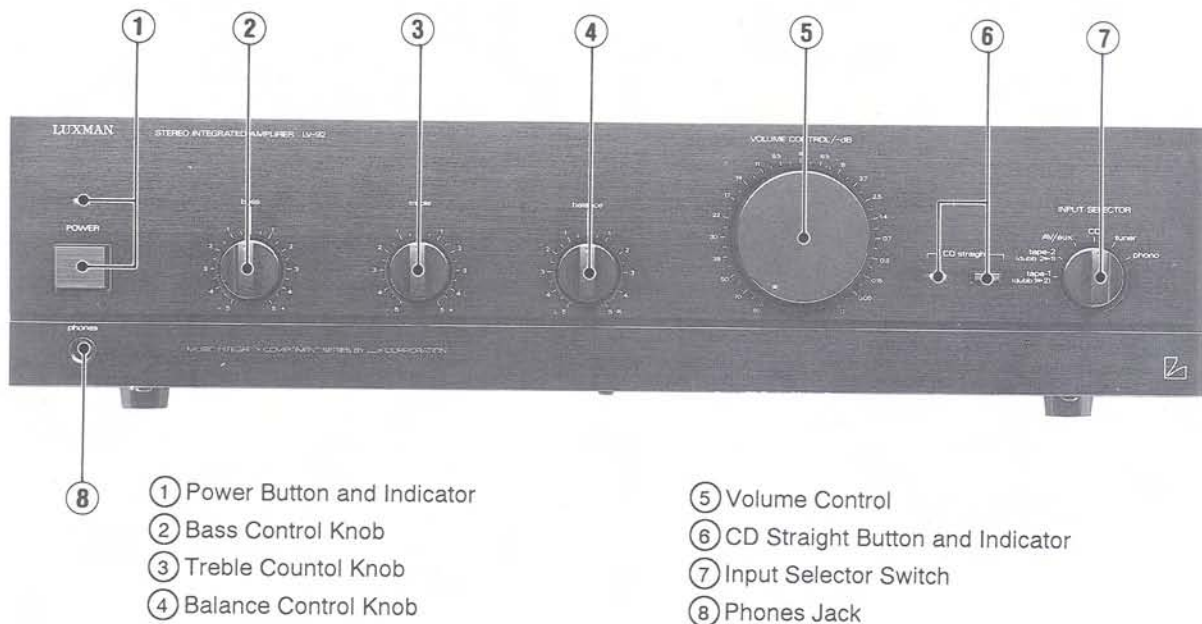

Figure 2

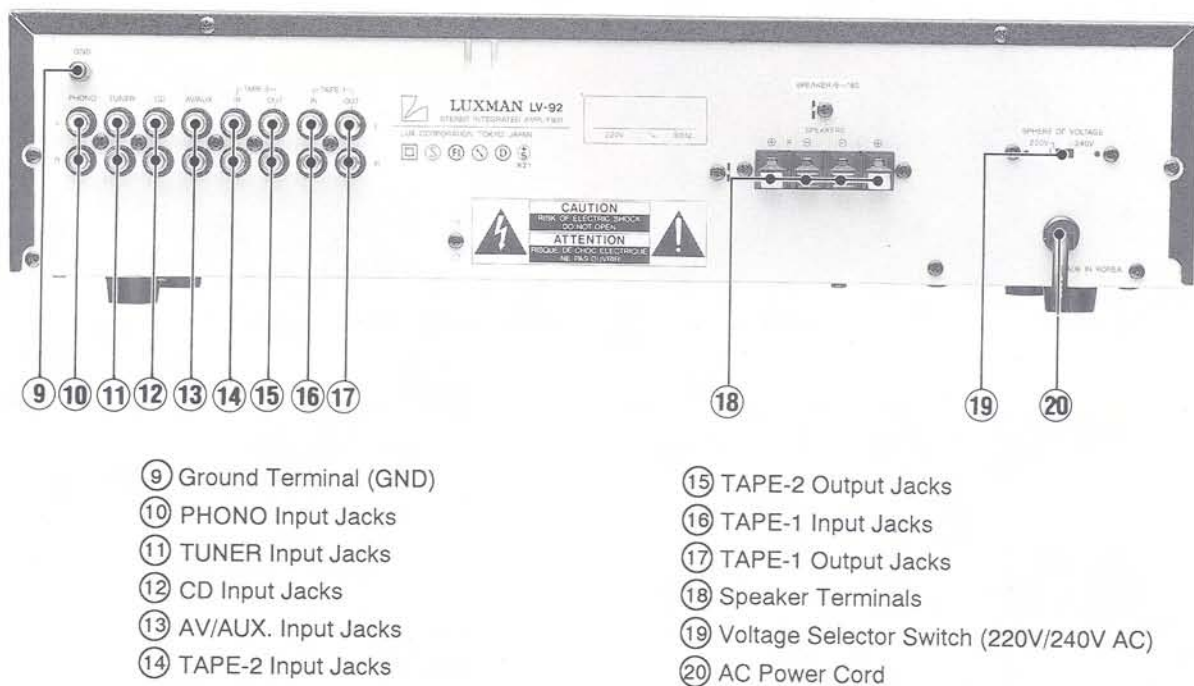
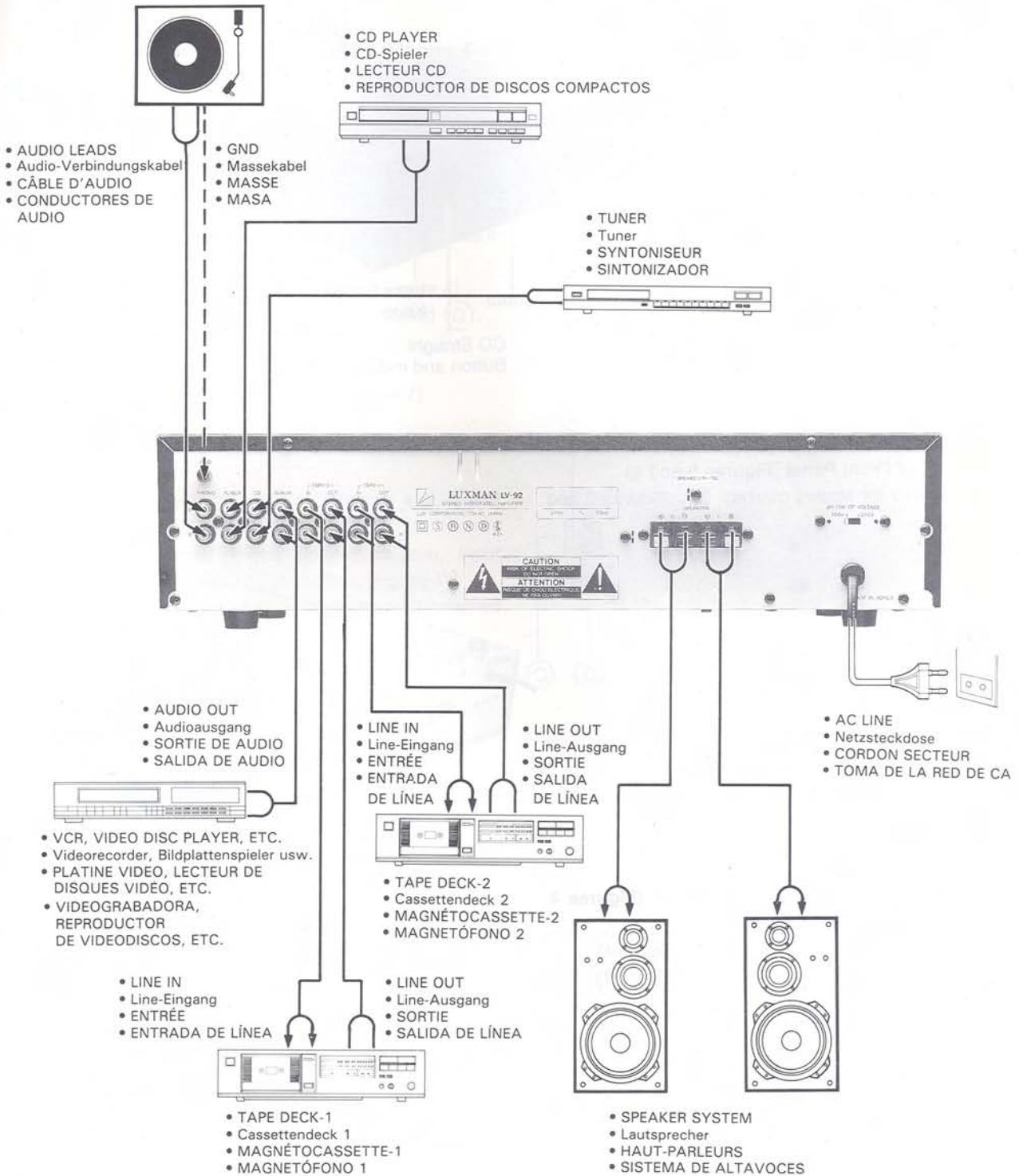

Figure 3

- TURNTABLE (MM cartridge)
 - * When an MC type cartridge is used, it requires a setup transformer or head amplifier to match the sensitivity of the phono input jacks.
- Plattenspieler mit Magnetsystem-Tonabnehmer (MM)
 - * Bei Verwendung eines dynamischen Tonabnehmers wird ein Transformator oder ein Vorverstärker benötigt.

- PLATINE TOURNE-DISQUE (Cellule à bobine mobile (MM))
 - * Quand vous utilisez la tête de lecture de type MC, vous devez utiliser aussi un transformateur ou un amplificateur principal afin d'adapter la sensibilité aux prises d'entrée phono.
- GIRADISCOS (Cápsula de imán móvil (MM))
 - * Para emplear una cápsula de de tipo bobina móvil (MC), necesitará un transformador elevador o un preamplificador a fin de acoplar la sensibilidad con las tomas de entrada para el giradiscos.



1. Removal of Top Cover (Figures 4 and 5)

- (1) Remove six screws marked (A). (Figures 4 and 5)
- (2) Pull out the Top Cover in the Direction of the arrow. (Figure 4)

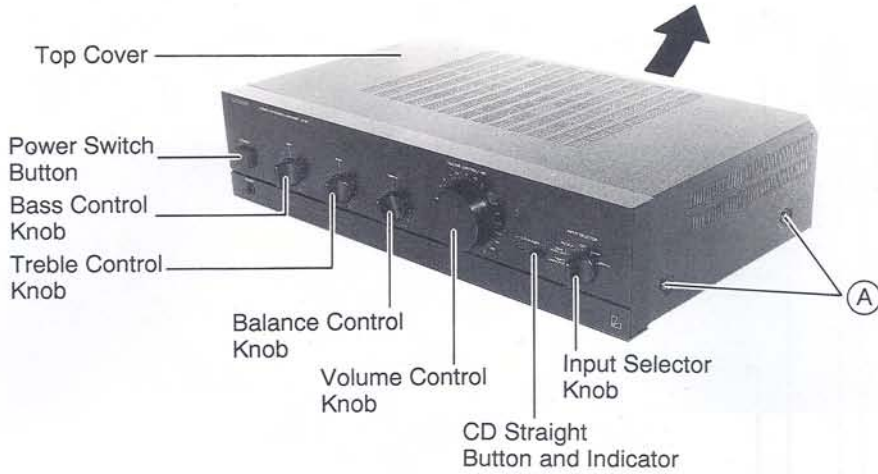

Figure 4

2. Removal of Front Panel (Figures 5 and 6)

- (1) Remove six screws marked B. (Figures 5 and 6)

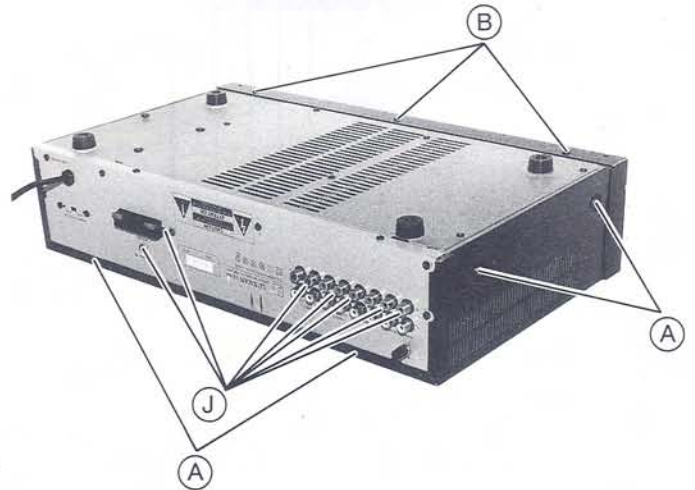

Figure 5

3. Removal of Power Switch P.C. Board (Figures 4 and 7)

- (1) Remove the Power Switch Knob. (Figure 4)
- (2) Remove two screws marked (C). (Figure 7)

4. Removal of Headphone P.C. Board (Figure 7)

- (1) Remove a stopper securing the phones jack marked (D).

5. Removal of Power LED P.C. Board (Figure 7)

- (1) Remove a nylon rivet marked (E).

6. Removal of Bass Control P.C. Board (Figures 4 and 7)

- (1) Remove the Bass Control knob. (Figure 4)
- (2) Remove one nut and one washer marked (F). (Figure 7)

7. Removal of Volume Control P.C. Board (Figures 4 and 7)

- (1) Remove the Volume Control knob (Figure 4)
- (2) Remove one nut and one washer marked (G). (Figure 7)

8. Removal of CD LED P.C. Board (Figure 7)

- (1) Remove a nylon rivet marked (H).

9. Removal of Main P.C. Board (Figures 4, 5, 6 and 7)

- (1) Remove three knobs (treble, balance, input selector) and CD straight button. (Figure 4)
- (2) Remove 17 screws (Figures 5, 6 and 7) marked (J).
- (3) Remove six screws marked (K) and remove the Front Chassis. (Figure 7)
- (4) Disconnect all wires from P.C. Board.

10. Removal of Heat Sink from Main P.C. Board (Figure 6)

- (1) Remove two screws marked (L) from the foil side of the Main P.C. Board.
- (2) Remove five screws marked (M).

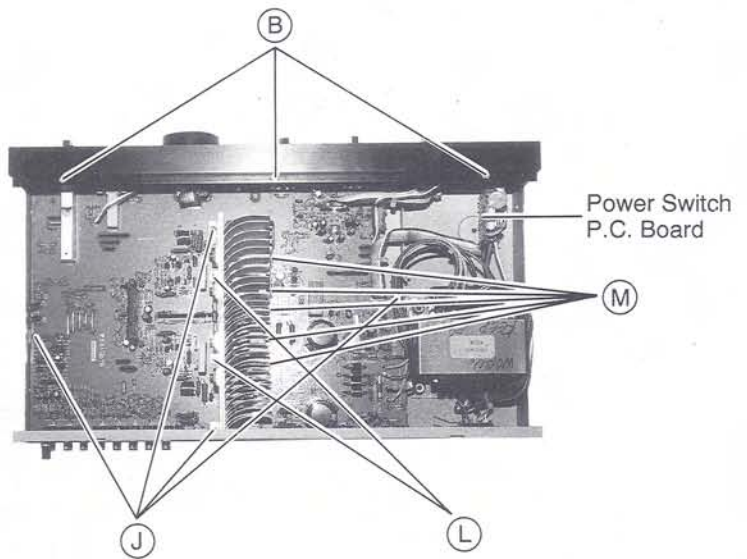

Figure 6

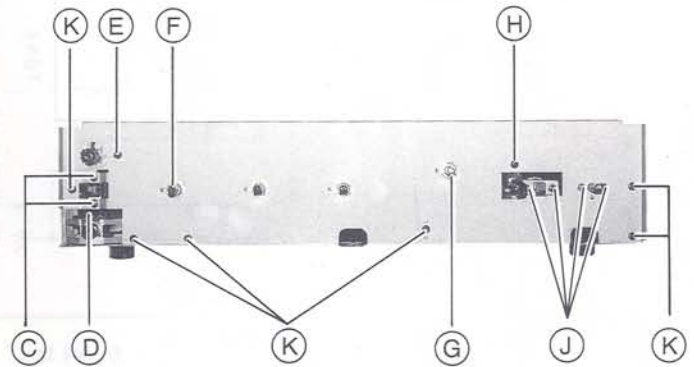
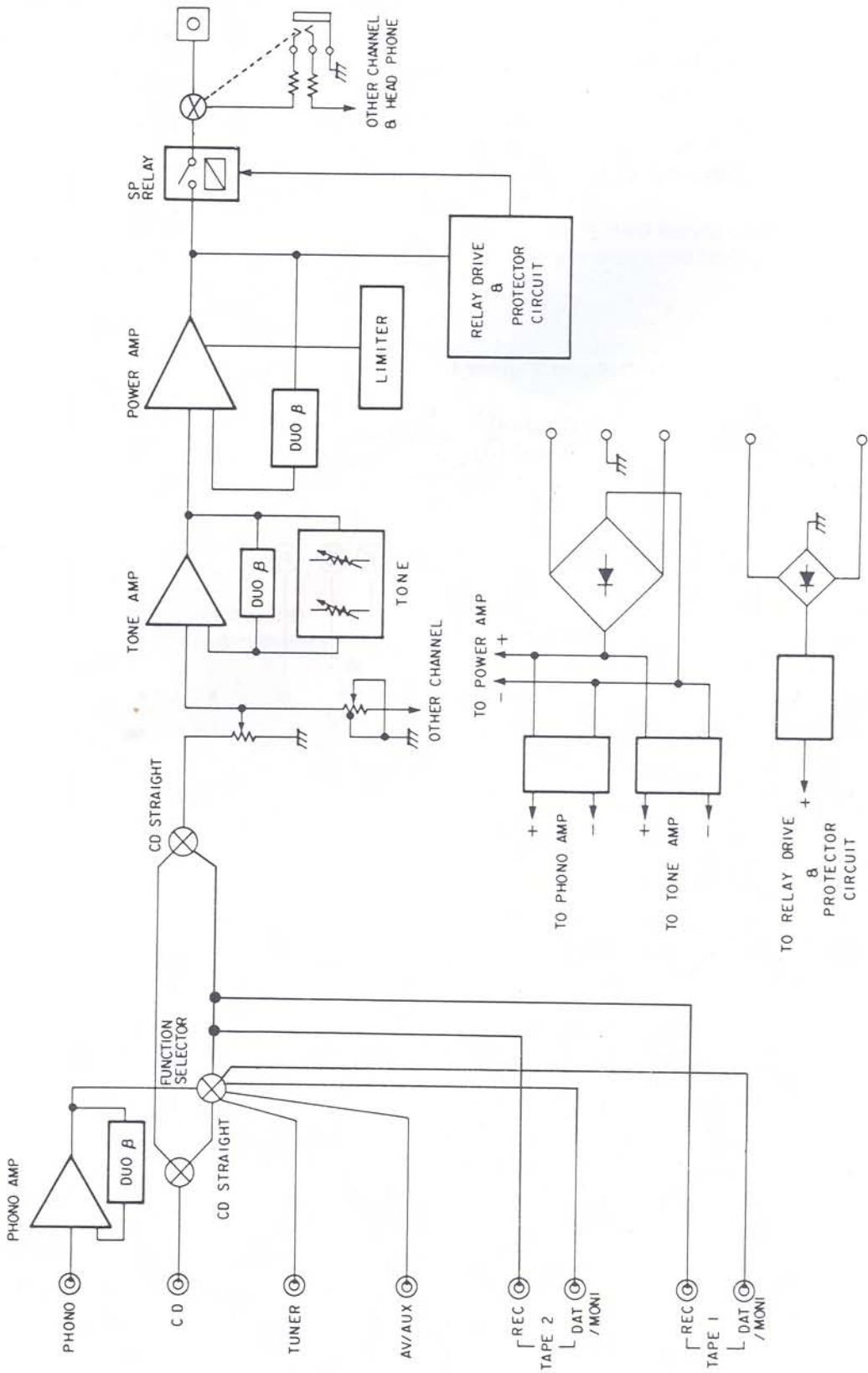

Figure 7

Block Diagram



Adjustment Procedures

(1) Connection

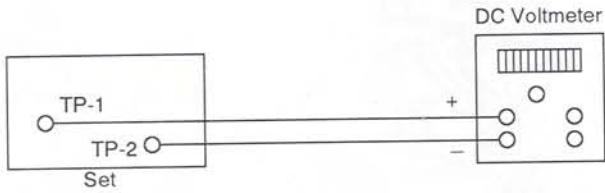

Figure 8

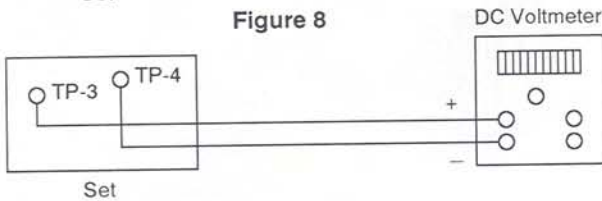

Figure 9

(2) Control Setting

- Power Switch ON
- Function Switch..... CD, TUNER, AV/AUX
- Volume Minimum
- Tone Center

(3) Product

Step	Description	Adjustment Point	Test Point	Connection	Remarks
1	Idle Current	VR301	TP1, TP2	Figure 8	Adjust for $2.5 \pm 0.5\text{mV}$
2	Idle Current	VR302	TP3, TP4	Figure 9	Adjust for $2.5 \pm 0.5\text{mV}$

Adjustment Locations

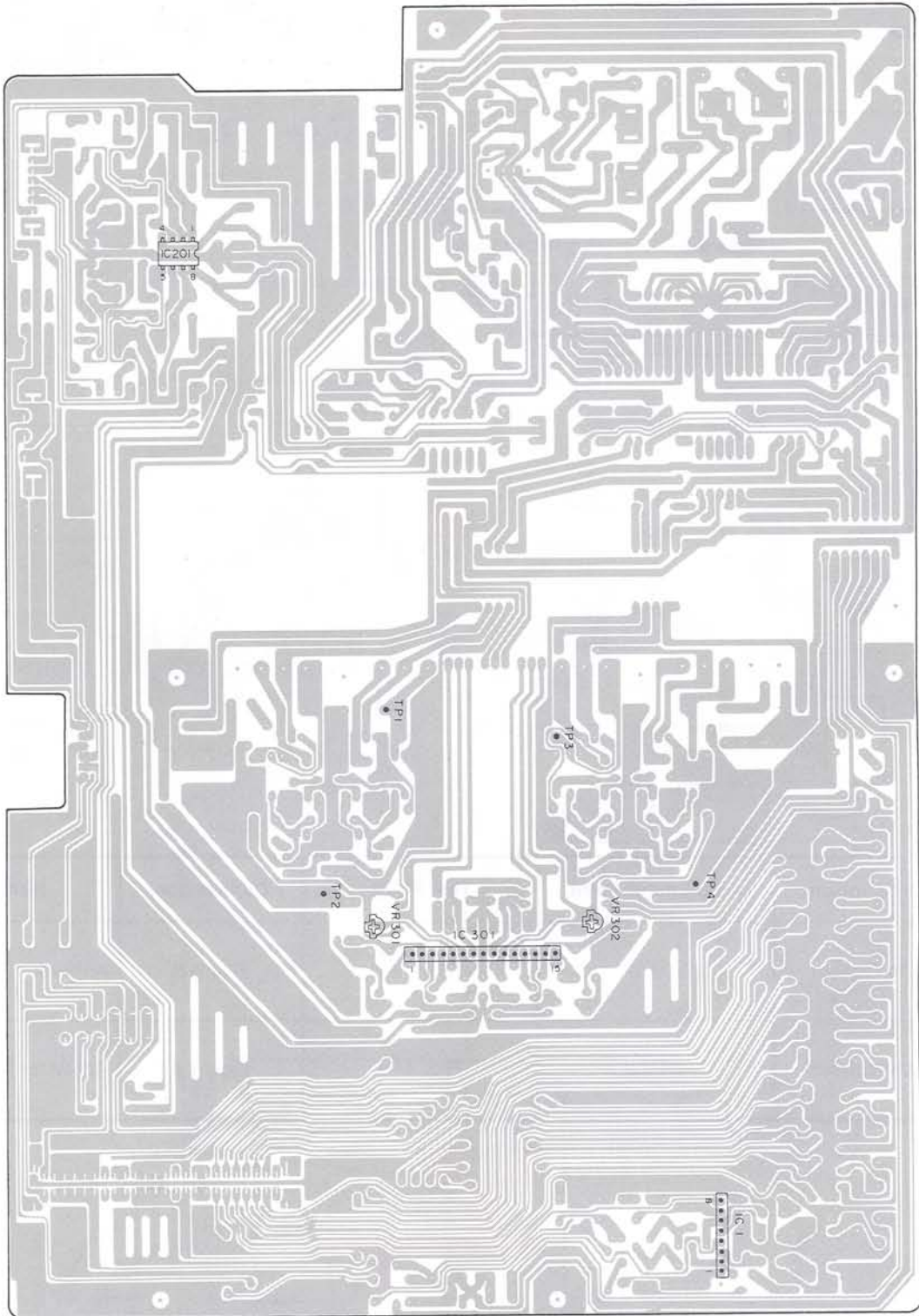

Main P.C.Board

Schematic Diagram

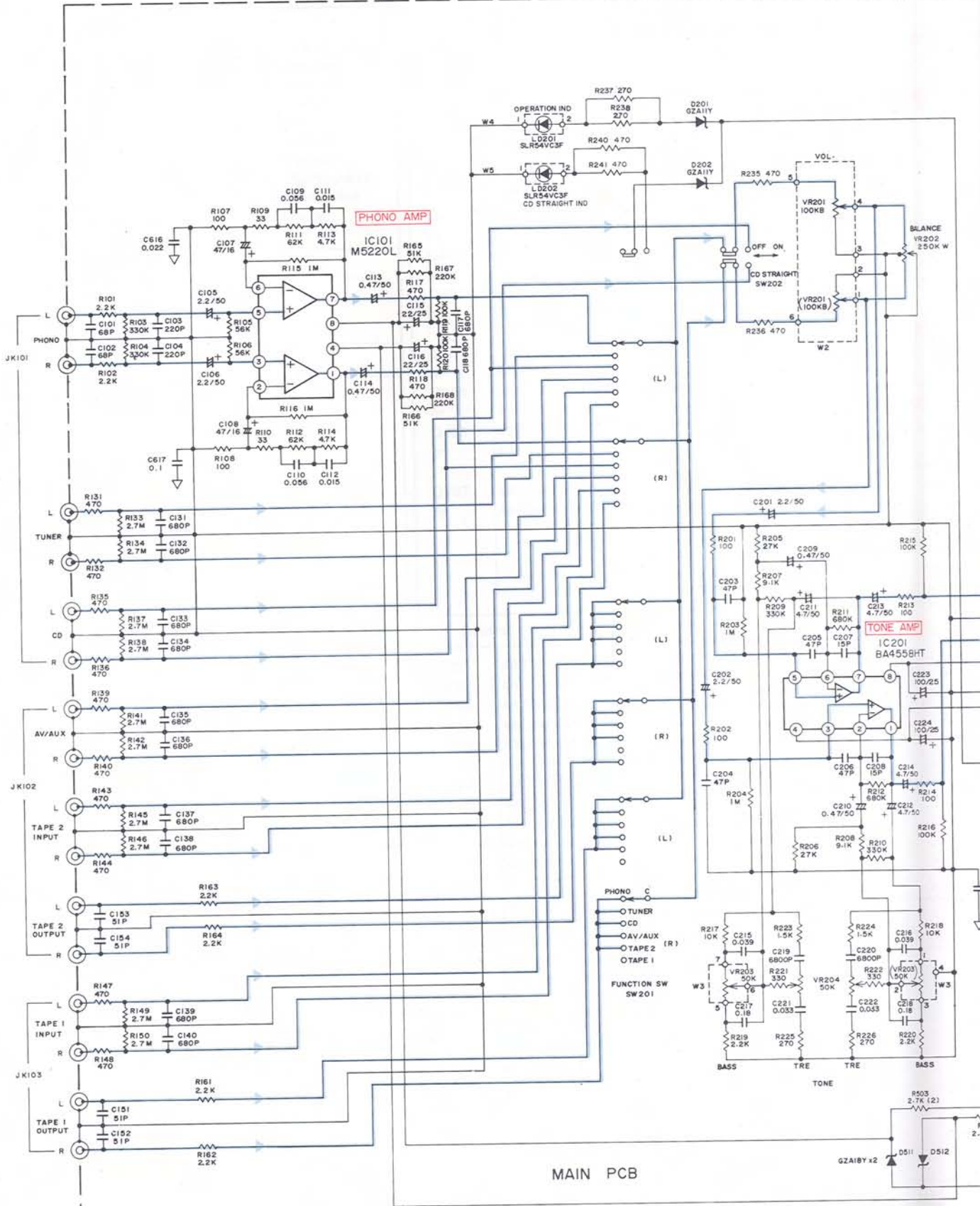

NOTES: (1) ALL RESISTANCE VALUES ARE INDICATED IN "OHM" (K = 10³ OHM, M = 10⁶ OHM).
 (2) ALL CAPACITANCE VALUES ARE INDICATED IN "µF" (P = 10⁶ µF)

A

B - 11 -

C

D

IC101	
1	- 0.71V
2	43.5mV
3	43.0mV
4	- 18.8V
5	43.3mV
8	43.9mV
7	- 0.71V
8	18.4V

IC201	
1	12.7mV
2	38.9mV
3	38.8mV
4	- 15.5V
5	38.8mV
8	38.7mV
7	12.2mV
8	15.4V

IC301	
1	- 61mV
2	- 62.4mV
3	38.5V
4	38.5V
5	- 1.14V
6	1.12V
7	- 37.4V
8	0V
9	37.4V
10	1.11V
11	- 1.14V
12	38.5V
13	38.7V
14	- 80.7mV
15	- 58.8mV

IC501	
IN	OUT
21.3V	14.9V

	E	C	B
Q301	0.55V	39.6V	1.11V
Q302	0.54V	39.8V	1.11V
Q303	- 0.58V	- 39.6V	- 1.13V
Q304	- 0.58V	- 39.6V	- 1.14V
Q305	- 0.60V	39.6V	0.55V
Q306	- 0.63V	39.8V	0.54V
Q307	- 12.7mV	- 39.6V	- 0.58V
Q308	- 11.4mV	- 39.6V	- 0.58V
Q311	- 1.13V	1.11V	- 0.47V
Q312	- 1.14V	1.11V	- 0.47V
Q341	0.97V	- 8.4mV	0.97V
Q342	0.97V	- 8.9mV	0.96V
Q343	- 1.00V	- 9.4mV	- 0.99V
Q344	- 1.01V	- 8.9mV	- 1.00V
Q345	- 9.3mV	0.96V	- 8.3mV
Q346	- 8.9mV	0.97V	- 8.5mV
Q347	- 9.3mV	- 12.4mV	- 0.99V
Q348	- 8.9mV	- 11.2mV	- 1.00V
Q401	1.8mV	5.34V	- 2.4mV
Q402	- 2.4mV	5.34V	1.8mV
Q403	5.34V	1.8mV	5.34V
Q404	1.8mV	5.34V	0.46V
Q405	0.9mV	5.34V	- 1.97V
Q406	0.72V	5.57V	1.35V
Q407	1.7mV	31.0mV	0.72V

Layout on P.C. Boards and Wiring Diagram

Main P.C. Board

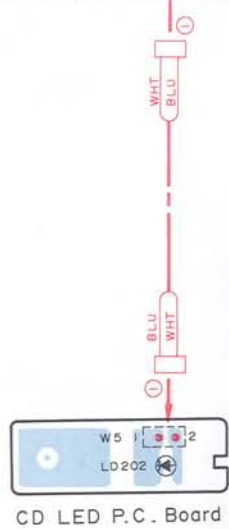
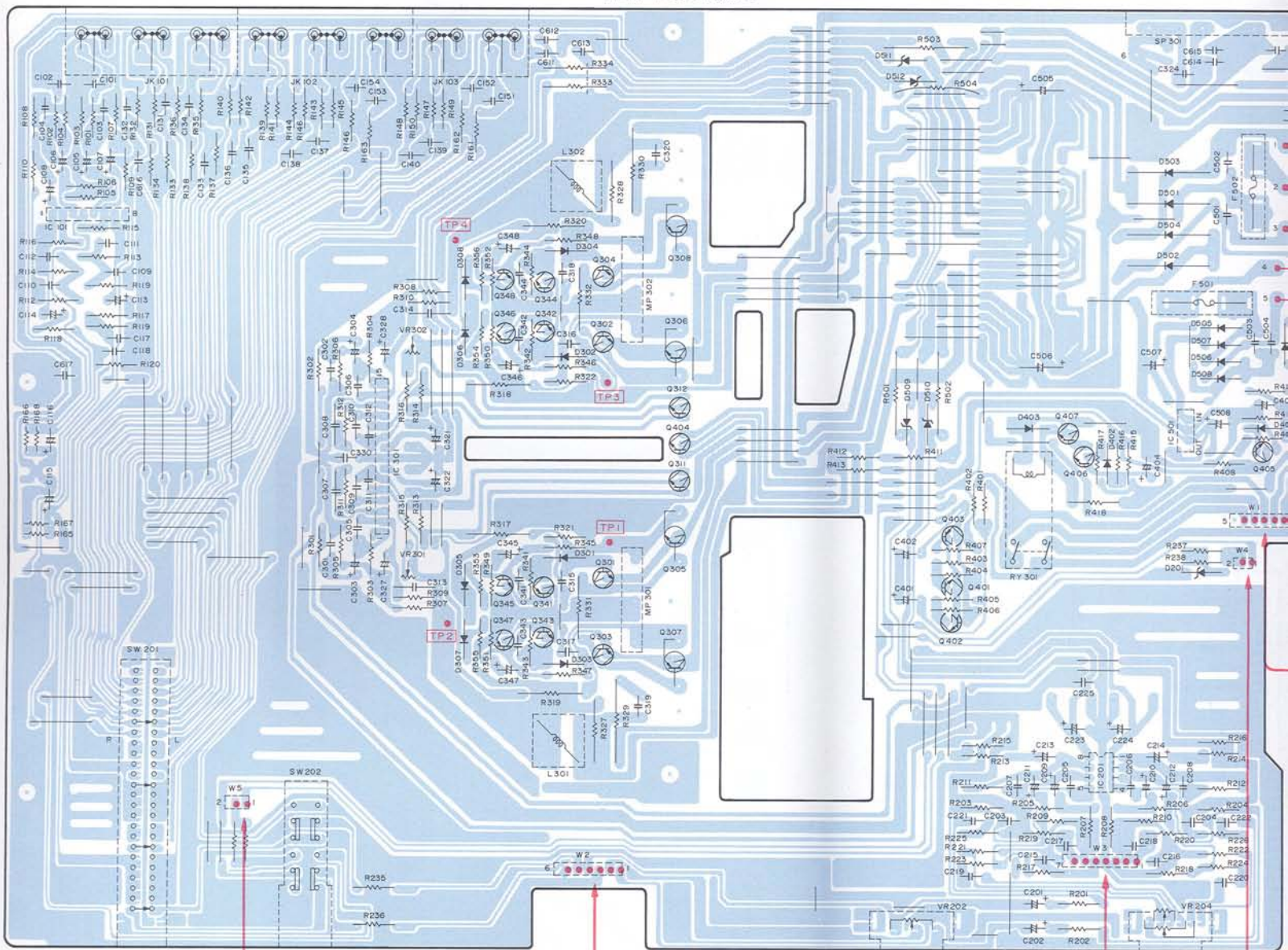

CD LED P.C. Board

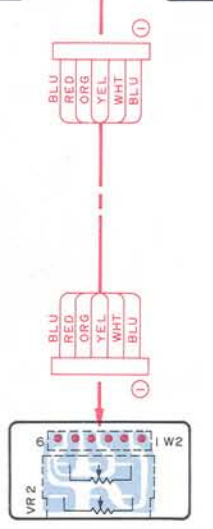

Main Volume P.C. Board

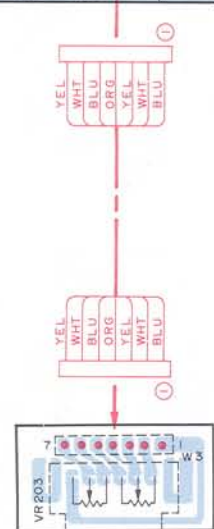

Bass Volume P.C. Board

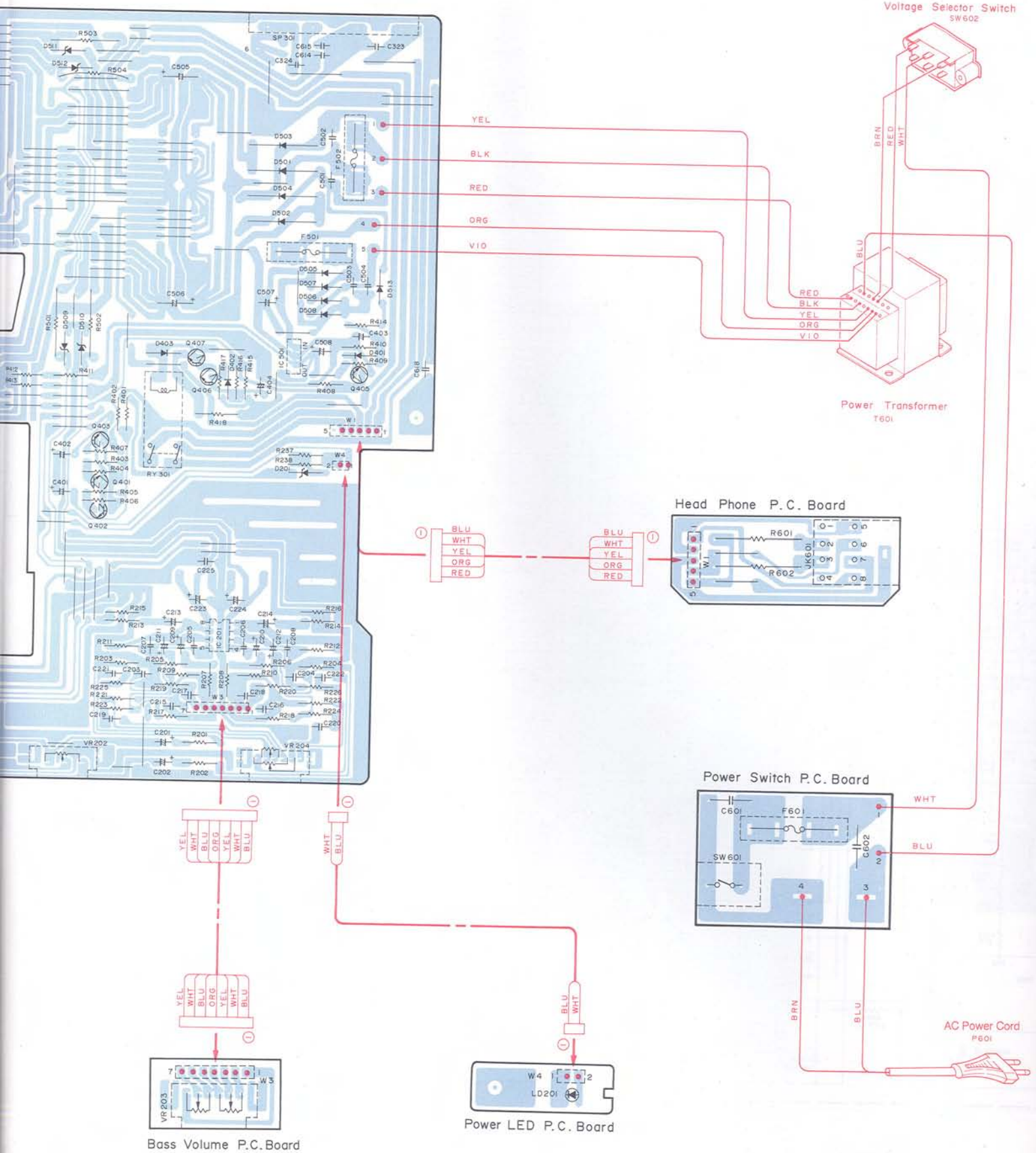

Electrical Parts List

Resistor : Carbon resistors under 1/4 watts are not mentioned in the parts list, please confirm them by schematic diagram.
 Capacitor : μ F = microfarads, pF = picofarads

Abbreviations					Symbol No.	Part No.	Description		
RES. = Resistor C.F. = Carbon Film M.F. = Metal Film M.O. = Metal Oxide Film M.P. = Metal Plate CTM. = Cement Resistor TR. = Transistor TRANS. = Transformer CP. = Chip CAP. = Capacitor ELY. = Electrolytic CER. = Ceramic MYL. = Mylar TAN. = Tantalum POLY. = Polystyrol PP. = Polypropylene PLT. = Polyethylene STR. = Styrene M-PL. = M-Plastic									
Symbol No.	Part No.	Description							
Main P. C. Board									
IC's									
IC101	51E08012S01	M5220L			Q346	48S43525F03	2SC1815		
IC201	51T65380F01	BA4558HT			or	48E04784S04	KTC1815		
IC301	51E08013S01	STK3042M-3			Q347	48T51118F02	2SA1015		
IC501	51E08014S01	MC78M15CT			or	48E04785S04	KTA1015		
Transistors									
Q301	48E08018S01	2SD600			Q348	48T51118F02	2SA1015		
Q302	48E08018S01	2SD600			or	48E04785S04	KTA1015		
Q303	48E08019S01	2SB631			Q401	48S43525F03	2SC1815		
Q304	48E08019S01	2SB631			or	48E04784S04	KTC1815		
Q305	48E08016S01	2SC4467			Q402	48S43525F03	2SC1815		
Q306	48E08016S01	2SC4467			or	48E04784S04	KTC1815		
Q307	48E08017S01	2SA1694			Q403	48T51118F02	2SA1015		
Q308	48E08017S01	2SA1694			or	48E04785S04	KTA1015		
Q311	48S43525F06	2SC1815			Q404	48S43525F03	2SC1815		
or	48E04784S05	KTC1815			or	48E04784S04	KTC1815		
Q312	48S43525F06	2SC1815			Q405	48S43525F03	2SC1815		
or	48E04784S05	KTC1815			or	48E04784S04	KTC1815		
Q341	48T51118F02	2SA1015			Q406	48S43525F03	2SC1815		
or	48E04785S04	KTA1015			or	48E04784S04	KTC1815		
Q342	48T51118F02	2SA1015			Q407	48T45274F02	2SC2120		
or	48E04785S04	KTA1015			or	48E08023S01	KTC2120		
Q343	48S43525F03	2SC1815			Diodes				
or	48E04784S04	KTC1815			D201	48E04647S01	Zener, GZA11		
Q344	48S43525F03	2SC1815			D202	48E04647S01	Zener, GZA11		
or	48E04784S04	KTC1815			D301	48E04616S01	1N4148		
Q345	48S43525F03	2SC1815			D302	48E04616S01	1N4148		
or	48E04784S04	KTC1815			D303	48E04616S01	1N4148		
					D304	48E04616S01	1N4148		
					D305	48E04616S01	1N4148		
					D306	48E04616S01	1N4148		
					D307	48E04616S01	1N4148		
					D308	48E04616S01	1N4148		
					D401	48E04616S01	1N4148		
					D402	48E04616S01	1N4148		
					D403	48S40477U02	1N4002		
					D501	48E08024S01	1N5402		
					D502	48E08024S01	1N5402		
					D503	48E08024S01	1N5402		
					D504	48E08024S01	1N5402		
					D505	48S40477U02	1N4002		
					D506	48S40477U02	1N4002		
					D507	48S40477U02	1N4002		

Symbol No.	Part No.	Description			Symbol No.	Part No.	Description		
D508	48S40477U02	1N4002			C116	23E04636S02	ELY., 22 μ F/25V		
D509	48E01750S01	Zener, GZA15			C117	21E04734S02	CER., 680pF		
D510	48E01750S01	Zener, GZA15			C118	21E04734S02	CER., 680pF		
D511	48E01752S01	Zener, GZA18			C131	21E04623S02	CER., 680pF		
D512	48E01752S01	Zener, GZA18			C132	21E04623S02	CER., 680pF		
D513	48S40477U02	1N4002			C133	21E04623S02	CER., 680pF		
					C134	21E04623S02	CER., 680pF		
					C135	21E04623S02	CER., 680pF		
					C136	21E04623S02	CER., 680pF		
					C137	21E04623S02	CER., 680pF		
Coils/Relay					C138	21E04623S02	CER., 680pF		
L301	24E04618S01	Air Coil L/R			C139	21E04623S02	CER., 680pF		
L302	24E04618S01	Air Coil L/R			C140	21E04623S02	CER., 680pF		
RY301	80E04619S01	Relay			C151	21E04734S03	CER., 51pF		
or	80E08099S01	Relay			C152	21E04734S03	CER., 51pF		
Jacks					C153	21E04734S03	CER., 51pF		
JK101	09E08090S01	RCA Jack			C154	21E04734S03	CER., 51pF		
JK102	09E08090S01	RCA Jack			C201	23E04635S08	ELY., 2.2 μ F/50V		
JK103	09E07996S01	RCA Jack			C202	23E04635S08	ELY., 2.2 μ F/50V		
Capacitors					C203	21E04622S02	CER., 47pF		
C101	21E04622S01	CER., 68pF			C204	21E04622S02	CER., 47pF		
C102	21E04622S01	CER., 68pF			C205	21E04622S02	CER., 47pF		
C103	21E04623S01	CER., 220pF			C206	21E04622S02	CER., 47pF		
C104	21E04623S01	CER., 220pF			C207	21E04622S04	CER., 15pF		
C105	23E04635S08	ELY., 2.2 μ F/50V			C208	21E04622S04	CER., 15pF		
C106	23E04635S08	ELY., 2.2 μ F/50V			C209	23E04635S04	ELY., 0.47 μ F/50V		
C107	23E04754S04	ELY., 22 μ F/16V			C210	23E04635S04	ELY., 0.47 μ F/50V		
C108	23E04754S04	ELY., 22 μ F/16V			C211	23E04635S07	ELY., 4.7 μ F/50V		
C109	08E04735S19	MYL., 0.056 μ F			C212	23E04635S07	ELY., 4.7 μ F/50V		
C110	08E04735S19	MYL., 0.056 μ F			C213	23E04635S07	ELY., 4.7 μ F/50V		
C111	08E04735S06	MYL., 0.015 μ F			C214	23E04635S07	ELY., 4.7 μ F/50V		
C112	08E04735S06	MYL., 0.015 μ F			C215	08E04654S01	M-PL., 0.039 μ F		
C113	23E04635S04	ELY., 0.47 μ F/50V			C216	08E04654S01	M-PL., 0.039 μ F		
C114	23E04635S04	ELY., 0.47 μ F/50V			C217	08E04654S02	M-PL., 0.18 μ F		
C115	23E04636S02	ELY., 22 μ F/25V			C218	08E04654S02	M-PL., 0.18 μ F		
					C219	08E04654S03	M-PL., 6800pF		
					C220	08E04654S03	M-PL., 6800pF		
					C221	08E04654S04	M-PL., 0.033 μ F		
					C222	08E04654S04	M-PL., 0.033 μ F		
					C223	23E04636S02	ELY., 22 μ F/25V		
					C224	23E04636S02	ELY., 22 μ F/25V		
					C225	21E04631S05	CER., 0.1 μ F		
					C301	21E04623S03	CER., 330pF		
					C302	21E04623S03	CER., 330pF		
					C303	23E04635S08	ELY., 2.2 μ F/50V		
					C304	23E04635S08	ELY., 2.2 μ F/50V		
					C305	21E04734S04	CER., 470pF		
					C306	21E04734S04	CER., 470pF		
					C307	21E04629S01	CER., 1500pF		
					C308	21E04629S01	CER., 1500pF		

Symbol No.	Part No.	Description			Symbol No.	Part No.	Description		
C309	21E04622S02	CER., 47 pF			Resistors				
C310	21E04622S02	CER., 47 pF			R317	06E04639S01	M.O., 33 ohm 1W		
C311	08E04654S07	M-PL., 0.1 μ F			R318	06E04639S01	M.O., 33 ohm 1W		
C312	08E04654S07	M-PL., 0.1 μ F			R319	06E04639S01	M.O., 33 ohm 1W		
C313	21E04622S06	CER., 33 pF			R320	06E04639S01	M.O., 33 ohm 1W		
C314	21E04622S06	CER., 33 pF			R327	06E04639S02	M.O., 10 ohm 1W		
C315	21E04734S10	CER., 100 pF			R328	06E04639S02	M.O., 10 ohm 1W		
C316	21E04734S10	CER., 100 pF			R329	06E04640S01	M.O., 10 ohm 2W		
C317	21E04734S10	CER., 100 pF			R330	06E04640S01	M.O., 10 ohm 2W		
C318	21E04734S10	CER., 100 pF			R331	06E04639S03	M.O., 150 ohm 1W		
C319	08E04735S02	MYL., 0.047 μ F			R332	06E04639S03	M.O., 150 ohm 1W		
C320	08E04735S02	MYL., 0.047 μ F			R333	06E04639S04	M.O., 120 ohm 1W		
C321	23E04635S12	ELY., 22 μ F/50V			R334	06E04639S04	M.O., 120 ohm 1W		
C322	23E04635S12	ELY., 22 μ F/50V			R418	06E05508S07	C.F., 68 ohm 1/2W		
C323	21E04631S01	CER., 0.01 μ F			R501	06E04640S02	M.O., 2.2k ohm 2W		
C324	21E04631S01	CER., 0.01 μ F			R502	06E04640S02	M.O., 2.2k ohm 2W		
C327	23E04636S02	ELY., 22 μ F/25V			R503	06E04640S03	M.O., 2.7k ohm 2W		
C328	23E04636S02	ELY., 22 μ F/25V			R504	06E04640S03	M.O., 2.7k ohm 2W		
C330	21E04631S05	CER., 0.1 μ F			MP301	17E04642S01	CMT., 0.22 ohm x 2 5W		
C341	21E04638S01	CER., 2200 pF			MP302	17E04642S01	CMT., 0.22 ohm x 2 5W		
C342	21E04638S01	CER., 2200 pF			VR202	18E08096S01	Rotary Volume 250KW (Balance)		
C343	21E04638S01	CER., 2200 pF			VR204	18E08097S01	Rotary Volume 50KC (Treble)		
C344	21E04638S01	CER., 2200 pF			VR301	18E04643S01	Semi-fixed Volume 2.2K		
C345	23E04754S01	ELY., 10 μ F/16V			VR302	18E04643S01	Semi-fixed Volume 2.2K		
C346	23E04754S01	ELY., 10 μ F/16V			Switches				
C347	23E04754S01	ELY., 10 μ F/16V			SW201	40E08092S01	Rotary Slide Switch (Function)		
C348	23E04754S01	ELY., 10 μ F/16V			or	40E08095S01	Rotary Slide Switch (Function)		
C401	23E04754S02	ELY., 220 μ F/16V			SW202	40E08093S01	Push Switch (CD Straight)		
C402	23E04754S02	ELY., 220 μ F/16V							
C403	23E08027S01	ELY., 0.47 μ F/50V							
C404	23E04754S08	ELY., 33 μ F/16V							
C501	21E04634S01	CER., 0.047 μ F							
C502	21E04634S01	CER., 0.047 μ F							
C503	21E04634S01	CER., 0.047 μ F							
C504	21E04634S01	CER., 0.047 μ F							
C505	23E04635S02	ELY., 6800 μ F/50V							
C506	23E04635S02	ELY., 6800 μ F/50V							
C507	23E04636S05	ELY., 1000 μ F/25V							
C508	23E04636S04	ELY., 220 μ F/25V							
C611	21E04631S03	CER., 0.022 μ F							
C612	21E04631S03	CER., 0.022 μ F							
C613	21E04631S03	CER., 0.022 μ F							
C614	21E04631S05	CER., 0.1 μ F							
C615	21E04631S05	CER., 0.1 μ F							
C616	21E04631S03	CER., 0.022 μ F							
C617	21E04631S05	CER., 0.1 μ F							
C618	21E04631S04	CER., 0.047 μ F							

Symbol No.	Part No.	Description			Symbol No.	Part No.	Description							
Headphones P. C. Board					CD LED P. C. Board									
Resistors/Jack					LED									
R601 R602 JK601	06E04640S04 06E04640S04 09E04662S01	M.O., 270 ohm 2W M.O., 270 ohm 2W Jack 6.3			LD202	48E04648S01	SLR-54 VC3F (Red)							
Power Switch P. C. Board					Miscellaneous									
Capacitors/Fuse/Switch														
C601 C602 F601 SW601	08E04663S01 08E04663S01 65E04664S01 40E04667S01	Line Cap., AC400V 0.01 μ F Line Cap., AC400V 0.01 μ F Fuse 250V 2A Push Switch (Power)								T601 SW602 P601 F501 F502	25E08110S01 40E08094S01 28E04687S01 65E04644S01 65E04646S01	Trans, Power EI-85, 220/240V Switch, Voltage Selector AC Power Cord Fuse 250V 0.16A Fuse 250V 5A		
Bass VR P. C. Board														
Resistor														
VR203	18E08097S01	Rotary Volume 50KC (Bass)												
Master VR P. C. Board														
Resistor														
VR201	18E08098S01	Rotary Volume 100KB (Master)												
Power LED P. C. Board														
LED														
LD201	48E08025S01	SLR-54 DC3F (Orange)												

Symbol No.	Part No.	Description		
Headphones P. C. Board				
Resistors/Jack				
R601	06E04640S04	M.O., 270 ohm 2W		
R602	06E04640S04	M.O., 270 ohm 2W		
JK601	09E04662S01	Jack 6.3		
Power Switch P. C. Board				
Capacitors/Fuse/Switch				
C601	08E04663S01	Line Cap., AC400V 0.01 μ F		
C602	08E04663S01	Line Cap., AC400V 0.01 μ F		
F601	65E04664S01	Fuse 250V 2A		
SW601	40E04667S01	Push Switch (Power)		
Bass VR P. C. Board				
Resistor				
VR203	18E08097S01	Rotary Volume 50KC (Bass)		
Master VR P. C. Board				
Resistor				
VR201	18E08098S01	Rotary Volume 100KB (Master)		
Power LED P. C. Board				
LED				
LD201	48E08025S01	SLR-54 DC3F (Orange)		

Symbol No.	Part No.	Description		
CD LED P. C. Board				
LED				
LD202	48E04648S01	SLR-54 VC3F (Red)		
Miscellaneous				
T601	25E08110S01	Trans. Power EI-85, 220/240V		
SW602	40E08094S01	Switch, Voltage Selector		
P601	28E04687S01	AC Power Cord		
F501	65E04644S01	Fuse 250V 0.16A		
F502	65E04646S01	Fuse 250V 5A		

Packing Assembly Parts List

Symbol No.	Part No.	Description			Symbol No.	Part No.	Description		
101	56E08268S01	Carton, Packing (IND)							
102	56E04699S01	Tray, Packing (R)							
103	56E04699S02	Tray, Packing (L)							
104	56E04700S01	Bag, High Polyester							
105	68P96552F74	Owner's Manual							

Packing Method View

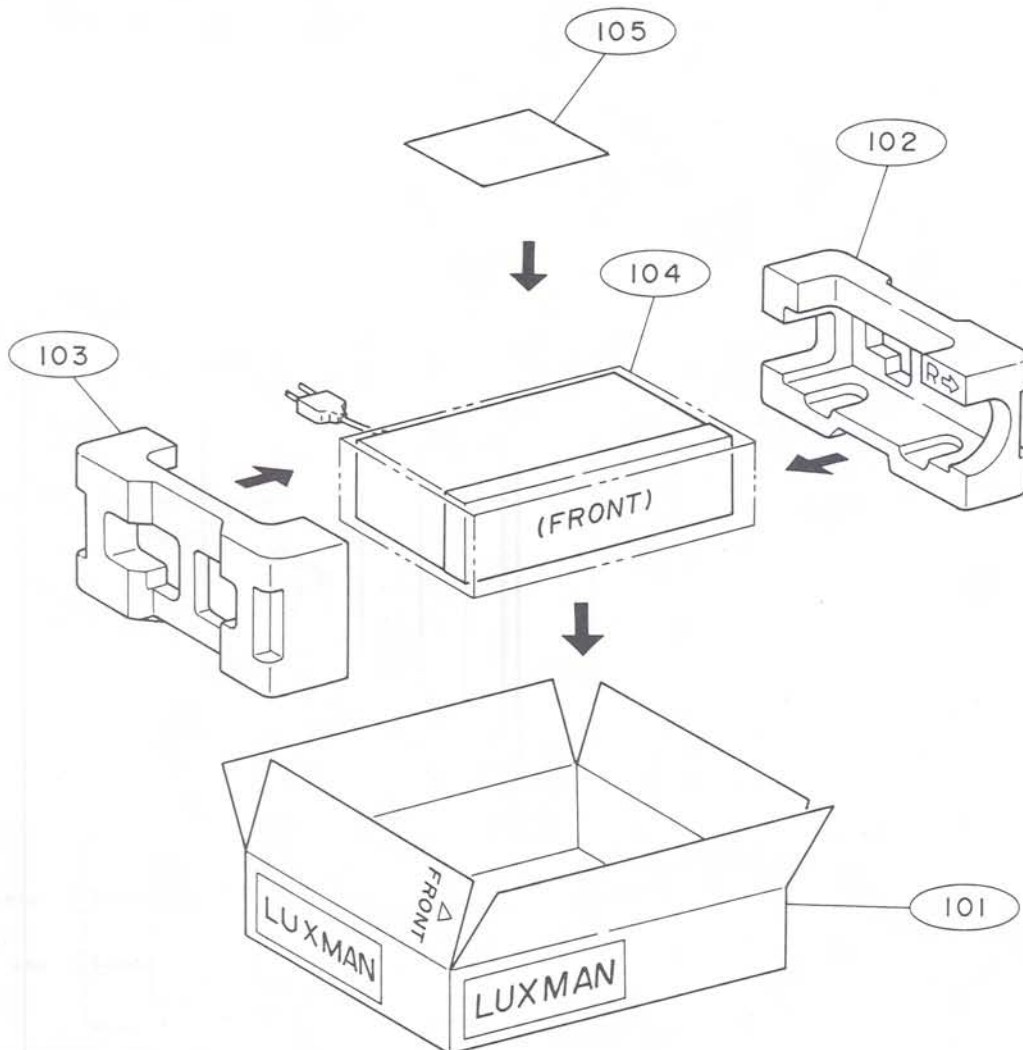

Cabinet Assembly Parts List

Note: The parts without part number are not supplied.

Symbol No.	Index	Part No.	Description			Symbol No.	Index	Part No.	Description		
1	2-B	15E08101S01	Cabinet, Top								
2		03E04702S01	Screw, Taptite (M4 x 8)								
3		03E04702S04	Screw, Taptite (M3 x 8)								
4	3-A	64E08104S01	Assy., Panel, Front								
5	3-A	03E04522S01	Screw, Taptite (M3 x 8)								
6	4-A	36E04673S01	Knob, Power								
7	5-A	36E08108S01	Knob, Volume Control/- dB								
8	5-B	36E08109S01	Knob, Bass /Treble/Balance/ Input Selector								
10		03E04701S01	Screw, Taptite (M3 x 8)								
11		05E04709S01	Rivet, Nylon								
12		03E04705S01	Screw, F- Lock (M3 x 6)								
13	4-C	36E04672S01	Knob, CD Straight								
14	1-D	02E06181S01	Nut, Flange (M4)								
16	3-D	03E04702S02	Screw, Taptite (M4 x 10)								
17		75E04521S01	Foot, Front								
18		03E04702S05	Screw, Taptite (M4 x 12)								
19		75E04678S01	Foot, Back								
20	3-D	07E08265S01	Holder								
23	4-E	03E04702S04	Screw, Taptite (M3 x 8)								
24	3-F	03E04707S01	Screw, Taptite (M3 x 10)								
25	3-F	03E04702S04	Screw, Taptite (M3 x 8)								
26	2-F	07E08283S01	Holder								
● 27	1-F	15E08266S01	Panel, Back								
○ 27	1-F	15E08267S01	Panel, Back								
28	1-F	43E04688S01	Bushing, Cord								
30		04E08111S01	Washer, Toothed (M3)								
31	1-G	29E04683S01	Lug								
32	2-G	03E04706S01	Screw, (M3 x 17)								

Note ● : For West Germany model only (AD)

○ : For General Foreign model only (EK)

Others Common

Exploded View (Cassette Deck)

1

2

3

4

5

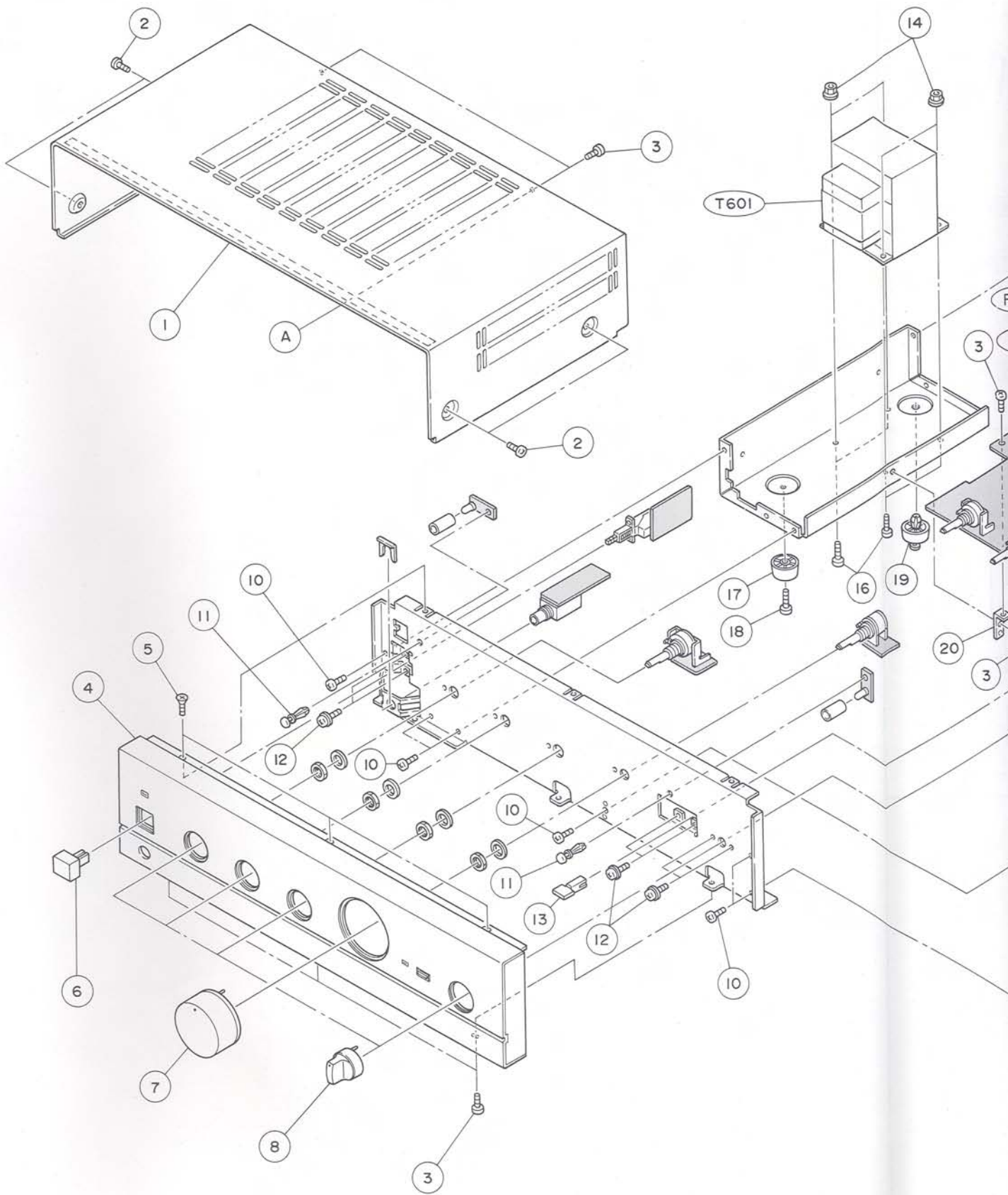

A

B - 23 -

C

D

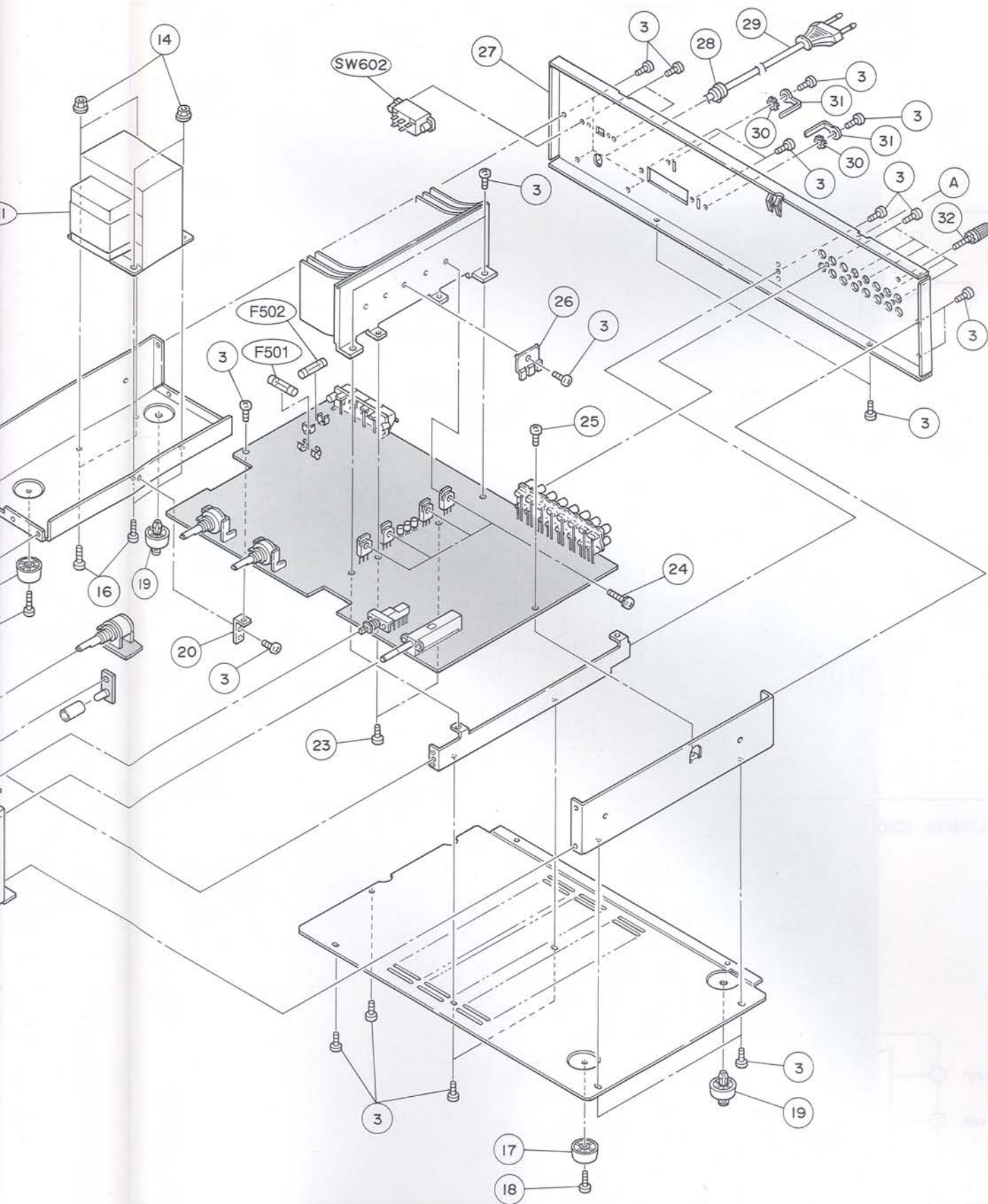

D

E

F

G

H

Semi-Conductor Lead Identifications

M5220L : IC101

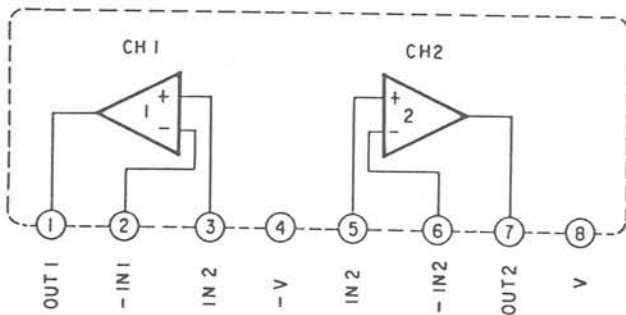
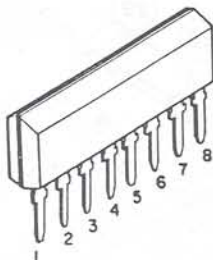

BA4558HT : IC201

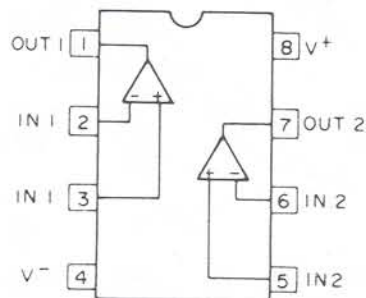
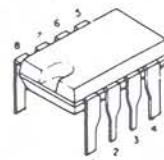

STK3042M-III : IC301

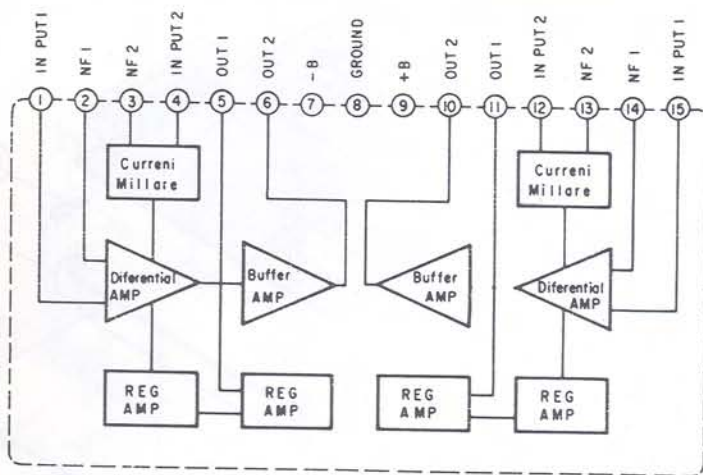
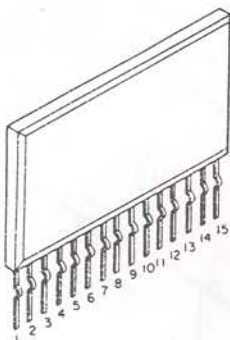

L78M15 : IC501

