

LUXMAN

SQ202

SERVICE MANUAL

CIRCUIT DESCRIPTION

The SQ202 is constituted by such circuits as equalizer, microphone amplifier, intermediate amplifier, tone control, filter, meter, power source and main amplifier etc. Almost all of these circuits are attached to the PCB's, and for easy understanding each PCB is explained as follows:

PB 931

This is the circuit to equalize the input signals from phono 1 and phono 2 according to RIAA response. Composition is of 3-stage NF type with NPN transistor 2SC1000. Usually in case of 2 channels at phono input the selection is made by switch under one equalizer amplifier, while on this model independent amplifiers are provided separately for phono 1 and phono 2 in order to evade various inconveniences which take place at the time of selection of switch - such as inductance noise, shock noise and adverse effects on tonal quality caused by shield wire, and the total 4 circuits for right and left channels are incorporated.

PB 933

This is an amplifier of flat response exclusively for microphone. Composition is made by 4 NPN transistor 2SC1000 (2 each for right and left channel, Q1Q3, Q2Q4). The input jacks (J1 J2) and mic. level setters (VR7A and VR7B) are directly attached to this board. The mic. signals fed through these jacks can be mixed for reproduction with these through other input channels such as phono, aux etc.

PB 932a PB 932b

These 2 PCB's are assembled provided with the switches (S1 S5) for selection of input sources (phono 1, phono 2, aux 1, aux 2, aux 3) and buffer for aux (emitter-follower circuits Q17 Q18).

PB 934

The 3-stage NF type intermediate amplifier composed by 2SC1000 (Q19 Q21 Q23 and Q20 Q22 Q24), and the emitter-follower which plays the role of buffer in case the attenuator is switched on (Q25 Q26), are assembled and connected to the filter circuit board PB936 through the connector. When the attenuator is switched on the signals go through only the emitter-follower bypassing the intermediate amplifier, while when switched off the emitter-follower remains idle.

PB 935

On this PCB assembled are the tone control circuit and the ripple filter circuit for the mains source in the pre-amplifier section. Tone control function is given by 2 transistor per channel (Q27 Q29, Q28 Q30) on the signals taken out at low impedance from the intermediate amplifier or emitter-follower on PB 934.

Toiloring is made under LUX's exclusive circuit composition. The variation of tonal quality is made at bass range by VR3 and treble by VR4. The turn-over and roll-off frequencies can be selected among 150Hz, 300Hz and 600Hz at bass and 1.5kHz, 3kHz and 6kHz at treble by the switches (S12 and S13) fixed to this board.

When both of switches (S12 S13) are at the "defeat" position the signals are shut out at the tone control circuit and fed direct to the following stages. The ripple filter circuit composed by Q59 which causes smoothing effect on the DC voltage from D1 equivalent to several thousand MF, and yet has the nature of quick start provides the power sources to those stages at pre-amplifier section.

PB 936a PB 936b

The filter circuit, loudness circuit and attenuator circuit are assembled on these 2 boards together with the on/off switches for these circuits. The filter circuit is of NF type with sharp response 12 dB/oct. An individual amplifier is arranged for low cut filter 30Hz (Q33 Q34) 80Hz (Q31 Q32) and high cut filter 5kHz (Q35 Q36) 9kHz (Q37 Q38), and total 8 amplifiers are incorporated for right and left channels. These filter circuits do not function at the flat position just like the tone controls and intermediate amplifier.

PB 938

The circuit ingredients (D11, D12, D13, D14 etc.) to drive VU meter and step-up amplifier (Q39 Q40) which boosts the signals from pre out to such level as to drive the meter. The interchangeability among 3 positions is available on the meter indication by the switches S22A S22B at the rear panel, namely, indication on PRE OUT level (VU), on full power (0 dB) at power amplifier section, and on the same under attenuation (-14 dB).

PB 937A

This board is equipped with the smoothing capacitors for the bridge rectifier circuits (D3 D4 D5 D6) composed by the main amplifier power supply diode V05, the full wave rectifier circuit (D1) by pre-amplifier circuit diode IS1850,

and full wave rectifier (D2) by 2 illumination power source diodes IS1850. The positive side of the coupling connector with the main amplifier board PB930A is also attached.

PB930A

The main amplifier is composed by the power transistors 2SD218 Q55 Q56 (NPN) 2SA649 Q57 Q58 (PNP) fixed to the heat-sink and the various components fixed on the PB930. The circuit configuration is direct coupled 2-stage differential driving pure complementary system. This PB930 is composed by the 1st stage differential driving amplifier XA495C Q43Q45 Q44Q46, the 2nd stage 2SC959 Q47Q49 Q48Q50, driver stage Q51Q52 2SC959 Q53Q54 2SA606, and resistors and capacitors, which is connected to the power source board PB937A through 6P connector. The heat-sink is fixed direct to the rear panel.

PB931 BOARD

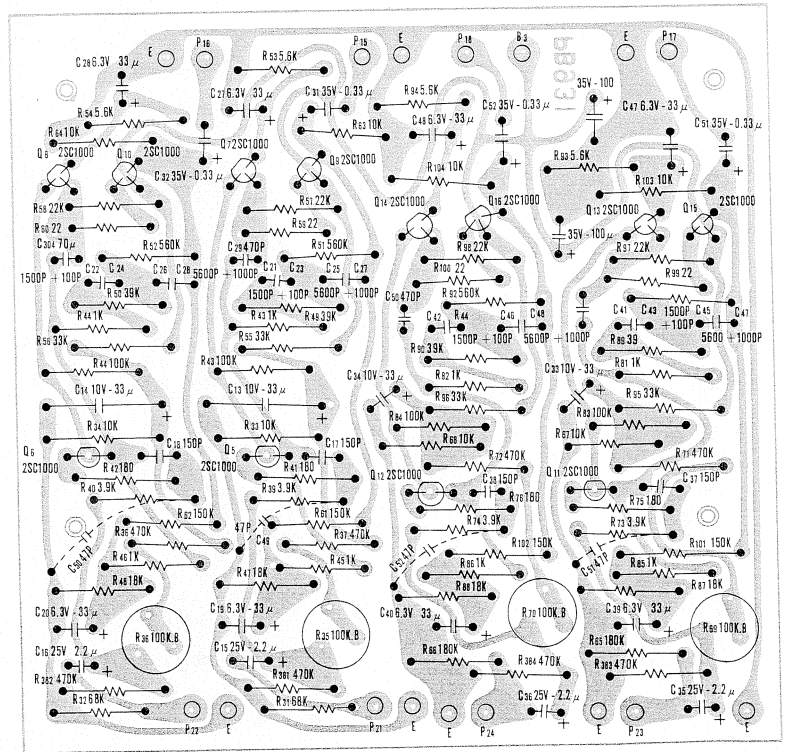

PB932a BOARD

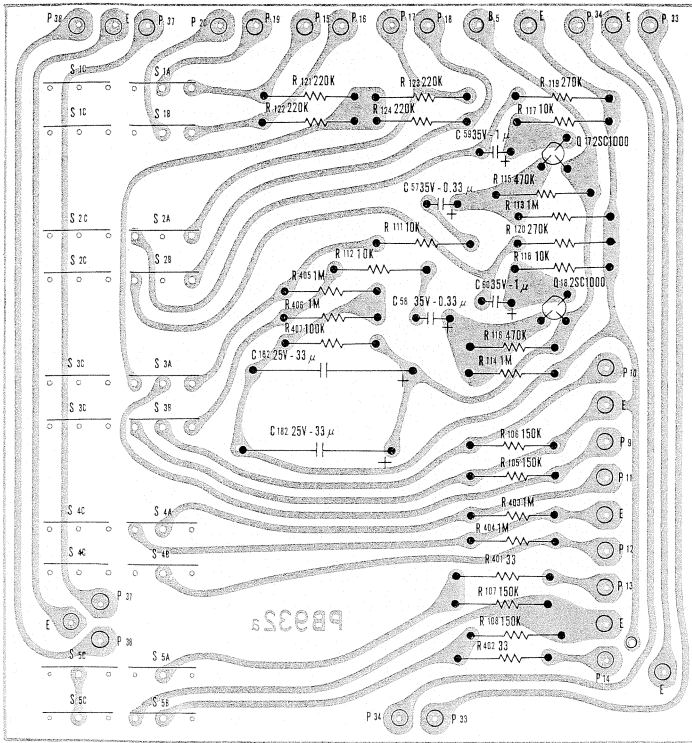

PB932b BOARD

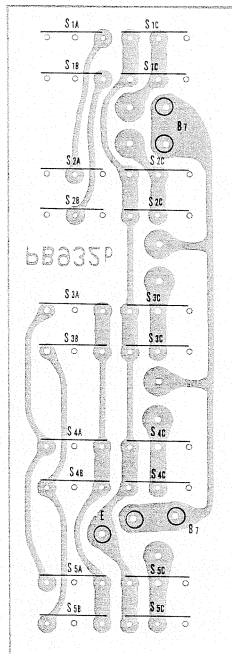

PB933 BOARD

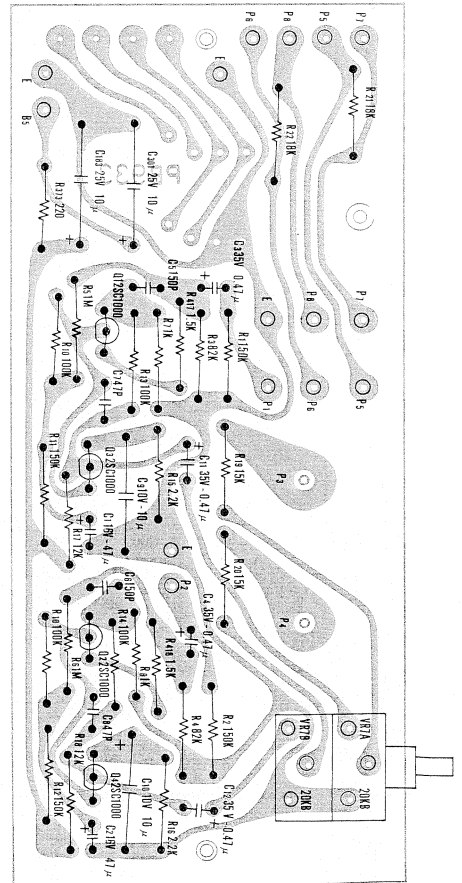

PB935 BOARD

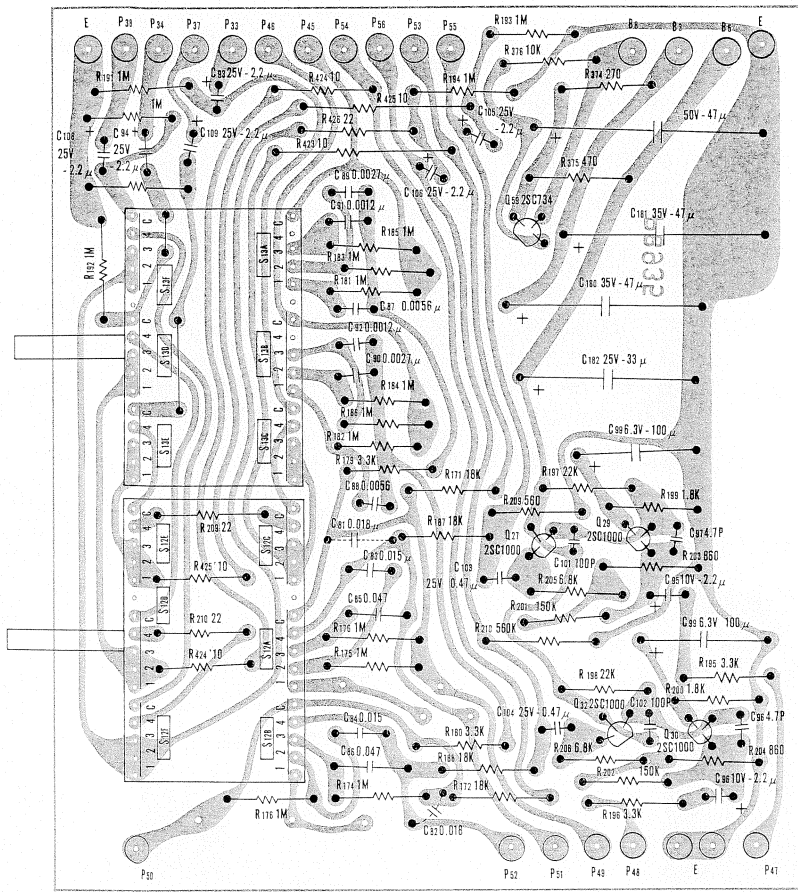

PB930A BOARD

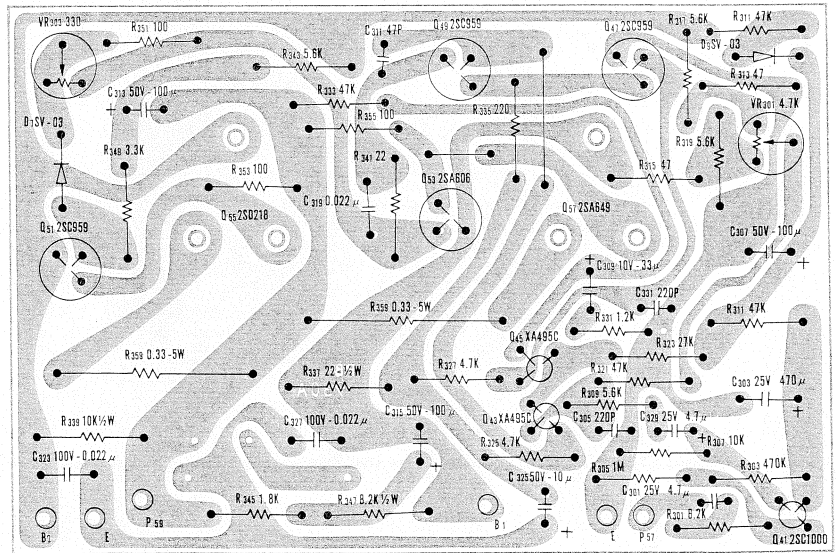

PB934 BOARD

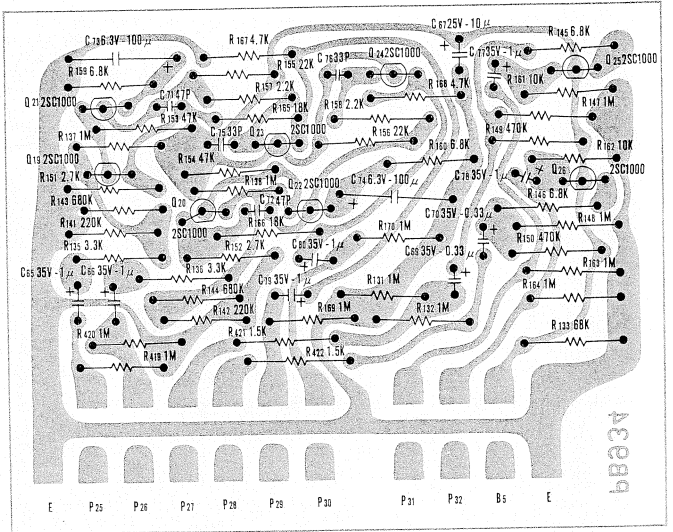

PB936a BOARD

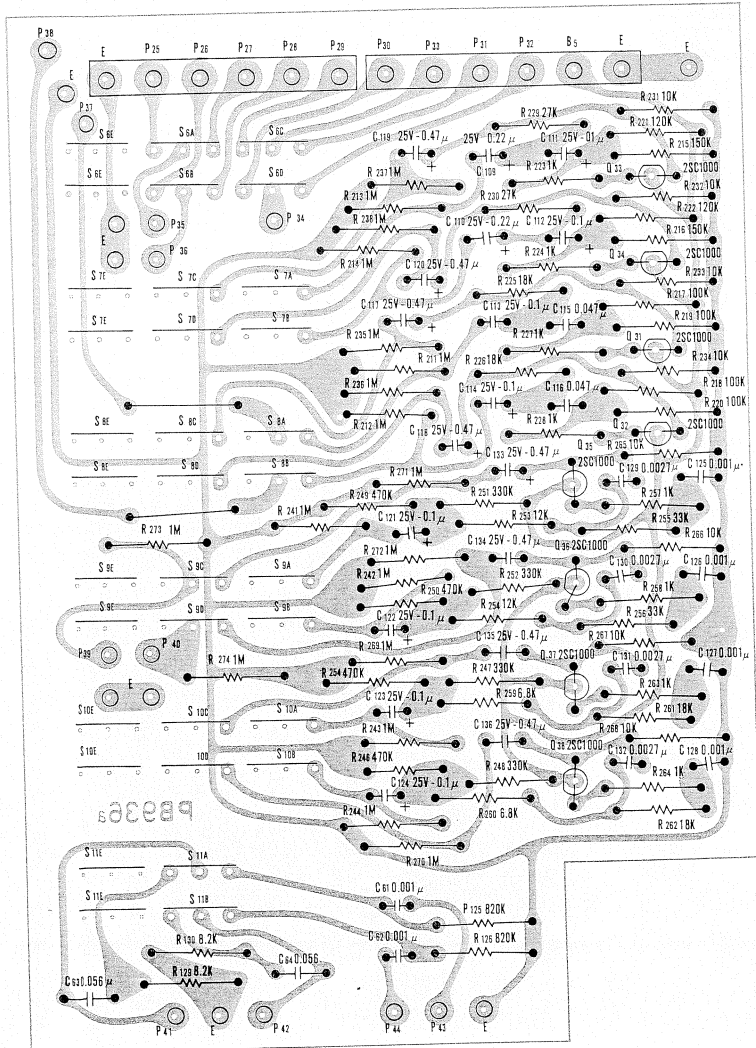

PB936b BOARD

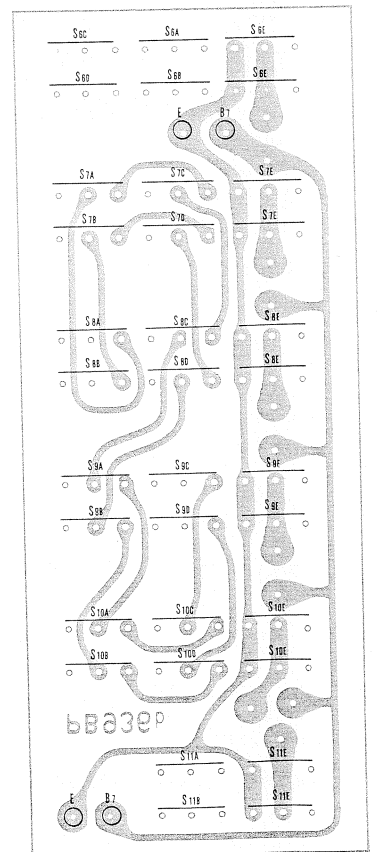

PB937A BOARD

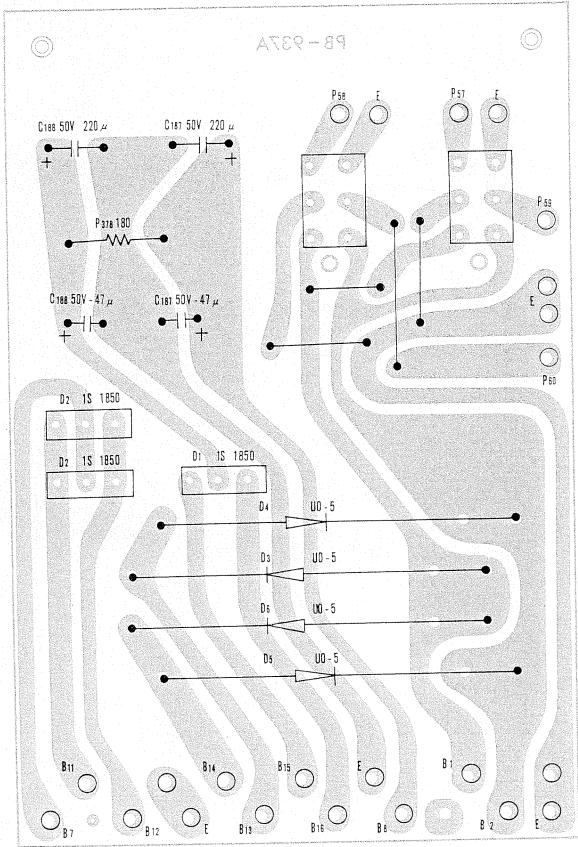

PB938 BOARD

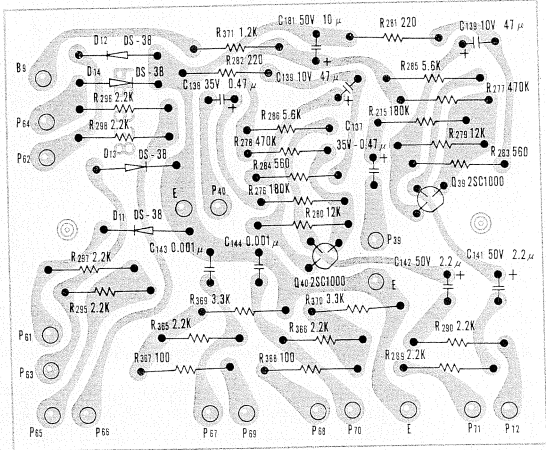

CABINET DISASSEMBLY

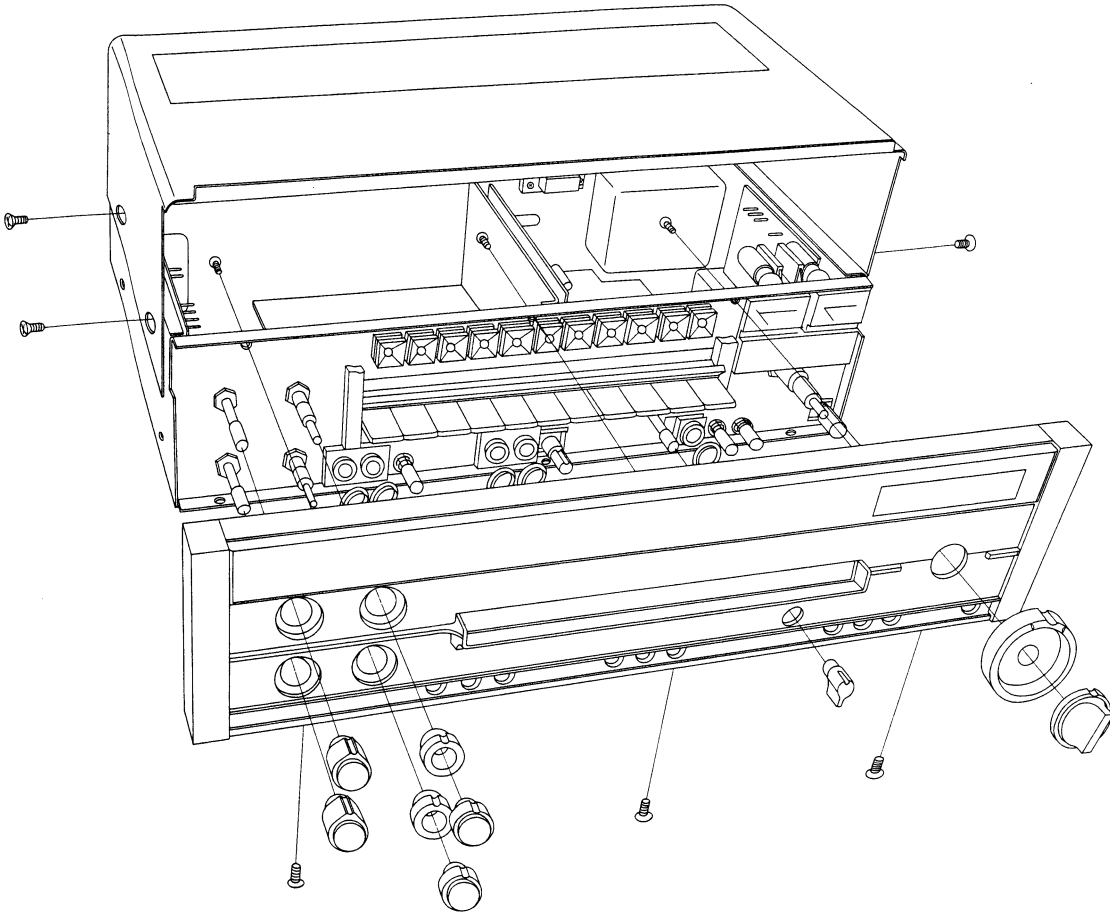

CHASSIS LAYOUT (TOP)

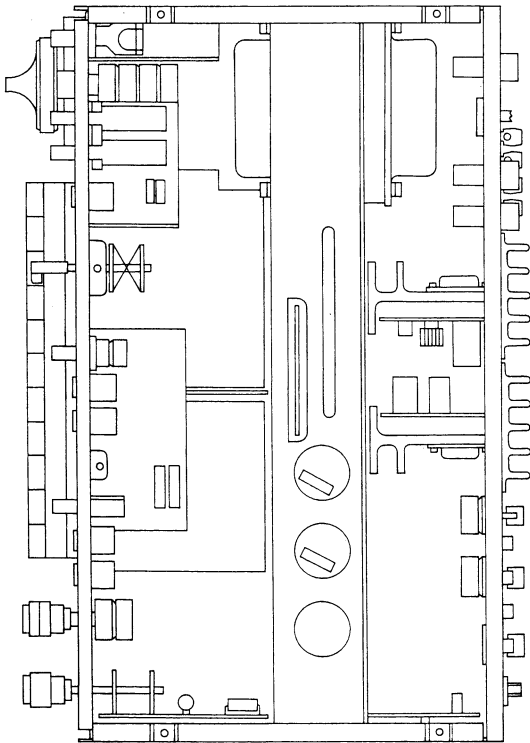

CHASSIS LAYOUT (BOTTOM)

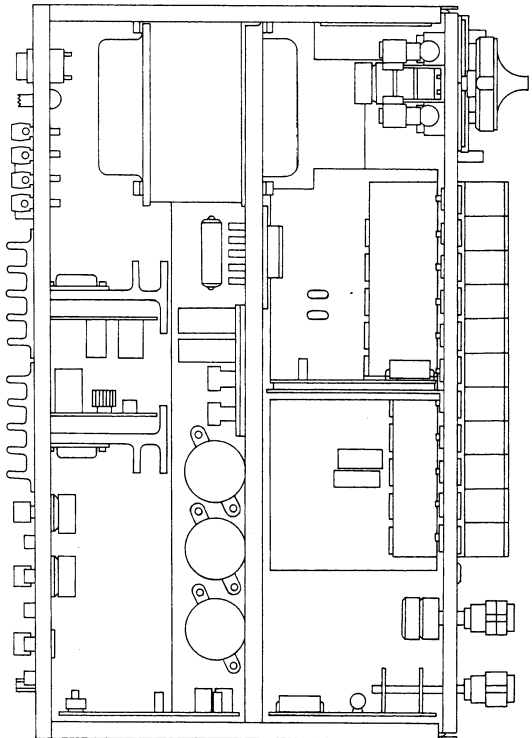

PARTS LIST

MECHANICAL

1	Sub panel	1
2	Side plate	1 pair
3	Base plate	1
4	Center flange	1
5	Back panel	1
6	Meter lamp holder	1
7	Power switch shield metal	1
8	Fixing metal for microphone jack	2
9	Speaker switch shield metal	1
10	Light shield metal for meter	1
11	Fixing metal for side board --- wood	1 pair
12	Push button rail	1
13	Push button holder	1
14	Bonnet	1
15	Power board holder	1
16	Indicator lamp holder	11
17	Shield bracket	1
18	Swan base socket	4
19	PCD mounting stand	4
20	Fixing metal for push button	1
21	Jack short plate	1
22	Fixing metal for phone jack	1
23	AM frontend fixing stand	2
24	Rubber for meter (black)	1
25	Rubber for shield bracket	1
26	Soft tape	1
27	Fixing plate for power board	1
28	Washer for microphone jack	2
29	Fixing metal for power board	1

DESIGNING/OUTER APPEARANCE

30	Front panel	1
31	Side board --- wood	1 pair
32	Outer axis volume knob, mold	1
33	Volume knob, mold	1
34	Smoked acrylic plate	1
35	Outer axis tone control knob, mold	2
36	Inner axis tone control knob, mold	2
37	Cap for tone control knob	4
38	Pipe for tone control knob	4
39	Slope switch knob, mold	2
40	Mode switch knob	1
41	Push button for selector switch	11
42	Push button for speak switch	3
43	Escutcheon for push button (A)	1
44	" " (B)	1
45	" " (C)	1
46	Level set knob	1
47	Push button for power switch	1
48	Panel clamping stand	3
49	Black color paper for knob	1
50	Styro-form	2
51	Jack Sleeve, rubber	5
52	Rubber base	4
53	Metal stand	4
54	Metal for volume knob	1

OVERALL COMPONENTS

55	Power transformer	P-1682E(V)	1
56	Power switch	UEH 12BF	1
57	Speaker switch	2PS-13	1
58	Stereo phone jack	SJ7702	3
59	Variable resistor	100K Ω Bct, 100K Ω A, Cct 2-gang dual type	1
60	"	100K Ω B	
61	"	2-gang friction type	1
62	VU meter	50K Ω B	
63	Mode selector switch	2-gang friction type	1
64	Indicator lamp	F445	1
65	"	12V 1.5W	5
66	Block electrolytic condenser	12V 75mA	11
67	"	10,000 μ f 16wv	1
68	Terminal board base	3,300 μ f 63wv	2
69	Cement film resistor	15P	1
70	Fixed resistor	5K Ω 5w	2
71	"	680 Ω 1W \pm 5%	2
72	Bushing --- cord	15K Ω 1/4w \pm 10%	2
73	Voltage selector socket	Bu 4801	7
74	Output terminal board	9208 9209	1 pair
75	Input pin jack terminal board	4P square push terminal	2
76	Input pin jack terminal board	10P non short type	1
77	Variable resistor	8P	1
78	Small selector switch	100K Ω B type 24 ϕ	
79	Slide switch	2-gang click	2
80	"	4 way 3 contact	1
81	Tape connector	2 way 3 contact	1
82	GND terminals	2 way 2 contact	1
83	AC outlet	DIN	1
84	Fuse holder	VB2 VN2 VW2	1 set
85	Fuse	SE6407	3
86	AC input connector	S-N 2052	3
87	Power cord	5A	4
88	Speaker cord	S-I 6405	1
89	Selector disc		1
90	GND lug		6m
91	GND lug	3 ϕ B-5	3
92	Wires	4 ϕ B-6	1
93	Short pin plug	UL, AWG22 AWG18	
94	Cord clamper	US type	4
95	Fixed resistor		4
96	"	100K Ω 1/4w	2
97	Oil tubular condenser	47K Ω 1/4w	2
98	Fixed resistor	0.047 μ F 450V AC	2
99	"	150K Ω 1/4w	4
100	"	33K	2
101	Electrolytic condenser	12K	2
102	Ceramic condenser	1 μ F 50v non-polar	2
103	Fixed resistor	0.04 μ F 50V	2
104	Ceramic condenser	10 Ω 1w \pm 5%	2
105	"	0.006 μ F 50V	1
106	Film condenser	47pF 50V \pm 10%	4
		1000pF 50V \pm 10%	4

PB 931				158	Electrolytic condenser	10 μ F 25V	2
107	Printed circuit board	PB931	1	159	"	10 μ F 10V	2
108	Transistor	2SC1000	12	160	"	4.7 μ F 10V	2
109	Semi-fixed resistor	100K Ω B type 10 ϕ	4	161	Solid tantalum condenser	0.45 μ F 35V	4
110	Electrolytic condenser	33 μ F 10v	10	162	Ceramic condenser	150pF 50V	2
111	"	100 μ F 35V	2	163	"	47pF 50V	2
112	"	33 μ F 10V	2	164	Fixed resistor	150K Ω 1/4 \pm 10%	4
113	Solid tantalum condenser	2.2 μ F 25V \pm 20%	4	165	"	1M Ω "	2
114	"	0.33 μ F 35V +40% -20%	4	166	"	100K Ω "	2
115	Polyester film condenser	0.0056 μ F 50V \pm 10%	4	167	"	68K Ω "	4
116	"	0.0015 μ F 50V \pm 10%	4	168	"	18K Ω "	2
117	Styrol condenser	470pF 50V	4	169	"	15K Ω "	2
118	Ceramic condenser	150pF 50V	4	170	"	12K Ω "	2
119	"	100pF 50V	4	171	"	2.2K Ω "	2
120	Fixed resistor	22 Ω 1/4W \pm 10%	4	172	"	1.5K Ω "	2
121	"	560K Ω 1/4W \pm 10%	4	173	"	220 Ω "	1
122	"	470K Ω "	8	174	"	82 Ω "	2
123	"	180K Ω "	2	175	Low noise fixed resistor	100K Ω 1/4W \pm 10%	2
124	"	150K Ω "	4	176	"	1K Ω "	2
125	"	68K Ω "	2	177	Lug grommet	I type	2
126	"	39K Ω "	4	178	Push button switch	6 button 6 way (5) 4 way (1)	1
127	"	33K Ω "	4	179	PB connector	6P	2 pairs
128	"	22K Ω "	4	PB934 PB936a PB936b			
129	"	18K Ω "	4	180	Printed circuit board	PB934	1
130	"	10K Ω "	8	181	"	PB936a	1
131	"	5.6K Ω "	4	182	"	PB936b	1
132	"	3.9K Ω "	4	183	Transistor	2SC1000	16
133	"	1K Ω "	4	184	Ceramic condenser	0.001 μ F 50v \pm 10%	2
134	"	180K Ω "	4	185	"	0.0027 μ F "	4
135	Low noise fixed resistor	100K Ω 1/4W \pm 10%	4	186	"	0.001 μ F "	4
136	"	1K Ω "	4	187	Aluminum solid electrolytic condenser	0.47 μ F 25V \pm 20%	8
137	Push button switch	5 button 4 way coupled shorting type	1	188	"	0.33 μ F "	2
PB 932a PB 932b				189	"	0.22 μ F "	2
138	Printed circuit board	PB932a	1	190	"	0.1 μ F "	8
139	"	PB932b	1	191	Solid tantalum condenser	1 μ F 35V \pm 20%	6
140	Transistor	2SC 1000	2	192	Polyester film condenser	0.0056 μ F	2
141	Electrolytic condenser	33 μ F 25V	2	193	"	0.047 μ F	2
142	Solid tantalum condenser	1 μ F 35V	2	194	Ceramic condenser	47pF 50V	2
143	"	0.33 μ F 35V	2	195	"	33pF 50V	2
144	Fixed resistor	1M Ω 1/4W \pm 10%	6	196	Electrolytic condenser	100 μ F 6.3V	2
145	"	470K Ω "	2	197	"	10 μ F 25V	1
146	"	220K Ω "	4	198	Fixed resistor	1M Ω 1/4W \pm 10%	28
147	"	150K Ω "	4	199	"	470K Ω "	6
148	"	33 Ω "	2	200	"	270K Ω "	2
149	"	100K Ω "	1	201	"	330K Ω "	4
150	"	10K Ω "	4	202	"	100K Ω "	4
151	"	270K Ω "	2	203	"	560K Ω "	2
152	"			204	"	150K Ω "	2
PB 933				205	"	120K Ω "	2
153	Printed circuit board	PB933	1	206	"	47K Ω "	2
154	Jack with switch	Microphone, mono	2	207	"	33K Ω "	2
155	Volume	16 ϕ 20K ~ B coupled	1	208	"	27K Ω "	2
156	Push button switch	Monitor, 2 way	1	209	"	22K Ω "	2
157	Transistor	2SC 1000	4	210	"	18K Ω "	6
				211	"	12K Ω "	2

212	"	10K Ω	"	10
213	"	8.2K Ω	"	2
214	"	6.8K Ω	"	6
215	"	2.7K Ω	"	2
216	"	4.7K Ω	"	2
217	"	3.3K Ω	"	2
218	"	2.2K Ω	"	2
219	"	1.5K Ω	"	2
220	"	1K Ω	"	8
221	"	820K Ω	"	2
222	"	68K Ω	"	1
223	"	15K Ω	"	2
224	"	680K Ω	"	2
225	"	220K Ω	"	2

PB935

226	Printed circuit board	PB935		1
227	Selector switch	2 stage 6 way 4 contact		2
228	Transistor	2SC1000		4
229	"	2SC 734Y		1
230	Electrolytic condenser	47 μ F 50V		1
231	"	33 μ F 25V		1
232	"	47 μ F 35V		2
233	"	100 μ F 6.3V		2
234	Solid tantalum condenser	2.2 μ F 25V		8
235	"	0.47 μ F 35V		2
236	Film condenser	0.0012 μ F 50V \pm 10%		2
237	"	0.00 27 μ F "		2
238	"	0.0056 μ F "		2
239	"	0.015 μ F "		2
240	Polyester film condenser	0.018 μ F "		2
241	"	0.047 μ F "		2
242	Fixed resistor	470 Ω 1/4W \pm 10%		1
243	"	270 Ω		1
244	"	1M Ω		16
245	"	560K Ω		2
246	"	150K Ω		2
247	"	22K Ω		2
248	"	18K Ω		4
249	"	10K Ω		1
250	"	6.8K Ω		2
251	"	3.3K Ω		4
252	"	1.8K Ω		4
253	"	820 Ω		2
254	"	820K Ω		2
255	"	22 Ω		2
256	"	15 Ω		2
257	"	10 Ω		4
258	Ceramic condenser	100pF 50V		2
259	"	4.7pF 50V		2
260	Fixed resistor	1M Ω 1/4W \pm 10%		2
261	"	470K Ω		2
262	"	47K Ω		6
263	"	27K Ω		2
264	"	10K Ω		2
265	"	5.6K Ω		8
266	"	4.7K Ω		4
267	"	3.3K Ω		2

268	"	1.8K Ω	"	2
269	"	1.2K Ω	"	2
270	"	470 Ω	"	2
271	"	220 Ω	"	2
272	"	100 Ω	"	6
273	"	47 Ω	"	4
274	"	22 Ω	"	2
275	"	8.2 Ω	"	2
276	"	10K Ω 1/2W \pm 5%		2
277	"	8.2K Ω	"	2
278	"	22K	"	2
279	Square fixed resistor	0.33 Ω 5W		4

PB930A

280	Printed circuit board	PB930A		2
281	Heat sink	120mm		2
282	Transistor	VCEO 60V , XA495C		4
283	"	M rank 2SD 218		2
284	"	" 2SA 649		2
285	"	L rank 2SC 959		1
286	"	" 2SA 606		2
287	"	2SC 1000GR		2
288	Varistor	SV - 03		2
289	Power transistor accessory	Mica, Screw, Spring washer		4 pairs
290	Power transistor socket	S2 - 110B		4
291	Semi fixed resistor	4.7K Ω Btype 10 ϕ		2
292	"	330 Ω "		2
293	Small radiator	for TD - 5		8
295	Driver transistor pad	"		8
295	Electrolytic condenser	470 μ F 25V		2
296	"	100 μ F 50V		6
297	"	33 μ F 10V		2
298	"	10 μ F 63V		2
299	Polyester film condenser	0.022 μ F 100V		4
300	"	0.022 μ F 50V		2
301	Solid tantalum condenser	4.7 μ F 25V \pm 20%		4
302	Ceramic condenser	220pF 100V \pm 10%		4
303	"	47pF 100V		2
304	"	100pF 100V		2
305	Comb. line connector	Receptacle housing C152304		2
306	"	Direct pin 152307-1		12
307	"	Receptacle socket 61064-1		12

PB937A

308	Printed circuit board	PB937A		1
309	Diode	2.8A - 300V \sim , U05		4
310	"	1S - 1850		3
311	Electrolytic condenser	220 μ F 50V		2
312	"	47 μ F 50V		2
313	Fixed resistor	180 Ω 1/4W \pm 10%		1

PB938

314	Printed circuit board	PB938		1
315	Transistor	2SC 1000GR		2

316	Electrolytic condenser	2.2 μ F 50V	2
317	Solid tantalum condenser	0.47 μ F 35V	2
318	Silicon diode	DS38B	4
319	Electrolytic condenser	10 μ F 50V	1
320	"	47 μ F 10V	2
321	Ceramic condenser	0.001 μ F 50V	2
322	Fixed resistor	470K Ω 1/4W \pm 10%	2
323	"	180K Ω "	2
324	"	12K Ω "	2
325	"	5.6K Ω "	2
326	"	3.3K Ω "	2
327	"	2.2K Ω "	8
328	"	1.2K Ω "	1
329	"	560 Ω "	2
330	"	220 Ω "	2
331	"	100 Ω "	2
332	PCB terminal	for PB931	17
333	"	for PB933	19
334	"	for PB935	23
335	"	for PB938	20

SCREWS WASHERS & NUTS

336	outlet mounting	3mm ϕ 8mm long screw	6
337	"	3mm ϕ washer	6
338	"	3mm ϕ square nut	6
339	AC input connector mounting	3mm ϕ 8mm long screw	2
340	"	3mm ϕ washer	2
341	"	3mm ϕ nut	2
342	Speaker terminal board mounting	2mm ϕ 8mm long screw	8
343	"	2mm ϕ washer	8
344	"	2mm ϕ nut	8
345	Meter slide switch mounting	2.6mm ϕ 4mm long screw	2
346	Pre-main separator slide switch mounting	2.6 mm ϕ 4mm long screw	2
347	Ventillation plate mounting	3mm ϕ 6 mm long screw	8
348	Input terminal mounting	3mm ϕ 8mm long screw	6
349	"	3mm ϕ washer (spring)	5
350	"	3mm ϕ washer (inner clip)	1
351	"	3mm ϕ nut	6
352	DIN connector mounting	3mm ϕ 6mm long screw	2
353	"	3mm ϕ washer	2
354	"	3mm ϕ nut	2
355	GND terminal mounting	3mm ϕ washer	1
356	"	3mm ϕ nut	1
357	Side board (wood) mounting - back panel	3mm ϕ 6mm long screw	4
358	"	3mm ϕ washer	4
359	Condenser mounting	3mm ϕ 6mm long screw	6
360	Power board clamp panel mounting	3mm ϕ 6mm long screw	2
361	Power board clamp metal mounting	3mm ϕ 6mm long screw	2

362	Power board mounting	3mm ϕ 6mm long screw	2
363	Voltage selector connector mounting	3mm ϕ 10mm long screw	2
364	Side board (wood) mounting - center flame	4mm ϕ 6mm long screw	8
365	Power trans mounting	5mm ϕ washer	4
366	"	5mm ϕ nut	4
367	Wire clamp metal mounting	3mm ϕ 6mm long screw	4
368	15T terminal mounting	3mm ϕ 8mm long screw	2
369	Power board clamp metal mounting	3mm ϕ washer	2
370	Side board mounting - sub panel	3mm ϕ 6 mm long screw	6
371	"	3mm ϕ washer	6
372	Microphone jack clamp panel mounting	3mm ϕ 6mm long screw	4
373	Headphone jack clamp panel mounting	3mm ϕ 6mm long screw	1
374	Monitor switch mounting	2.6mm ϕ 4mm long screw	2
375	"	2.6mm ϕ washer	2
376	Speaker switch mounting	2.6mm ϕ 6mm long screw	2
377	"	2.6mm ϕ nut	4
378	Power switch mounting	3mm ϕ 6mm long screw	2
379	"	3mm ϕ washer	2
380	Meter mounting	2mm ϕ nut	4
381	"	2mm ϕ washer	4
382	Light shield metal for meter mounting	2mm ϕ nut	2
383	Push button switch mounting	2.6mm ϕ 6mm long screw	4
384	"	2.6mm ϕ nut	8
385	Push button switch clamp metal mounting	3mm ϕ 6mm long screw	2
386	Shield bracket mounting	3mm ϕ 6mm long screw	2
387	"	3mm ϕ washer	2
388	Meter lamp holder mounting	3mm ϕ 6mm long screw	1
389	"	3mm ϕ washer	1
390	GND lug mounting	3mm ϕ 6mm long screw	1
391	Speaker switch shield metal mounting	3mm ϕ 6mm long screw	2
392	"	3mm ϕ washer	2
393	PCB clamp stand mounting	2.6mm ϕ 6mm long screw	4
394	Equalizer board mounting	2.6mm ϕ nut	4
395	Power transformer mounting	5mm ϕ 10mm long screw	2
396	"	5mm ϕ washer	2
397	"	5mm ϕ washer (spring)	2
398	"	5mm ϕ nut	2
399	Meter board clamp stand mounting	3mm ϕ 6mm long screw	2
400	Meter board mounting	3mm ϕ nut	2

401	Power switch shield metal mounting	3mm ϕ 6mm long screw	2
402	"	3mm ϕ washer	2
403	Side board (wood) mounting	3mm ϕ 6mm long screw	6
404	Side board (wood) clamp metal mounting	3mm ϕ 6mm long screw (pan head)	2
405	"	3mm ϕ 6mm long screw (cheese head)	2
406	"	3mm ϕ washer	2
407	Smoked acrylic plate mounting	3mm ϕ 8mm long screw	3
408	"	3mm ϕ washer	3
409	Front panel mounting - sub panel	3mm ϕ 6mm long screw (pan head)	3
410	"	3mm ϕ 6mm long screw (cheese head)	3
411	"	3mm ϕ washer	3
412	Push button escutcheon mounting	3mm ϕ 6mm long screw	6
413	"	3mm ϕ washer	6
414	"	2mm ϕ speed nut	5
415	Base plate mounting	3mm ϕ 6mm long screw	6
416	Rubber base mounting	4mm ϕ 8mm long screw	4
417	Bonnet mounting	4mm ϕ 10mm long screw	4
418	"	4mm ϕ washer	4

SPECIFICATIONS

■ Main Amplifier Section

Output	70W/70W RMS (8Ω both channels driven) 80W/80W RMS (8Ω single channel driven) 100W/100W RMS (4Ω single channel driven)
THD	below 0.04% (8Ω, 1KHz) below 0.05% (4Ω, 1KHz)
Intermodulation Distortion	below 0.05% (8Ω 70Hz: 7KHz = 4:1)
Power Band width	5~50,000Hz (within -3dB)
Frequency Response	10~60,000Hz (within -1dB)
Input Sensitivity	700mV (8Ω, 50W) with level control
Input Impedance	about 100KΩ
Cross-Talk	66dB
Residual Noise	about 1mV
Damping Factor	35 (8Ω) 70(16Ω)
Accessories	Output indication meter Main-remote speaker selector Headphone jack Mains voltage selector Extra mains outlet

■ Others

Transistors	2SD218 (2) 2SA649 (2) 2SC959 (6) 2SA606 (2) 2SC1000 (43) XA495C (4)
Diode	U05 (4) IS1850 (3) DS38B (4)
Varistor	SV-03 (4)
Power Consumption	270W (8Ω), max. output, both channel driven)
Mains Voltage	100, 117, 220, 240V
Dimensions	480mm (W) X 280mm (D) X 165mm (H)
Weight	12.5 kg

■ Pre-Amplifier Section

Rated Output Voltage	Pre-out: 700mV Tape-out: 110mV
Max. Output Voltage	Approx. 5V
Output Impedance	Pre-out: Approx. 100Ω Tape-out: Approx. 100Ω
Frequency Response	20~70,000Hz (within -1dB)
THD	below 0.05% (AUX-1, 1KHz)
Input Sensitivity	Phono-1: 2mV Phono-2: 2mV Aux-1: 110mV Aux-2: 110mV (with level controller) Aux-3: 110mV Mic mix: 2.5mV Tape-in: 110mV

Input Impedance

Phono-1: 50KΩ
Phono-2: 30K, 50K,
100KΩ selectable

Aux-1: 100KΩ
Aux-2: 100KΩ
Aux-3: 100KΩ
Mic mix: 50KΩ

Permissible Input Voltage

Phono-1: 180mV
Phono-2: 180mV
Aux-1: 5V
Aux-2: over 5V
Aux-3: 5V

Ham Noise (S/N Ratio) (Pre Out: 700mV)

Phono-1: 66dB
Phono-2: 66dB
Aux-1: 80dB
Aux-2: 80dB
Aux-3: 80dB
Mic (mix with Aux-1): 66dB
(S/N ratio adjusted under IHF "A" curve)

Phono-1: 81dB
Phono-2: 81dB

Aux-1: 90dB
Aux-2: 90dB
Aux-3: 90dB

Mic (mix with Aux-1): 75dB
(Noise voltage VS input)

Phono-1: -120dB/V
Phono-2: -120dB/V
Aux-1: -110dB/V
Aux-2: -110dB/V
Aux-3: -110dB/V

Mic (mix with Aux-1): -118dB/V

Approx. 25μV

Residual Noise

Cross-talk

Phono: 66dB

Aux: 71dB

High Cut: 5KHz, 9KHz

Low Cut: 30Hz, 80Hz

Filter

Cutting slope:
-12dB/Oct

Loudness Control
(Adjustment at -18dB)

Attenuator

Accessories

50Hz: +8.5dB

10KHz: +7.5dB

-18dB

Tape monitor switch and terminals
Mode selector

Input impedance selector (Phono-2)

Input level setter (Aux-2)

DIN tape connector

Mic jack and level setter

CIRCUIT DIAGRAM

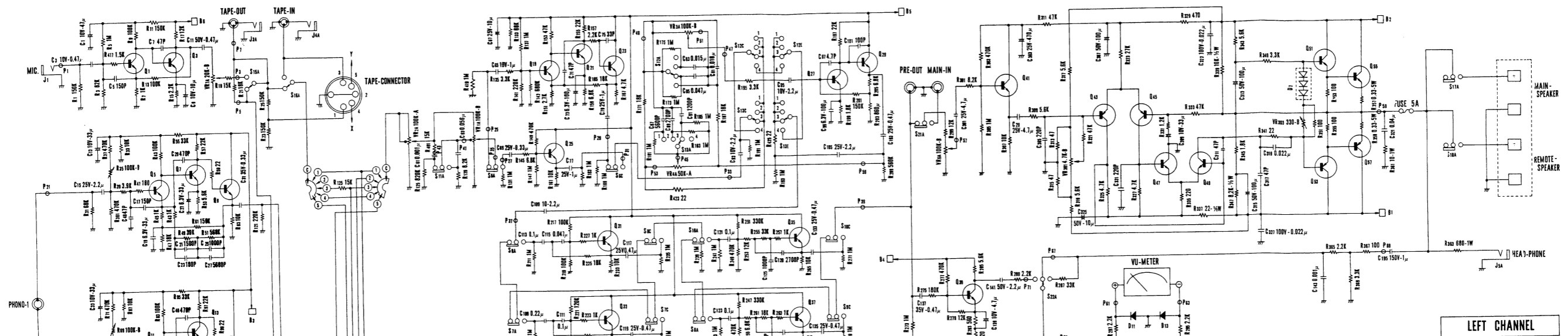

- S1A, S1B, S1C INPUT SELECTOR PHONO-1
- S2A, S2B, S2C INPUT SELECTOR PHONO-2
- S3A, S3B, S3C INPUT SELECTOR AUX-1
- S4A, S4B, S4C INPUT SELECTOR AUX-2
- S5A, S5B, S5C, S5D INPUT SELECTOR AUX-3
- S6A, S6B, S6C, S6D, S6E ATTENUATOR
- S7A, S7B, S7C, S7D, S7E LOW CUT 30-Hz
- S8A, S8B, S8C, S8D, S8E LOW CUT 90-Hz
- S9A, S9B, S9C, S9D, S9E HIGH CUT 5-KHz
- S10A, S10B, S10C, S10D, S10E HIGH CUT 5-KHz
- S11A, S11B, S11C LOUDNESS CONT.
- S12A, S12B, S12C, S12D, S12E, S12F BASS CONT. FREQ. SELECTOR
(1. 500Hz, 2. 300Hz, 3. 150Hz, 4. (DEFAULT))
- S13A, S13B, S13C, S13D, S13E, S13F TREBLE CONT. FREQ. SELECTOR
(1. 1.5KHz, 2. 3KHz, 3. 6KHz, 4. (DEFAULT))
- S14A, S14B, S14C, S14D MODE SELECTOR
(1. MONO L. 2. MONO R. 3. L+R. 4. STEREO. 5. REVERSE)
- S15A, S15B MICROPHONE MIX. SW.
- S16A, S16B MONITOR
- S17A, S17B MAIN-SPEAKER
- S18A, S18B REMOTE-SPEAKER
- S19A POWER SW.
- S20A PHONO-2 IMPEDANCE SELECTOR
(1. 100K, 2. 50K, 3. 30K)
- S21A, S21B PRE-OUT MAIN-IN CONNECT. SW.
- S22A, S22B AUX-1 LEVEL SET SELECTOR
(1. PREVU 2. MAIN-14dB. 3. MAIN-0dB)
- VR1A, VR1B VOLUME CONTROL
- VR2A, VR2B BALANCE CONTROL
- VR3A, VR3B BASS CONTROL
- VR4A, VR4B TREBLE CONTROL
- VR5A, VR5B AUX-1 LEVEL SET
- VR6A, VR6B MAIN-AMP LEVEL SET
- Q1 - Q4 2SC1000
- Q5 - Q10 2SC1000
- Q11 - Q16 2SC1000
- Q17 - Q24 2SC1000
- Q25 - Q28 2SC1000
- Q29 - Q32 2SC1000
- Q33 - Q34 2SC1000
- Q35 - Q36 2SC1000
- Q37 - Q38 2SC1000
- Q39 - Q40 2SC1000
- Q41 - Q42 2SC1000
- Q43 - Q44 2SC1000
- Q45 - Q46 2SC1000
- Q47 - Q48 2SC1000
- Q49 - Q50 2SC1000
- D1, D2 1S1850
- D3 - D5 1N4001
- D6, D7 1N4001
- D8, D9 1N4001
- D10 - D14 1N4001
- D15 - D16 1N4001
- D17 - D18 1N4001
- D19 - D20 1N4001
- D21 - D22 1N4001
- D23 - D24 1N4001
- D25 - D26 1N4001
- D27 - D28 1N4001
- D29 - D30 1N4001
- D31 - D32 1N4001
- D33 - D34 1N4001
- D35 - D36 1N4001
- D37 - D38 1N4001
- D39 - D40 1N4001
- D41 - D42 1N4001
- D43 - D44 1N4001
- D45 - D46 1N4001
- D47 - D48 1N4001
- D49 - D50 1N4001
- D51 - D52 1N4001
- D53 - D54 1N4001
- D55 - D56 1N4001
- D57 - D58 1N4001
- D59 - D60 1N4001
- D61 - D62 1N4001
- D63 - D64 1N4001
- D65 - D66 1N4001
- D67 - D68 1N4001
- D69 - D70 1N4001
- D71 - D72 1N4001
- D73 - D74 1N4001
- D75 - D76 1N4001
- D77 - D78 1N4001
- D79 - D80 1N4001
- D81 - D82 1N4001
- D83 - D84 1N4001
- D85 - D86 1N4001
- D87 - D88 1N4001
- D89 - D90 1N4001
- D91 - D92 1N4001
- D93 - D94 1N4001
- D95 - D96 1N4001
- D97 - D98 1N4001
- D99 - D100 1N4001

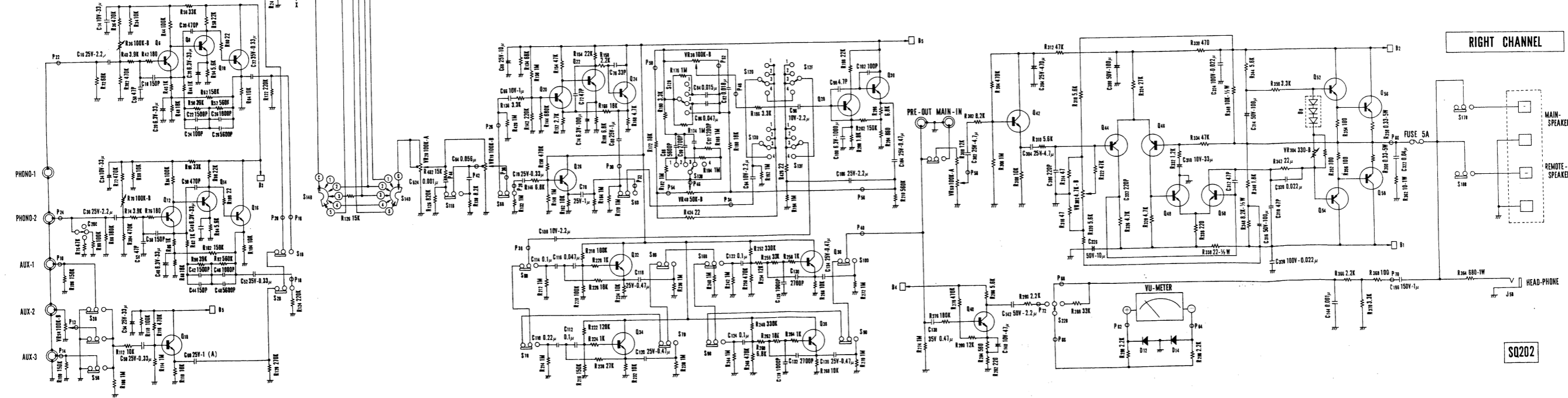
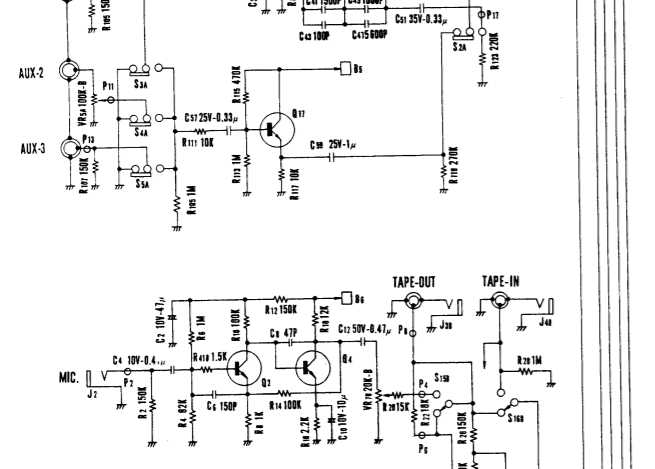

Frequency Response

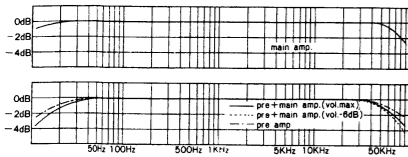

Phono Withstand Input Voltage

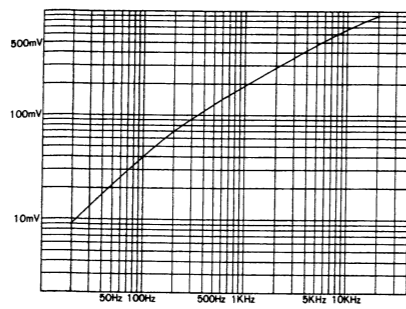

Intermodulation Distortion in Power Amplifier Section (8Ω load)

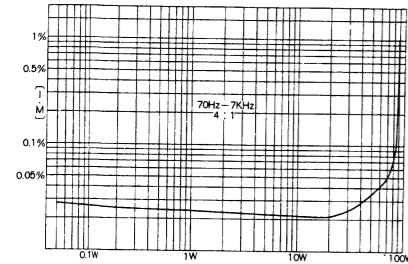

Loudness Control

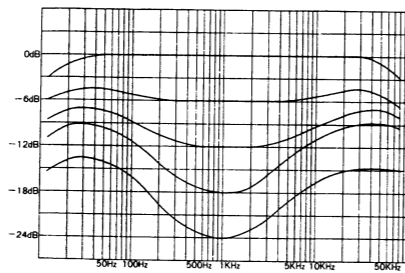

Bass Tone Control

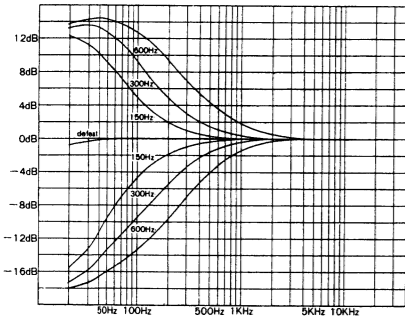

Filter

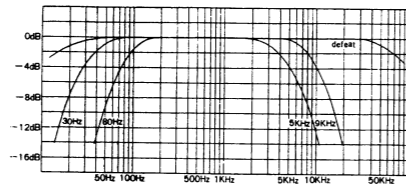

Treble Tone Control

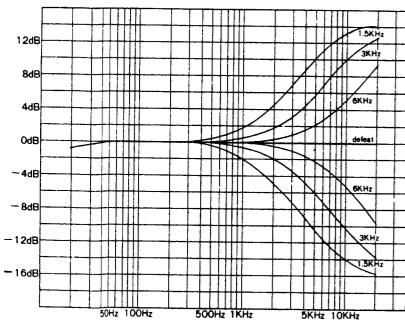

Damping Factor (8Ω load 2W output)

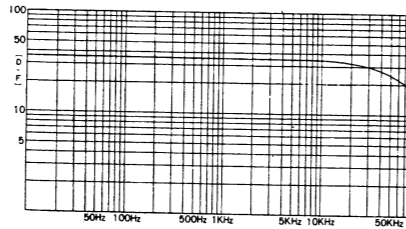

Total Harmonic Distortion in Power Amplifier Section (8Ω load)

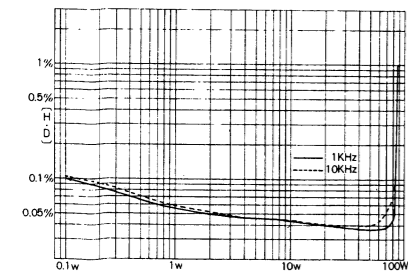

Equalizer (RIAA)

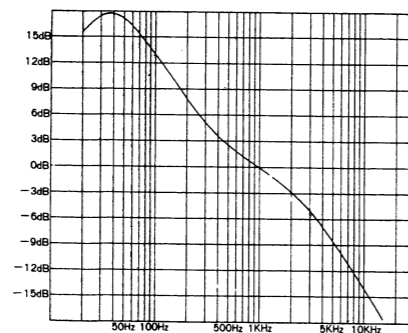

LUX CORPORATION, JAPAN

head office & factory 2-22, nagahashi-dori, nishinari-ku, osaka phones: 632 0031 cable: luxelect osaka
international division baba bldg. no.13, 2-23, yushima, bunkyo-ku, tokyo phones: 833 7691 cable: tokluxman tokyo