

SERVICE MANUAL



Stereo Integrated Amplifier

M-117

REVISED

- Serial Numbers after No.81210651 -A for M-117 (North American) model
- Concerning the contents not to be given in this manual, refer to the service manual (68P92578F02)

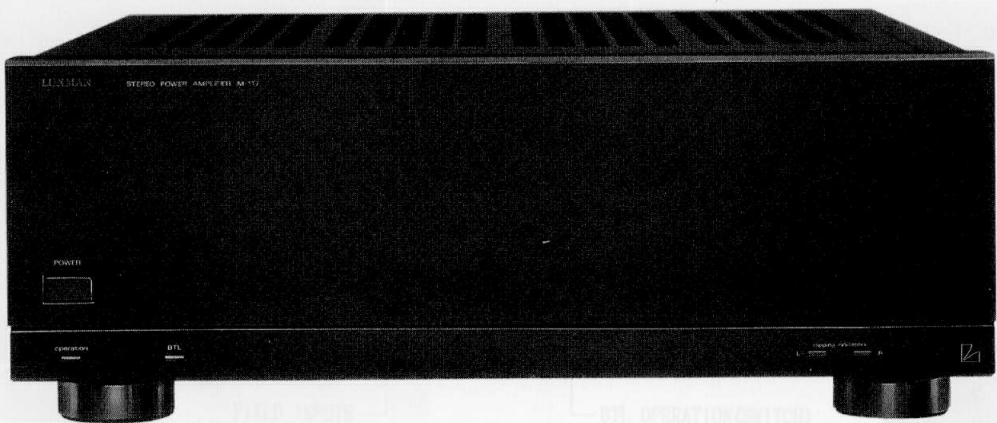

Semi-Conductor Lead Identifications

TA7317P: IC301

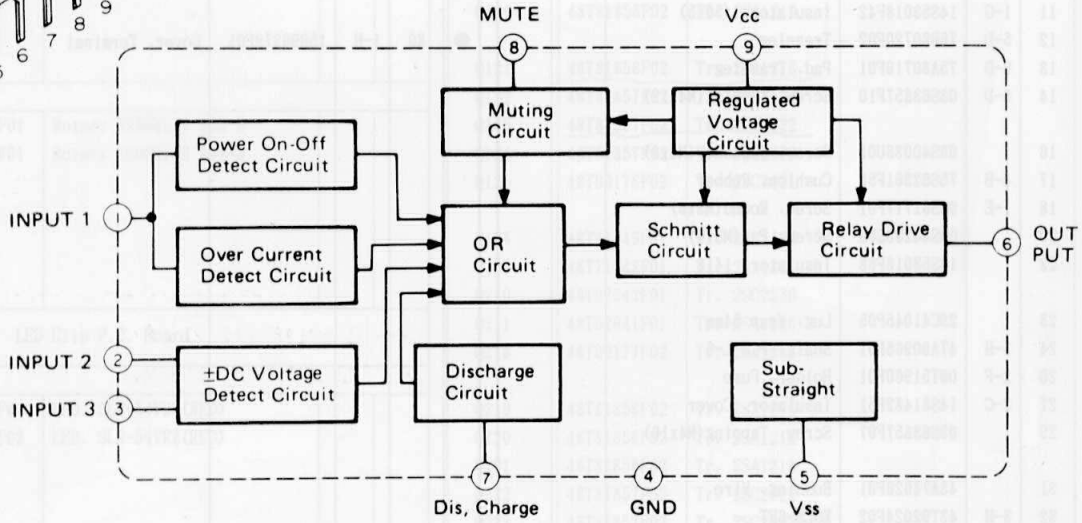
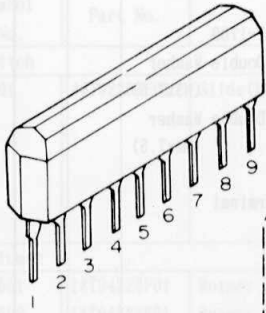

NJM78M12A: IC302

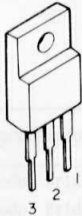

- 1. Output
- 2. Common
- 3. Input

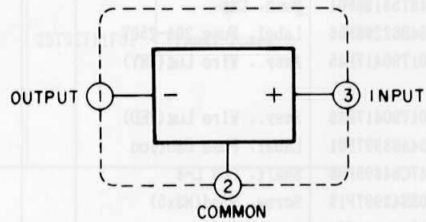

2SA995 :Q101,201
2SC2291:Q102,202

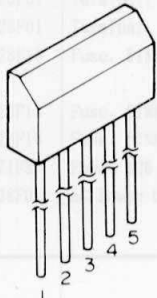

- 1. Emitter 1
- 2. Collector 1
- 3. Base (Common)
- 4. Collector 2
- 5. Emitter 2

2SA1208:Q103,104,203,204



- 1. Emitter
- 2. Collector
- 3. Base

Schematic Diagram

4. Removal of Main-Amp(R) P.C. Board

- (1) After removal of Heatsink(R) remove twenty two screws marked " * " as shown in Figure 6.

NOTE: Take care of handling each transistors when removing the Main-Amp(R) P.C. Board.

5. Removal of Heatsink(L) and Main-Amp(L) P.C. Board

- (1) Remove in the same way above mentioned.

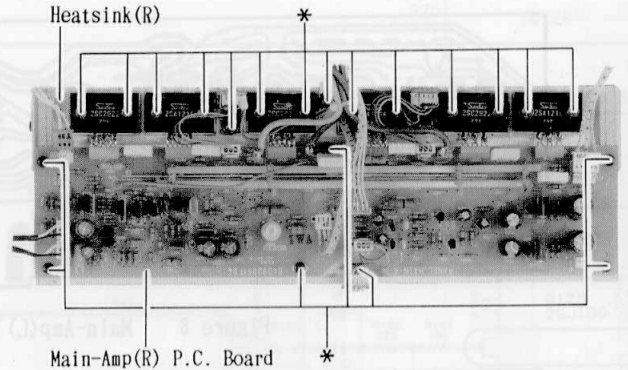

Figure 6

Adjustment Procedures

1. Connection

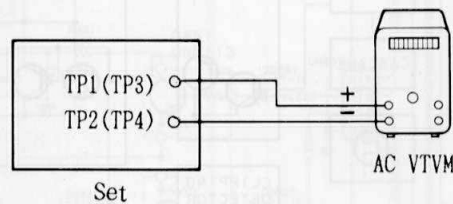

Figure 7

2. Control Setting

Attenuator(Left).....	Minimum	Power Switch	ON
Attenuator(Right)	Minimum	Others	OFF

3. Adjustment Procedure

- (1) Idling Adjustment(Figure 7.8 and 9)

Adjust VR101(VR201) so that voltage between TP1(TP3) and TP2(TP4) reaches $4 \pm 0.5\text{mV}$

Adjustment Locations

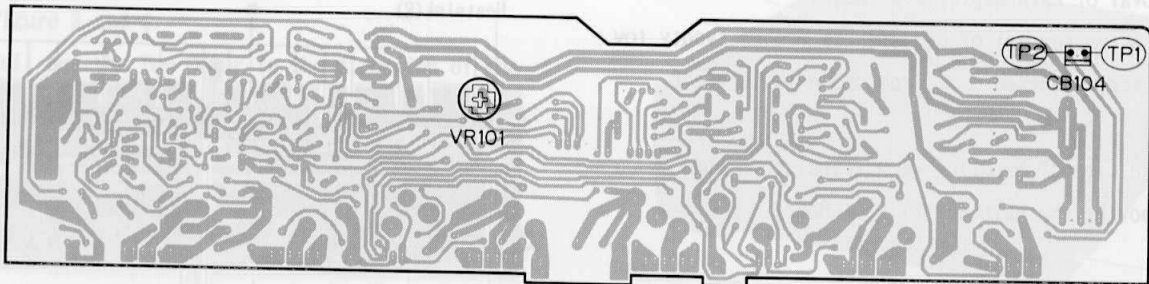

Figure 8 Main-Amp(L) P.C. Board(Component Side)

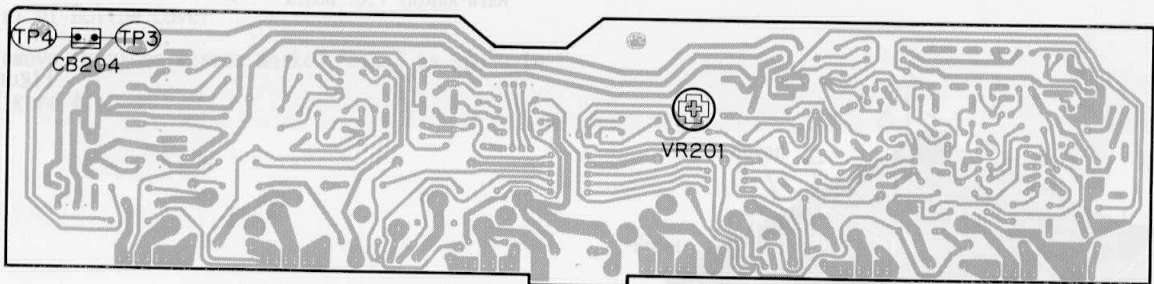
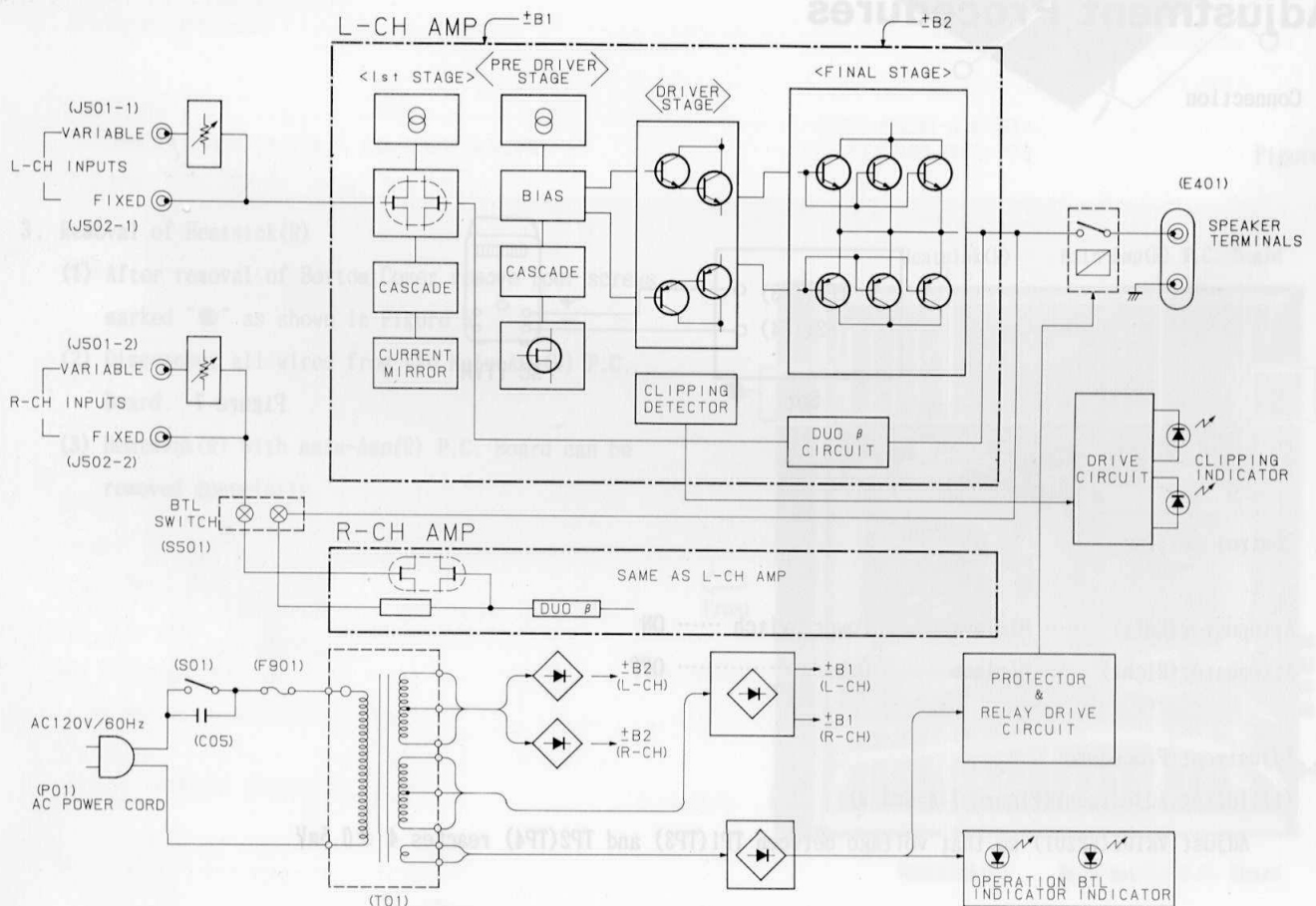

Figure 9 Main-Amp(R) P.C. Board(Component Side)

Block Diagram



Schematic Diagram

IC																	
Transistors (Q)	Q853	Q854	Q855	Q851	Q852	Q103	Q101	Q102	Q203	Q201	Q202	Q126	Q226	Q104	Q204	Q107	Q109

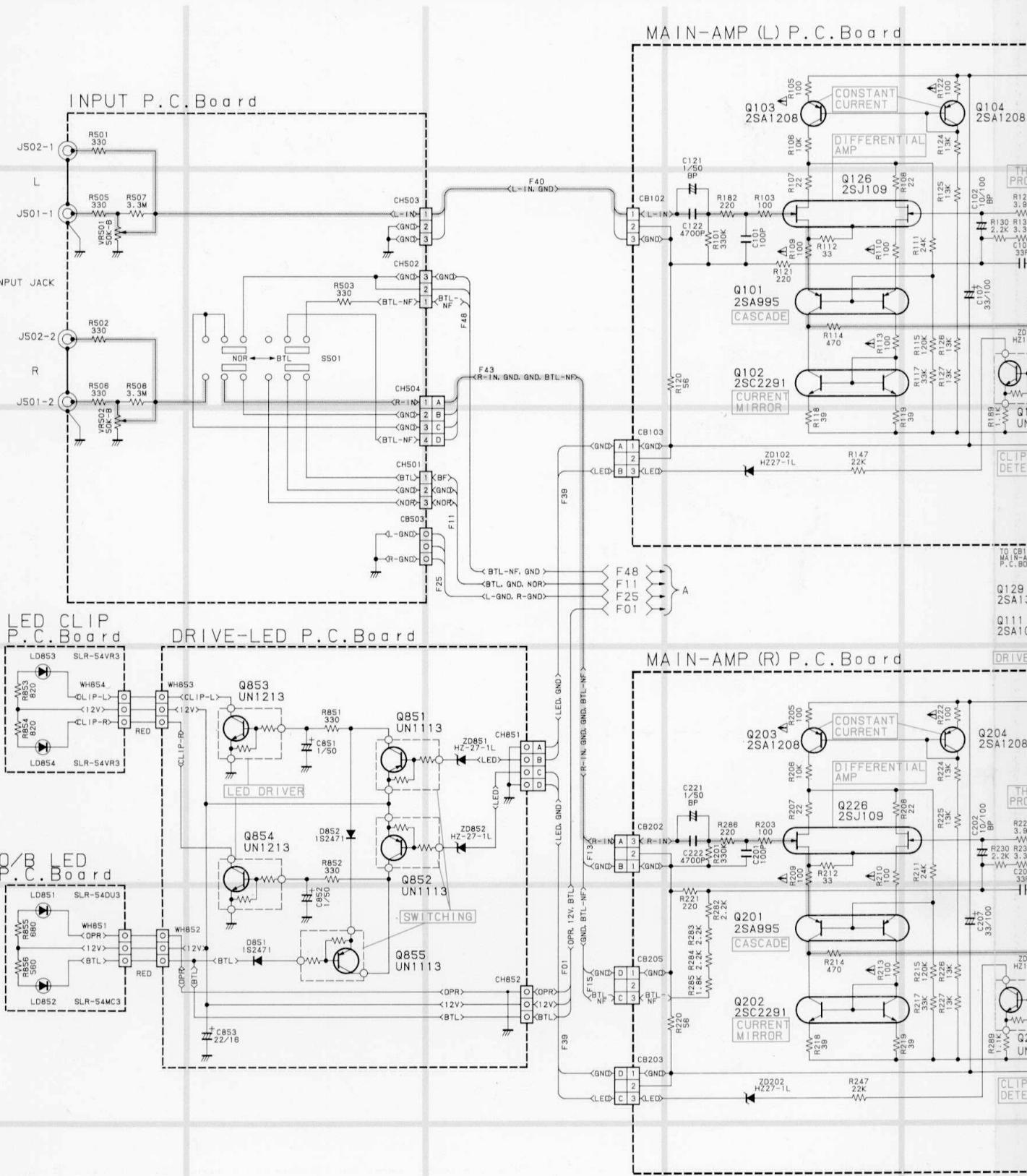

IC301

IC302

NOTES:

- 1. All resistance values are in ohms, K=1,000
- 2. All capacitance values are in microfarads, P= $\frac{1}{1,000,000}$

Voltage Measuring Conditions

- Power Supply Voltage: AC 120V
- Measuring Meter: Digital Volt Meter
- Measuring point reference: Between Ground
- Measuring conditions: No Signal Input

Terminal Voltage

	1	2	3	4	5	6	7	8	9
IC301	-0.5V	0V	0V	0V	-0.7V	1.9V	0V	1.2V	2.7V
IC302	12.1V	0V	17V						

SPEAKER TERMINAL P.C.Board

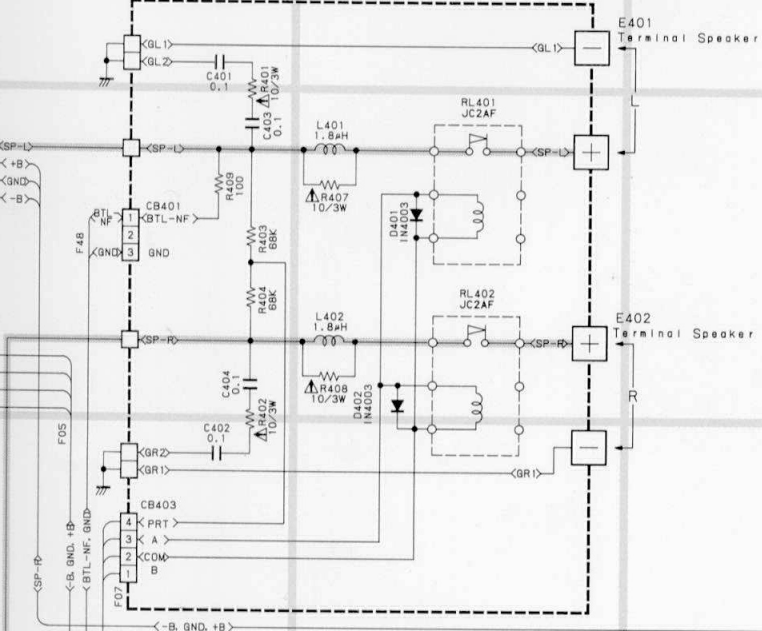

Q	L			R		
	E	C	B	E	C	B
Q101	-10.85V	-79.2V	-11.35V	-10.85V	-79.2V	-11.35V
Q102	-81.5V	-79.2V	-80.9V	-81.5V	-79.2V	-80.9V
Q103	81.2V	34.1V	80.7V	81.2V	34.1V	80.7V
Q104	81.4V	80.7V	80.7V	81.4V	80.7V	80.7V
Q105	80.1V	1.83V	79.5V	80.1V	1.83V	79.5V
Q106	-78.6V	-1.84V	-78V	-78.6V	-1.84V	-78V
Q107	-81.5V	-43.5V	-81.2V	-81.5V	-43.5V	-81.2V
Q108	0V	1.9V	0V	0V	1.9V	0V
Q109	0V	-1.9V	0V	0V	-1.9V	0V
Q110	0.6V	79V	1.2V	0.6V	79V	1.2V
Q111	-0.6V	-79V	-1.2V	-0.6V	-79V	-1.2V
Q112	-0.2V	80.5V	0V	-0.2V	80.5V	0V
Q113	81.6V	82.8V	82.2V	81.6V	82.8V	82.2V
Q114	82.2V	82.8V	82.7V	82.2V	82.8V	82.7V
Q115	-82.2V	-82.8V	-82.7V	-82.2V	-82.8V	-82.7V
Q116	-81.6V	-82.8V	-82.2V	-81.6V	-82.8V	-82.2V
Q117	74.2V	-0.54V	81.2V	74.2V	-0.54V	81.2V
Q118	12.1V	0V	11.9V	12.1V	0V	11.9V
Q119		-79V			-79V	
Q120		-79V			-79V	
Q121		-79V			-79V	
Q122		79V			79V	
Q123		79V			79V	
Q124		79V			79V	
Q125	-1.84V	1.83V	1.26V	-1.84V	1.83V	1.26V
Q128	1.2V	79V	1.8V	1.2V	79V	1.8V
Q129	-1.2V	-79V	-1.8V	-1.2V	-79V	-1.8V

Q	S	D	G
Q126	-0.44V	-10.7V	0V
Q127	-78.6V	-81.2V	-79V
Q226	-0.44V	-10.7V	0V
Q227	-78.6V	-81.2V	-79V

Q	E	C	B
Q851	12V	0V	12V
Q852	12V	0V	12V
Q853	0V	12V	0V
Q854	0V	12V	0V
Q855	0V	0V	12V

POWER SUPPLY P.C.Board

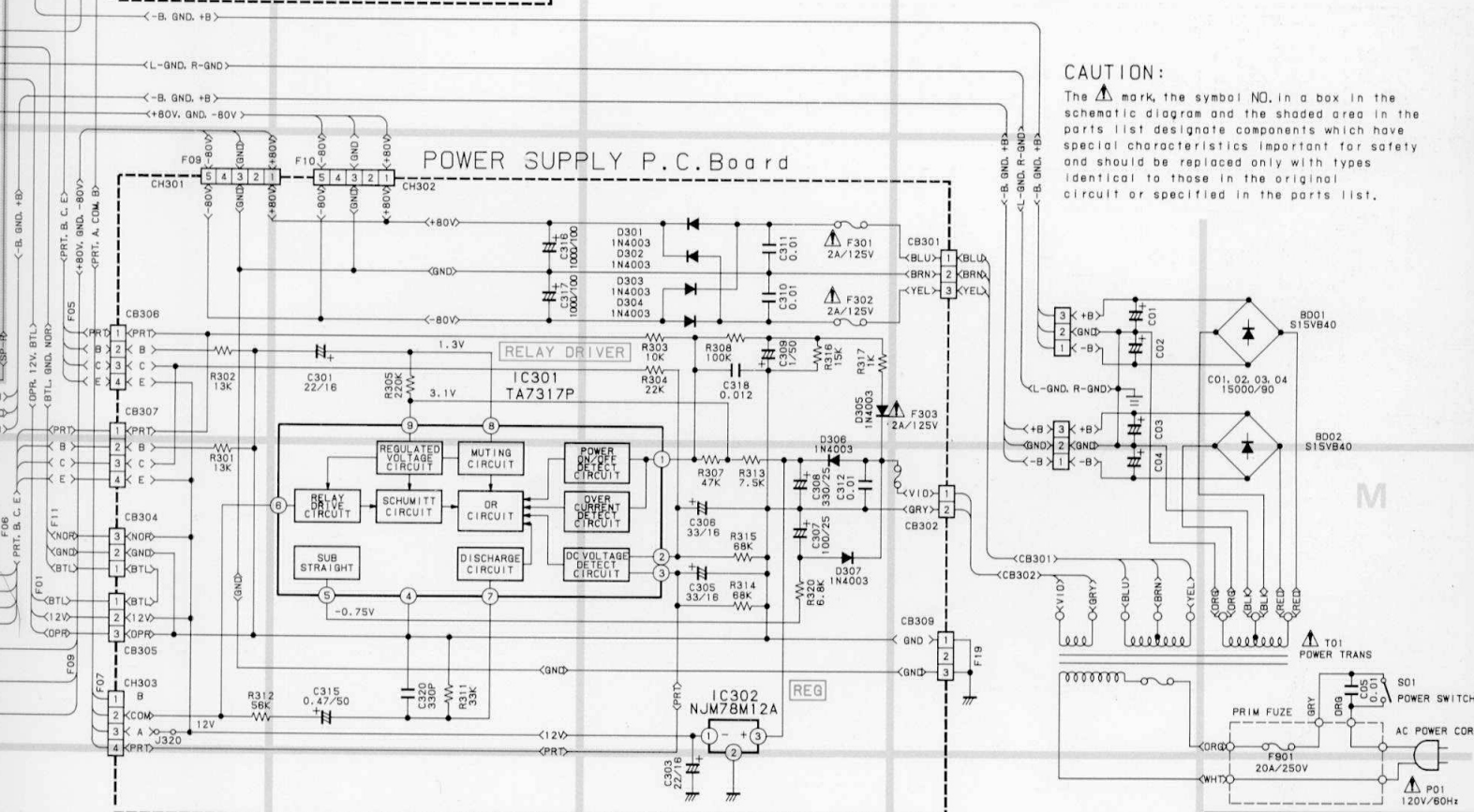

CAUTION:

The Δ mark, the symbol NO, in a box in the schematic diagram and the shaded area in the parts list designate components which have special characteristics important for safety and should be replaced only with types identical to those in the original circuit or specified in the parts list.

M-117