

# SERVICE MANUAL

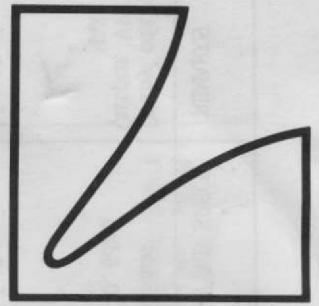

LUXMAN STEREO CASSETTE DECK

# K-12



Section Alignment Procedure]

TAPE REQUIRED	SELECTOR POSITION		INPUT SIGNAL	ALIGNMENT PROCEDURE	LIMITED SPEC	R
	EQ SW	BIAS SW				
MITT-150	NORMAL	NORMAL		Playback TEAC MITT-150 (Dolby level: 400Hz 200nWb/m) and adjust trimmer potentiometer to obtain output level of 580mV(-2.5dBm).  Lch P/B Gain VR: VR-107a Rch P/B Gain VR: VR-107b	-2.5dBm ±0.5dBm	Do Ou
MITT-150	CrO <sub>2</sub>  EX	NORMAL  NORMAL		After the step (1), check the P/B output level at the "CrO <sub>2</sub> " mode.  Also check that at "EX" mode.	-2.5dBm ±0.5dBm	If le be am ma pe
MITT-150	NORMAL	NORMAL		Set the Dolby Sw to ON and adjust trimmer pot for Dolby level adjust to obtain output level of 580mV (-2.5dBm) at LINE OUT jack.  Lch Dolby Gain VR: VR103a Rch Dolby Gain VR: VR103b		Do
MITT-150	NORMAL	NORMAL		Set the Dolby Sw to "MPX filter" position and check the Dolby output level at LINE OUT jack.		Do "M po ou am ma pe
MITT-150	NORMAL	NORMAL		Adjust trimmer pot for bar-graph level adjust to obtain 0VU indication at 580mV output level of LINE OUT.  Lch Bar-Graph Level Adjust VR: VR104a Rch Bar-Graph Level Adjust VR: VR104b	0dB ± 0.5dB (0dB level should light up.)	
MITT-216	NORMAL	NORMAL		Playback MITT-216 (3180uS +120uS) to reproduce the azimuth alignment signals (6.3kHz, 10kHz), and adjust the azimuth adjust screw to obtain the maximum playback output level.  Also check, monitoring an oscilloscope, if there is no phase-shifting between L and R channels.		t
MITT-216	NORMAL	NORMAL		Playback MITT-216 to check that the first standard signal (315Hz) should be at -5.5dBm ± 0.5dBm. Then reproduce 10kHz signal, and adjust P/B EQ trimmer to obtain output level of -25.5 -0.5dBm.  Lch P/B EQ trimmer pot : VR-108a Rch P/B EQ trimmer pot : VR-108b	10kHz output level: -25.5 ± 0.5dBm	

	TAPE REQUIRED	SELECTOR EQ SW	POSITION BIAS SW	INPUT SIGNAL	ALIGNMENT PROCEDURE	LIMITED
t.	MIT-216	NORMAL	NORMAL		Playback MIT-216 standard frequency response signal (315Hz), and make note of the output level. Then playback the frequency adjustment signal from 31.5Hz to 14kHz. At this time, the playback output level at each frequency should be within -2dBm when the standard output level is regarded as zero (0).	Should be within -2dBm, referencing 315Hz signal as 0.
t.	MIT-316	CrO <sub>2</sub> EX	NORMAL		Set EQ Selector to "CrO <sub>2</sub> " (or "EX") position. Playback standard frequency signal 315Hz of MIT-316 (3180uS+70uS), and make note of the output level. Then playback frequency alignment signal from 31.5Hz to 14kHz. At this time, the playback output level at each frequency should be within -2dBm when the standard output level is regarded as zero (0).	Should be within -2dBm, referencing 315Hz signal as 0 (zero).
		NORMAL	NORMAL		Put the deck to "PLAY" mode without loading cassette hub, and check noise level at LINE OUT Jacks. Noise Level ----- no more than -50dBm(RMS) Likewise, check that at the respective mode: "CrO <sub>2</sub> ", "EX", "Dolby ON", "MPX.FILTER" and "PAUSE".	Should be no more than -50dBm at each mode
st.		CrO <sub>2</sub>	CrO <sub>2</sub>		Connect counter to the current output terminals of erasing head [terminal No. 19 (+), No. 18 (-)]. Set the BIAS Sw. to "CrO <sub>2</sub> " mode. Turn the BIAS OSC coil to obtain 105kHz oscillation frequency. BIAS OSC Coil --- L-201 Also check if oscillation frequency at each "NORMAL" and "EX" position is 105kHz ±5kHz.	Bias OSC frequency: 105kHz at CrO <sub>2</sub> 105kHz ± 5kHz at NORMAL & EX
st.		EX	EX		Connect VTVM before trap coil at REC EQ AMP for both L and R channels, and adjust trap coil to obtain minimum reading of VTVM. Trap Coil --- L-ch L-103a --- R-ch L-103b At this time, the VTVM indication should be no more than +20dBm.	VTVM reading should be no more than +20dBm.
dj.		NORMAL	NORMAL CrO <sub>2</sub> EX	no signal	Connect VTVM across the 10-ohm resistor of the record head. L-ch Terminal No. 42 ----- (+) Terminal No. GND ----- (-) R-ch Terminal No. 48 ----- (+) Terminal No. GND ----- (-)  (1) Set the BIAS sw to "NORMAL", and pre-set the current-flow through the 10-ohm resistor to 300µA. Trimmer Pot for NORMAL BIAS ADJ. -- Lch VR202a Rch VR202b	NORMAL 300µA (=3mV, at 10 ohms)

TAPE REQUIRED	SELECTOR EQ SW	POSITION BIAS SW	INPUT SIGNAL	ALIGNMENT PROCEDURE	LIMITED SPEC	RE
				<p>(2) Set the BIAS sw to "CrO<sub>2</sub>", and preset the BIAS current to 400<math>\mu</math>A. Trimmer Pot for CrO<sub>2</sub> BIAS Adj. -- Lch VR201a Rch VR203b</p> <p>(3) Set the BIAS sw to "EX", and preset the BIAS current to 650<math>\mu</math>A. Trimmer Pot for EX BIAS Adj. -- Lch VR203a Rch VR201b</p>	<p>CrO<sub>2</sub> 400<math>\mu</math>A (=4mV, at 10 ohms)</p> <p>EX 650<math>\mu</math>A (= 6.5mV, at 10 ohms)</p>	"F"
	NORMAL	NORMAL	18kHz 100mV (-18dBm)	<p>To keep out the action of BIAS OSC, insert a tip of paper in the leaf switch connected in series with the power supply to the oscillator. (The leaf Sw is placed near the main solenoid.) Then put the deck into the "REC" mode.</p> <p>(1) Set the Equalizer Sw to the "NORMAL" position, and apply 18kHz 100mV signal to LINE INPUT. Adjust the peaking coil for NORMAL to obtain the maximum output at the 10-ohm resistor of the R/P head. Peaking Coil for NORMAL --- Lch L105a Rch L105b</p>	Adjust peaking for NORMAL mode by use of 18kHz signal	Out be acr 10- res "RE"
	CrO <sub>2</sub>		20kHz	<p>(2) Set the Equalizer Sw to the "CrO<sub>2</sub>" position and apply 20kHz 100mV signal to LINE INPUT. Adjust the peaking coil for CrO<sub>2</sub> to obtain the maximum reading on the VTVM. Peaking Coil for CrO<sub>2</sub> --- Lch L104a Rch L104b</p>	Adjust peaking for CrO <sub>2</sub> mode by use of 20kHz signal	
	EX		21kHz	<p>(3) Set the Equalizer Sw to the "EX" position and apply 21kHz 100mV signal to LINE INPUT. Adjust the peaking coil for EX to obtain the maximum reading on the VTVM. Peaking Coil for EX --- Lch L106a Rch L106b</p> <p>Each peaking level at the respective mode, NORMAL CrO<sub>2</sub> and EX should be approximately 20dBm at 18kHz, 20kHz, 21kHz, compared with that of 1kHz</p> <p>(4) Do not forget to remove a piece of paper put on the leaf switch.</p>	Adjust peaking for EX mode by use of 21kHz signal	
AC-221	NORMAL	NORMAL	400Hz, 100 $\mu$ V <sup>+</sup> 3dB(-18dBm-3dB) Output level at LINE OUT, monitoring source, should be 580mV	<p>Adjust the REC Gain trimmer pot to obtain LINE OUT output level of 580mV(-2.5dBm) when the AC-221 tape 400Hz signal is recorded and played-back. NORMAL REC Gain Adjustment Lch VR110a Rch VR110b</p>	-2.5 <sup>+</sup> 0.5 dBm	Inp at sho -18

	TAPE REQUIRED	SELECTOR POSITION		INPUT SIGNAL	ALIGNMENT PROCEDURE	LIMITED SPEC
		EQ SW	BIAS SW			
	AC-511	CrO <sub>2</sub>	CrO <sub>2</sub>	400Hz, 100mV $\pm$ 3dB (-18dBm $\pm$ 3dB) Output level at LINE OUT, moni- toring source, should be 580mV	Adjust the REC Gain trimmer pot to obtain LINE OUT output level of 580mV(-2.5dBm) when the AC-511 tape 400Hz signal is recorded and played-back. CrO <sub>2</sub> REC Gain Adjustment Lch VR109a Rch VR109b	-2.5 $\pm$ 0.5dBm
adjust.	metal particle tape (AC-701)	EX	EX	Same as above.	Take the same alignment procedure described in step (16). EX REC Gain Adjustment Lch VR111a Rch VR111b	
Dis- at		EX	EX		Check that the Bar Graph Indication at the "EX" mode is lower by 4dB compared to that of other modes. Note that this lower indication is realized only when both of the EQ sw and BIAS sw are in the "EX" position.	-4dB indication of the Bar Graph at the "EX" position of EQ sw & BIAS sw.
cy just.	AC-221	NORMAL	NORMAL	30-16kHz -20dB against stan- dard input level	Record 30Hz - 16kHz signal (-20dB against the stan- dard input level) from LINE INPUT, and playback. Check that the output level at each frequency is 0 -3dB when 400Hz output is regarded as 0dB.	0 $\pm$ 3dB at each frequency
cy just.	AC-511	CrO <sub>2</sub>	CrO <sub>2</sub>	30-18kHz -20dB against stan- dard input level	Record 30Hz - 18kHz signal(-20dB against the stan- dard input level) from LINE INPUT, and playback. Check that the output level at each frequency is 0 -3dB when 400Hz output is regarded as 0dB.	0 $\pm$ 3dB at each frequency
cy j.	metal particle tape (AC-701)	EX	EX	30-20kHz -20dB against stan- dard input level	Take the same alignment procedure described in (20) except the frequency range is from 30Hz to 20kHz.	0 $\pm$ 3dB at each frequency
cy ust. case	AC-221 AC-511 metal particle tape (AC-701)	NORMAL CrO <sub>2</sub> EX	NORMAL CrO <sub>2</sub> EX	30 - 16kHz 30 - 18kHz 30 - 20kHz  -20dB against standard input level	In case the frequency response does not meet the limited specification during the procedure steps (19)- (20), take the following procedure. a) When the Freq. resposne shows drop both at 4-8kHz (midrange) and over 15kHz(treble). See fig. 1 ----- Lower the bias current. (Turn the VR coun- ter-clockwise direction.) When they are both increased. See fig. 2 ----- Increase the bias current. (Turn the VR clockwise.) b) When the frequency response drops only at treble range (over 10kHz). See fig. 3 ----- Shift peaking point downward by turning the peaking coil clockwise. When the response increases only in treble range. See fig. 4 ----- Shift peaking point upward by turning the peaking coil counter-clockwise.	RESPONSE RESPONSE RESPONSE fig. 1 fig. 2



	TAPE REQUIRED	SELECTOR EQ SW	POSITION BIAS SW	INPUT SIGNAL	ALIGNMENT PROCEDURE	LIMITED SPEC	
	AC-221	NORMAL	NORMAL	400Hz standard input signal level(0dB level on the Bar Graph)	Apply 400Hz standard input signal to LINE IN and record/play-back it. The output level at LINE OUT terminal should be 580mV $\pm$ 1dB both for Dolby ON and OFF	580mV $\pm$ 1dB	Dol Do
N -	AC-221 AC-511 metal particle tape (AC-701)	NORMAL CrO <sub>2</sub> EX	NORMAL CrO <sub>2</sub> EX	no signal	Unload the LINE IN terminals, and make record/playback of the tape. The noise level at this time should be less than -47dBm(RMS).  Check the noise level at CrO <sub>2</sub> and EX position in the same manner.  Both at the "Dolby ON" and "Dolby MPX Filter ON", the noise level should be less than -49dBm.	Record/Play- back noise level should be less than -47dBm(RMS).  Record/Play- back noise level should be less than -49dBm(RMS).	
re	AC-221 AC-511 metal particle tape (AC-701)	NORMAL CrO <sub>2</sub> EX	NORMAL CrO <sub>2</sub> EX	1kHz +10dB against stan- dard input level	Apply 1kHz -8dBm signal to LINE IN terminal, and record it. Next, make note of the output level. Then, disconnect the input signal and erase the recorded signal. Check the output level at the erased portion through 1kHz band-pass filter, and make note of the difference compared with that before erasing. Output Level before erasing ----- a1 (dBm) Output Level after erasing ----- a2 (dBm) Erasing Capability ----- A = a1-a2(dBm) Take the same procedure in the "CrO <sub>2</sub> " and "EX" modes.	Erasing Capability A should be better than 70dBm	Us ba fi
k	AC-221 AC-511 metal particle tape (AC-701)	NORMAL CrO <sub>2</sub> EX	NORMAL CrO <sub>2</sub> EX	1kHz standard input level (0dB level at the Bar Graph)	Record 1kHz about -18dBm signal through Lch LINE IN, and play-back it. Then measure the record/playback output level of Rch via 1kHz band-pass filter. At the same time measure the record/playback output of Lch.  Record/Playback Output Level (Lch) --- a1 (dBm) Record/Playback Output Level (Rch) --- a2 (dBm) Crosstalk from Lch to Rch: A = a1 - a2 (dB)  Likewise apply signal to Rch to measure the crosstalk from Rch to Lch. Take the same procedure at each mode with Dolby ON.	better than 35dB	Us ba fi Do
	MIT-121				Play-back test tape MIT-121, and measure the leakage as per the following mode.  Lch to Rch (1st track to 2nd track) Rch to Lch (2nd track to 1st track)	better than 50dB	Us ba fi

-----K-12 MECHANICAL PART ALIGNMENT PROCEDURE-----

TAPE REQUIRED	SELECTOR EQ SW	POSITION BIAS SW	INPUT SIGNAL	ALIGNMENT PROCEDURE	LIMITED SPEC
				<p>1) Confirm that the deck does not stop and that the cassette lid does not open even when the Eject Button is pressed during operation.</p> <p>2) Confirm that in the modes of "FF" and "REW" with a touch to the Eject Button the deck stops operation prior to opening of the cassette lid.</p> <p>Confirm that the bias osc. switch is turned on when the head chassis functions and that it is not turned off at the STOP mode.</p>	
MTT-111D				Connect a digital counter to the LINE OUTPUT, and with MTT-111D tape the digital counter shows 2,985 - 3,015Hz.	Tape speed: 2,985-3,015Hz
MTT-111D				The wow tape MTT-111D is loaded, and a wow meter is connected to the LINE OUT terminal. Wow is measured both at RMS and WRMS.	RMS: below 0.1% WRMS: below 0.04%



Key Switch PCB

SYMBOL NO.	PART NUMBER	DESCRIPTION	NOTE	QUANTITY PER UNIT
	PCM-004	Key Switch PCB	PCM004	1
	S-0018	Key Tact Switch		7
	A-0021	Lamp	5V0.075A	3
	YM-0199	Bush 3008		3

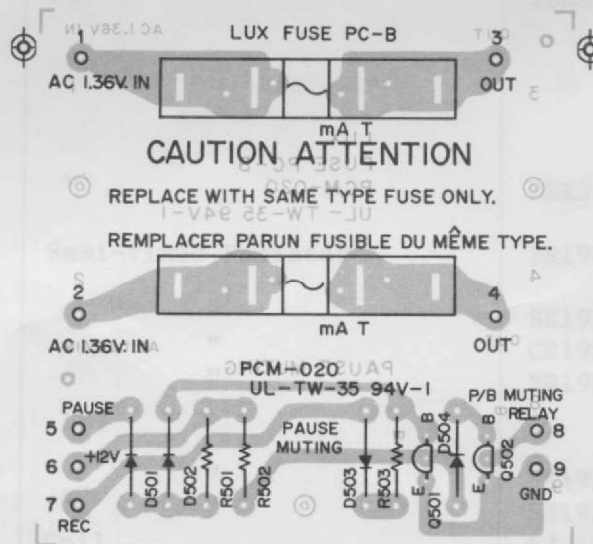
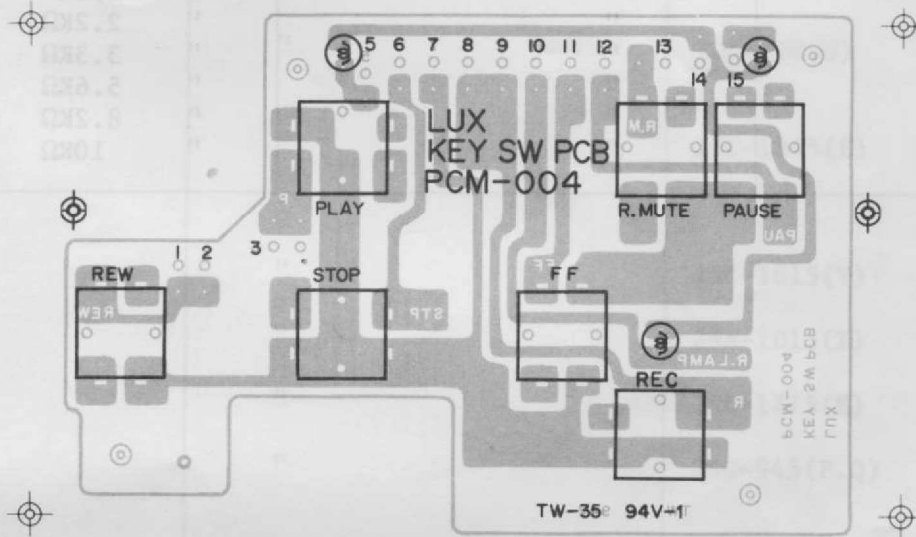

Fuse PCB

SYMBOL NO.	PART NUMBER	DESCRIPTION	NOTE	QUANTITY PER UNIT
		Fuse PCB	PCM-020	1
Q501, 502	T-0025	Transistor	2SC2320F	2
D501 ~ 504	T-0010	Diode	1S-2473	4
R503	R-0001	Carbon Resistor	1/4W 3.9K $\Omega$	1
R502	"	"	" 10K $\Omega$	1
R501	"	"	" 47K $\Omega$	1

Sensor PCB

SYMBOL NO.	PART NUMBER	DESCRIPTION	NOTE	QUANTITY PER UNIT
Q1 ~ 4	T4-28334	Sensor, PCB		1
C2		Transistor	2SC828(RS)	4
C3		Myler Capacitor	0.027 $\mu$ F/50V	1
C1		Electrolytic Capacitor	10 $\mu$ F/16V	1
R1, 2		" (NP)	10 $\mu$ F/16V	1
R8		Carbon Resistor	ERD25UJ 220 $\Omega$	2
R12		"	" 330 $\Omega$	1
R5, 7, 9		"	" 390 $\Omega$	1
R11		"	" 2.2K $\Omega$	3
R6, 10		"	" 3.3K $\Omega$	1
R3		"	" 5.6K $\Omega$	2
R4		"	" 8.2K $\Omega$	1
		"	" 10K $\Omega$	1

## Amp. PCB

SYMBOL NO.	PART NUMBER	DESCRIPTION	NOTE	QUANTITY PER UNIT
	PCM-006	Amp. PCB	PLC-2242	1
	S-0011	Rotary Slide Sw (REC EQ)	SRZ-V063S	1
	S-0010	Rotary Slide Sw (Dolby)	SRZ-L083	1
RY101a, b	L-0002	Record/Playback Relay	FRL-414D 012/04CT	2
RY002, 001	L-0001	Muting Relay	BR221D012	2
IC101a, b	IC-0006	Dolby IC	NE645B	2
Q101a, b		Transistor	2SC-1345(E)	6
102a, b		"	"	"
103a, b		"	"	"
Q106a, b		"	2SA-798(G)	6
114a, b		"	"	"
121a, b		"	"	"
Q107a, b		"	2SC-1345(E)	8
108a, b		"	"	"
122a, b		"	"	"
123a, b		"	"	"
Q109a, b		"	2SC-1815(Y)	4
111a, b		"	"	"
Q110a, b		"	2SA-1015(Y)	3
011		"	"	"
Q115a, b		"	2SC-1775(E)	4
117a, b		"	"	"
Q001~005, 007~010, 012		"	2SC-945(P.Q)	10
Q116a, b		"	2SA-872(E)	2
Q006		"	2SD-592(R)	1
Q104a, b		FET	2SK68A L1	12
105a, b		"	"	"
112a, b		"	"	"
113a, b		"	"	"
119a, b		"	"	"
120a, b		"	"	"
Q118a, b	T-0026	"	2SK30A	4
124a, b		"	"	"
VR103a, b	R-0009	Semi-fixed Resistor	SR19R-10K $\Omega$	4
107a, b		"	"	"
VR104a, b	R-0008	"	SR19R-47K $\Omega$	2
VR106a, b	R-0010	"	CR19R-220 $\Omega$	2
VR109a, b		"	SR19R-100K $\Omega$	6
110a, b		"	"	"
111a, b		"	"	"
VR108a, b		"	SR19R-47K $\Omega$	2
VR112a, b		"	SR19R-10K $\Omega$	2
L101a, b	L-0007	Coil	42-1092-01	4
107a, b		"	"	"
L103a, b		"	L-9-3	6
104a, b		"	"	"
106a, b		"	"	"
L105a, b		"	47mH	2
L102a, b	L-0003	Low Pass Filter	BL-21HF	2
C102a, b	C-0003	Electrolytic Capacitor	SM25VB-33	2
C104a, b	"	"	SM25VB-100	2
C110a, b	"	"	CX50VB-3R3BP	2
C111a, b	"	"	SM50VB-1	3
002		"	"	"
C112a, b	"	"	SM16VB-10	8
113a, b		"	"	"

SYMBOL NO.	PART NUMBER	DESCRIPTION	NOTE	QUANTITY PER UNIT
117a, b				
119a, b				
C122, 124a	"	"	SM16VB-220	4
124b, 003				
C128a, b	"	"	50VB-100BP	2
C154, 155	"	"	SM25VB-470	2
C004, 006	"	"	SM25VB-4R7	2
C149a, b	"	"	SM35VB-2R2	2
C133a, b	"	"	CX50VB-3R3BP	2
C156, 157	"	"	SM25VB-470	2
C005	"	"	SM25VB-22	1
C101a, b	C-0010	Solid Tantalum Capacitor	16V 1 $\mu$	4
105a, b				
C120a, b	"	"	16V 0.1 $\mu$	2
C121a, b	"	"	16V 0.33 $\mu$	2
C123a, b	C-0009	"	25V 1 $\mu$	2
C103a, b	C-0007	FM Capacitor	FM05ZC-220	6
106a, b				
137a, b				
C107a, b	"	"	FM05ZC-150K	12
108a, b				
130a, b				
131a, b				
138a, b				
139a, b				
C134a, b	"	"	FM11ZC-151K	2
C129a, b	"	"	FM13ZC-331K	2
C109a, b	C-0001	Metalized Polyester Film Cap.	412A1003-684K	2
C132a, b	"	"	412A1003-684K	2
C145a, b	"	"	412A1003-154K	2
C140a, b	"	"	412A1003-105K	2
C114a, b	C-0002	Polyester Film Capacitor	AMS50-562J	2
C116a, b	"	"	AMS50-472J	2
C115a, b	"	"	AMS50-273J	2
C118a, b	"	"	AMS50-473J	2
C135a, b	"	"	NP-500-562J	2
C142a, b	"	"	AMS50-223K	6
144a, b				
143a, b				
C163a, b	"	"	AMS50-273K	2
C146a, b	"	"	AMS50-104K	4
147a, b				
C158a, b		"	AMS50-104K	2
C164a, b		"	AMS50-393	2
C152a, b	C-0015	Ceramic Capacitor	DD104B101K50V02	2
C125a, b	"	"	DD106PH470J50V02	6
126a, b				
127a, b				
C143	"	"	DD110D103M50V02	1
C001, 153,	C-0012	"	DD314-957BC-104	3
161				
C162a, b		"	DD107PH680J50V02	2
C151a, b		"	FM05ZC220	2
C150a, b		"	100pF/50V	2
C141a, b	C-0004	Polystyrene Film Capacitor	NR-500-851J	2
D001~004,	T-0010	Silicon Diode	1S-2473	16
006~013,				
103a, b,				
104a, b				

SYMBOL NO.	PART NUMBER	DESCRIPTION	NOTE	QUANTITY PER UNIT
ZD001	T-0007	Zener Diode	WZ-040	1
D101a, b, 105a, b, 102a, b	T-0025		VD-1221	6
R106a, b, 111a, b, 165a, b, 006	R-0001	Carbon Resistor	R1/4-101J	7
R108a, b 138a, b	"	"	" 821J	4
R113a, b, 192a, b, 116a, b, 133, 134, 146a, b, 001, 015	R0001	"	" 102J	12
R105a, b, 115a, b, 019, 175a, 175b, 179a, 179b	"	"	" 222J	9
R110a, b, 129a, b, 156a, b, 160a, b, 162a, b, 202a, b	"	"	" 332J	12
R104a, b, 145a, b, 173a, b	R-0001	Carbon Resistor	R1/4-562J	6
R119a, b, 149, 176a, b	"	"	" 153J	5
R102a, b	"	"	" 333J	2
R103a, b, 137a, b, 193a, b	"	"	" 683J	6
R107a, b, 191a, b, 151a, b, 172a, b, 174a, b	"	"	" 104J	10
R112a, b, 168a, b	"	"	" 684J	4
R126a, b, 183a, b	"	"	" 680J	4
R127a, b	"	"	" 221J	2
R125a, b	"	"	" 122J	2
R122a, b, 181a, b	"	"	" 152J	4
R120a, b,	"	"	" 751J	2
R117a, b, 118a, b, 135a, b, 177a, b, 178a, b, 201a, b	"	"	" 472J	12
R109a, b, 185a, b	"	"	" 183J	4

SYMBOL NO.	PART NUMBER	DESCRIPTION	NOTE	QUANTITY PER UNIT
R124a, b, 152a, b, 153a, b, 157a, b, 158a, b, 167a, b, 182a, b, 190a, b	"	"	" 123J	16
R128a, b	"	"	" 823J	2
R180a, b, 121a, b	"	"	" 273J	4
R101a, b	"	"	" 393J	2
R123a, b, 130a, b, 171a, b, 021	"	"	" 473J	7
R131a, b	"	"	" 204J	2
R132a, b	"	"	" 274J	2
R198a, b	"	"	" 181J	2
R141a, b, 142a, b, 150a, b, 163a, b, 164a, b	"	"	" 100J	10
R143a, b	"	"	" 150J	2
R139a, b	"	"	" 330J	2
R140a, b	"	"	" 422J	2
R136a, b	"	"	" 124J	2
R155a, b	"	"	" 391J	2
R166a, b	R-0001	Carbon Resistor	R1/4-331J	2
R004, 005, 007, 008, 148a, b, 154a, b, 161a, b, 159a, b, 022, 189a, b, 115a, b	"	"	" 223J	17
R002, 003, 009, 010, 016, 017, 020, 147, 013, 194a, b, 196a, b	"	"	" 103J	13
R011	"	"	" 563J	1
R018, 014	"	"	" 392J	2
R186a, b, 187a, b	"	"	" 560J	4
R012, 169a, b	"	"	" 682J	3
R188a, b	"	"	" 820J	2
R199, 200	"	"	" 220J	2
R134a, b	"	"	" 122J	2

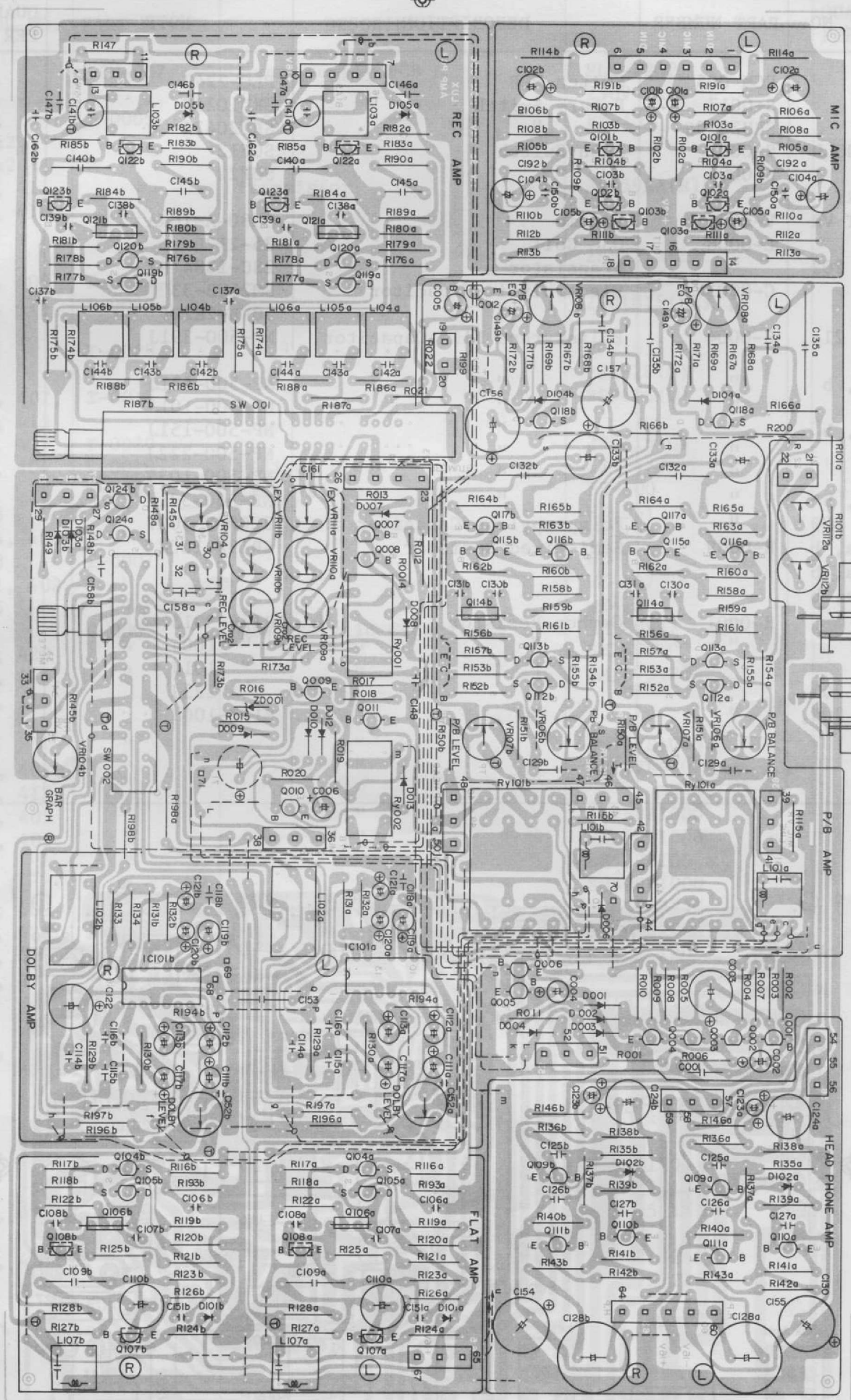

Switch PCB

SYMBOL NO.	PART NUMBER	DESCRIPTION	NOTE	QUANTITY PER UNIT
TIMER	PCM-005	Switch PCB	PLC-2242	1
BIAS	S-0017	Rotary Switch	SRU1023N	1
PEAK HOLD	SRU2043S	"	SRU2043S	1
RESET	S-0001	Push Switch	SUF12	1
MEMORY	S-0004	"	SUF22	1
OUTPUT VR	V-0006	Volume	GM80-A-10KA	1
L201	L-0008	OSC Coil	25-2126	1
Q201, 202		Transistor	2SC-1384 (R)	2
C201	C-0003	Electrolytic Capacitor	SM25VB-33	1
C210	"	"	50VB-2R2BP	1
C202, 211, 212	C-0004	Polystyrene Film Capacitor	NP-500-391J	3
C205a, b	"	"	NP-500-471J	2
C213	"	"	NP-500-101J	1
C204a, b	"	"	NP-500-151J	2
C208	"	"	NP-500-222J	1
C207	"	"	NP-500-1035	1
C203a, b	"	"	NP-500-331J	2
C206, 209	"	Polypropylene Capacitor	2200PF 500V	2
VR201a, b	R-0009	Semi-fixed Resistor	SR19R-100K	6
VR202a, b				
VR203a, b				
R207	R-0001	Carbon Resistor	R1/4-331J	1
R202	"	"	" 100J	1
R208	"	"	" 101J	1
R206, 203	"	"	" 223J	2
R204, 205, 201	"	"	R1/3-100J	3

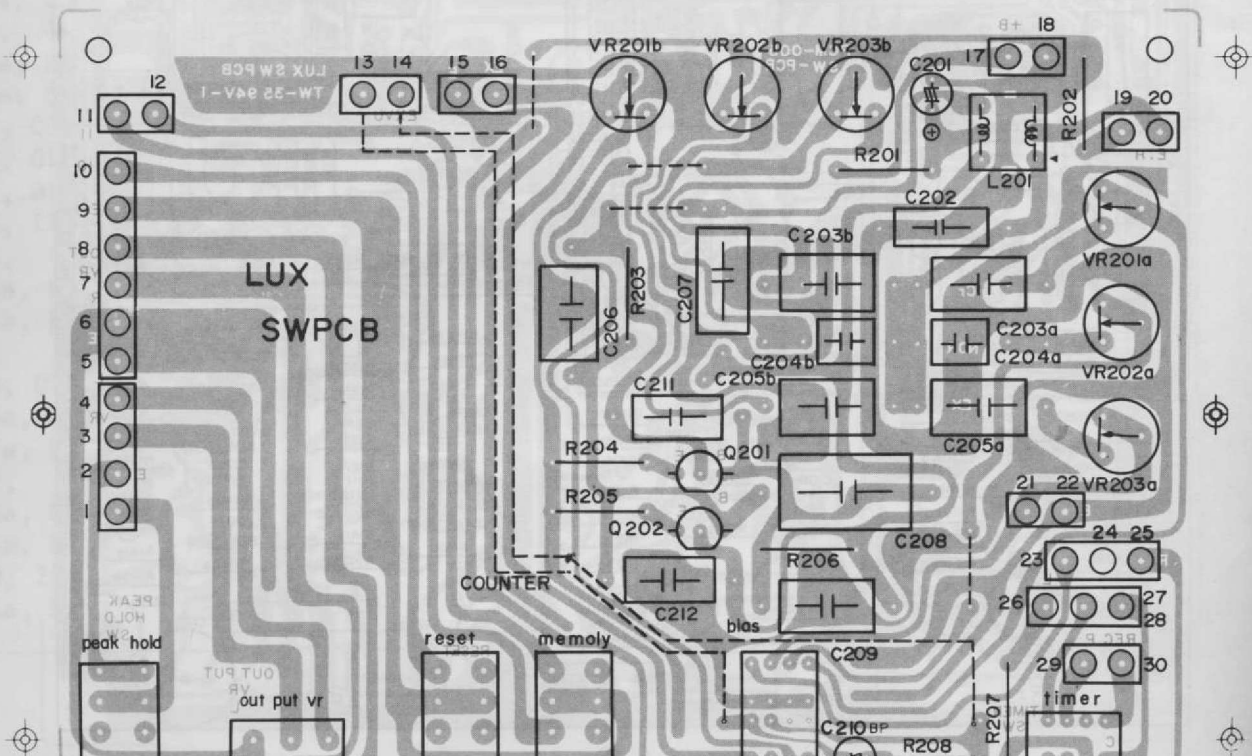



Power Supply PCB

SYMBOL NO.	PART NUMBER	DESCRIPTION	NOTE	QUANTITY PER UNIT
	PCM-007	Power Supply PCB	PLC-2242	1
		Fuse	250V 1AT	1
D401, 402x2, 403x2	T-0005	Diode	RB-152	5
Q403, 411, 414, 416, 419		Transistor	2SD592A(R)	5
Q405		"	2SB621A(R)	1
Q408, 409	T-0025	"	2SC945(P.Q)	2
Q402, 413, 418	T-0027	"	2SC1815(BL)	3
Q405	T-0028	"	2SC1015(Y)	1
Q401		"	2SB628(Q)	1
Q404, 407, 410, 415	T-0018	"	2SD608(Q)	4
Q412, 417	T-0020	"	2SB618(Q)	2
Q405, 404	T-0010	Silicon Diode	1S-2473	2
D407	T-0007	Zener Diode	BZ-100	1
ZD408	"	"	WZ-061	1
ZD404, 406	"	"	WZ-125	2
ZD403	T-0007	"	WZ-135	1
ZD401, 402	"	"	WZ-157	2
ZD405	"	"	WZ-110	1
C410	C-0003	Electrolytic Capacitor	SM16VB47	1
C415, 420	"	"	SM16VB100	1
C417, 414, 416, 419, 422	"	"	SM16VB470	5
C421	"	"	SM16VB1000	1
C406, 408, 412, 413	"	"	SM25VB470	4
C404, 405	"	"	SM25VB1000	2
C402, 403	"	"	SM35VB1000	2
C401	"	"	SM50VB100	1
C411	"	"	SM50VB1000	1
C407, 409	C-0002	Polyester Film Capacitor	AMS50-224K	2
R417, 426	R-0007	Metal Oxide Film Resistor	RS1BFSR22J	2
R404, 406, 415, 421	"	"	RS1BFS1R0J	4
R418	R-0008	"	RS1BFS-102J	1
R423	"	"	RS2BFS-181J	1
R401, 402	"	"	RS2BFS-620J	2
		Fuse Holder		2
	YM-0155	Heat Sink 3002		1
		Pan Head Screw	+ M3 x 8	9
		Hexagon Nut	M3	9
R408	R-0001	Carbon Resistor	RI/4-100J	1
R425		"	" 181J	1
R403, 405, 419		"	" 561J	3
R407, 427		"	" 102J	2
R416		"	" 272J	1
R411		"	" 562J	1
R412~ 414, 409		"	" 103J	4
R410		"	" 333J	1
R422		"	" 182J	1

Power Supply PCB

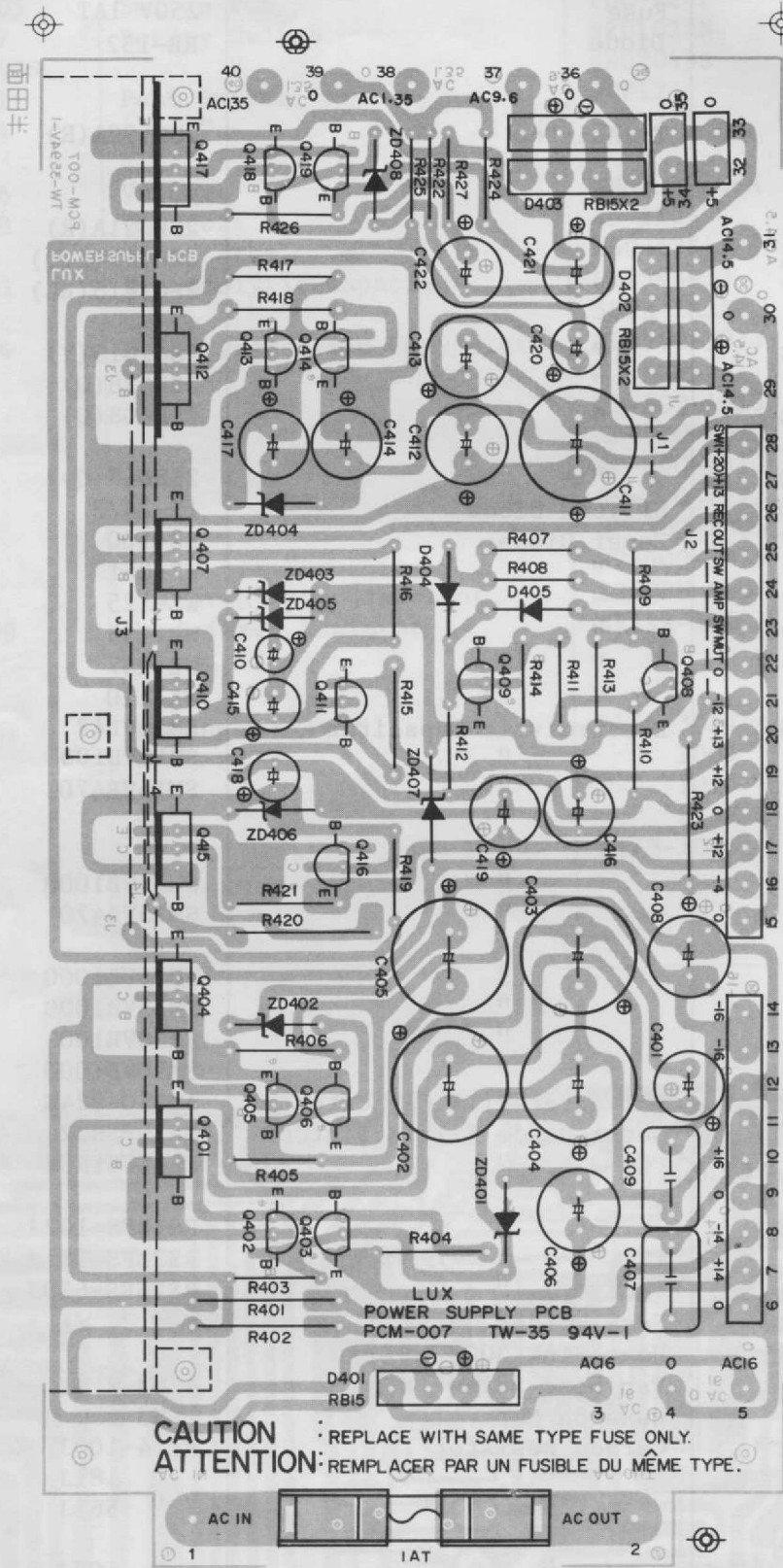

Power Supply PCB

Digital PCB

SYMBOL NO.	PART NUMBER	DESCRIPTION	NOTE	QUANTITY PER UNIT
	PCM-002	Digital PCB		1
IC303, 309	IC-0001	IC	74LS00N	2
IC307, 310, 317~320		"	HD74LS03P	6
IC305, 308, 321	IC-0002	"	74LS04N	3
IC316	IC-0003	"	74LS08N	1
IC306,	IC-0004	"	74LS09N	1
IC322	IC-0010	"	DM74LS47N	1
IC302	IC-0010	"	DM74LS74N	1
IC315	IC-0005	"	74LS175N	1
IC311~314	IC-0009	"	DM74LS192N	4
IC304	IC-0007	"	MM74C04N	1
IC301	IC-0012	"	NJM2901N	1
Q301~304	T-0028	Transistor	2SA1015(Y)	4
Q305, 306	T-0021	"	2SC945(P.Q)	2
C318	C-0004	Polystyrene Film Capacitor	NR-50-562J	1
C316	C-0003	Electrolytic Capacitor	SM6.3VB220	1
C311, 312 314	"	"	SM16VB10	3
C310	"	"	SM50VB1	1
C302	"	"	16VB-4.7BP	1
C305	"	"	SM25VB4R7	1
C304	"	"	SM50VB2R2	1
C330, 317, 313	C-0012	Ceramic Capacitor	DD600BC104Z12V19	3
C306, 308, 309, 315, 319, 320	"	"	DD350.950BC103Z 50V20	6
C301	"	"	DD107B332K50V02	1
C321~324, 326, 328, 329	C-0015	"	DD104B101K	7
C303, 307	"	"	DD104B102K50V02	2
D301~305	T-0010	Silicon Diode	1S-2473	5
RA303	R-0006	Resistance Networks	RMA3-151J	1
RA304	"	"	RMA4-151J	1
RA301	"	"	RMA4-392J	1
RA302	R-0005	"	RM4-222J	1
RA305	"	"	R4-223J	1
R339, 311	R-0002	Carbon Resistor	R25-100J	2
R302		"	" 820J	1
R318, 344		"	" 390J	2
R303		"	" 221J	1
R362, 363, 347, 348, 223, 322, 301, 316, 353, 331, 332, 312		"	" 102J	12
R307		"	" 822J	1
R306, 308, 341, 335, 355, 312, 313		"	" 103J	7
R310, 315, 319, 320, 328, 329,		"	" 223J	15

SYMBOL NO.	PART NUMBER	DESCRIPTION	NOTE	QUANTITY PER UNIT
333, 337, 338, 343, 345, 352, 354, 358, 359 R350, 351, 324 ~ 327 R357 R304, 305 349, 321 R340, 334 R356 R336, 342 R317 R309 R346 R360, 361	R-0002	Carbon Resistor	" 104J " 184J " 224J R25-274J " 394J " 824J " 561J " 105J " 333J " 331J	6 1 4 2 1 2 1 1 1 1 2





EXPLODED VIEW (B)  
K-12

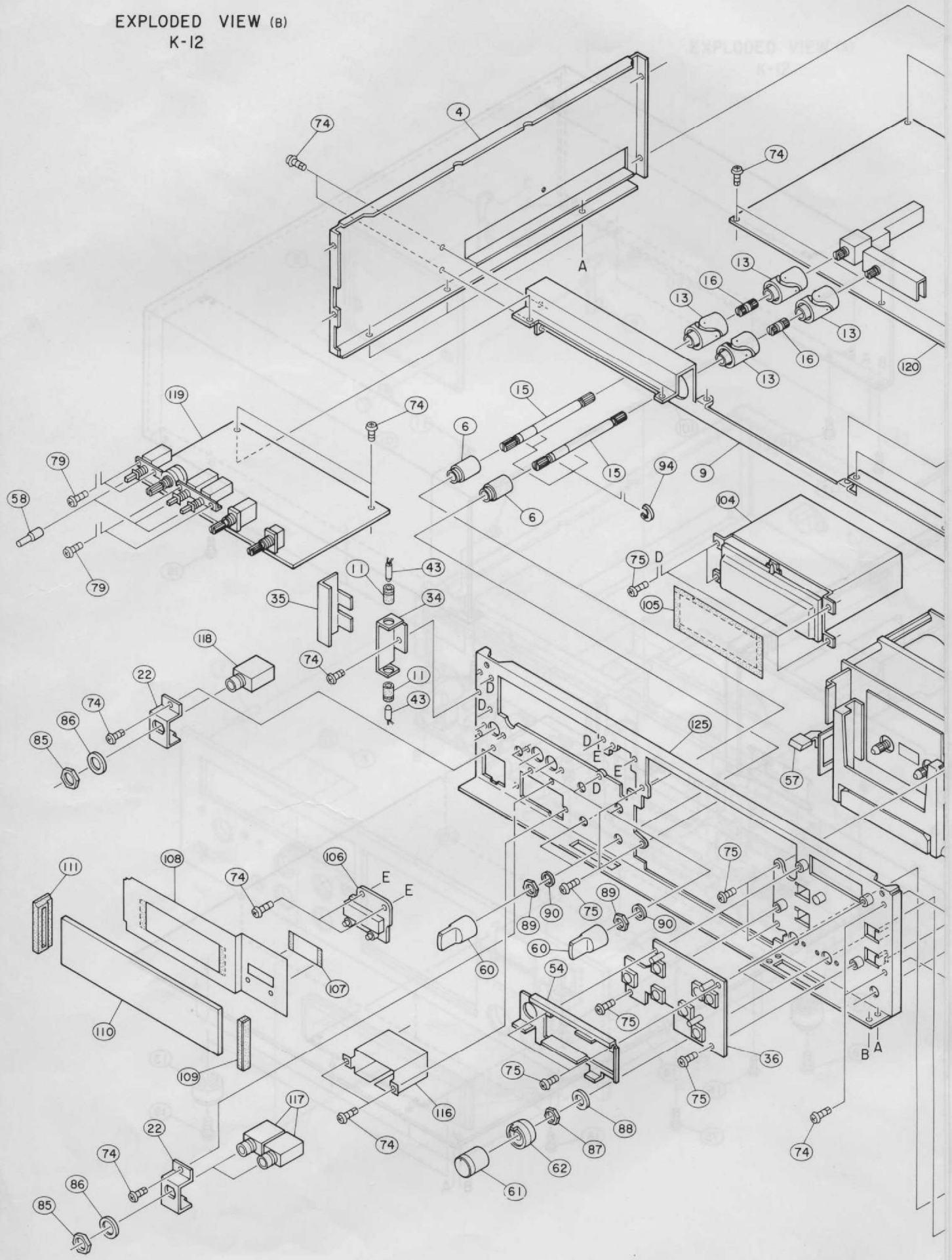

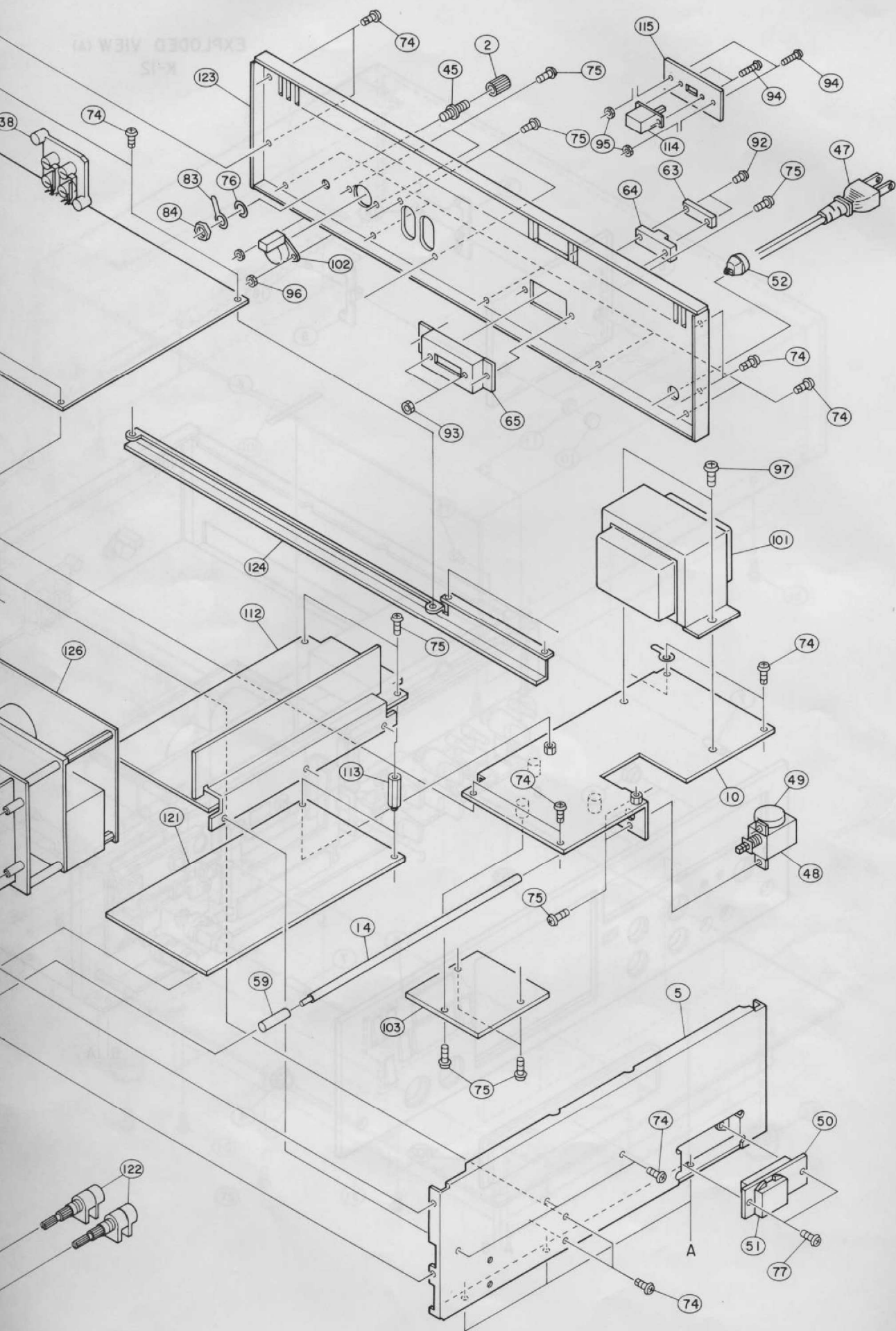



EXPLODED VIEW (A)  
K-12

EXPLODED VIEW (A)  
K-12

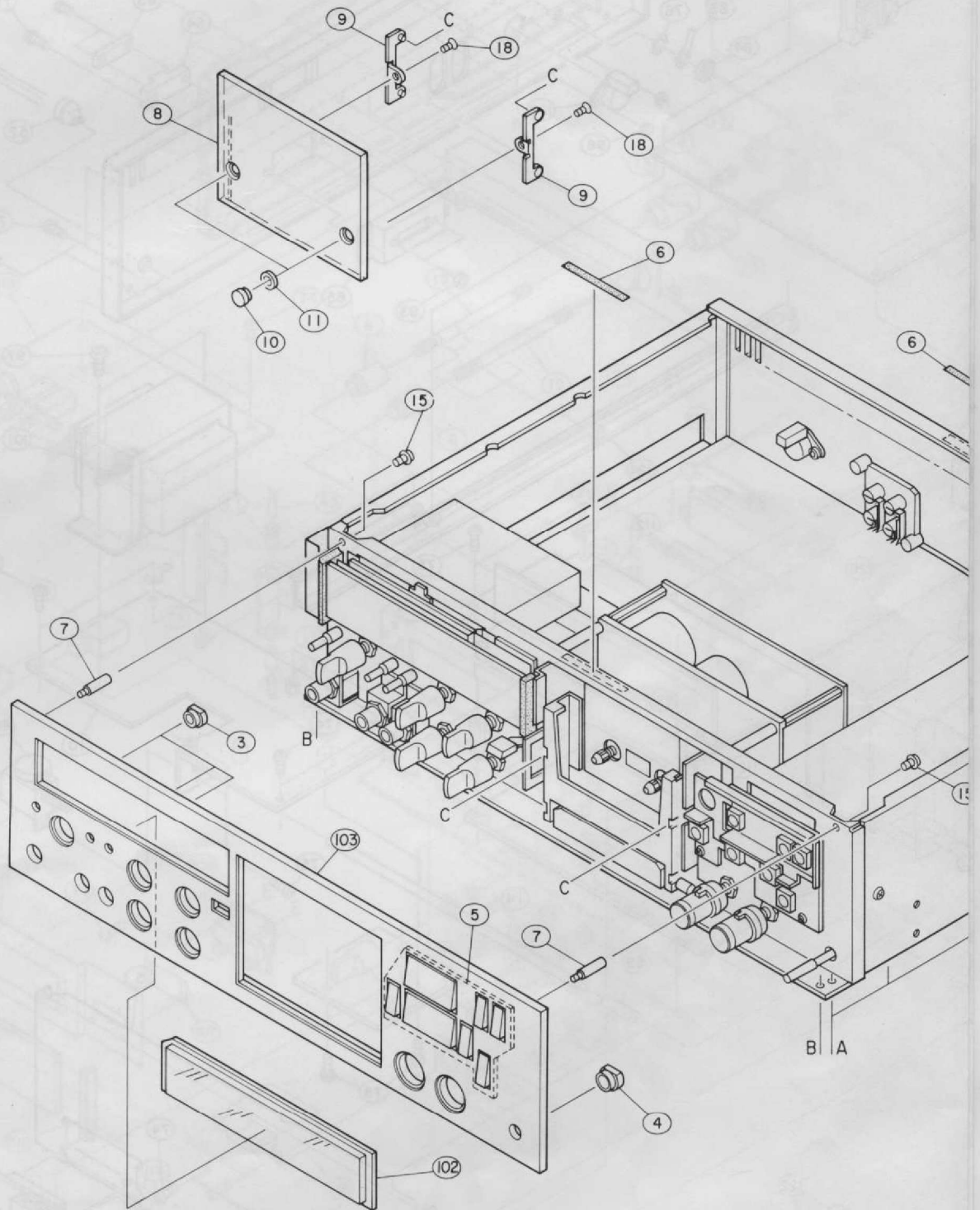

EXPLODED VIEW (a)  
K-12

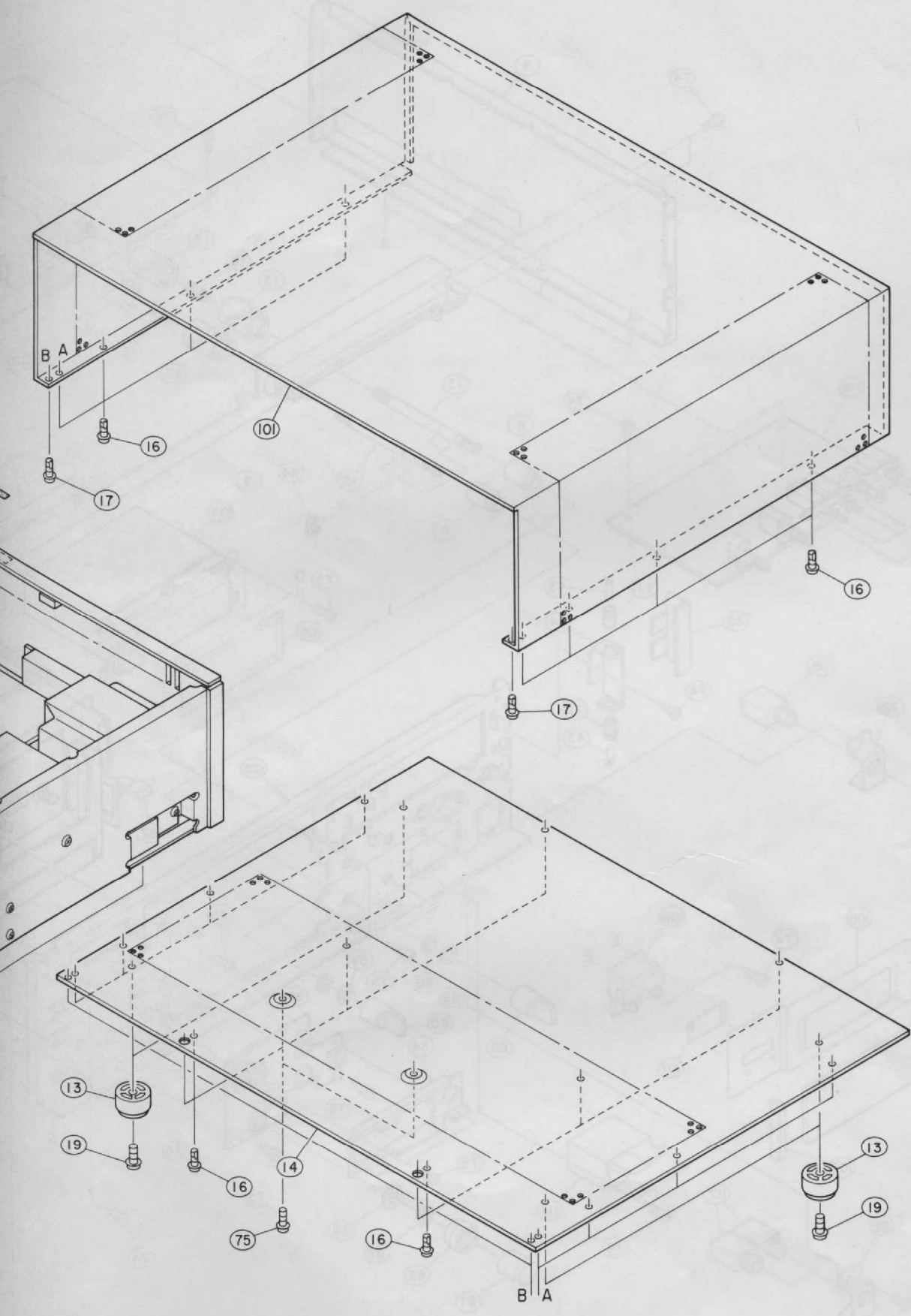

Exploded View & Optional Parts List

SYMBOL NO.	PART NUMBER	DESCRIPTION	QTY
------------	-------------	-------------	-----

1	1066	Protector 1076	1
2	10-3611	Protector 1066	1
3	10-4127	Knob Set 1061	1
4	10-4299	Support Element 1061	1
5	10-4321	Stand 1005	1
6	10-4323	Protector 1065	1
7	10-4167	Protector 1065	1
8	10-4169	Protector 1065	1
9	10-4169	Protector 1065	1
10	10-4169	Protector 1065	1
11	10-4169	Protector 1065	1
12	10-4169	Protector 1065	1
13	10-4169	Protector 1065	1
14	10-4169	Protector 1065	1
15	10-4169	Protector 1065	1
16	10-4169	Protector 1065	1
17	10-4169	Protector 1065	1
18	10-4169	Protector 1065	1
19	10-4169	Protector 1065	1
20	10-4169	Protector 1065	1
21	10-4169	Protector 1065	1
22	10-4169	Protector 1065	1
23	10-4169	Protector 1065	1
24	10-4169	Protector 1065	1
25	10-4169	Protector 1065	1
26	10-4169	Protector 1065	1
27	10-4169	Protector 1065	1
28	10-4169	Protector 1065	1
29	10-4169	Protector 1065	1
30	10-4169	Protector 1065	1
31	10-4169	Protector 1065	1
32	10-4169	Protector 1065	1
33	10-4169	Protector 1065	1
34	10-4169	Protector 1065	1
35	10-4169	Protector 1065	1
36	10-4169	Protector 1065	1
37	10-4169	Protector 1065	1
38	10-4169	Protector 1065	1
39	10-4169	Protector 1065	1
40	10-4169	Protector 1065	1
41	10-4169	Protector 1065	1
42	10-4169	Protector 1065	1
43	10-4169	Protector 1065	1
44	10-4169	Protector 1065	1
45	10-4169	Protector 1065	1
46	10-4169	Protector 1065	1
47	10-4169	Protector 1065	1
48	10-4169	Protector 1065	1
49	10-4169	Protector 1065	1
50	10-4169	Protector 1065	1
51	10-4169	Protector 1065	1
52	10-4169	Protector 1065	1
53	10-4169	Protector 1065	1
54	10-4169	Protector 1065	1
55	10-4169	Protector 1065	1
56	10-4169	Protector 1065	1
57	10-4169	Protector 1065	1
58	10-4169	Protector 1065	1
59	10-4169	Protector 1065	1
60	10-4169	Protector 1065	1
61	10-4169	Protector 1065	1
62	10-4169	Protector 1065	1
63	10-4169	Protector 1065	1
64	10-4169	Protector 1065	1
65	10-4169	Protector 1065	1
66	10-4169	Protector 1065	1
67	10-4169	Protector 1065	1
68	10-4169	Protector 1065	1
69	10-4169	Protector 1065	1
70	10-4169	Protector 1065	1
71	10-4169	Protector 1065	1
72	10-4169	Protector 1065	1
73	10-4169	Protector 1065	1
74	10-4169	Protector 1065	1
75	10-4169	Protector 1065	1
76	10-4169	Protector 1065	1
77	10-4169	Protector 1065	1
78	10-4169	Protector 1065	1
79	10-4169	Protector 1065	1
80	10-4169	Protector 1065	1
81	10-4169	Protector 1065	1
82	10-4169	Protector 1065	1
83	10-4169	Protector 1065	1
84	10-4169	Protector 1065	1
85	10-4169	Protector 1065	1
86	10-4169	Protector 1065	1
87	10-4169	Protector 1065	1
88	10-4169	Protector 1065	1
89	10-4169	Protector 1065	1
90	10-4169	Protector 1065	1
91	10-4169	Protector 1065	1
92	10-4169	Protector 1065	1
93	10-4169	Protector 1065	1
94	10-4169	Protector 1065	1
95	10-4169	Protector 1065	1
96	10-4169	Protector 1065	1
97	10-4169	Protector 1065	1
98	10-4169	Protector 1065	1
99	10-4169	Protector 1065	1
100	10-4169	Protector 1065	1
101	10-4169	Protector 1065	1
102	10-4169	Protector 1065	1
103	10-4169	Protector 1065	1
104	10-4169	Protector 1065	1
105	10-4169	Protector 1065	1
106	10-4169	Protector 1065	1
107	10-4169	Protector 1065	1
108	10-4169	Protector 1065	1
109	10-4169	Protector 1065	1
110	10-4169	Protector 1065	1
111	10-4169	Protector 1065	1
112	10-4169	Protector 1065	1
113	10-4169	Protector 1065	1
114	10-4169	Protector 1065	1
115	10-4169	Protector 1065	1
116	10-4169	Protector 1065	1
117	10-4169	Protector 1065	1
118	10-4169	Protector 1065	1
119	10-4169	Protector 1065	1
120	10-4169	Protector 1065	1
121	10-4169	Protector 1065	1
122	10-4169	Protector 1065	1
123	10-4169	Protector 1065	1
124	10-4169	Protector 1065	1
125	10-4169	Protector 1065	1
126	10-4169	Protector 1065	1
127	10-4169	Protector 1065	1
128	10-4169	Protector 1065	1
129	10-4169	Protector 1065	1
130	10-4169	Protector 1065	1
131	10-4169	Protector 1065	1
132	10-4169	Protector 1065	1

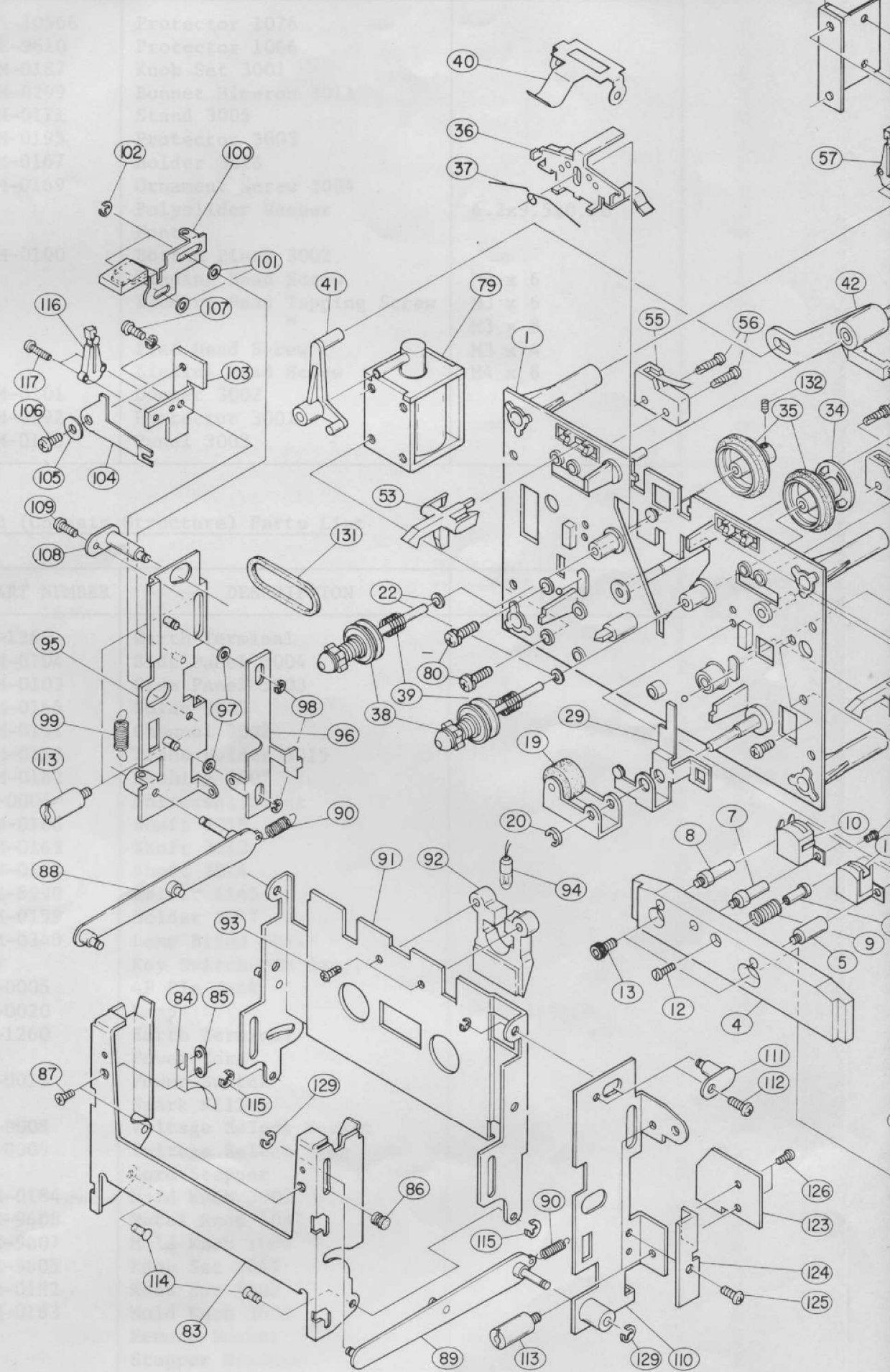

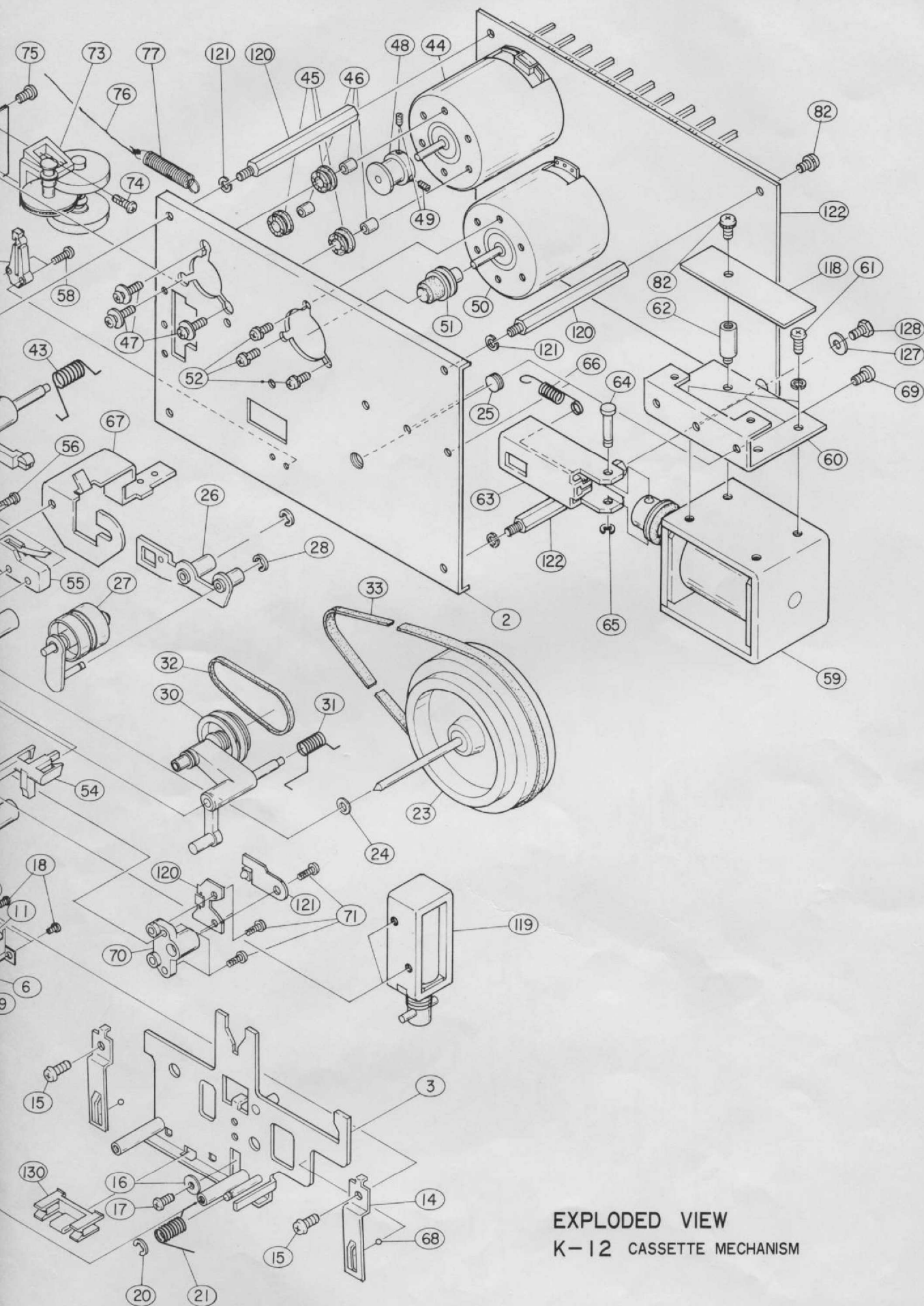

EXPLODED VIEW  
K-12 CASSETTE MECHANISM

Exploded View A (Exterior) Parts List

SYMBOL NO.	PART NUMBER	DESCRIPTION	NOTE	QUANTITY PER UNIT
3	SE-10566	Protector 1076		3
4	SE-9610	Protector 1066		1
5	YM-0187	Knob Set 3001		2
6	YM-0299	Bonnet Himeron 3011		2
7	YM-0171	Stand 3005		2
8	YM-0195	Protector 3003		1
9	YM-0167	Holder 3018		2
10	YM-0169	Ornament Screw 3004		2
11		Polyslider Washer	6.2x9.5x0.5t	2
13		Foot		4
14	YM-0100	Bottom Plate 3002		1
15		Binding Head Screw	M3 x 6	2
16		Binding Head Tapping Screw	M3 x 6	18
17		"	M3 x 8	2
18		Flat Head Screw	M3 x 4	2
19		Binding Head Screw	M4 x 8	4
101	YM-0101	Bonnet 3002		1
102	YM-0192	Protector 3001		1
103	YM-0185	Panel 3003		1

Exploded View B (Chassis Structure) Parts List

SYMBOL NO.	PART NUMBER	DESCRIPTION	NOTE	QUANTITY PER UNIT
2	A-1269	Earth Terminal		1
4	YM-0104	Side Panel 3004		1
5	YM-0103	Side Panel 3003		1
6	YM-0165	Guide 3005		2
9	YM-0151	Channel 3002		1
10	YM-0153	Trans Holder 3015		1
11	YM-0162	Bushing 3007		2
13	Z-0004	Universal Joint		4
14	YM-0166	Shaft 3015		1
15	YM-0163	Shaft 3013		2
16	YM-0164	Shaft 3014		2
22	SE-8990	Holder 1145		3
34	YM-0159	Holder 3017		1
35	YM-0340	Lamp Blind 3051		1
36		Key Switch PCB Assy.		1
38	A-0005	4P Pin Jack		1
43	A-0020	Lamp	C-2F 14V100mA	2
45	A-1260	Earth Terminal		1
47		Power Cord		1
48	S-0015	Power Switch		1
49		Spark Killer		1
50	A-0008	Voltage Select Socket		1
51	A-0009	Voltage Select Plug		1
52		Cord Stopper		1
57	YM-0184	Mold Knob 3002		1
58	SE-9608	Metal Knob 1097		3
59	SE-9607	Mold Knob 1089		1
60	SE-9605	Knob Set 1047		5
61	YM-0182	Knob Set 3002		2
62	YM-0183	Mold Knob 3003		2
63		Remote Socket	S-1612A-ST	1
64		Stopper Bracket		1

SYMBOL NO.	PART NUMBER	DESCRIPTION	NOTE	QUANTITY PER UNIT
74		Binding Head Tapping Screw	M3 x 6	2
75		Binding Head Screw	M3 x 6	4
76		Toothed Lock Washer	M6	2
77		Binding Head Tapping Screw	M3 x 8	6
78		Sems Screw		7
79		"		8
83		Egg Terminal	6φ	1
84		Nut	M6	1
85		Volume Nut	M12	1
86		Volume Washer	M12	1
87		Volume Nut	M9	1
88		Volume Washer	M9	1
89		Volume Nut	M7	1
90		Volume Washer	M7	1
92		Binding Head Screw	M2.6 x 8	1
93		Nut	M2.6	1
97		Binding Head Screw	+ M4 x 6	4
101		Power Trans		1
102	A-0002	DIN Socket		1
103		Fuse PCB Assy		1
104	M-0003	Meter	LB100-L24B LB100-L24A(Old Type)	1
105	YM-0278	Meter Filter 3034		1
106		Counter PCB Assy.		1
107	YM-0287	Counter Blind 3005		1
108	YM-0363	Meter Filter 3034		2
109	YM-0320	Bushing 3016		1
110	YM-0170	Edge Light Acryl		1
111	YM-0320	Bushing 3016		1
112		Power Supply PCB Assy		1
113	YM-0157	Stand 3004		2
114		Slide Switch	SS22070-5	1
115	YM-0347	Name Plate 3005		1
116	YM-0158	Shield Plate		1
117	A-0015	Mike Jack		2
118	A-0015	Headphone Jack		1
119		Switch PCB Assy		1
120		AMP PCB Assy		1
121		Digital PCB Assy		1
122	V-0007	Volume	DM20A-20KA	1
	V-0005	Volume	DM20A-10KA	1
123	YM-0001	Back Panel 3001		1
124	YM-0152	Channel 3003		1
125	YM-0150	Sub Panel 3002		1
126		Cassette Deck Assy		1

Cassette Mechanism Parts List

SYMBOL NO.	PART NUMBER	DESCRIPTION	NOTE	QUANTITY PER UNIT
1	TA4-16639	Chassis C Assy		1
2	T4-16758	Chassis S		1
3	TA3-2063	Head Base Assy		1
4	T4-16645	Head Plate		1
5	T4-16646	R/P Head Hold Shaft		1
6	T4-16647	R/P Head Aligned Shaft		1
7	T4-16648	E Head Holder Shaft		1
8	T4-17421	" (B)		1
9	T4-5067	Spring, Azimuth		1
10	T4-28319	Erase Head		1
11	T4-28373	R/P Head		1
12		Flat Head Screw	- M2 x 10	1
13	Z4-5561	Hexagon Socket Headless Set	+ M3 x 8	2
14	T4-15699	Spring, Head Base Screw		2
15		Tap Tite	+ M3 x 5	2
16	Z4-5521	Plain Washer	+ 2.6 x 0.4	1
17		Tapping Screw	+ M2.6 x 5	1
18	Z4-5032	Pan Head Screw	+ M2 x 3	4
19	TA4-16610	Pinch Roller Arm Assy.		1
20	Z4-1414	E Type Washer	+ 2.5 x 0.4 <sup>t</sup>	2
21	T4-15740	Pinch Roller Spring		1
22	Z4-5160	Polyslider Washer		3
23	TA4-16836	Flywheel Assy.		1
24	Z4-5128	Polyslider Washer	+ 2.5 x $\phi$ 5 x 0.25 <sup>t</sup>	1
25	T4-15703	Fly Wheel Adjust Screw		1
26	TA4-15648	F.R. Idler Plate Assy.		1
27	TA4-15652	F.R. Idler Assy.		1
28	Z4-1403	E Type Washer	1.5 x 0.4 <sup>t</sup>	1
29		Pause Lever Assy.		1
30	TA4-15750	Tention Arm Assy.		1
31	T4-15745	Tension Pulley Spring		1
32	T4-15697	Square Belt		1
33	T4-15698	Flat Belt		1
34	T4-15675	FF. Reel Table		2
35	T4-16721	Reel Table Revolving Plate		1
36	T4-16759	Brake		1
37	T4-15737	Brake Spring		1
38	TA4-15748	FF. Reel Bearing Assy.		2
39	T4-12541	Back Tension Spring		2
40	T4-15696	Cassette Push Spring		1
41	T4-15700	Brake Joint Lever		1
42	T3-1962	Brake Lever		1
43	T4-15738	Brake Lever Spring		1
44	T4-18355	FG Motor	MMX - 5A2 LSA	1
45	T4-15701	Motor Floating Gum		3
46	T4-15702	Motor Kraan		3
47	Z4-5069	SEMS Screw	+ M2.6 x 7	3
48	T4-15705	Pulley, Motor		1
49	Z4-5977	Slotted Set Screw (Cone	- M2 x 6	2
50	T4-28002	Motor Point)	MHN5	1
51	TA4-15706	F.R. Motor Pulley Assy		1
52	Z4-5061	SEMS Screw	+ M2.6 x 4	3
53	T4-15701	REC Switch Lever		1
54	T4-16656	Half Switch Lever		1
55	T4-28004	Micro SW	SSLIN	2
56	Z4-5974	Tapping Screw	+ M2 x 12	4
57	T4-28317	Leaf Switch	101G	1

SYMBOL NO.	PART NUMBER	DESCRIPTION	NOTE	QUANTITY PER UNIT
58	Z4-5037	Tapping Screw	+ M2 x 8	2
59	T4-19000	Plunger	P-177	1
60	T4-15691	Plunger Holder Plate		1
61	Z4-5081	SEMS Screw	+ M3 x 8	3
62	T4-16852	PCB Holder Shaft		1
63	T4-15709	Play Joint Lever		1
64	T4-15710	Plunger Pin		1
65	Z4-1414	E Type Washer	Φ25 x 0.4t	1
66	T4-15736	Head Base Spring		1
67	T3-1968	Head Base Driving Plate		1
68	Z4-6304	Steal Ball	Φ2	6
69	Z4-5731	Tap Tite	+ M3 x 5	2
70	T4-16700	Photo Transistor Holder		1
71	Z4-5054	Tapping Screw	+ M2 x 6	2
72	T4-16722	Damper Holder Plate		1
73	T4-16863	"		1
74	Z4-5054	Tapping Screw	+ M2 x 6	2
75	Z4-5731	Tap Tite	+ M3 x 5	1
76	T4-16136	Damper Thread		1
77	T4-16865	Damper Spring		1
78	T4-28001	Plunger	P-10H-1	78
79	T4-28384	Plunger	P-157J-1	1
80	Z4-5006	Binding Head Screw	+ M2.6 x 4	2
81				
82	Z4-5081	SEMS Screw	+ M2.6 x 4	2
83	T3-2065	Cassette Holder		1
84	T4-16659	Cassette Plate Spring		2
85	T4-16850	Spring Holder Plate		4
86	YM-0298	Bushing - 3015		2
87	Z4-5774	Flat Head Screw	+ M2 x 4	4
88	TA4-16662	Link L Assy.		1
89	TA4-16667	Ling R Assy.		1
90	T4-16689	Link Return Spring		2
91	T3-2066	Mechanical Blind Plate		1
92	T4-16853	Cassette Light Lens		1
93		Pan Head Tapping Screw	+ M2 x 4	2
94		Lamp	T4.2 6V 100mA	1
95	TA3-2067	Link Holder (L) Assy.		1
96	T4-16679	Lock Cam.		1
97	Z4-5888	Polyslider Washer		2
98	Z4-1413	E Type Washer	Φ2 x 0.4 <sup>t</sup>	2
99	T4-16687	Lock Cam Return Spring		1
100	TA4-16675	Eject Lever Assy.		1
101	Z4-5888	Polyslider Washer	Φ3.1xΦ5.4x0.5 <sup>t</sup>	2
102	Z4-1413	E Type Washer		2
103	T4-16680	Prevented Lever Holder		1
104	T4-16681	Eject Prevented Lever		1
105	T4-16682	Safety Lever Kraan		1
106	Z4-5663	Pan Head Screw	+ M2.6 x 6	1
107	Z4-5596	"	+ M2.6 x 3	1
108	TA4-16858	Adjusting Plate (A) Assy.		1
109		Pan Head Screw	+ M2.6 x 4	1
110	TA3-2069	Link Holder (R) Assy.		1
111	TA4-16860	Adjusting Plate (B) Assy.		1
112		Pan Head Screw		1
113	T4-16686	Mechanison Install Boss		4
114	T4-16685	Cassette Holder Shaft		2



SYMBOL NO.	PART NUMBER	DESCRIPTION	NOTE	QUANTITY PER UNIT
115	Z4-1413	E Type Washer	$\phi 2 \times 0.4t$	2
116	T4-28317	Toggle Switch	101G	1
117		Pan Head Screw	+ M2 x 8	2
118	T4-16964	Plunger Cushion		1
119	T4-28316	Solenoid	P157J-1	1
120	T4-16593	P.C.B. Holder Shaft		2
121	Z4-5162	Spring Washer		4
122	T4-16655	P.C.B. Holder Shaft		2
123		Hot Transistor PCB Assy.		1
124	YM-0130	Holder 3013		1
125		Binding Head Screw	+ M2.6 x 4	1
126		Binding Head Screw	+ M2 x 3	2
127		Fiber Washer		2
128		Hexagon Head Bolt	+ M3 x 8	2
129		E Type Washer	$\phi 2.5$	1
130	T4-5067	Bind Metal		1

QUANTITY	PART NUMBER	DESCRIPTION	PART NUMBER	SYMBOL NO.
		<b>SPECIFICATIONS</b>		
	<b>Heads:</b>	2 heads (sendust) Record/Playback Head x 1 Erase Head x 1		
	<b>Drive Motor:</b>	2 motors FG servo motor x 1 Electronic governor motor x 1		
	<b>Wow &amp; Flutter:</b>	no more than 0.04% (W.R.M.S.)		
	<b>Signal-to-Noise Ratio:</b>	better than 60dB (DOLBY*OFF) ..... metal tape better than 69dB (DOLBY ON) ..... metal tape better than 55dB (DOLBY OFF) ..... CrO <sub>2</sub> tape better than 65dB (DOLBY ON) ..... CrO <sub>2</sub> tape better than 53dB (DOLBY OFF) ..... LH tape better than 63dB (DOLBY ON) ..... LH tape		
	<b>Frequency Response:</b>	30 - 20,000Hz ±3dB (metal tape) 30 - 18,000Hz ±3dB (CrO <sub>2</sub> tape) 30 - 16,000Hz ±3dB (LH tape)		
	<b>Overall Distortion:</b>	no more than 1.2% (LH tape, 1kHz, 0dB)		
	<b>Real Analyzed Distortion:</b>	no more than 0.3% (LH tape, 1kHz, 0dB)		
	<b>Input Sensitivity:</b>	line in; 100 mV mic.; 0.25 mV (recommended impedance: 600 ~ 10k ohms) DIN.; 2 mV/1k ohms		
	<b>Output Level:</b>	line in; 580 mV headphone 1 mW (8 ohms load)		
	<b>Additional Features:</b>	REC. MUTE function, Digital Tape Counter, 3-position Bias/Equalizer Selector (CrO <sub>2</sub> , normal, EX), Plasma Peak Indicator with Peak Hold function, Timer Recording/Playback function, Dolby Noise Reduction system, Headphone Jack, Remote Control (available with optional remote control box. In this case, auto-rewind and auto-play operations are feasible.)		
	<b>Dimensions:</b>	438(W) x 370(D) x 126(H)mm (17-1/4" x 14-9/16" x 4-31/32") (including Legs, Rear Protrusions & Knobs)		
	<b>Weight:</b>	Net 10.5 kgs (23.1 lbs.) Gross 12.0 kgs (26.4 lbs.)		

Specifications and appearance design subject to change without notice.

\*Dolby is the trademark of Dolby Laboratories, Inc.

82	24-10007	Link E Assy.		
83	24-10007	Link Return Spring		
84	24-10008	Mechanical Blind Plate		
85	24-10009	Cassette Light Lens		
86	24-10010	Pan Head Tapping Screw	+ 12 x 4	
87	24-10011	Lamp		
88	24-10012	Link Holder (L) Assy.		
89	24-10013	Lock Cam		
90	24-10014	Polyslider Washer		
91	24-10015	E Type Washer		
92	24-10016	Lock Cam Return Spring		
93	24-10017	Eject Lever Assy.		
94	24-10018	Polyslider Washer		
95	24-10019	E Type Washer		
96	24-10020	Prevented Lever Holder		
97	24-10021	Eject Prevented Lever		
98	24-10022	Safety Lever Spring		
99	24-10023	Pan Head Screw	+ 12.5 x 4	
100	24-10024	Pan Head Screw	+ 12.5 x 4	
101	24-10025	Adjusting Plate (R) Assy.		
102	24-10026	Pan Head Screw	+ 12.5 x 4	
103	24-10027	Link Holder (R) Assy.		
104	24-10028	Adjusting Plate (L) Assy.		
105	24-10029	Pan Head Screw		
106	24-10030	Mechanical Lever Assy.		
107	24-10031	Ejector Holder		



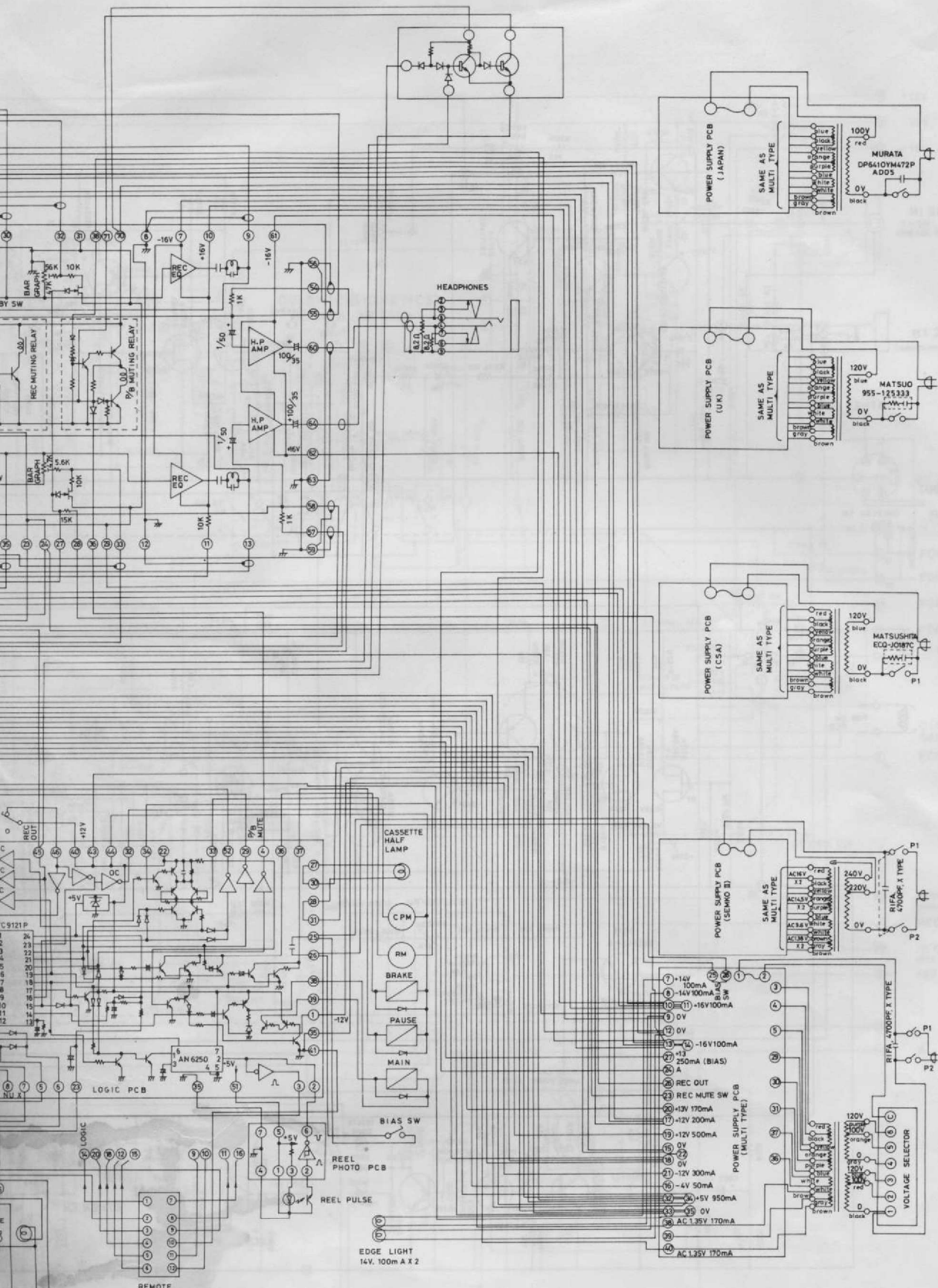

**CIRCUIT DIAGRAM K-12**



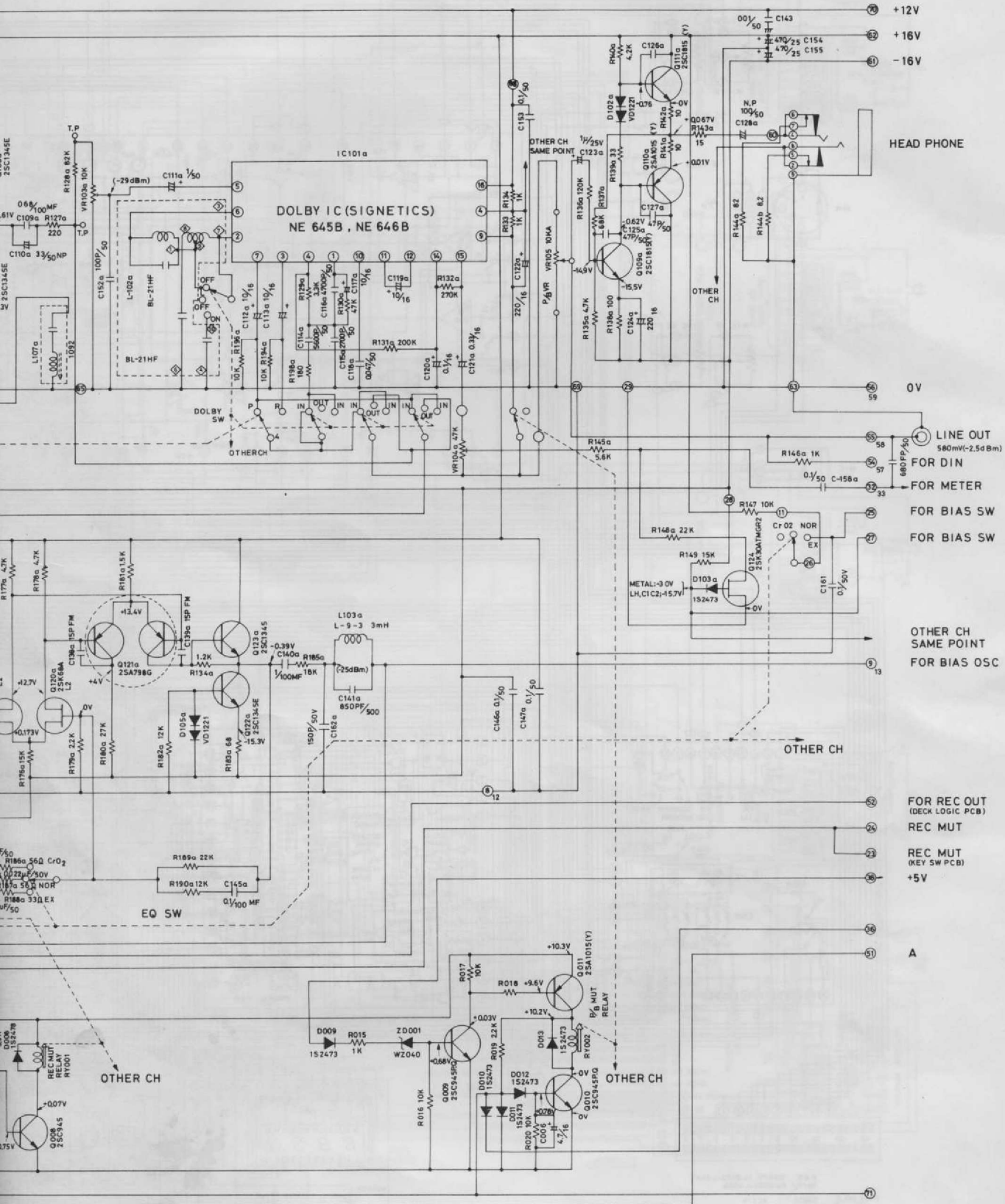

# AMPLIFIER CIRCUIT K-12

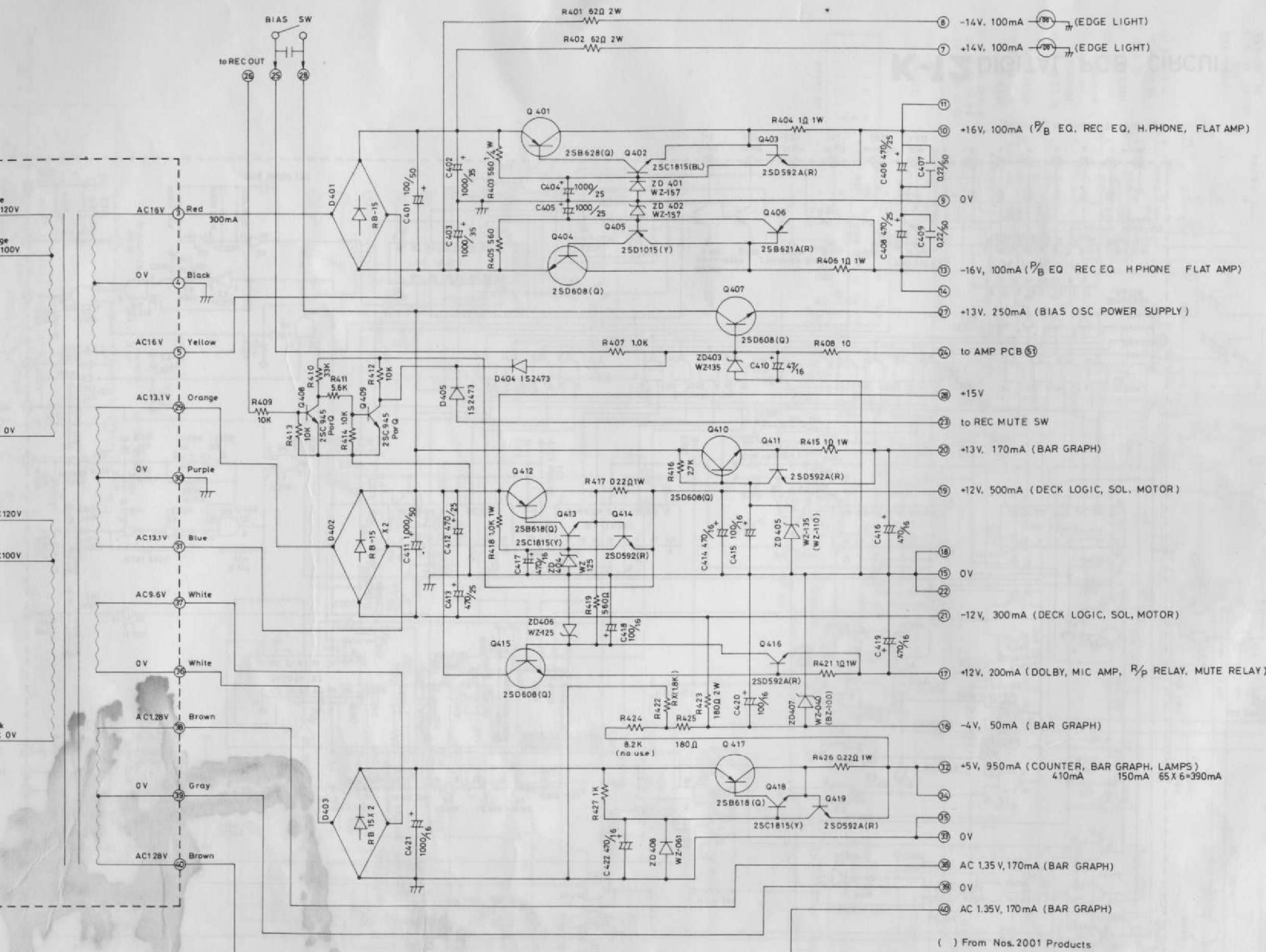

**K-12 POWER SUPPLY CIRCUIT**

( ) From Nos.2001 Products

(C)----- Ceramic Condenser  
(S)----- Styrol Condenser

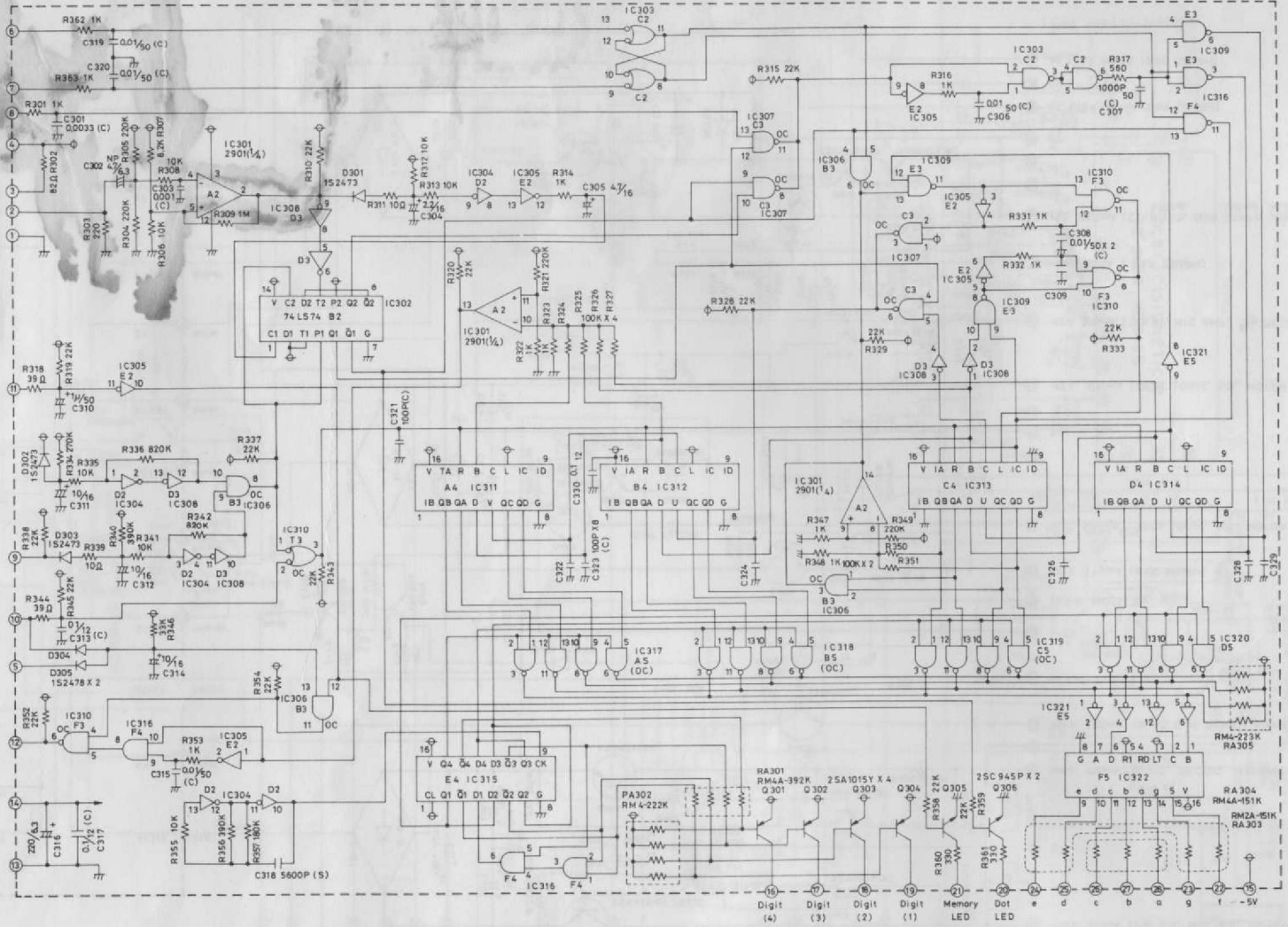

**K-12** DIGITAL PCB CIRCUIT



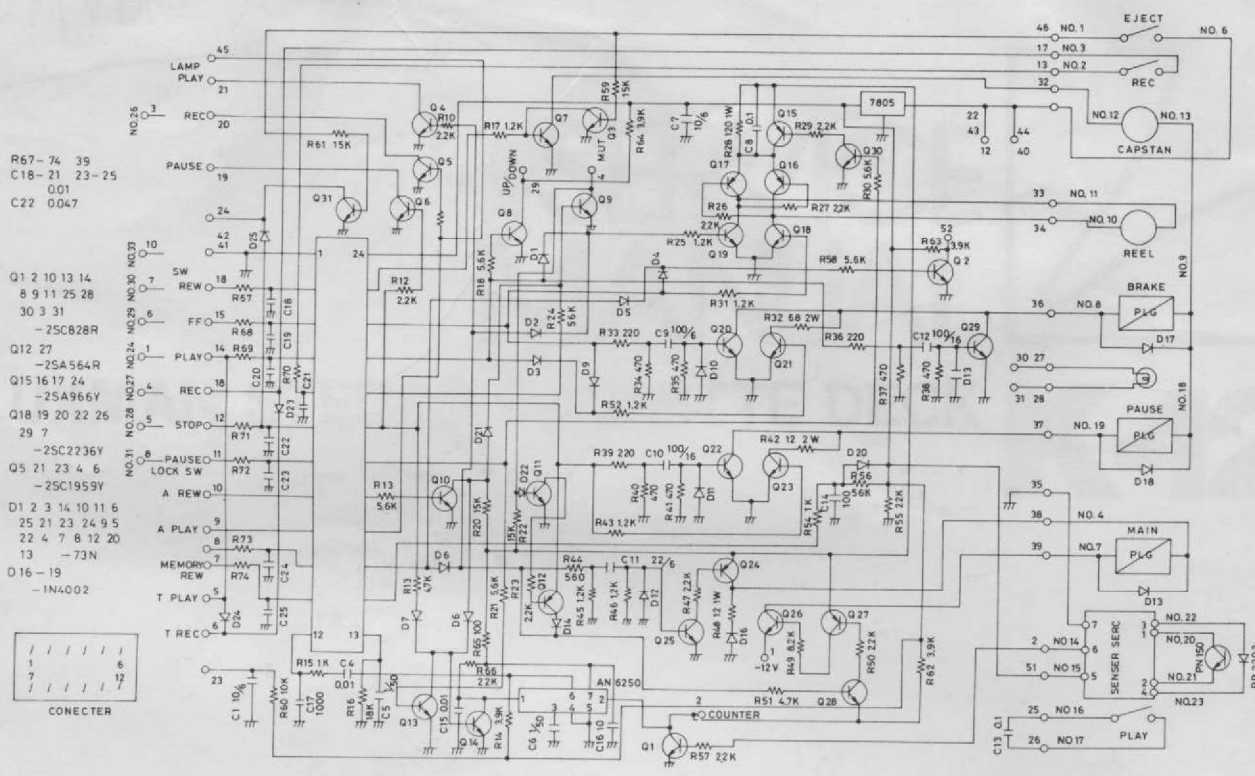

**K-12 CONTROL CIRCUIT**

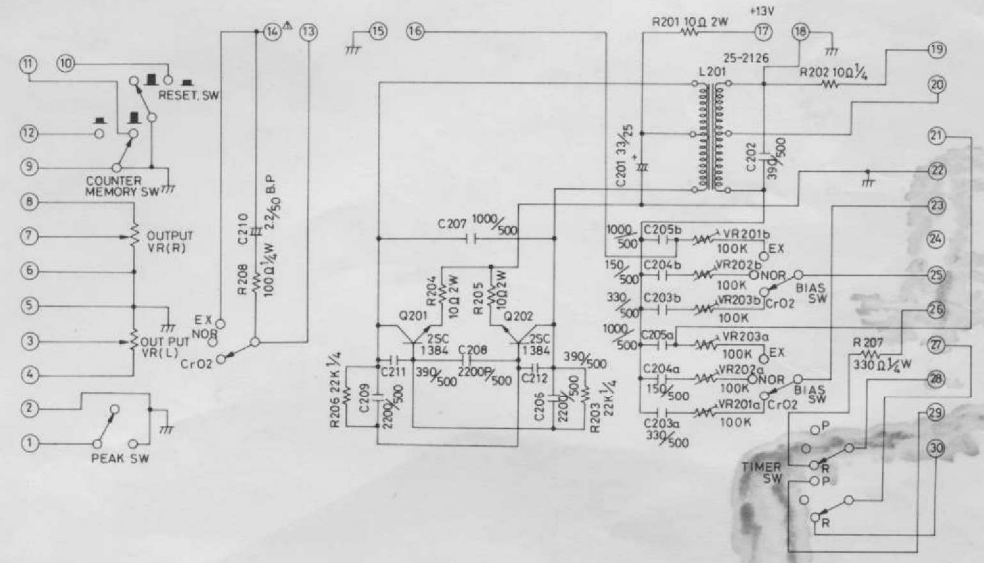

**K-12 SW PCB CIRCUIT**

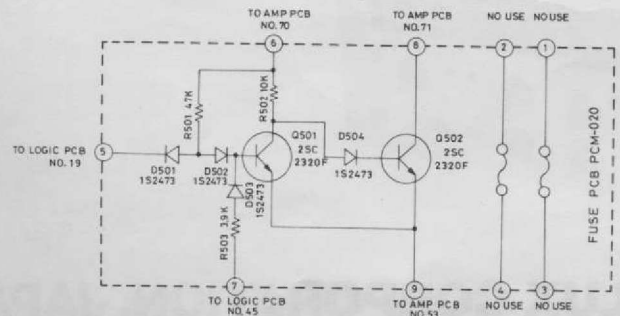

**K-12 PAUSE MUTING CIRCUIT**

**LUX CORPORATION, JAPAN**

1-1, 1-CHOME, SHINSENRI-NISHIMACHI, TOYONAKA-SHI, OSAKA  
PHONES: 06-834-2222 CABLE: LUXMAN TOYONAKA TELEX: J63694