

ULTIMATE HIGH FIDELITY STEREO COMPONENT

**QUINTON**

**M-4000**

**POWER AMPLIFIER**

**SERVICE MANUAL**



C I R C U I T   D E S C R I P T I O N

Emitter Follower Circuit

Output signals of a control amplifier etc. are led to the input terminals (MAIN IN) of this power amp, and level controlled at the input level control of a detent volume equivalent to the high-grade attenuator with 22 contact-points of 1dB decrement.

Then fed into the Emitter Follower circuit, which is, different from the ordinary one, composed by two transistors Q101 and Q102. The former is for emitter follower and the latter is for the constant current drive of the emitter follower of Q101. Signals are impedance-converted through this circuit, and therefore electrical isolation is made between the output stage of a control amp and the pre-driver circuit of this amplifier to eliminate interference between both circuits. Thus stable amplification with low distortion is attained.

Pre-Driver Circuit

Signals converted into low impedance at emitter follower circuit are then fed to the two-stage differential amplifier, a kind of balanced DC amplifying circuit, to meet voltage amplification. The differential amplifier is always stable against possible fluctuation of mains voltage and temperature drift, and has been widely used as Operational Amplifier with IC's in computers or measurement instruments etc. The two transistors Q301, Q302 for the 1st stage differential amplifier are arranged quite symmetrically, and the emitter of the both transistors are connected to (+) power supply through a common resistor. The base of Q301 accepts the input signal, while that of Q302 accepts the feed back signal. Due to adoption of the two transistors of the same standard, equivalent current is available at collector and emitter when the same signals are fed to the base of the both transistors. As emitter current for two pieces of resistors will flow through the emitter resistor, the emitter potential will rise up accordingly, which corresponds to negative feedback. On the other hand, if subtle (+) potential may appear at the speaker terminals by the drift of transistors caused by other factors but signals, for instance, the raise up of temperature, this (+) potential is led to the base of Q302 via the feedback circuitry, when (+) signal of the same phase will appear at the emitter resistor. In this case, the potential at the emitter resistor of Q301 varies to (+), which reduces the collector current to have (-) potential at collector. The voltage is amplified by the 2nd differential amplifier Q303 Q304, which makes the (+) potential stable at the speaker terminals, and makes it possible to keep balanced 0 potential.

The second differential amplifier operates same as the first one, though not perfectly symmetrical. The constant current drive by Q305 is applied, since this stage aims at voltage amplification. The emitter follower circuit is arranged annexed to the differential amplifier with a pair of Q306 and Q307 which electrically isolates the "Class A" operation at the differential stage and the "Class B" operation at the power amp stage. (Q306 is for the emitter follower and Q307 is for its constant current driving.) Therefore, impedance fluctuation caused by the speaker loads would not affect the pre-driver stage.

With this pre-driver stage, stable driving with low distortion is feasible up to high frequency range with smaller phase compensation comparing with conventional high power amplifiers. As for the power supply circuit for "Class A" operation section up to the differential stage, a real automatic voltage regulator is adopted to avoid bad influence which may possibly be caused by the fluctuation of AC mains voltage or the current fluctuation in the power amplifier section.

Bias Circuit

The adjustment of the quiescent current at the final stage is made by a thermal diode and the transistor Q401. These components directly touch the heat sink, and compensates the excessive heat and the temperature drift.

### Power Output Circuit

Adopted is a pure complementary push-pull circuit composed by the power transistors of NPN group and PNP group which are all specially developed for LUXMAN. In order to produce such a high power of 180W/ch, triple push-pull stages utilizing 6 power transistors designed for high power output are arranged at the final stage. And the push-pull stage utilizing driver transistor which are also exclusive for LUXMAN is arranged at the complementary driver stage. Thus sufficient driving of various type of the speaker system is feasible. With the M-4000, the total collector-dissipation of the power transistors in each channel is 450W, and the collector emitter breakdown voltage is 180V.

The power supply for the final stage and the complementary driver stage is quite independent for the left and right channels, which ensures the same power output at each channel whether both channels are driven or single channel is driven. But bear in mind that when the full power output is fed into 4-ohm loads, a slight difference may be possible due to the regulation of the commercial electric power.

### Protection Circuit

The OCL circuit, in which the speaker system is directly connected to the amplifier, is ideal in the point that the input signal is delivered most faithfully. But this circuit is always accompanied by the danger that any abnormal factors aroused in the amplifier will be delivered to the speaker system without barrier. On the other hand, electronic components will increase in its number in proportion with improvements of the circuit design, and it is hard to foresee every trouble that may happen, even if the most severe selection is made of the superior components. Necessity is here to have the protection circuits. The most important in the operation of the protection circuit is reliability and speed. Therefore the sensitivity should be as high as possible in the range of the safety operation.

The protection circuits of the M-4000 have to be designed not to be mis-functioned by the current of music reproduction signal. As to the over-current sensing, when excessive current, which may break the power transistors, appears, the current is once restrained electronically to keep the operation of the power transistors in the S.O.A. (Safe Operation Area). And in case the restraint time lasts over a certain time, the mains power is shut off by fuses.

Other protection circuits are;

# D.C.-Drift Sensing --- This protects the speaker system by cutting off the output when some +3V is detected at the speaker terminals. This also operates as the muting circuit which protects the speaker system from transient phenomena caused by the mains being turned on.

#Power Transistor Failure Sensing --- This shuts off the mains power when even one fuse of any power transistors is ruptured.

#Abnormal High Temperature Sensing --- This shuts off the mains power when the temperature at the heat sink is over 80°C under hard driving for a long time.

Thus the M-4000 is equipped with 4 protection circuits. One is for protection of speaker systems, and the other three are for protection of the amplifier.



P. B. LOCATION

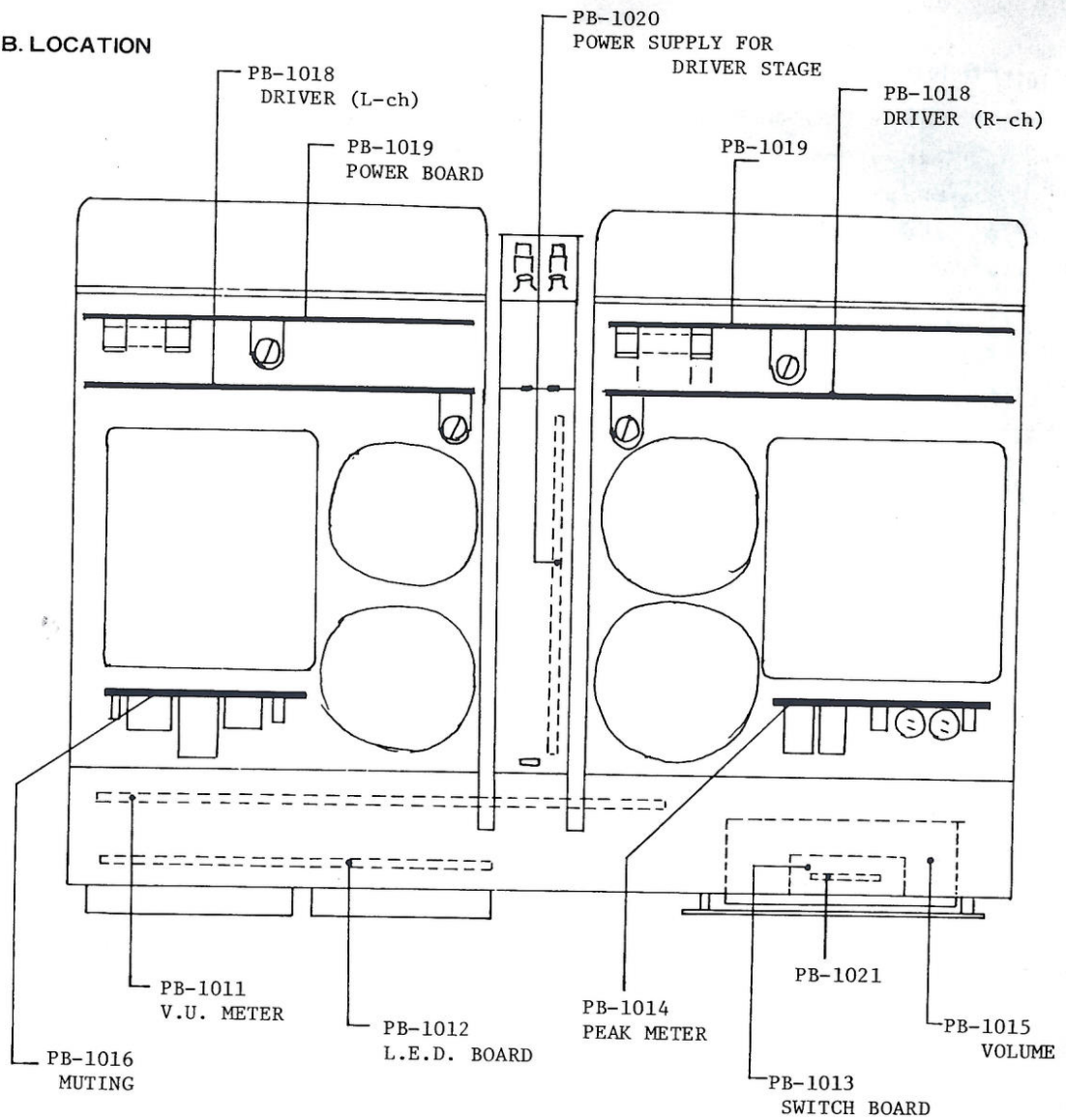

idle adjust and  
zero d.c. offset

ZERO D.C. OFFSET

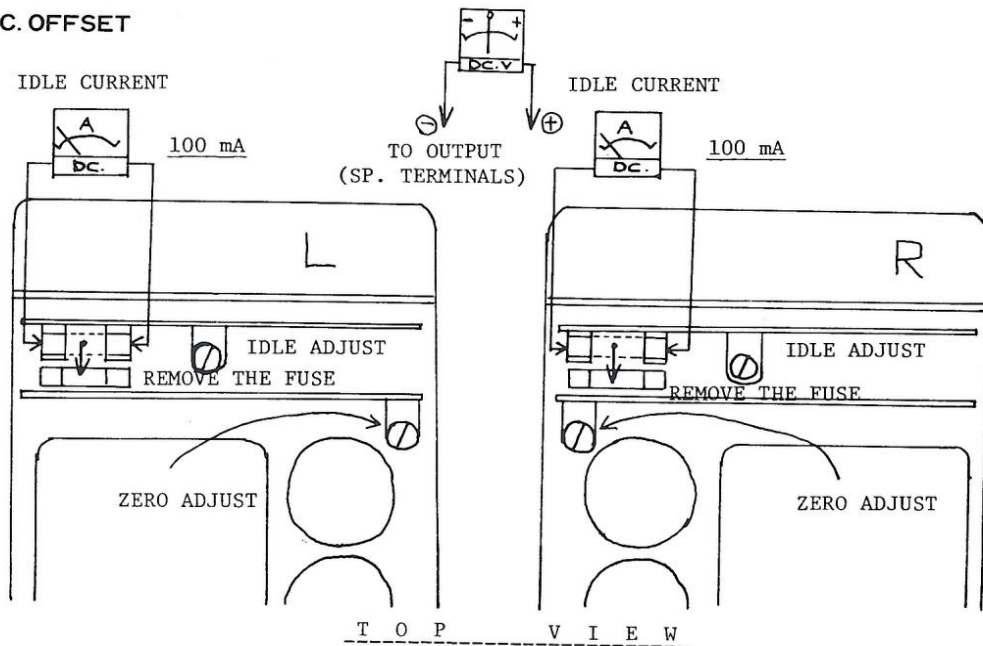

PB-1011

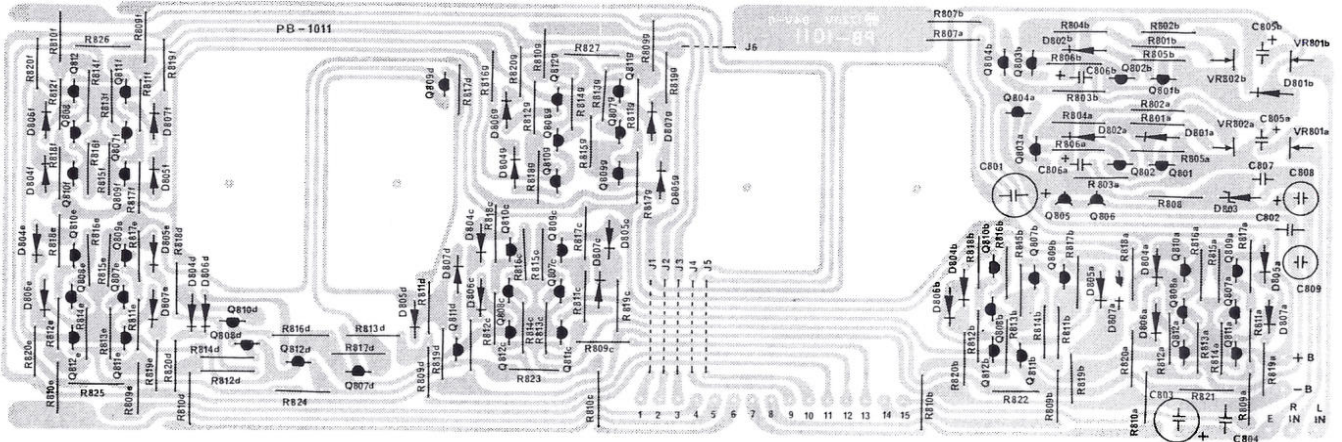

PB-1015

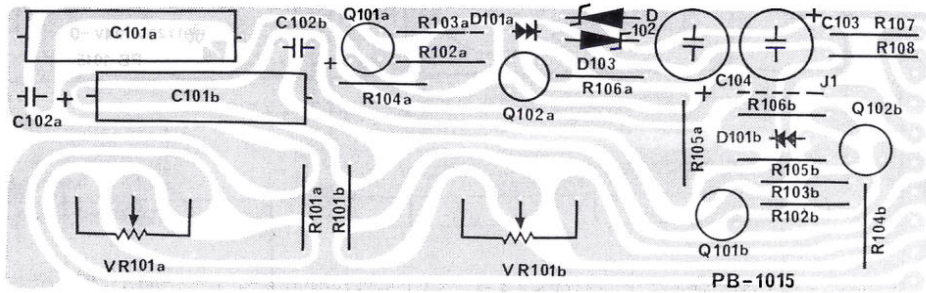

PB-1014

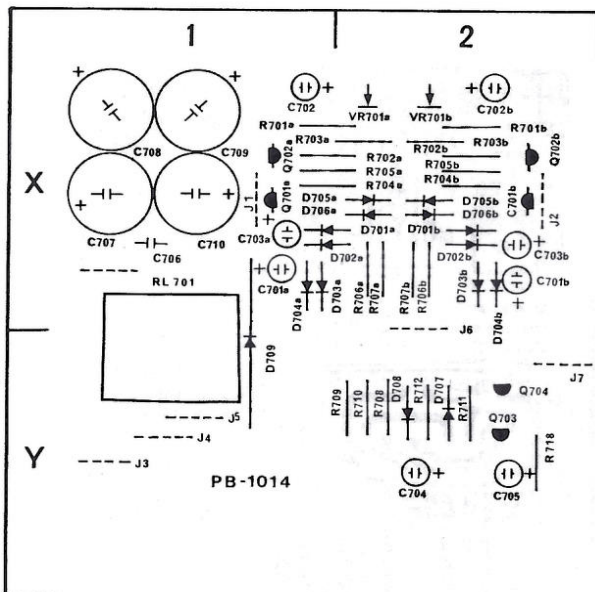

PB-1016

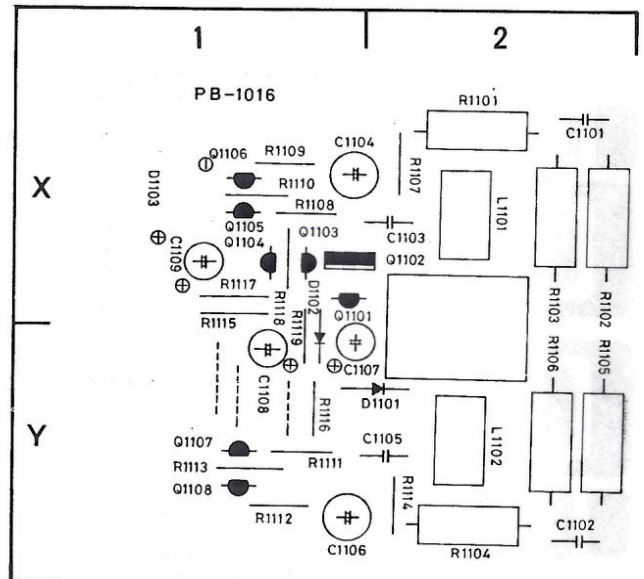



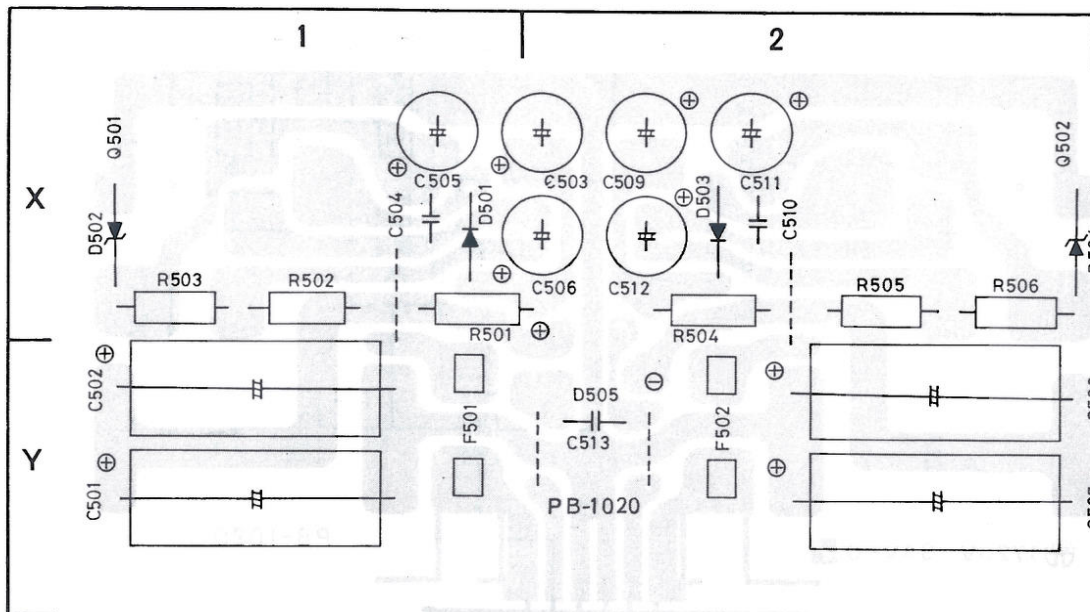
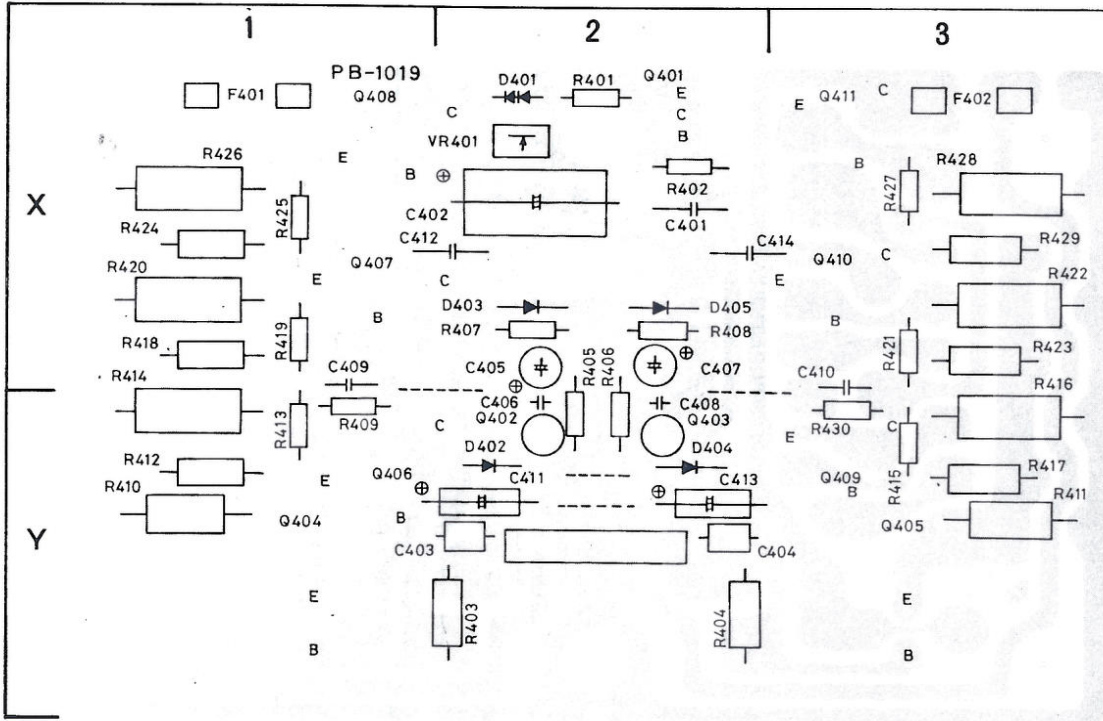
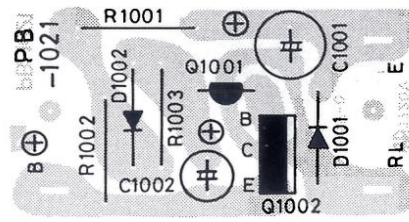
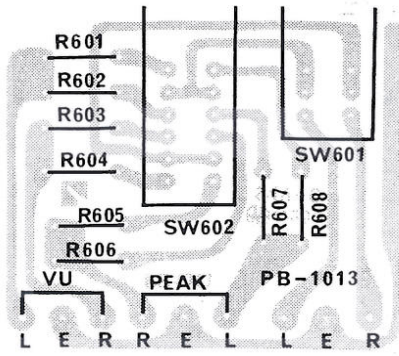

MODEL : M-4000  
**BLOCK DIAGRAM**

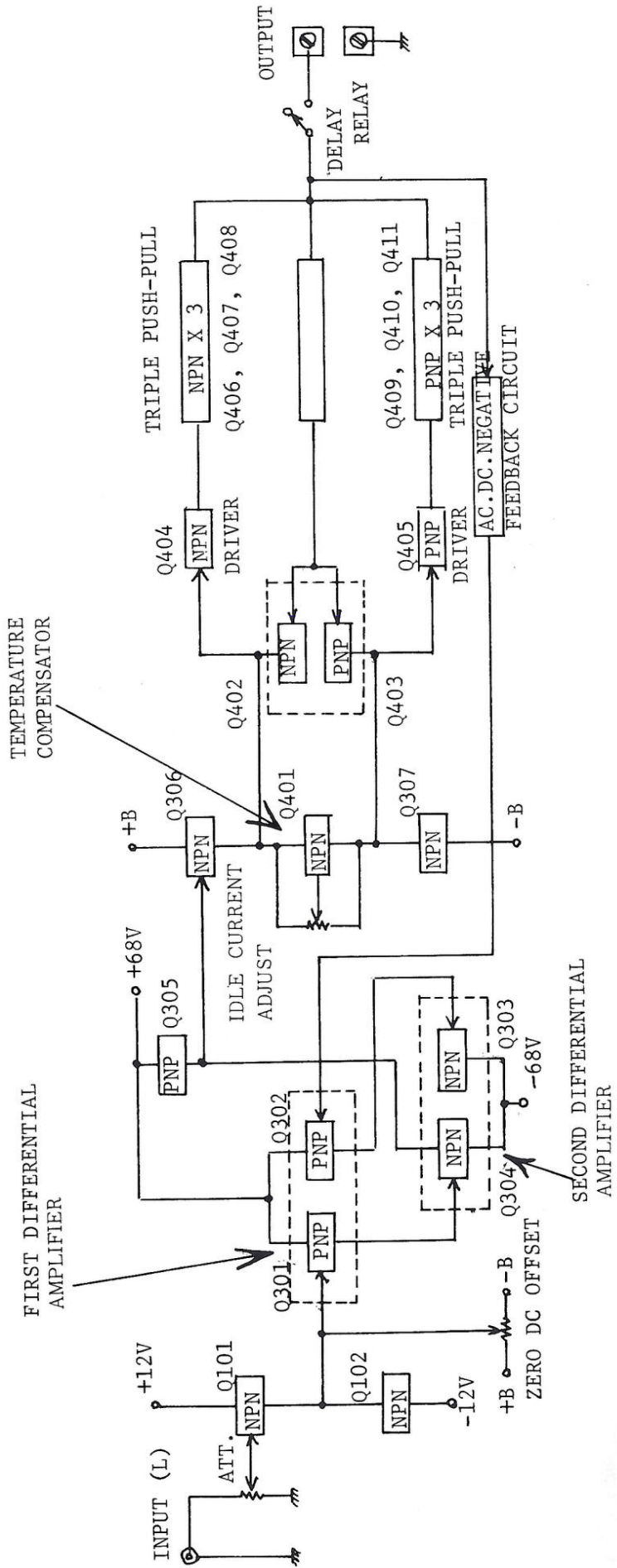



SYMBOL NO.

VR101a,b	50K	C101a,b	2.2uF 250V	D101a,b	VD1221
R102a,b	470K	102a,b	2.2uF 35V	102	BZ120
103a,b	820K	103	220uF 16V	103	BZ120
104a,b	150K	104	220V 16V		
105a,b	22K	Q101a,b	2SC1745		
106a,b	680	102a,b	2SC1745		
107	15K				
108	15K				

PB1014

VR701 a,b	100K-B	X2	C701 a	4.7uF 25V	X1	D702 a	WG713	X1
R701 a	22K	X1	701 b	4.7uF 25V	X2	702 b	WG713	X2
701 b	22K	X2	702 a	10uF 25V	X1	703 a	WG713	X1
702 a	10K	X1	702 b	10uF 25V	X2	703b	WG713	X2
702 b	10K	X2	703 a	4.7uF 25V	X1	704a	WG713	X1
703 a,b	100	X2	704	10uF 25V	Y2	704 b	WG713	X2
704 a	33K	X1	705	10uF 25V	Y2	705a,b	WG713	X2
704 b	33K	X2	706	0.1uF	X1	706a,b	WG713	X2
705 a	18K	X1	707	330uF 35V	X1	707	WG713	Y2
705 b	18K	X2	708	330uF 35V	X1	708	WG713	Y2
706 a,b	56K	X2	709	330uF 35V	X1	709	HiFi special	Y1
707 a,b			710	330uF 35V	X1			
708	1.2K	2Y	Q701 a	2SC734	X1			
709	33K	2Y	701 b	2SC734	X2			
710	47K	2Y	702 a	2SC734	X1			
711	1.2M	2Y	702 b	2SC734	X2			
712	1.2M	2Y	703	2SC734	Y2			
713	1.2K	2Y	704	2SC734	Y2			

PB1013

SYMBOL NO.

R601	350K	R605	76K
602	105K	606	304K
603	350K	607	76K
604	105K	608	304K

PB1011

SYMBOL NO.

VR801 a,b	50K-B	R821	562	Q806	2SC734
VR802 a,b	180K	822	392	807 a-g	2SA561
R801 a,b	180K	823	280	808 a-g	2SA561
802 a,b	4.7K	824	196	809 a-g	2SC734
803 a,b	22K	825	140	810 a-g	2SC734
804 a,b	82K	826	97.6	811 a-g	2SC734
805 a,b	10K	827	239	812 a-g	2SC734
806 a,b	18K	C801	100uF 35V	D801 a,b	WG713
807 a,b	6.8K	802	0.1uF	802 a,b	WG713
808	2.7K	803	100uF 35V	803	BZ192
809 a-g	820	804	0.1uF	805 a-g	WG713
810 a-g	820	805a,b	4.7uF 25V	806 a-g	WG713
811 a-g	1.2M	806 "	1uF 25V	807 a-g	WG713
812 a-g	1.2M	807 "	0.022uF	808 a-g	WG713
813 a-g	1K	808 "	10uF 25V		
814 a-g	1K	809 "	10uF 25V		
815 a-g	4.7K	Q801 a,b	2SC734		
816 a-g	4.7K	802 a,b	2SC734		
817 a-g	56K	803 a,b	2SC734		
818 a-g	56K	804 a,b	2SA561		
819 a-g	22K	805 a,b	2SC734		
820 a-g	22K				

MODEL: M-4000 Replacement Parts List

PB1019

SYMBOL NO.

VR401	1K		2X	R423	10	1W	3Y	Q401	2SC1904	2X
R401	1.2K	1/2W	2X	424	10	1W	1X	402	2SC1745	2Y
402	1.8K	"	2X	425	10	1/2W	1X	403	2SA855	2Y
403	220	1W	2Z	426	0.18	5W	1X	404	2SC783	1Z
404	220	"	2Z	427	10	1/2W	3X	405	2SA483	3Z
405	100	1/2W	2Y	428	0.18	5W	2X	406	2SD424	1Z
406	100	1/2W	2Y	429	10	1W	3X	407	2SD424	1X
407	6.8K	1/2W	2Y					408	2SD424	1X
408	6.8K	1/2W	2Y	C401	0.22uF	250V	2X	409	2SB554	3Y
409	47	1/2W	1Y	402	330uF	25V	2X	410	2SB554	3X
410	100	2W	1Z	403	3900pF		2Z	411	2SB554	3X
411	100	2W	3Z	404	3900pF		2Z			
412	10	1W	1Y	405	33uF	16V	2Y	D401	SV02	2X
413	10	1/2W	1Y	406	4.7pF	50V	2Y	402	1N4448	2Y
414	0.18	5W	1Y	407	33uF	16V	2Y	403	1N4448	2Y
415	10	1/2W	3Y	408	4.7pF	50V	2Y	404	1N4448	2Y
416	0.18	5W	3Y	409	0.022uF	250V	3Y	405	1N4448	2Y
417	10	1W	3Y	410	0.022uF	250V	3Y			
418	10	1W	1Y	411	1uF	50V	2Z	F401	6.3A	1X
419	10	1/2W	1Y	412	0.1uF	250V	2X	402	6.3A	3X
420	0.18	5W	1Y	413	1uF	50V	2Z			
421	10	1/2W	3Y	414	0.1uF	250V	2X			
422	0.18	5W	3Y							

PB1020

SYMBOL NO.

R501	100	1W	1X	C505	33uF	100V	1X	Q501	2SC783	1X
502	4.7K	1W	1X	506	470uF	16V	1X	502	2SA483	2X
503	1K	1W	1X	507	220uF	100V	2Y	D501	1N4003	1X
504	100	1W	2X	508	220uF	100V	2X	502	1N4760A	1X
505	4.7K	1W	2X	509	33uF	100V	2X	503	1N4003	2X
506	1K	1W	2X	510	0.1uF	50V	2X	504	1N4760A	2X
C501	220uF	100V	1Y	511	33uF	100V	2X	505	2RB40	2Y
502	220uF	100V	1Y	512	470uF	16V	2X			
503	33uF	100V	1Y	513	0.01uF	150V	2Y	F501	0.5A	1Y
504	0.1uF	50V	1X					502	0.5A	2Y

PB1021

SYMBOL NO.

R1001	8.2K	Q1001	2SC234
1002	1.5K	1002	2SC734
1003	100K		
C1001	10uF	D1001	1N4002
1002	33uF	1002	1N4448

PB1016

SYMBOL NO.

R1101	1K	5W	2X	R1115	8.2K	1Y	Q1101	2SC734	1Y	
1102	10	5W	2X	1116	1.5K	1Y	1102	2SD234	1X	
1103	4700	5W	2X	1117	8.2K	1Y	1103	2SC734	1X	
1104	1K	5W	2Y	1118	1K	1X	1104	2SA561	1X	
1105	10	5W	2Y				1105	2SC734	1X	
1106	4.7	5W	2Y	C1101	1uF	250V	2X	1106	2SC734	1X
1107	18K		2X	1102	1uF	250V	2Y	1107	2SC734	1Y
1108	2.7K		1X	1103	0.1uF	250V	2X	1108	2SC734	1Y
1109	10K		1X	1104	100uF	25V	2Y			
1110	3.9K		1X	1105	0.01uF	250V	2Y	D1101	1N4448	2Y
1111	2.7K		1Y	1106	100uF	25V	1Y	1102	1N4448	1Y
1112	10K		1Y	1107	10uF	50V	1Y	1103	2SRB10	1X
1113	3.9K		1Y	1108	100uF	25V	1Y			
1114	18K		2Y	1109	4.7uF	50V		L1101		2X
								1102		2Y

## SYMBOL NO.

VR301	5K-B	R320	33K 1W	Q301	2SA810
R301	3.3K 1/2W	C301	4.7uF 25V	302	2SA810
302	220 1/2W	302	4.7uF 250V	303	2SC805
303	220 1/2W	303	330pF 50V	304	2SC805
304	22K 1/2W	304	1000pF 100V	305	2SA762
305	22K 1/2W	305	220pF	306	2SC1431
306	15	306	220uF 16V	307	2SC1431
307	15	307	0.22uF 250V	D301	1N4448
308	56K 1/2W	308	1000pF 100V	302	1N4448
309	680 1/2W	309	47pF 100V	303	SV02
310	5.6K	310	47pF 100V	304	SV02
311	5.6K	311	0.1uF 250V	F301	0.5A
312	1.2K 1/2W	312	33uF 100V	302	0.5A
313	390 1W	313	0.1uF 250V		
314	47 1/2W	314	33uF 100V		
315	100 1W	315	100pF 100V		
316	33K 1W	316	0.22uF 250V		
317	47 1/2W	317	0.1uF 250V		
318	47 1/2W	318	0.1uF 250V		
319	100 1W	319	150pF 100V		

SPECIFICATIONS

Power Output:	180 watts minimum continuous per channel into 8-ohm loads both channels driven at any frequency from 20Hz to 20,000Hz with no more than 0.05% total harmonic distortion.
Rated I.M.:	no more than 0.05% (180W/ch, 60Hz : 7KHz = 4 : 1)
Frequency Response:	3 - 100,000Hz ( $\pm$ 1dB)
Input Sensitivity:	1V (8-ohm, 180W/ch, 1KHz)
Input Impedance:	50K ohms
Residual Hum & Noise:	-108dB
Crosstalk:	better than 90dB (vol. max 1KHz) better than 70dB (vol. max 20KHz)
Dimensions:	485(W) x 390(D) x 175(H)mm (19-1/8" x 15-3/8" x 6-7/8")
Weight:	Net 28Kgs (62 lbs.) Gross 31Kgs (68 lbs.)

Specifications and appearance design subject to possible change without notice.



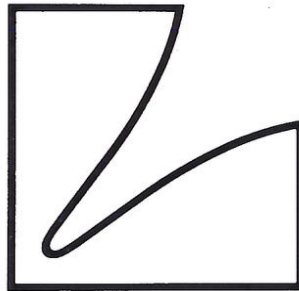

**LUX CORPORATION, JAPAN**

**HEAD OFFICE & FACTORY**  
1-8-31 NAGAHASHI, NISHINARI-KU OSAKA  
PHONE:632 0031 CABLE:LUXELECT OSAKA  
TELEX:J63694

**LUX AUDIO OF AMERICA LTD.**

200 Aerial Way, Syosset, New York 11791. U.S.A.  
PHONE: (516) 822-7070









