

**SOLID STATE INTEGRATED AMPLIFIER**

**L-85V**

**SERVICE MANUAL**



L-85V P.B. LOCATION & ADJUSTMENT

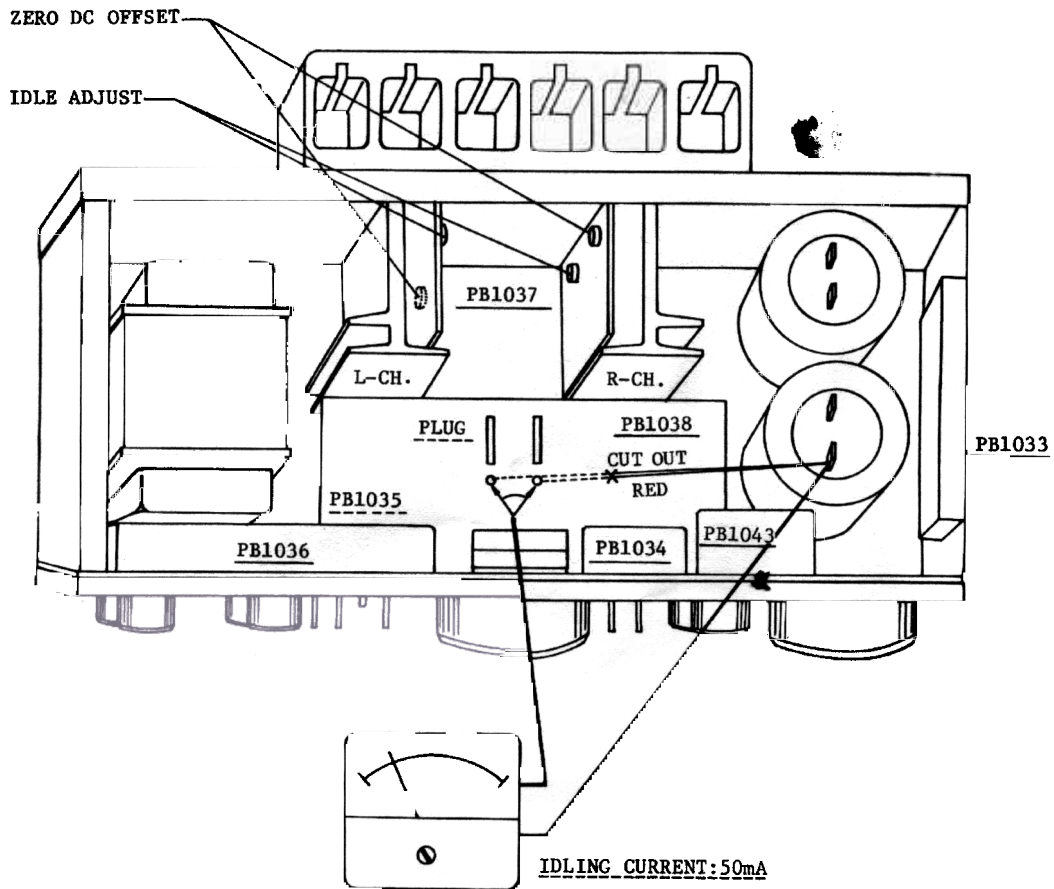

PB-1033

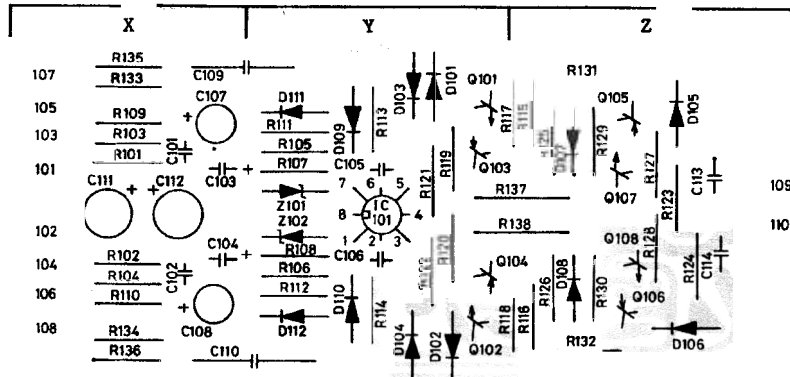

PB-1033 6731V 94V.

PB-1034

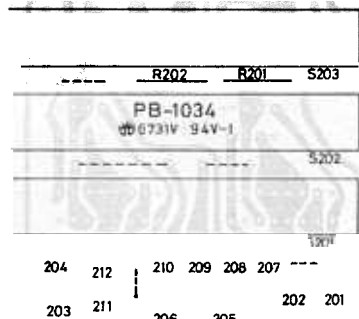

PB-1035

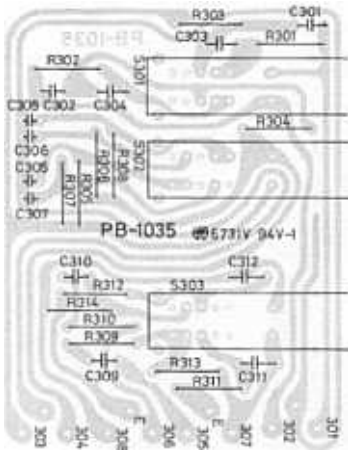

PB-1037

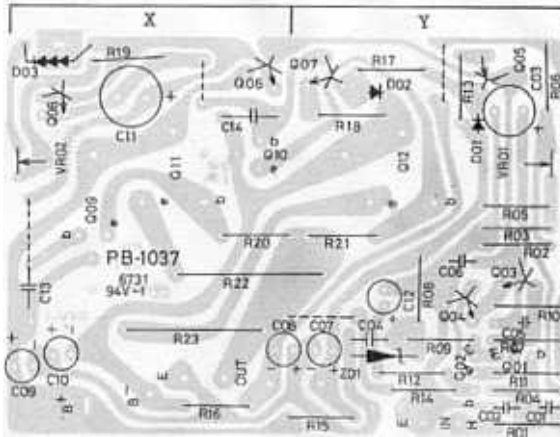

PB-1036

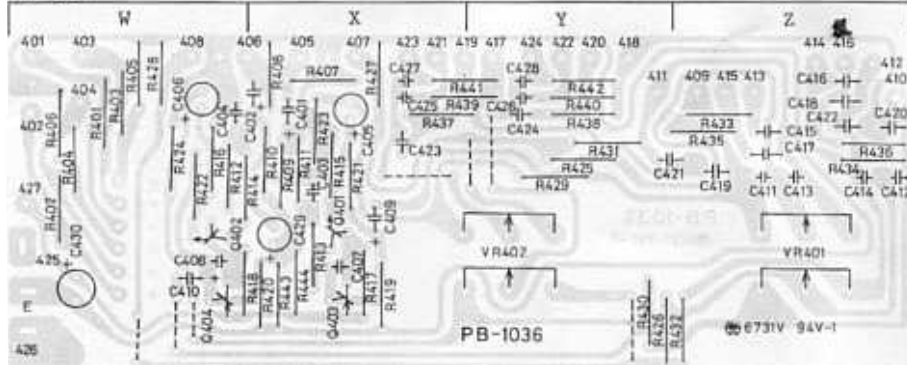

PB-1038

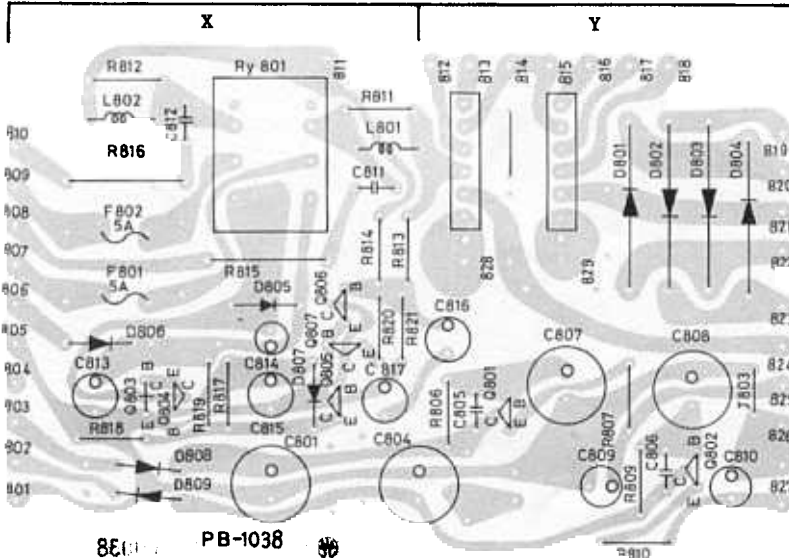

PB-1043

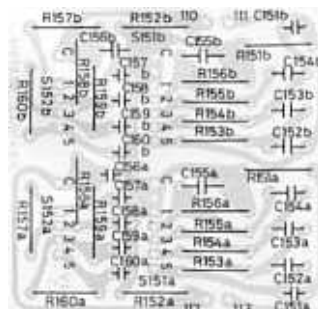

Replacement Parts List

PB1033

R101	56K	X	R118	470	Z	C109	1uF	X
102	56K	X	119	12K	Y	110	1uF	X
103	3.3K	X	120	12K	Y	111	100uF 25V	X
104	3.3K	X	121	12K	Y	112	100uF 25V	X
105	180	Y	122	12K	Y	113	0.1uF	Z
106	180	Y	123	12K	Y	114	0.1uF	Z
107	330K	Y	124	3.3K	Z	D101	WG713	Y
108	330K	Y	125	3.3K	Z	102	WG713	Y
109	680	X	126	3.3K	Z	103	WG713	Y
110	680	X	127	3.3K	Z	104	WG713	Y
111	1K	Y	128	82	Z	105	WG713	Y
112	1K	Y	129	82	Z	106	WG713	Z
113	1.5K	Y	130	82	Z	107	WG713	Z
114	1.5K	Y	131	39K	Z	108	WG713	Z
115	470	Y	132	39K	Z	109	---	Y
116	470	Y	133	270	X	110	---	Y
117	470	Y	134	270	X	111	---	Y
			135	100K	X	112	---	Y
			136	100K	X	Z101	WZ120	Y
			137	2.2K 1W	Z	102	WZ120	Y
			138	2.2K 1W	Z	Q101	28C1345	Y
			C101	47pF	X	102	28C1345	Y
			102	47pF	X	103	28A640	Y
			103	10uF 16V	X	104	28A640	Y
			104	10uF 16V	X	105	28S548	Z
			105	47pF	Y	106	28S548	Z
			106	47pF	Y	107	28D414	Z
			107	22uF 10V	X	108	28D414	Z
			108	22uF 10V	X	IC101	NJM4558	Y

PB1035

R301	1M	C301	0.039uF
302	1M	302	0.039uF
303	4.7K	303	0.1uF
304	4.7K	304	0.1uF
305	1M	305	3300pF
306	1M	306	3300pF
307	1M	307	1800pF
308	1M	308	1800pF
309	470K	309	100pF
310	470K	310	100pF
311	22K	311	0.033uF
312	22K	312	0.033uF
313	---	313	---
314	---	314	0.033uF

PB1036

VR401 a,b	50K-B	W	R418	15K	X	R435	1M	Z
VR402 a,b	50K-B	Y	419	15K	X	436	1M	Z
R403	1M	W	420	15K	X	437	1M	X
404	1M	W	421	220K	X	438	1M	X
405	27K	W	422	220K	W	439	1M	Y
406	27K	W	423	220K	W	440	1M	X
407	470K	X	424	3.9K	W	441	1M	X
408	470K	X	425	220K	Y	442	1M	Y
409	470K	X	426	220K	Y	443	27K	X
410	470K	X	427	220K	X	444	5.6K	X
411	2.7K	X	428	3.9K	W	CA01	2.2uF 10V	X
412	2.7K	X	429	10K	Y	402	2.2uF 10V	X
413	180	X	430	10K	Y	403	47pF	X
414	180	X	431	10K	Y	404	47pF	X
415	47K	X	432	10K	Z	405	33uF 10V	W
416	47K	W	433	10K	Z	406	33uF 10V	X
417	15K	X	434	1M	Z			

PB1043

R151 a,b	510K	R158 a,b	1.5M	C155 a,b	0.082uF
152 a,b	39K	159 a,b	1.5M	156 a,b	1500pF
153 a,b	1M	160 a,b	1.5M	157 a,b	1200pF
154 a,b	1M	C151 a,b	8200pF	158 a,b	820pF
155 a,b	1M	152 a,b	0.082uF	159 a,b	560pF
156 a,b	1M	153 a,b	0.082uF	160 a,b	270pF
157 a,b	1.5M	154 a,b	0.082uF		

PB1036

22pF	X	C417	0.068uF	Z	C427	0.039uF	X
22pF	W	418	0.068uF	Z	428	0.039uF	Y
2.2uF 10V	X	419	0.027uF	Z	429	47uF 25V	X
2.2uF 10V	W	420	0.027uF	Z	430	47uF 25V	W
1000pF	Z	421	0.039uF	Z	Q401	2SC1345	X
1000pF	Z	422	0.039uF	Z	402	2SC1345	W
1000pF	Z	423	0.018uF	X	403	2SA640	X
1000pF	Z	424	0.018uF	Y	404	2SA640	W
0.039uF	Z	425	8200pF	X			
0.039uF	Z	426	8200pF	Y			

4.7K	Y	R18	150	Y	C13	100pF	X
1K	X	19	2.4K	X	14	100pF	X
4.7K	Y	20	82	1/2W X	D01	VD122K	Y
220	Y	21	82	1/2W Y	02	VD122K	Y
220	Y	22	0.33	5W X	03	5.6K	X
100K	Y	23	0.33	5W X	Z01	WZ120	Y
33K 1/2W	Y	C01	10uF 16V	Y	Q01	2SA620	Y
33K 1/2W	Y	02	220pF	Y	02	2SA620	Y
3.3K	Y	03	47uF 10V	Y	03	2SC1940	Y
8.2K 1/2W	Y	04	0.04uF	Y	04	2SC1940	Y
8.2K	Y	05	33pF	Y	05	2SC815	Y
180 1/4W	Y	06	100pF	Y	06	2SC1940	X
3.3K	Y	07	-----	Y	07	2SC1940	Y
680	Y	08	47uF 63V	X	08	2SC734	X
5.6K	Y	09	2.2uF 100V	X	09	2SD382	X
100K	Y	10	2.2uF 100V	X	10	2SB537	X
100	Y	11	47uF 6.3V	X	11	2SC1079	X
4.7K	X	12	33uF 10V	-	12	2SA679	Y
47K 1/2W	Y						

PB1038

	Y	C812	0.1uF	X	Q805	2SC945	X
10K	Y	813	22uF 50V	X	806	2SC945	X
270 1/4W	Y	814	100uF 10V	X	807	-----	X
10K	Y	815	10uF 35V	X			
270 1/4W	Y	816	330uF 10V	Y			
22 1/2W	X	817	330uF 10V	X			
22 1/4W	X	L801	LUX1004	X			
8.2K	X	802	LUX1004	X			
8.2K	X	F801	5A	X			
4.7K 2W	X	802	5A	X			
4.7K 2W	X						
180K	X	D801	HiFi special	Y			
1.5K	X	802	HiFi special	Y			
8.2K	X	803	HiFi special	Y			
1K	X	804	HiFi special	Y			
3.3K	X	805	WG713	X			
100uF 63V	X	806	1N4003	X			
100uF 63V	X	807	1K188	X			
150pF	Y	808	1N4003	X			
150pF	Y	809	1N4003	X			
100uF 50V	Y	Q801	2SC734	Y			
100uF 50V	Y	802	2SA561	Y			
47uF 50V	Y	803	2SC735	X			
47uF 50V	Y	804	2SC945	X			
0.1uF	X						

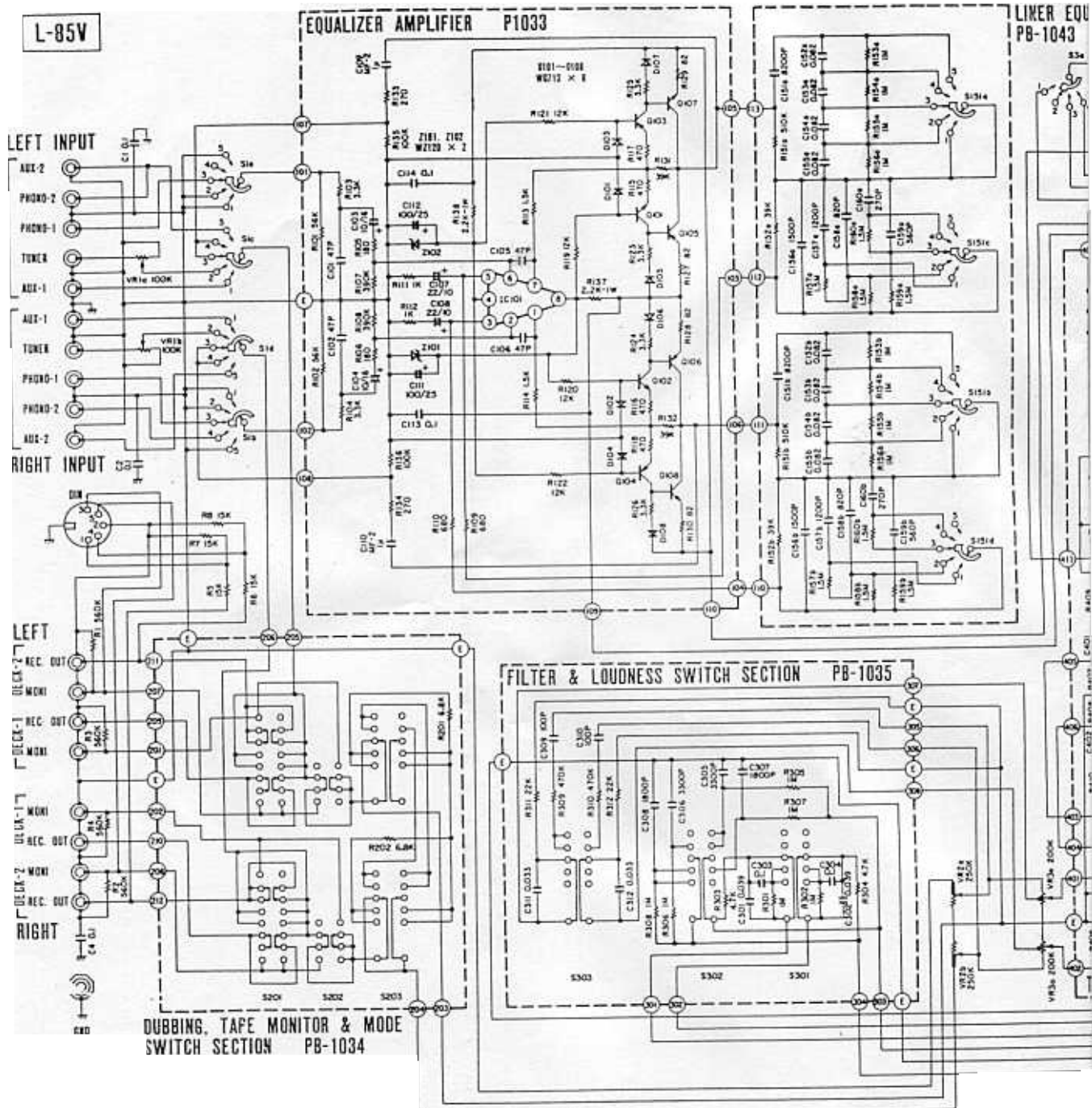

Q101.102. Q401.402	.....2SC1345	Q509	Q609	...2SD382
Q103.104. Q403.404	.....2SA640	Q510	Q610	...2SB537
Q105.106	.....2SB548	Q511	Q611	...2SC1079
Q107.108	.....2SD414	Q512	Q612	...2SA679
Q501.502. Q601.602	.....2SA620	Q801	.....	...2SC734
Q503.504. Q603.604	.....2SC1940	Q802	.....	...2SA561
Q505	Q605	.....2SA915	Q803	.....2SC735
Q506.507. Q606.607	.....2SC1940	Q804.805.806	.....	...2SC945
Q508	Q608	.....2SC734	IC101	.....NJM4558

- S1a,b,c,d .....INPUT SELECTOR (1. AUX-1, 2. TUNER, ③ PHONO-1, 4. PHONO-2)
- S2a,b.....BASS (1. 150Hz, 2. 300Hz ③ DEFEAT, 4. FLAT)
- S3a,b.....TREBLE (1. 1.5KHz, ② DEFEAT, 3. 3KHz, 4. 6KHz)
- S4a,b,c,d .....SPEAKERS (1. OFF, ② A, 3. B, 4. A+B)
- S5a,b.....POWER (1. OFF, ② IN)
- S151a,b,c,d.....LINER EQUALIZER (1. 2. UP TILT, ③ FLAT, 4. 5. DOWN TILT)
- S201.....DUBBING (1. 1 TO 2, ② SOURCE, 3. 2 TO 1)
- S202.....MONITOR (1. DECK-1, ② SOURCE, 3. DECK-2)
- S203.....MODE (1. REVERS, ② STEREO, 3. MONO)



EQ EQUALIZER SWITCH SELECTION  
-1043

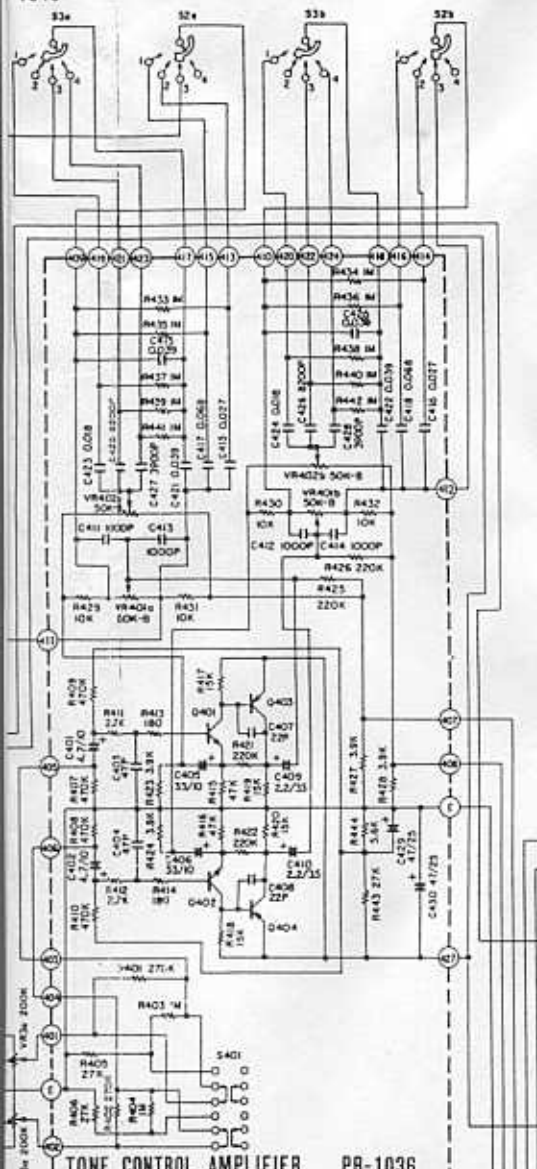

L ch MAIN AMPLIFIER PB-1037

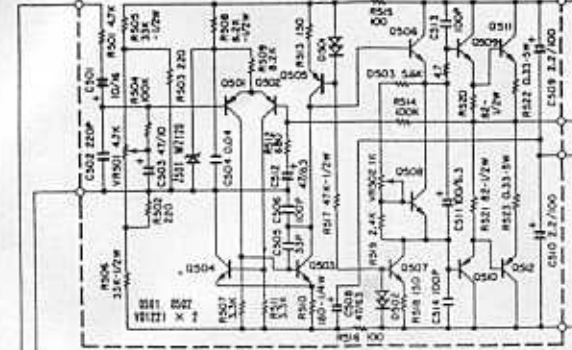

R ch MAIN AMPLIFIER PB-1037

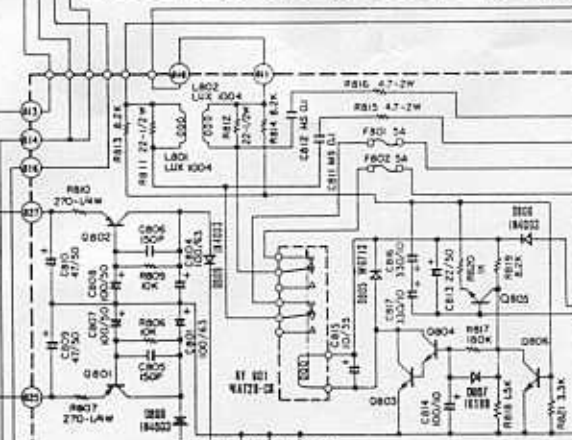
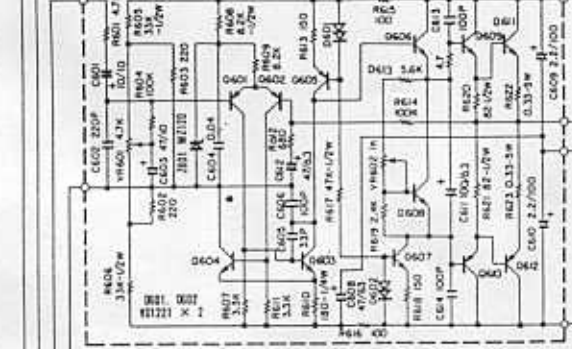

POWER SUPPLY, RIPLE FILTER & MUTING PROTECTOR PB-1038

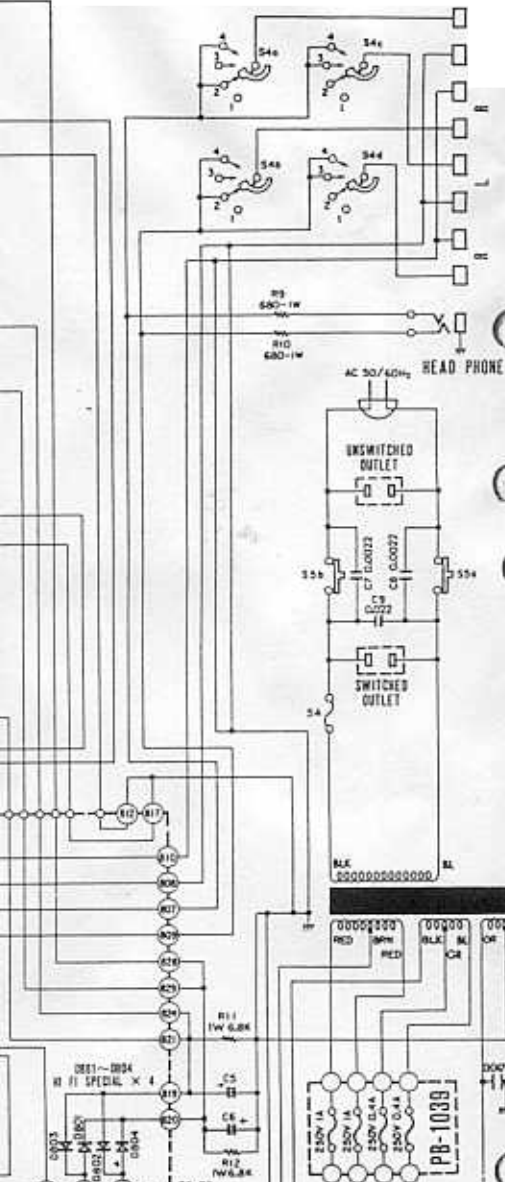
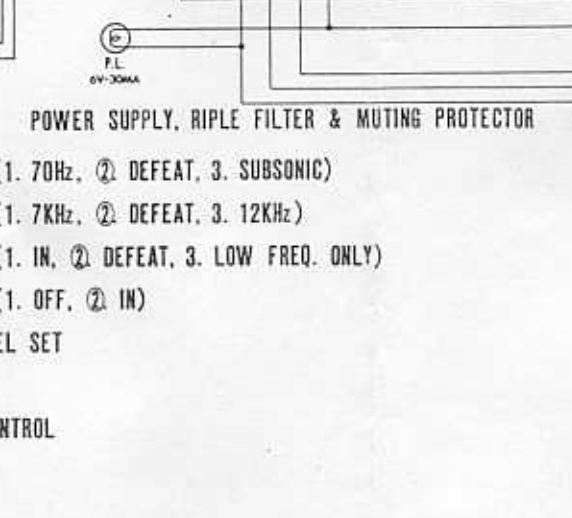

- PHONO-1, 4. PHONO-2, 5. AUX-2)
- ATTEN (1. OFF, 2. IN)
- BASS (1. 20Hz, 2. 40Hz, 3. 60Hz, 4. 80Hz)
- TREBLE (1. 10KHz, 2. 12KHz)
- BALANCE (1. LEFT, 2. CENTER, 3. RIGHT)
- VOLUME (1. 10dB, 2. 20dB, 3. 30dB, 4. 40dB, 5. 50dB)
- DEFLECT (1. 10, 2. 20, 3. 30, 4. 40, 5. 50)
- MONO

- S301 .....LOW CUT (1. 70Hz, ② DEFEAT, 3. SUBSONIC)
- S302 .....HIGH CUT (1. 7KHz, ② DEFEAT, 3. 12KHz)
- S303 .....LOUDNESS (1. IN, ② DEFEAT, 3. LOW FREQ. ONLY)
- S401 .....ATTENUATE(1. OFF, ② IN)
- VR1a,b .....TUNER LEVEL SET
- VR2a,b .....BALANCE
- VR3a,b .....VOLUME CONTROL
- VR401a,b .....BASS
- VR402a,b .....TREBLE

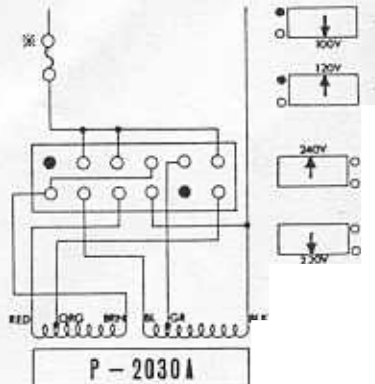

"DUE TO CONTINUED IMPROVEMENTS LUX RESERVE THE RIGHT TO ALTER THE CIRCUIT OR SPECIFICATIONS"

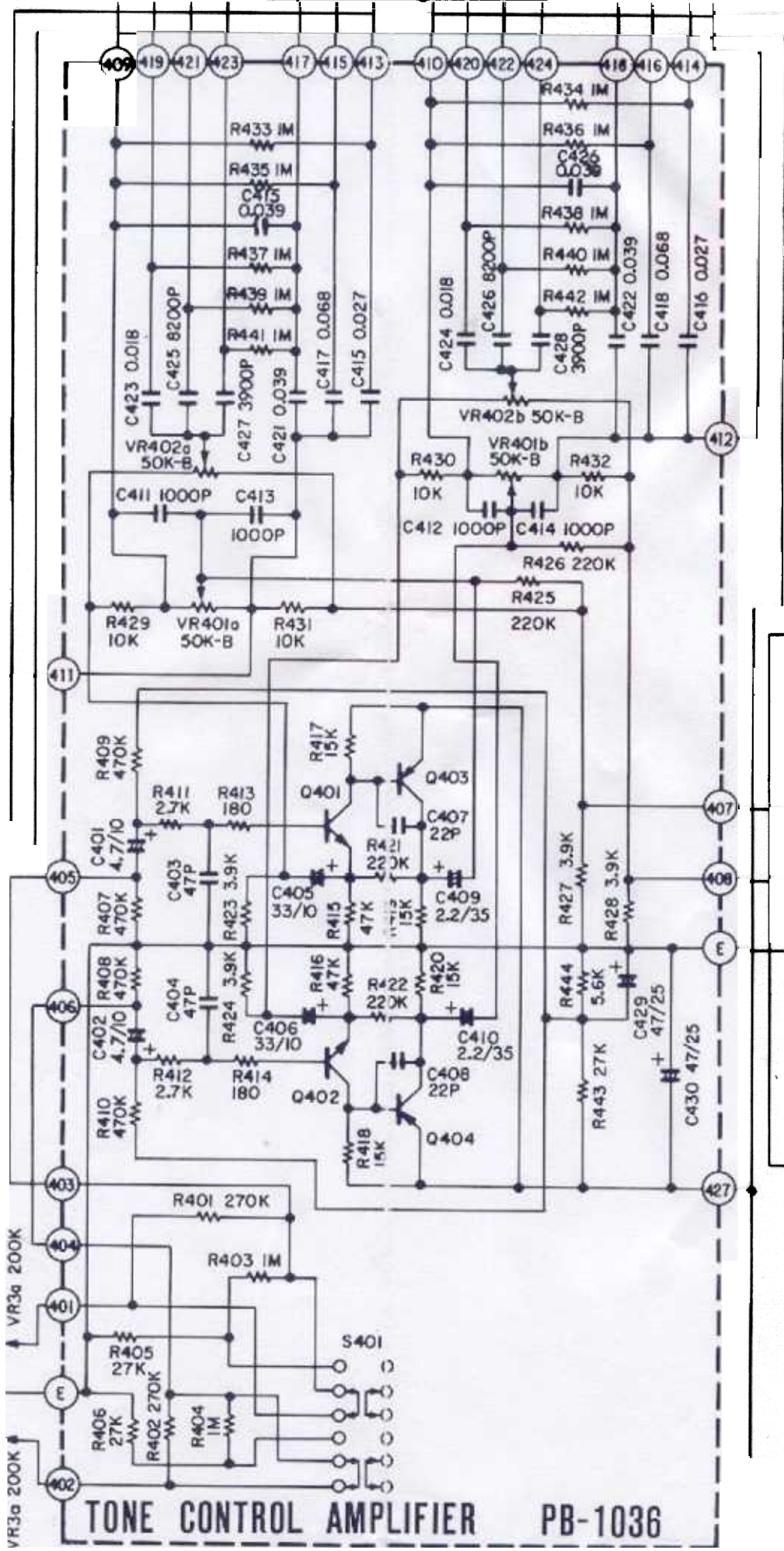



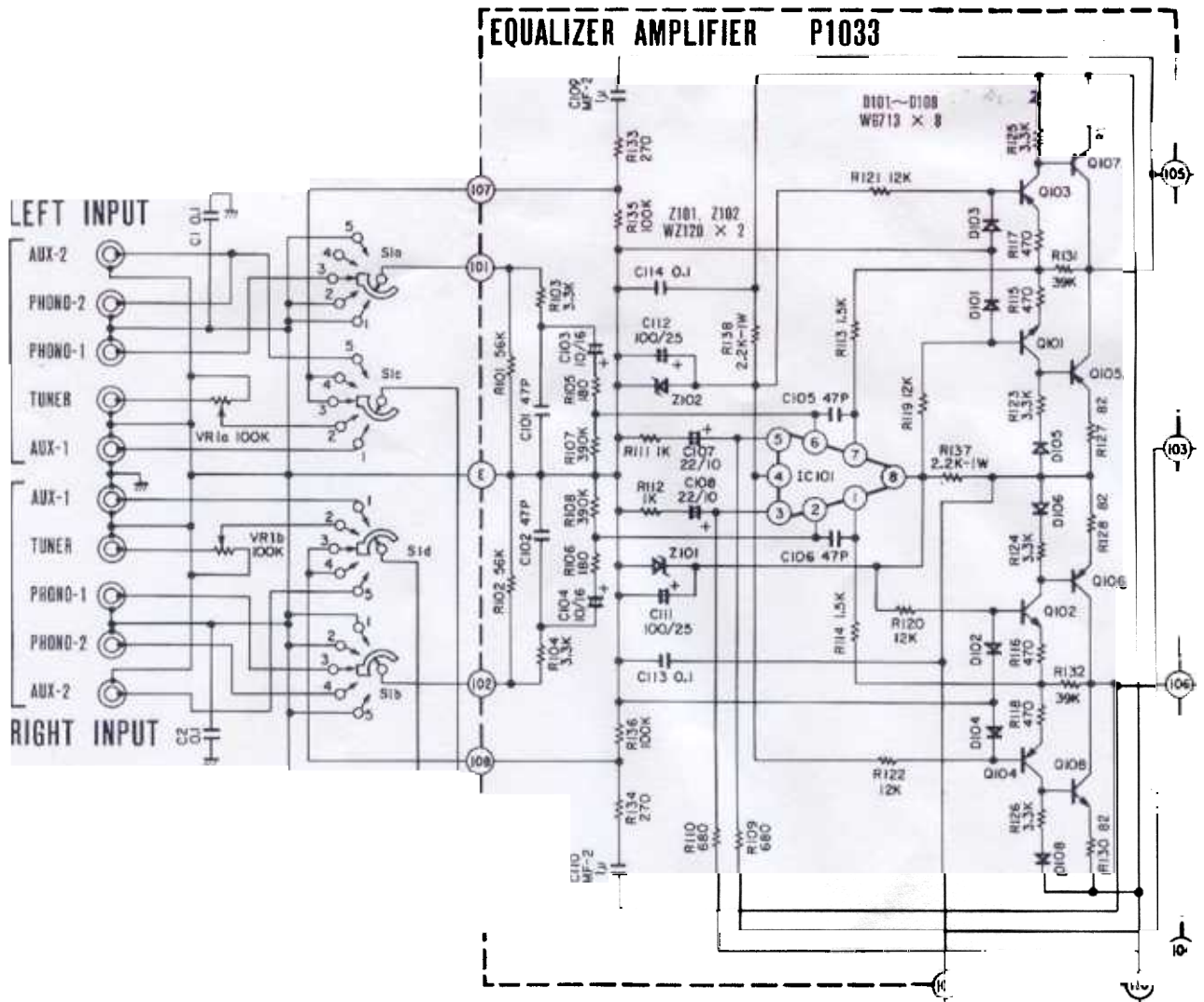

### L ch MAIN AMPLIFIER PB-1037

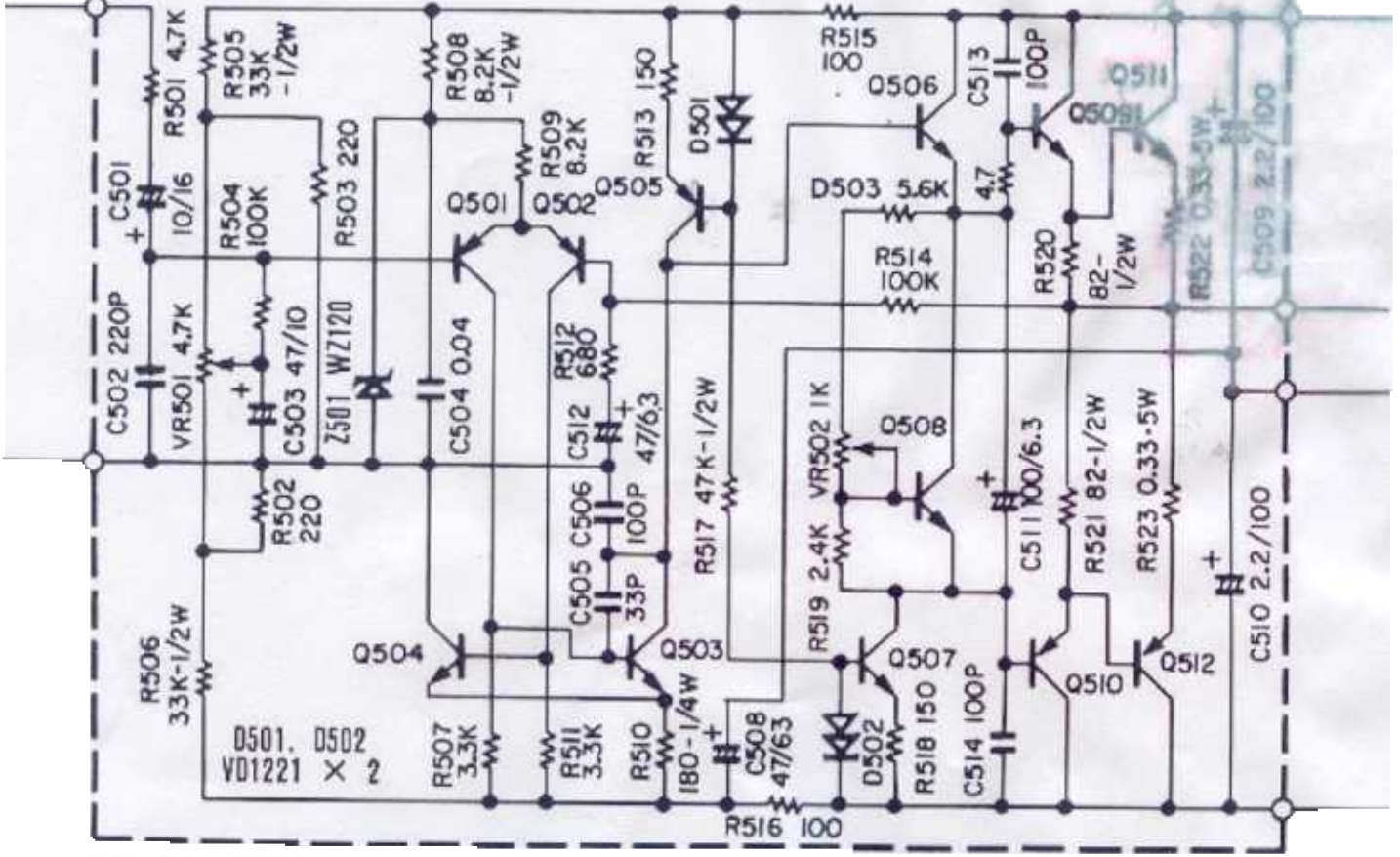

### R ch MAIN AMPLIFIER PB-1037

