

# SERVICE MANUAL

## PARTS LIST

GXC-735D

**MODEL GXC-735D**

**AKAI**

ALSO APPLICABLE TO BLACK PANEL MODEL



## STEREO QUICK REVERSE CASSETTE DECK

# MODEL GXC-735D

ALSO APPLICABLE TO BLACK PANEL MODEL

SECTION 1	SERVICE MANUAL .....	3
SECTION 2	PARTS LIST .....	41
SECTION 3	SCHEMATIC DIAGRAM .....	62



---

SECTION 1

**SERVICE MANUAL**

TABLE OF CONTENTS

I. TECHNICAL DATA .....	4
II. DISMANTLING OF UNIT .....	5
III. CONTROLS .....	6
IV. PRINCIPAL PARTS LOCATION .....	7
V. CIRCUIT OPERATING PRINCIPALES .....	8
1. AUTO-STOP & REVERSE OPERATIONS .....	20
2. OPERATION OF AUXILIARY CIRCUITS ON THE POWER SUPPLY P.C BOARD .....	22
VI. REEL TABLE DRIVE MECHANISM .....	23
VII. MECHANISM ADJUSTMENT .....	24
VIII. HEAD ADJUSTMENT .....	28
IX. AMPLIFIER ADJUSTMENT .....	30
X. DC RESISTANCE OF VARIOUS COILS .....	33
XI. CLASSIFICATION OF VARIOUS P.C BOARDS .....	33

For basic adjustments, measuring methods, and operating principles, refer to GENERAL TECHNICAL MANUAL.

## I. TECHNICAL DATA

TRACK SYSTEM	4 track, 2 channel stereo system
TAPE	Philips type cassette
TAPE SPEED	4.76 cm/s $\pm 1.0\%$ (1-7/8 ips $\pm 1.0\%$ )
WOW AND FLUTTER	Less than 0.045% WRMS, 0.12% (DIN 45500, 45507)
FREQUENCY RESPONSE	35 to 14,000 Hz $\pm 3$ dB using LN tape 35 to 14,000 Hz $\pm 3$ dB using LH tape 35 to 15,000 Hz $\pm 3$ dB using CrO <sub>2</sub> (SA) tape 35 to 16,000 Hz $\pm 3$ dB using FeCr tape
DISTORTION (1,000 Hz 0 VU)	Less than 1.0% using LN tape Less than 1.0% using LH tape Less than 1.5% using CrO <sub>2</sub> (SA) tape Less than 1.5% using FeCr tape
SIGNAL TO NOISE RATIO	Better than 55 dB using LN tape Better than 55 dB using LH tape Better than 56 dB using CrO <sub>2</sub> (SA) tape Better than 56 dB using FeCr tape (measured via tape with peak recording level) Dolby NR switch ON: Improves up to 10 dB above 5 kHz
ERASE RATIO	Better than 65 dB
BIAS FREQUENCY	85 kHz
HEADS	(3): One GX recording/playback head, Two erase heads (2): One Electronically speed controlled D.C. motor for Capstan drive One DC Motor for Reel Drive
FAST FORWARD AND REWIND TIME	60 sec. using a C-60 cassette tape
OUTPUT JACKS	Line (2): 410 mV (0 VU). Required load impedance; More than 20 kohms Phone (1): 100 mV/8 ohms
INPUT JACKS	Microphone (2): 0.25 mV (Input impedance 5.0 kohms) Required microphone impedance; 600 ohms Line (2): 70 mV (Input impedance 100 kohms)
DIN JACK	Input: 0.25 mV (Input impedance 2.2 kohms) Output: 410 mV. Required load impedance; More than 20 kohms
POWER REQUIREMENTS	100V, 50/60 Hz for Japan 120V/60 Hz for U.S.A. and Canada 110-120/220-240V (Switchable), 50/60 Hz for the other countries
DIMENSIONS	440(W) x 150(H) x 290(D) mm, (17.3 x 5.9 x 11.4")
WEIGHT	9.7 kg (21.4 lbs)

\* For improvement purposes, specifications and design are subject to change without notice.

\* "Dolby" and the Double D symbol are trademarks of Dolby Laboratories (Manufactured under license from Dolby Laboratories).

## II. DISMANTLING OF UNIT

In case of trouble, etc. necessitating dismantling, please dismantle in the order shown in the photographs. Reassemble in reverse order.

1



SCREWS

5

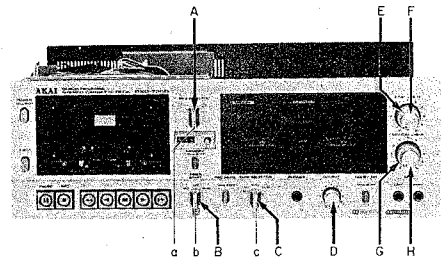

SCREWS & CONTROL KNOBS

2

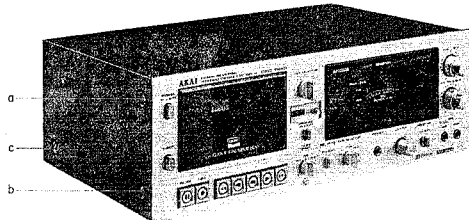

SCREWS

6

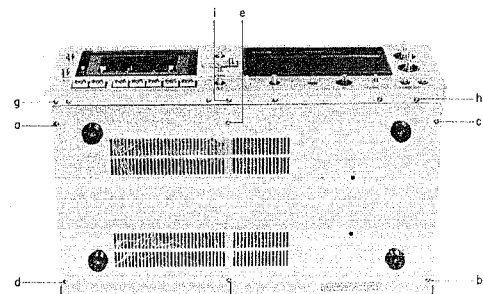

BOTTOM PLATE

SCREWS

3

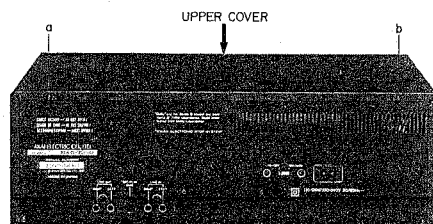

UPPER COVER

SCREWS

7

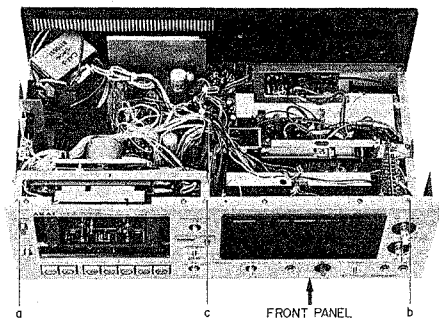

SCREWS

FRONT PANEL

4

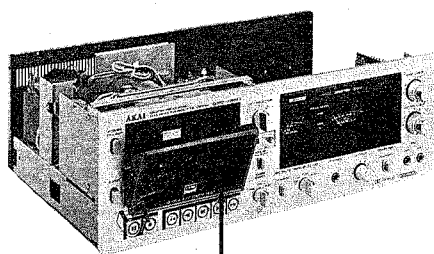

CASSETTE LID  
Pull toward you both lower-ends of holder.

8

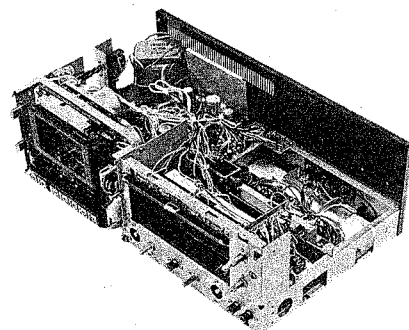

### III. CONTROLS

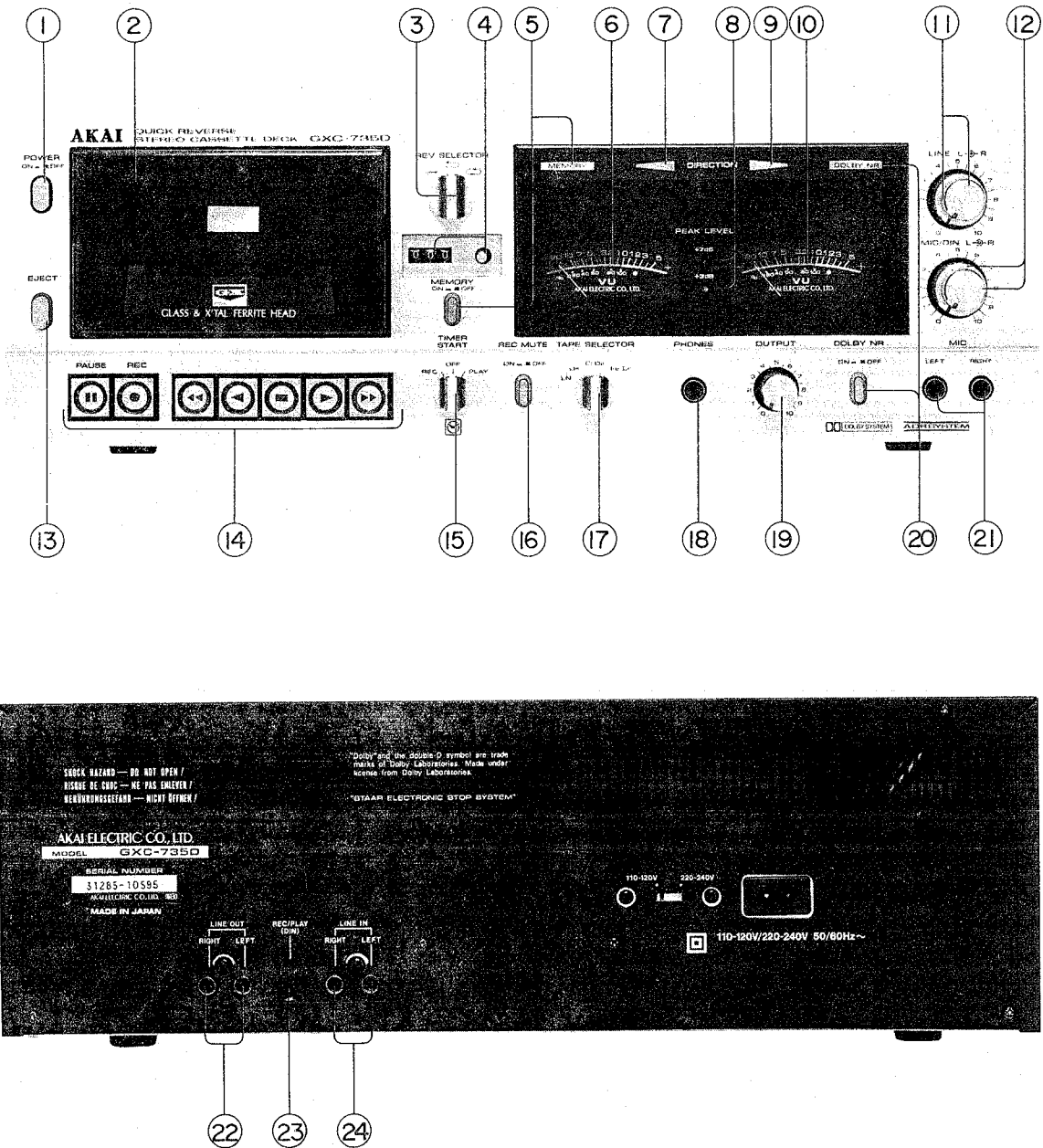

Fig. 1 Controls

- |   |  |
|---|--|
| 1. POWER SWITCH                             | 13. EJECT BUTTON                       |
| 2. CASSETTE RECEPTACLE                      | 14. MODE BUTTONS                       |
| 3. REVERSE SELECTOR                         | 15. TIMER START SWITCH                 |
| 4. INDEX COUNTER AND RESET BUTTON           | 16. REC MUTE                           |
| 5. MEMORY REWIND BUTTON AND INDICATOR LAMP  | 17. TAPE SELECTOR                      |
| 6. LEFT VU METER                            | 18. HEADPHONE JACK                     |
| 7. REVERSE DIRECTION INDICATOR              | 19. OUTPUT LEVEL CONTROL               |
| 8. PEAK LEVEL INDICATORS                    | 20. DOLBY NR SWITCH AND INDICATOR LAMP |
| 9. FORWARD DIRECTION INDICATOR              | 21. MICROPHONE JACKS                   |
| 10. RIGHT VU METER                          | 22. LINE OUTPUT JACKS                  |
| 11. LINE RECORDING LEVEL CONTROLS           | 23. DIN JACK                           |
| 12. MICROPHONE/DIN RECORDING LEVEL CONTROLS | 24. LINE INPUT JACKS                   |

# IV. PRINCIPAL PARTS LOCATION

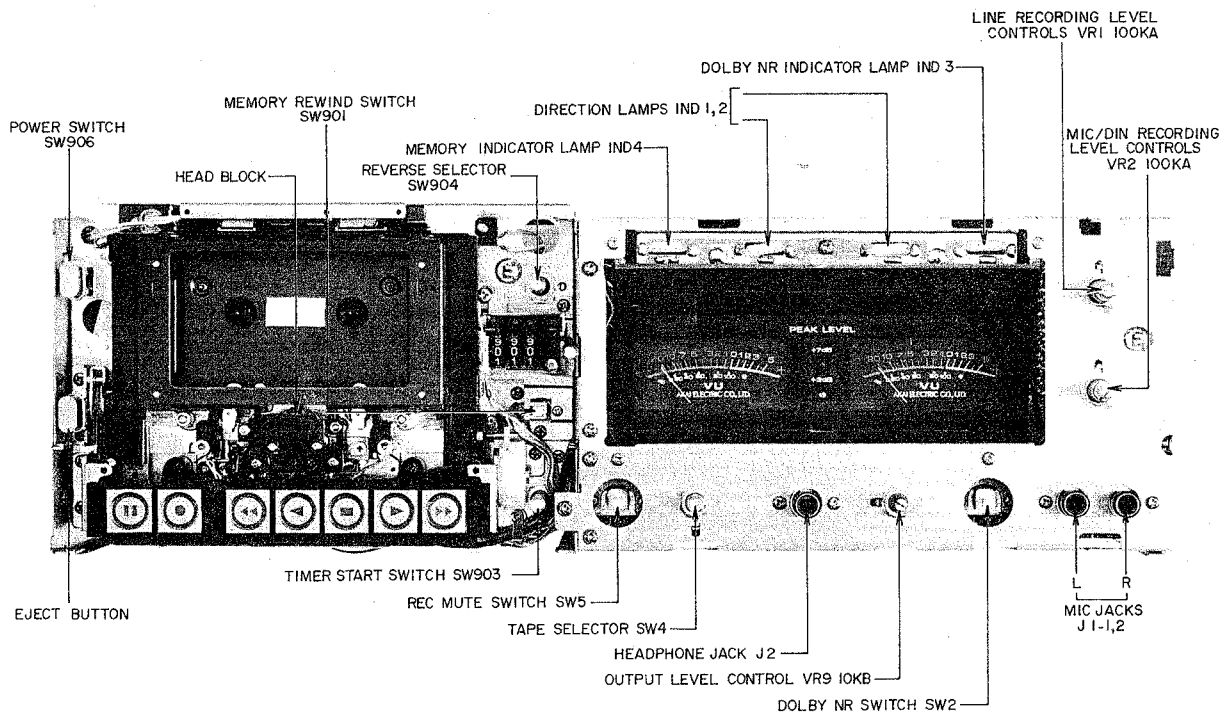

Fig. 2 Front View

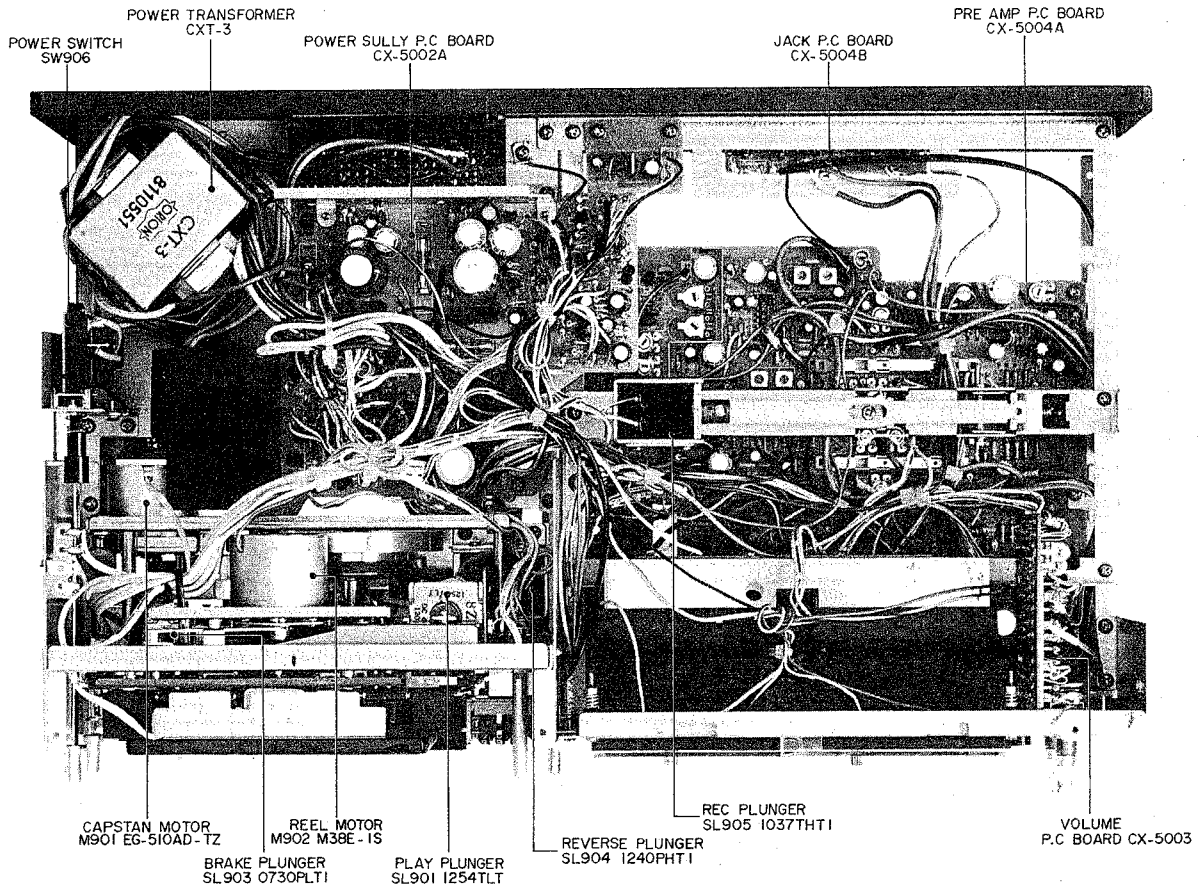

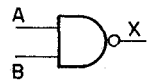
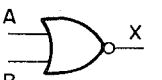

Fig. 3 Top View



# V. CIRCUIT OPERATING PRINCIPLES

	SYMBOL	TRUTH TABLE															
NOT CIRCUIT	 $X = \bar{A}$	<table border="1"> <thead> <tr> <th>A</th> <th>X</th> </tr> </thead> <tbody> <tr> <td>0</td> <td>1</td> </tr> <tr> <td>1</td> <td>0</td> </tr> </tbody> </table>	A	X	0	1	1	0									
A	X																
0	1																
1	0																
NAND CIRCUIT	 $X = \overline{A \cdot B}$	<table border="1"> <thead> <tr> <th>A</th> <th>B</th> <th>X</th> </tr> </thead> <tbody> <tr> <td>0</td> <td>0</td> <td>1</td> </tr> <tr> <td>1</td> <td>0</td> <td>1</td> </tr> <tr> <td>0</td> <td>1</td> <td>1</td> </tr> <tr> <td>1</td> <td>1</td> <td>0</td> </tr> </tbody> </table>	A	B	X	0	0	1	1	0	1	0	1	1	1	1	0
A	B	X															
0	0	1															
1	0	1															
0	1	1															
1	1	0															
NOR CIRCUIT	 $X = \overline{A + B}$	<table border="1"> <thead> <tr> <th>A</th> <th>B</th> <th>X</th> </tr> </thead> <tbody> <tr> <td>0</td> <td>0</td> <td>1</td> </tr> <tr> <td>1</td> <td>0</td> <td>0</td> </tr> <tr> <td>0</td> <td>1</td> <td>0</td> </tr> <tr> <td>1</td> <td>1</td> <td>0</td> </tr> </tbody> </table>	A	B	X	0	0	1	1	0	0	0	1	0	1	1	0
A	B	X															
0	0	1															
1	0	0															
0	1	0															
1	1	0															

0 = LOW LEVEL  
1 = HIGH LEVEL

Chart-1

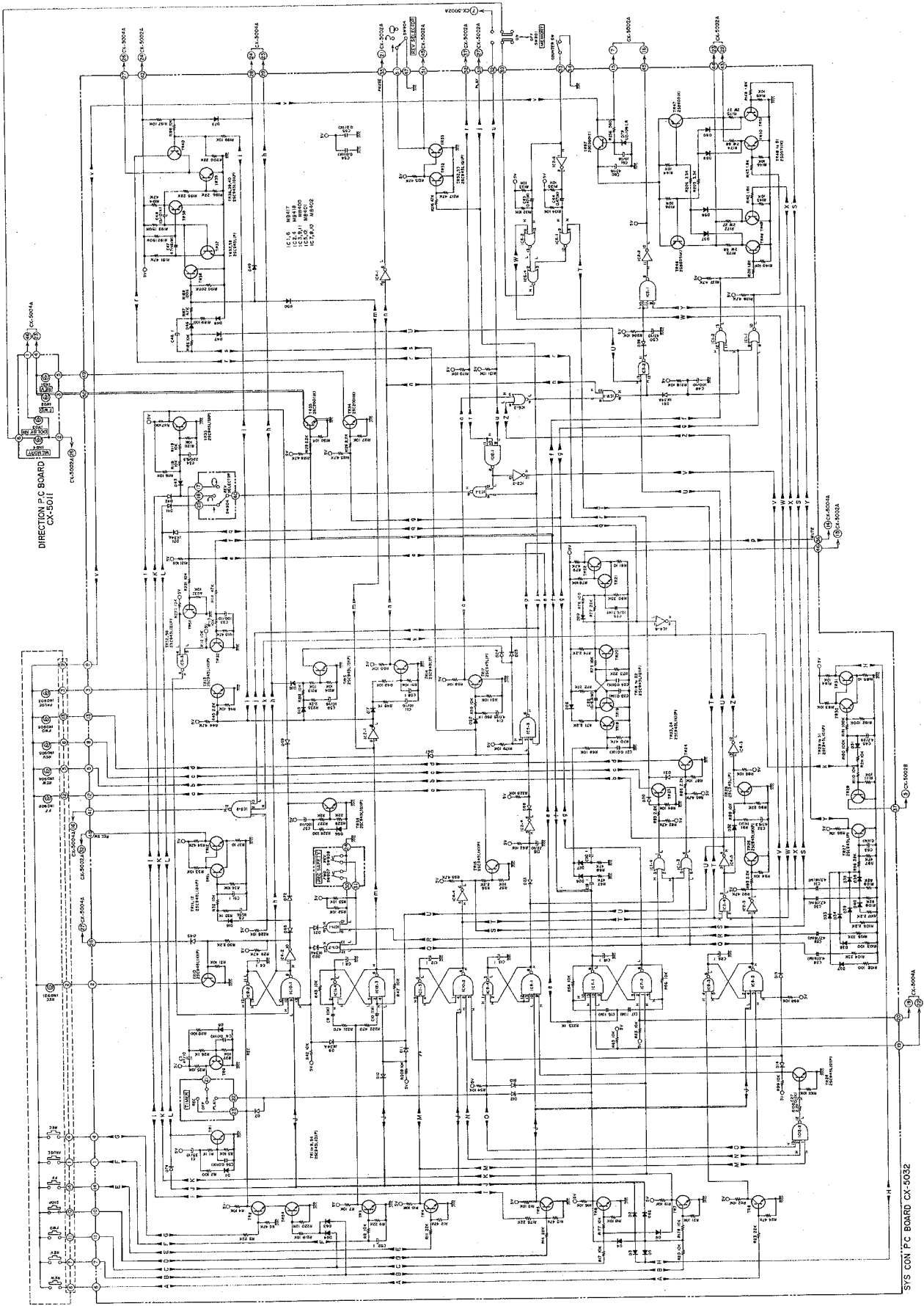

Schematic-1 STOP MODE (Sys. Con)

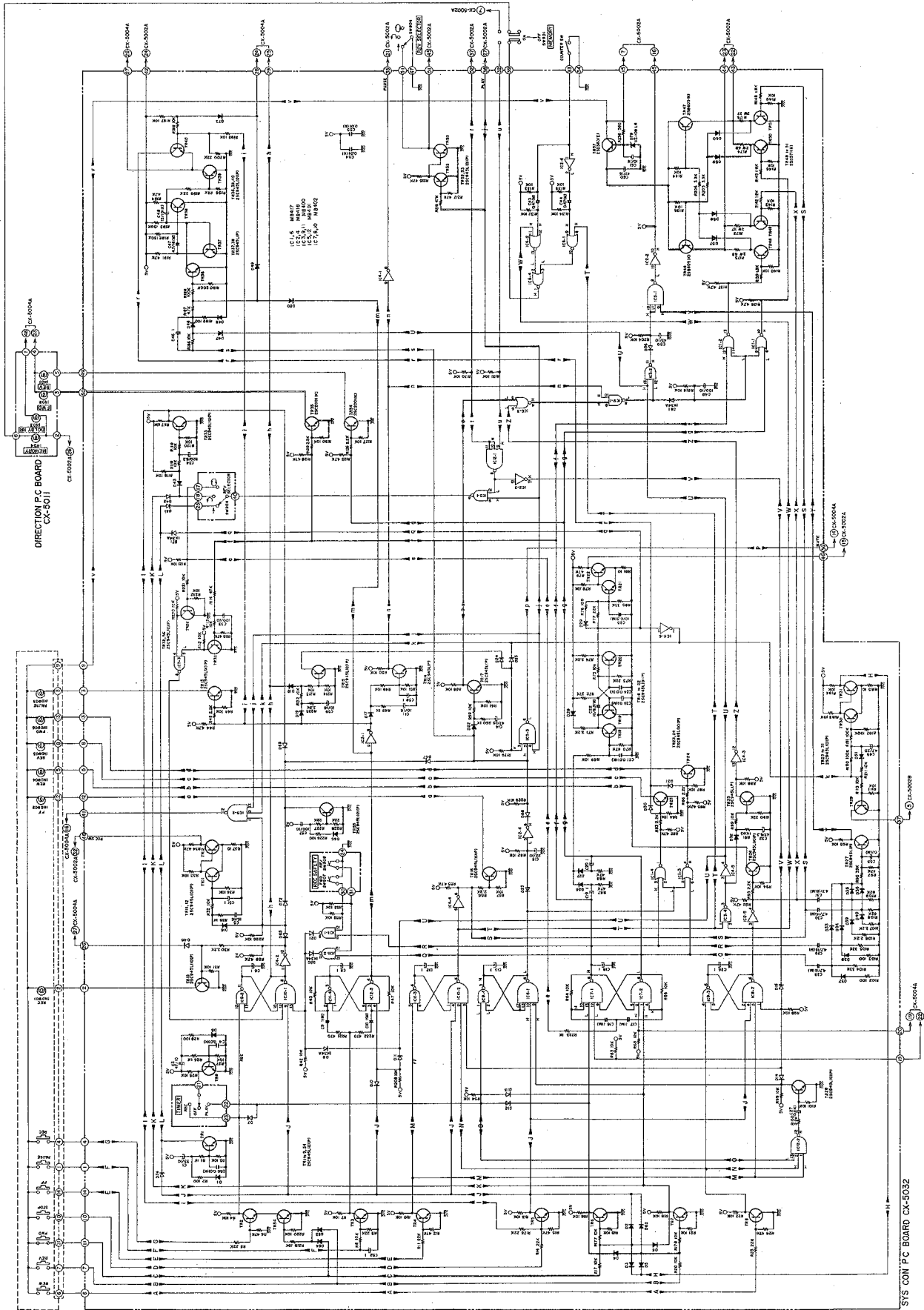

Schematic-2 FWD MODE (Sys. Con)

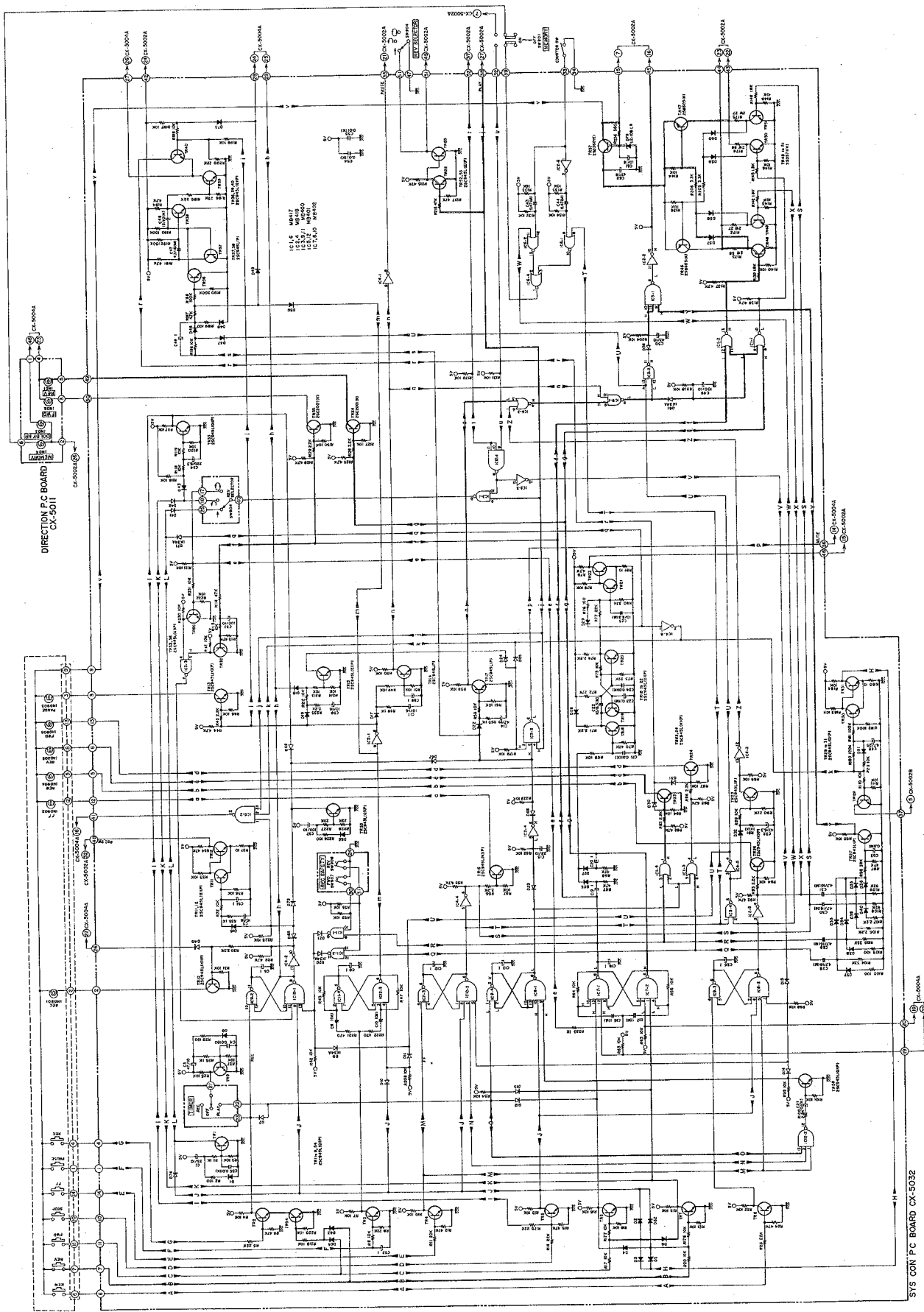

Schematic-3 REV MODE (Sys. Con)

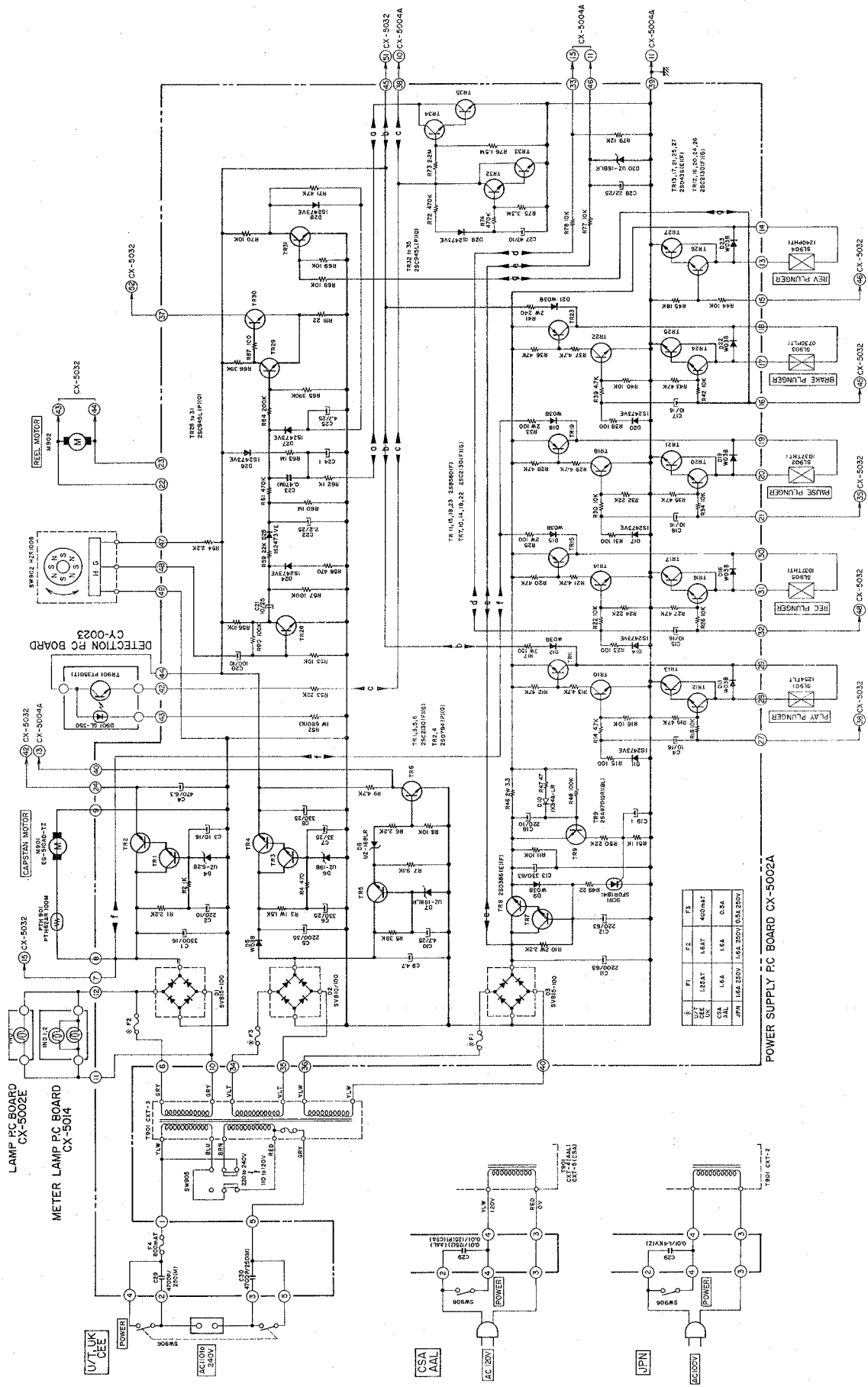

Schematic-4 FWD, REV MODE (Power Supply)

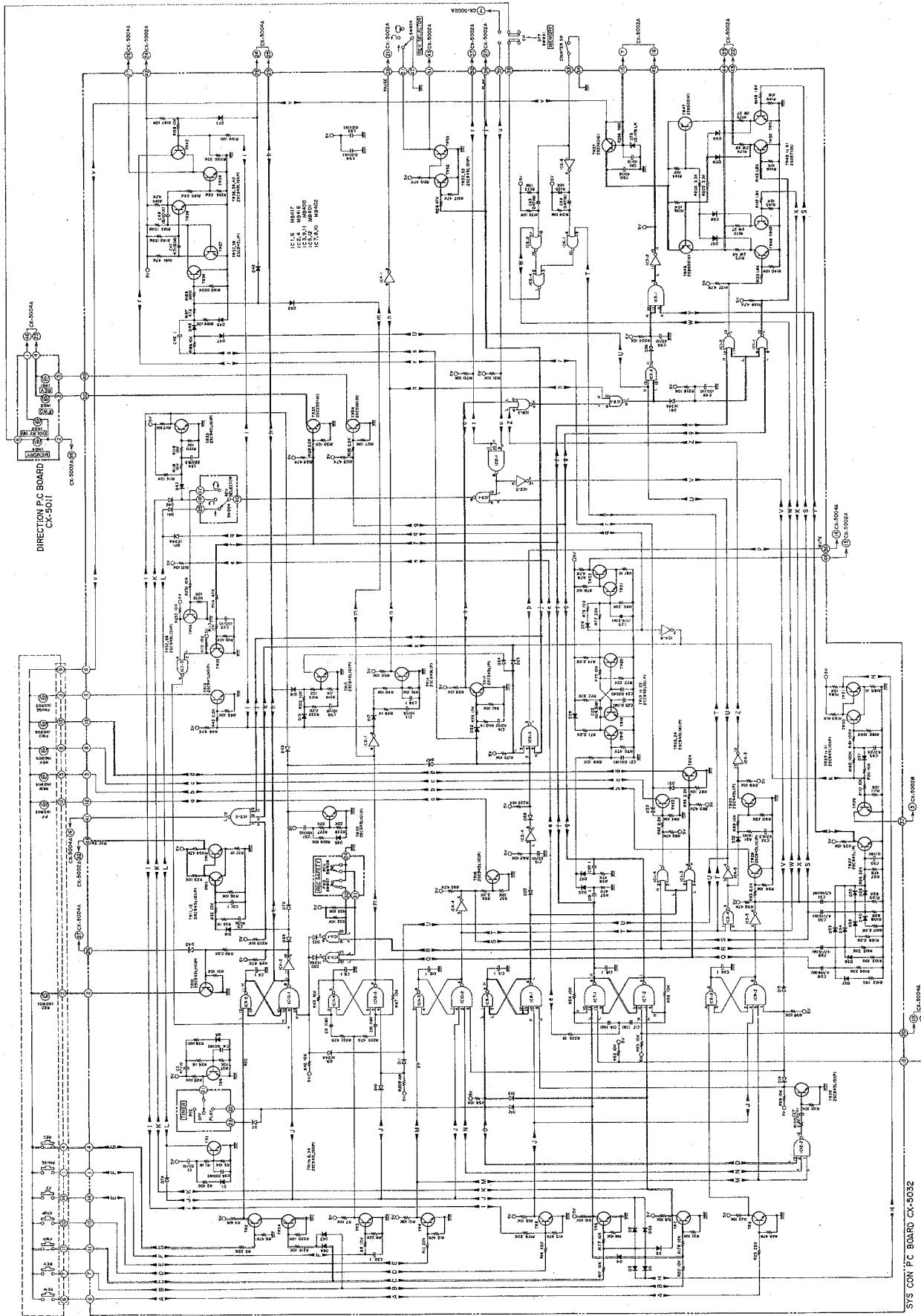

Schematic-5 REC/FWD MODE (Sys. Con)

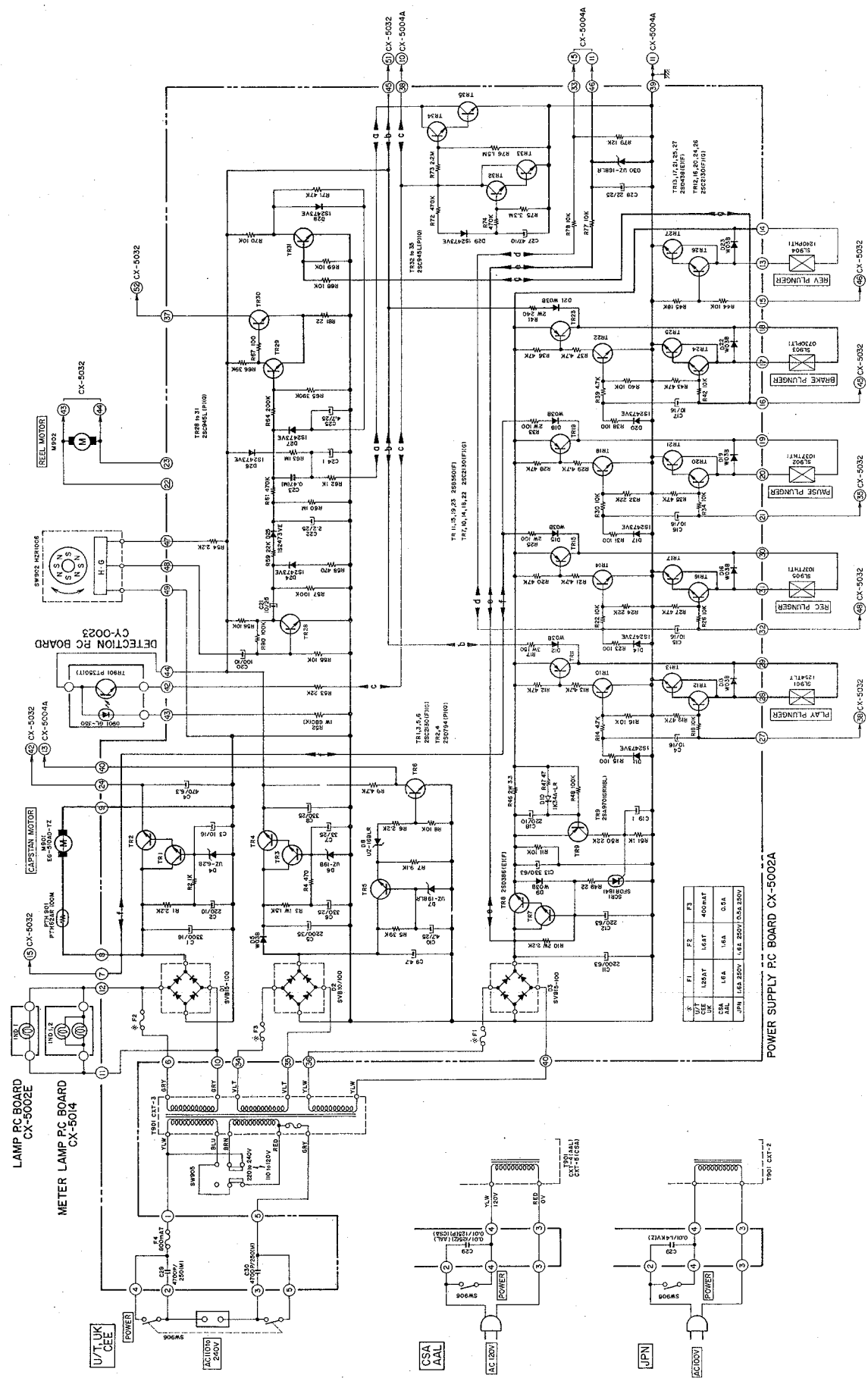

Schematic-6 REC/FWD, REV MODE (Power Supply)

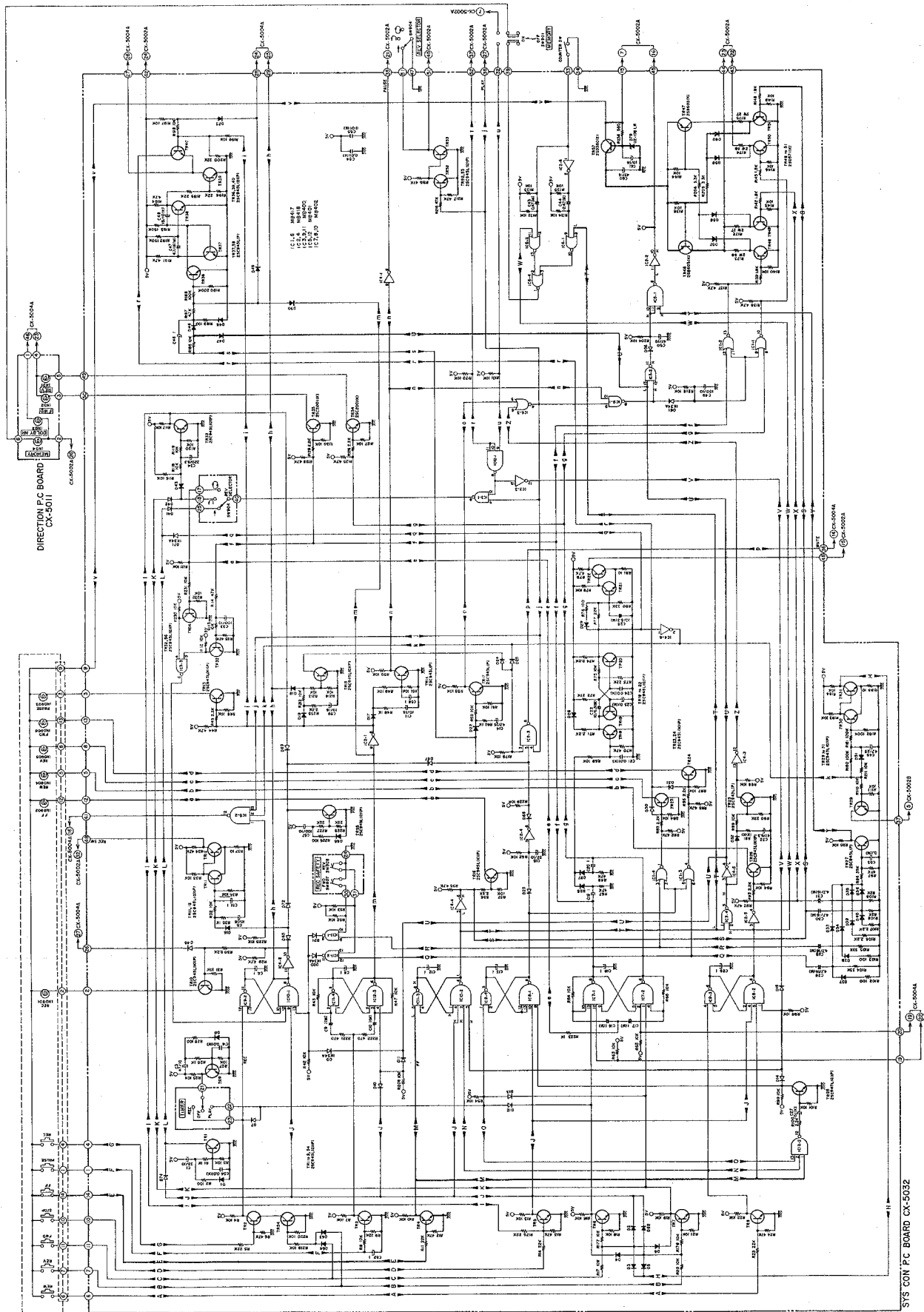

Schematic-7 FF MODE (Sys. Con)



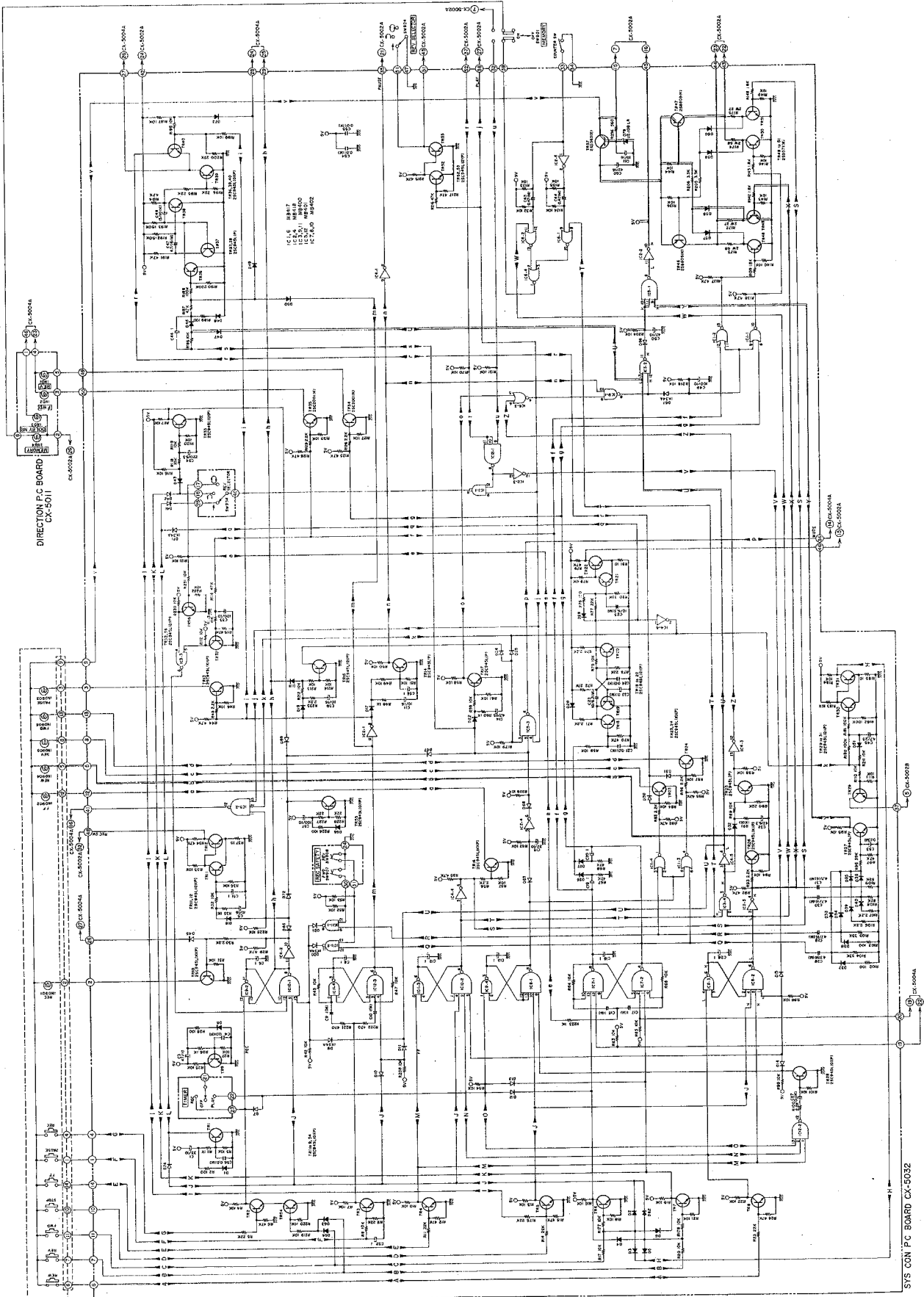

Schematic-8 REW MODE (Sys. Con)

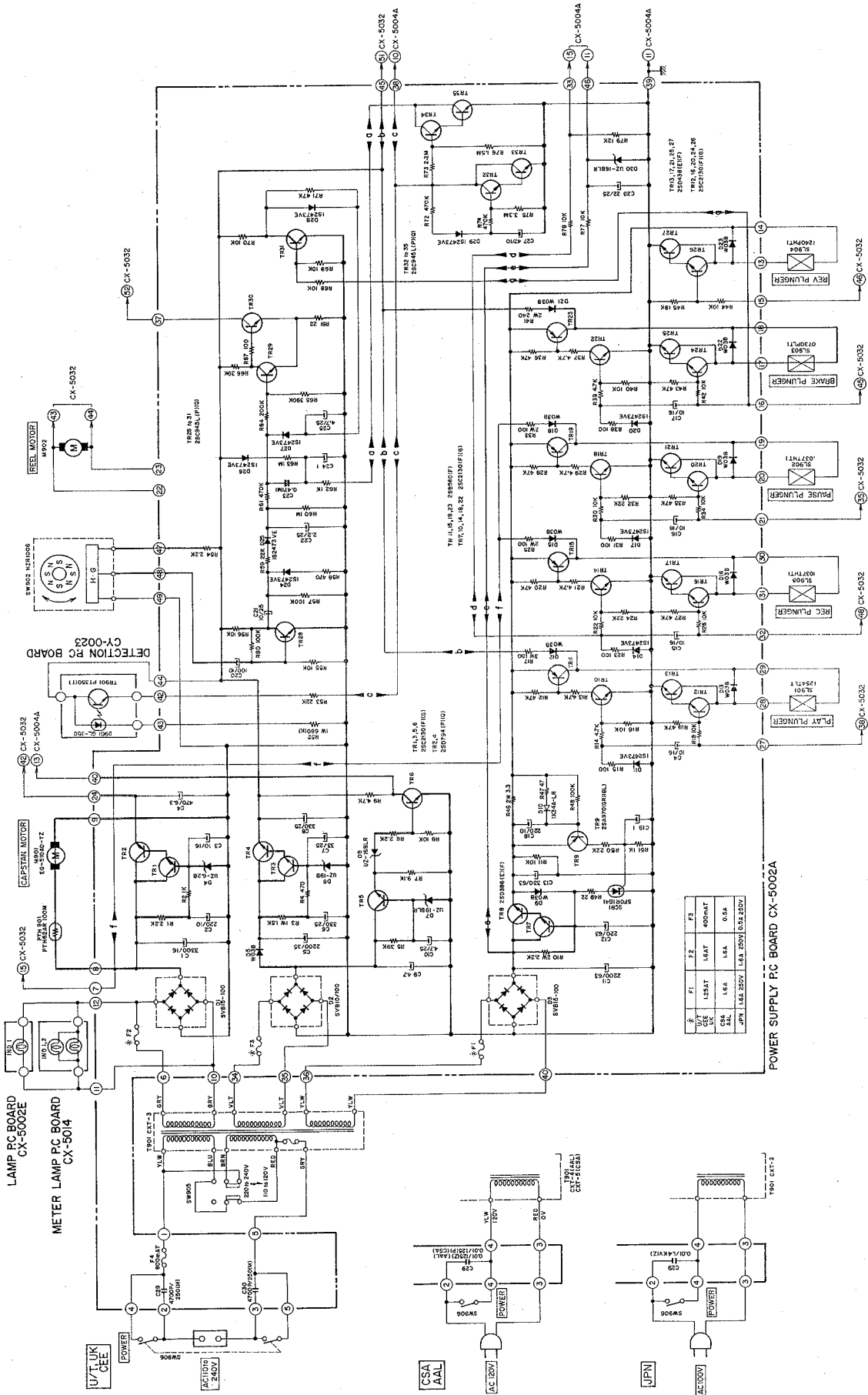

Part	Value	Part	Value
F1	1.0A	F3	400mA
F2	1.0A	F4	0.5A
U1	REG	U2	500mA
U3	REG	U4	500mA
U5	REG	U6	500mA
U7	REG	U8	500mA
U9	REG	U10	500mA
U11	REG	U12	500mA
U13	REG	U14	500mA
U15	REG	U16	500mA
U17	REG	U18	500mA
U19	REG	U20	500mA
U21	REG	U22	500mA
U23	REG	U24	500mA
U25	REG	U26	500mA
U27	REG	U28	500mA
U29	REG	U30	500mA
U31	REG	U32	500mA
U33	REG	U34	500mA
U35	REG	U36	500mA
U37	REG	U38	500mA
U39	REG	U40	500mA
U41	REG	U42	500mA
U43	REG	U44	500mA
U45	REG	U46	500mA
U47	REG	U48	500mA
U49	REG	U50	500mA
U51	REG	U52	500mA
U53	REG	U54	500mA
U55	REG	U56	500mA
U57	REG	U58	500mA
U59	REG	U60	500mA
U61	REG	U62	500mA
U63	REG	U64	500mA
U65	REG	U66	500mA
U67	REG	U68	500mA
U69	REG	U70	500mA
U71	REG	U72	500mA
U73	REG	U74	500mA
U75	REG	U76	500mA
U77	REG	U78	500mA
U79	REG	U80	500mA
U81	REG	U82	500mA
U83	REG	U84	500mA
U85	REG	U86	500mA
U87	REG	U88	500mA
U89	REG	U90	500mA
U91	REG	U92	500mA
U93	REG	U94	500mA
U95	REG	U96	500mA
U97	REG	U98	500mA
U99	REG	U100	500mA

Schematic-9 FF, REW MODE (Power Supply)

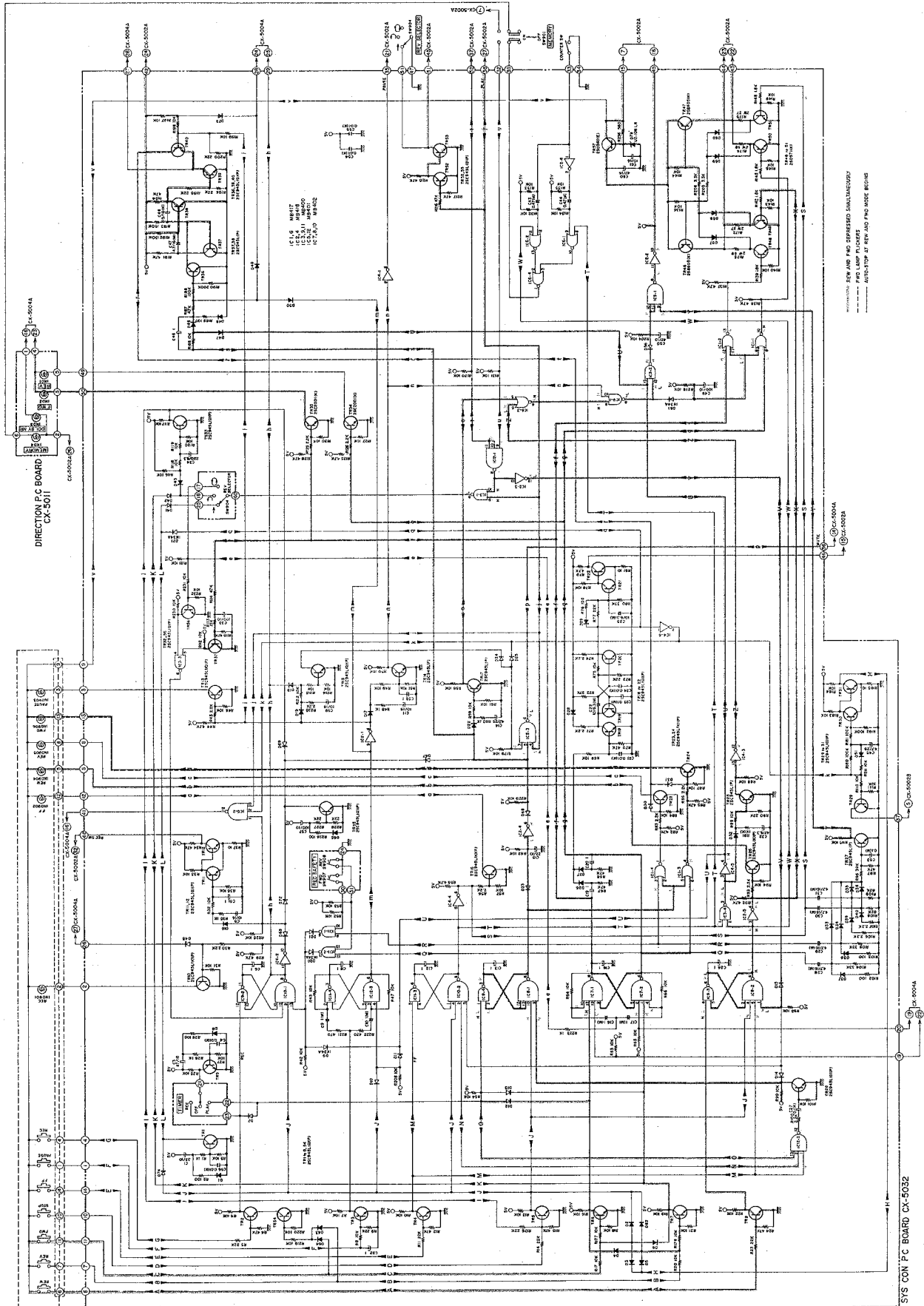

Schematic-10 REW and FWD depressed simultaneously (Sys. Con)

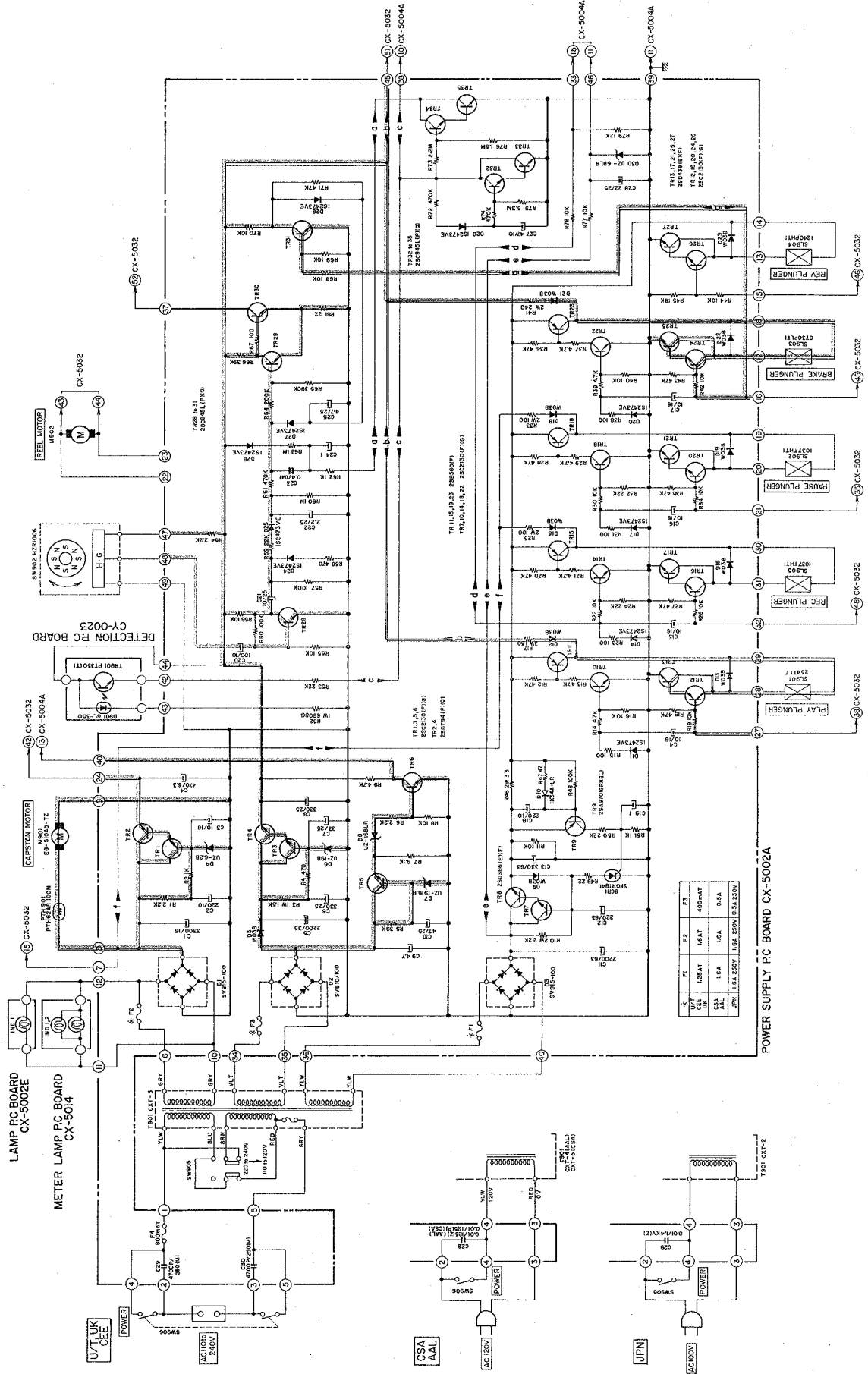

Schematic-11 REW and FWD depressed simultaneously (Power Supply)

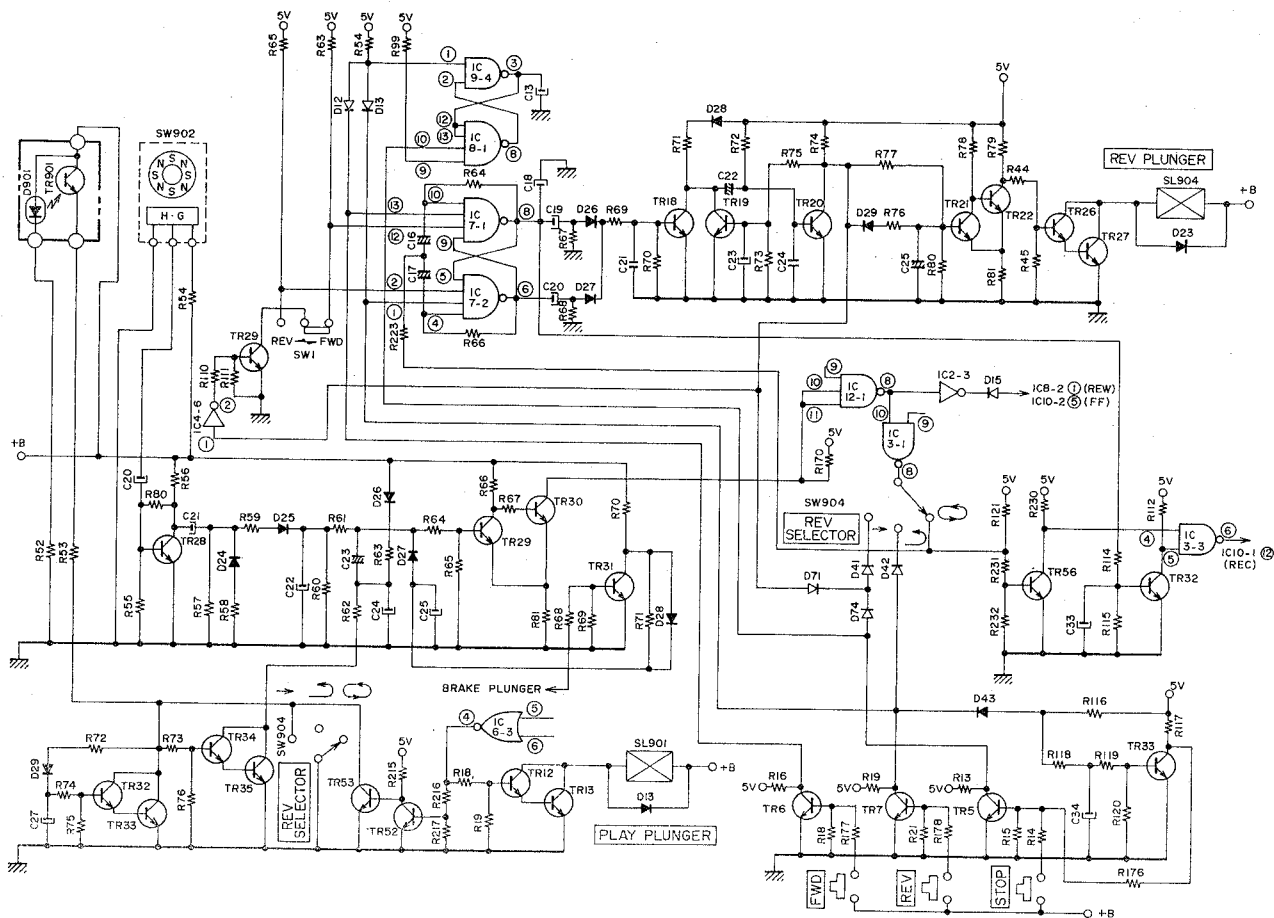

Schematic-12

## 1. AUTO-STOP & REVERSE OPERATIONS

### 1) Reverse Selector ( — ) Mode

During the tape run in the FWD or REV mode, the pulse from the revolving SW902 causes the C20 to be charged and discharged alternately.

So the base of TR28, in which the charging current of the C20 flows, goes ON and OFF alternately. This also allows the C21 to be charged and discharged, and its charging current passed through the R59, and is smoothed in the D25 and C22 and applied via the R61 and R64 into the TR29 as its base voltage, so that the TR29 and TR30 are ON and OFF respectively.

Among the three inputs NAND gate connected to the collector of TR30, inputs ⑩ and ⑪ are constantly at "H" level and input ⑨ is at "H" unless the memory operates in FF or REW mode. Therefore, the output ⑧ is at "L" level and the output ⑩ of the next gate also at "L", and the output ⑨ is at "H" in the FWD or REW mode, so that its output ⑧ is at "H" level.

As the magnetic tape is fully wound and the leader tape is fed, the TR901 of the detection tape guide goes ON due to the infrared rays from D901,

thereby causing current to flow in the R53. However, since the circuit is connected through the REV selector SW904 to the ground, the circuit has no current flowing in it and thus does not operate.

As the leader tape comes to an end and the tape transport stops, the base bias is not applied any longer to the TR28, which goes OFF. The TR31, which is always ON as long as the brake plunger is in operation, causes the potential at the base of TR29 to fall, thus turning the TR29 OFF, and the TR30 goes ON. As a result, "L" is present at ⑩ and ⑪ of the IC12-1, so the output ⑧ is at "H". In the IC3-1, both ⑩ and ⑨ are at "H", so the output ⑧ is at "L". Thus, current flows in D74 and D41 to provide "L" at ⑩ of the IC8-1. This reverse the output of the flip-flop circuit composed of IC9-4 and IC8-1, thus allowing ⑧ in IC8-1 and ③ in IC9-4 to be at "H" and "L" respectively. This enables the play plunger, brake plunger reel motor and indicator operations to be released. In this case, the FWD and REV modes are not reversed.

## 2) Reverse Selector ( ⇐ ) Mode

When a cassette tape is loaded with its beginning reached (the leader tape is visible) and the deck is set to the FWD mode, the infrared rays emitted from the D901 allows the TR901 to be ON, thereby causing current to flow in R53 and R73 to turn ON the TR34 and TR35. This, in turn, permits the C23 to discharge through R62. But the C25 cannot be fully discharged within this discharge time, so that the potential at the base of TR29 cannot fall and remains ON. Even after the C25 is fully discharged, bias is applied to the base of TR29 as mentioned in section 1) to keep it ON, for the reel continues to rotate. Then, the magnetic tape is fed and blocks the infrared rays from D901, thus turning TR901, TR34 and TR35 OFF and charging C23 through D26 and R63. And C25 remains discharged because the TR31 is ON. As the end of the magnetic tape is reached and the leader tape is fed, TR901, TR34 and TR35 are turned ON, thus allowing the C23 to discharge. This time, because the C25 remains discharged, the potential at the base of TR29 falls to turn it OFF, thereby causing the TR30 to be ON.

As a result, "L" is present at ⑩ and ⑪ of the IC12-1, so that the output ⑧ is at "H". Similarly, "H" is present at ⑩ of IC3-1 and the output ⑧ is at "L" level because ⑨ is constantly at "H" in the FWD or REV mode. Therefore, "L" is provided through D42 at ① of the IC7-2 to reverse the output of the flip-flop circuit composed by IC7-1 and IC7-2 and to thus cause ⑥ and ⑧ to be at "H" and "L" respectively, so that charging current flows into the C20 and is applied through D27 and R69 into the base of TR18. Thus, the TR18 is ON, TR20 OFF, TR21 ON, and TR22 OFF, and base bias is applied to the TR26 to turn it ON. Also the TR27 becomes ON and the reverse plunger functions instantaneously, thus enabling the mode to be REV.

In addition, current also flows from R53 into R72 and D29 while the TR901 is ON, and the TR32 and TR33 operates after charging the C27. This means that the operation is retarded by the TR34 and TR35 being ON. Therefore, when a relatively transparent magnetic tape (tape with long recording time) is fed, current flows slightly in the TR901.

This enables the potential at the base of TR34 to be lowered to a certain extent to prevent TR34 and TR35 from being put in operation and ensures that TR34 and TR35 become ON when the TR901 is turned ON by the leader tape. When the leader tape is fed during the REV mode, the TR901 becomes ON and ① of the IC7-2 is at "L" as in the FWD mode.

But, because the output of the flip-flop circuit is not reversed, the reverse plunger does not function. As the end of the leader tape is reached and

the tape transport stops, ⑧ of IC3-1 becomes at "L" level as is explained in paragraph 1). But this time, the "L" level is hold for a sufficient period unlike the case of paragraph 1), where the level is maintained only for a short period of C23's discharging time.

So that the C34 discharges to cause current to flow in R118, D43, D42 and IC3-1 ⑧, thus turning the TR33 and TR5 OFF and ON respectively and setting the deck to the STOP mode.

## 3) Reverse Selector ( ⇐ ) Mode

When the tape is transported in the FWD mode and the leader tape is fed, ⑧ in the IC3-1 is at "L" level as is described in paragraph 2). This causes the C16 and C17 to be discharged through R223.

Since ⑧ of IC7-1 and ⑥ of IC7-2 are at "H" and "L" respectively in the FWD mode ④ of IC7-2 provided with "L" through R66 attains the "L" level earlier than ⑩ of IC701 provided with "H", thereby reversing the output to allow "L" and "H" to be present at ⑧ of IC7-1 and ⑥ of IC7-2 and to thus put the deck in the REV mode. When the mode changed from REV to FWD, ⑧ of IC7-1 being at "L" causes ⑩ of IC7-1 connected to R64 to attain "L" earlier, so that the output of the flip-flop circuit is reversed to change to the FWD mode.

In the FWD/REC mode, ⑧ of IC7-1 is at "H", so the TR32 is ON and ⑤ of IC3-3 is at "L", causing output ⑥ to be at "H" level.

In the REV/REC mode, ⑧ of IC7-1 is at "L", so that the TR32 is OFF and ⑤ of IC3-3 at "H".

In normal tape transport, output ⑧ of IC3-1 is at "H", so the TR56 is ON and outputs ④ and ⑥ of IC3-3 are "L" and "H" as in the REC mode. Then, as the leader tape is fed during the REV/REC mode, the TR901 is turned ON and ⑧ of IC3-1 at "L" as in 2), so that the TR56 is turned OFF and ④ of IC3-3 becomes at "H" level. Since output ⑤ of IC3-3 is at "H" during the REV mode, its output ⑥ becomes at "L" level, thus cancelling the REC mode only, reversing the tape and changing to the FWD mode.

4) In the FF and REW modes, output ④ of IC6-3 is at "L", so that the TR52 is OFF and the TR53 ON. Therefore, even when the leader tape is fed and the TR901 becomes ON, the circuit operation does not take place.

The auto stop operation begins only after the tape transport stops at the end of tape.

5) The SW1 is provided to memorize, at turning off the power, the direction of tape transport just before turning off the power.

If the tape is transported in the FWD mode, the TR29 is ON except in the case of the reverse

---

plunger's operation, and the SW1 is set to the FWD position, so that the "L" level is provided from SW1 through TR29 to output ⑫ of IC7-1. If, under such a condition, the power is turned OFF and, then, turned ON, the slide switch SW1 remains at the same position.

So that outputs ⑫ of IC7-1 and ⑥ of IC7-2 are at "L" and ⑧ of IC7-1 is at "H", and thus the mode before turning off the power is maintained. If in this case, the timer start switch is set to PLAY position, the deck is set in the FWD playback mode.

## 2. OPERATION OF AUXILIARY CIRCUITS ON THE POWER SUPPLY P.C BOARD

- 1) In case such as an unattended recording using a timer, noises may be recorded or distortion involved if the timer goes OFF to turn OFF the power mid in the recording mode. To prevent this, the circuit composed by TR5 and TR6 is provided. When the power is ON, current flows in TR5 and passes through D8 and R6 to turn ON TR6. If the power is turned OFF, C9 and C10 immediately discharge, no current flows in TR5 and TR6 becomes OFF, while discharge current of C8 passes through R9 and is fed into ⑬ of the PRE AMP P.C BOARD.

This current then passes through D4 to turn ON TR10 and to thus stop the recording bias oscillation, while at the same time TR7 and TR6 become ON to stop of the application of input signals into the REC EQ AMP.

Because this operation is completed before the level of +B in the REC/PB AMP. OR REC EQ AMP. starts falling, no noise is recorded in the tape.

- 2) The circuit consisting of SCR1 and TR9 prevents the plunger from burning in case excessive current flows accidentally in the plunger.

TR10 and TR11 is provided to ensure that large current flows in the plunger only during the period when charge current of C14 flows upon starting the plunger's operation. Assuming that the PLAY plunger is in operation and a short-circuit occurs accidentally between the emitter and collector of TR11, large current continues flowing in SL901. But this large current causes a potential difference to be provided across the both ends of R46 so that TR9 becomes ON and the potential at the gate of SCR1 rises, thereby conducting the anode of SCR1 with its cathode and allowing current flow in them. As a result, the potential at the base of TR7 and the emitter of TR8 falls and no current flows in TR8 and TR11.

In this way, the circuit prevents excessive current in the plunger from burning the plunger. The SCR1 is reset in few seconds after the power is turned OFF.

## VI. REEL TABLE DRIVE MECHANISM

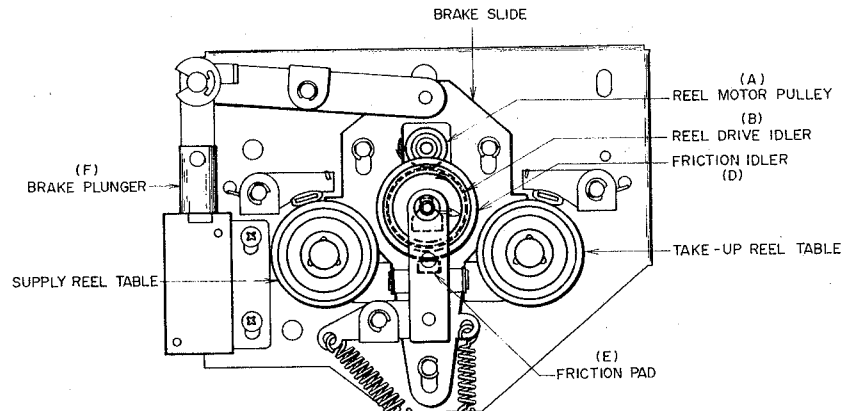

Fig. 4

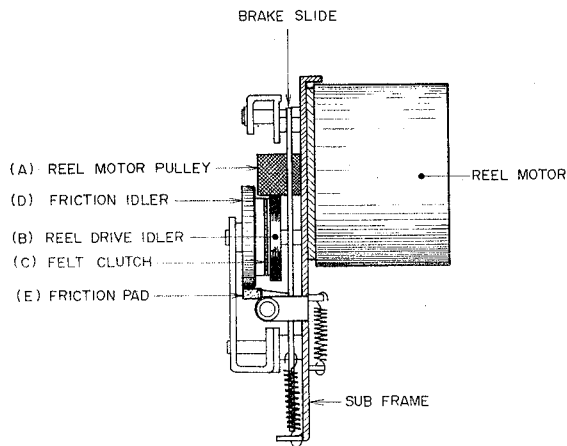

Fig. 5

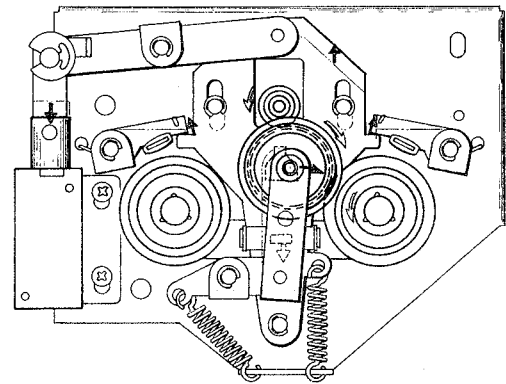

Fig. 6 PLAY. FF Mode

This mechanism employs the principle whereby the reel drive idler Fig. 4(B), Fig. 5(B) is regulated by the tape-up side and the supply side depending on the direction of the reel motor pulley rotation. Fig. 4(A), Fig. 5(A).

To ensure this transition, a felt clutch Fig. 5(C) has been placed between the reel drive idler and the friction idler on the same axis Fig. 4(D), Fig. 5(D), and a spring to pull the two idlers for friction. Damping force is applied only to the friction idler with the friction pad Fig. 4(E), Fig. 5(E) only when changing from the Stop Mode to the Tape Travel Mode. This damping force is stopped just before the tape travel.

Brake Plunger Fig. 4(F) is used for moving the mechanism to put the reel drive idler in contact with the reel table and for controlling the friction pad.



# VII. MECHANICAL ADJUSTMENT

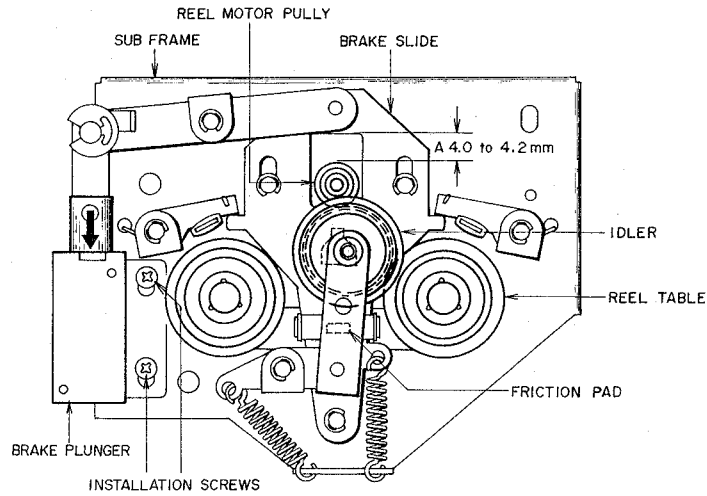

Fig. 7 Brake Plunger Installation Position Adjustment

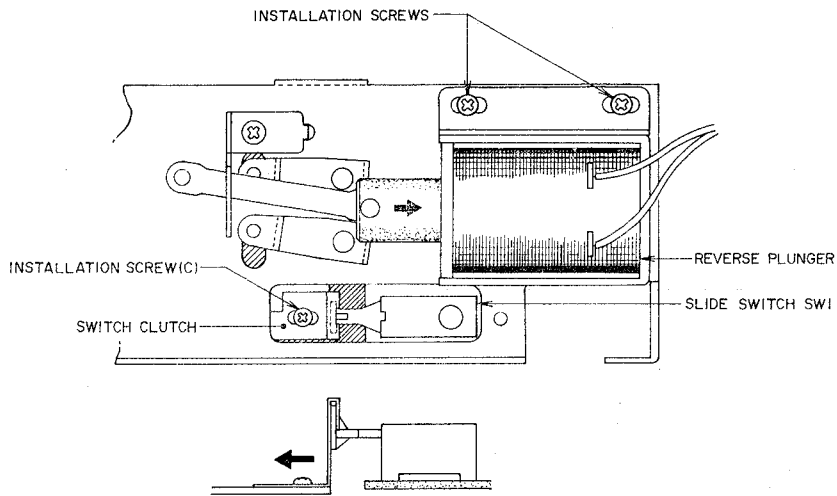

Fig. 8

## 1. Brake Plunger Installation Position

### Adjustment (Refer to Fig. 7)

Once the core of the brake plunger has been pushed in the direction of the arrows, (the brake plunger is in operation) loosen the two installation screws and alter their position until gap A is 4.0 to 4.2 mm. After adjustment, paint lock the screws.

## 2. Reverse Plunger Installation Position

### Adjustment (Refer to Figs. 8, 9)

Having switched from forward to reverse modes, (the reverse plunger is in operation) loosen the two installation screws and adjust their position until the gap A (Fig. 9(a)) between the lock prop and the reverse slide lever becomes 0.3 mm.

Next, switch from reverse to forward and check that the lock prop has been locked to part B (Fig. 9(b)). There need not be gap.

After adjustment, paint lock the two reverse plunger installation screws.

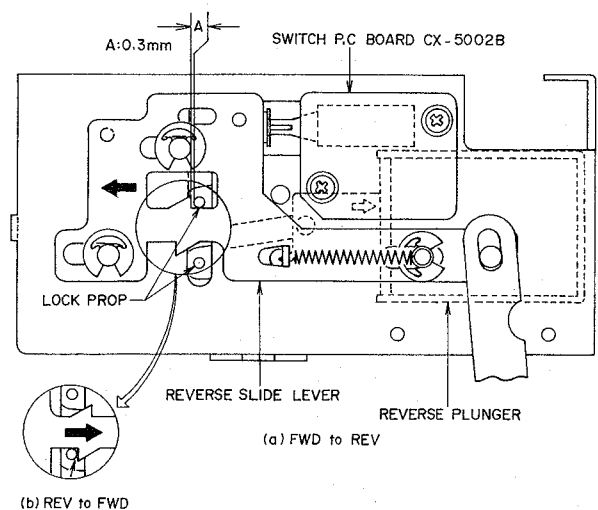

Fig. 9

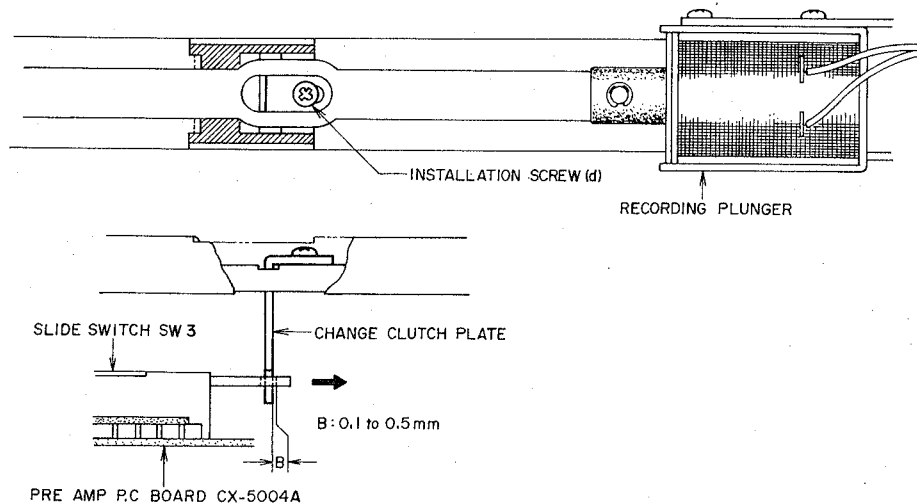

Fig. 10

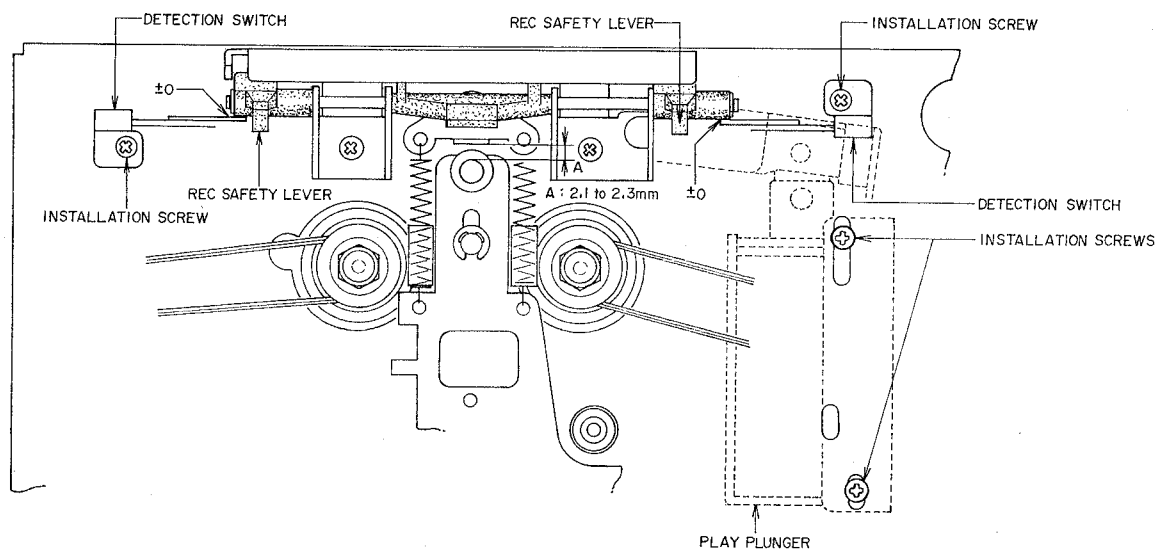

Fig. 11

### 3. Slide Switch Operating Position Adjustment (Refer to Figs. 8, 10)

- a) Put into reverse mode. Loosen installation screw(c) in Fig. 8 and move the switch clutch in the direction of the arrows and having pulled the slide switch SW1 out to its fullest extent, tighten installation screw(c).
- b) Put in forward mode. Loosen installation screw(d) in Fig. 10 and move the switch clutch board in the direction of the arrows, then pull the slide switch SW3 out to its fullest extent. Release only the switch clutch board 0.1 to 0.5 mm and tighten installation screw(d).

### 4. Play Plunger Installation Position Adjustment (Refer to Fig. 11)

Put in either forward or reverse modes (the play plunger operates), loosen the two installation screws and adjust the play plunger's position so that gap A (Fig. 11) is 2.1 to 2.3 mm. After adjustment, paint lock the installation screws.

### 5. Recording Detection Switch Position Adjustment (Refer to Fig. 11)

Without inserting a cassette pack, loosen the installation screws with the detection switch underpressed and no gap between the recording safety lever and the detection switch and adjust the position of the detection switch. Adjustment should be made on both forward and reverse sides.

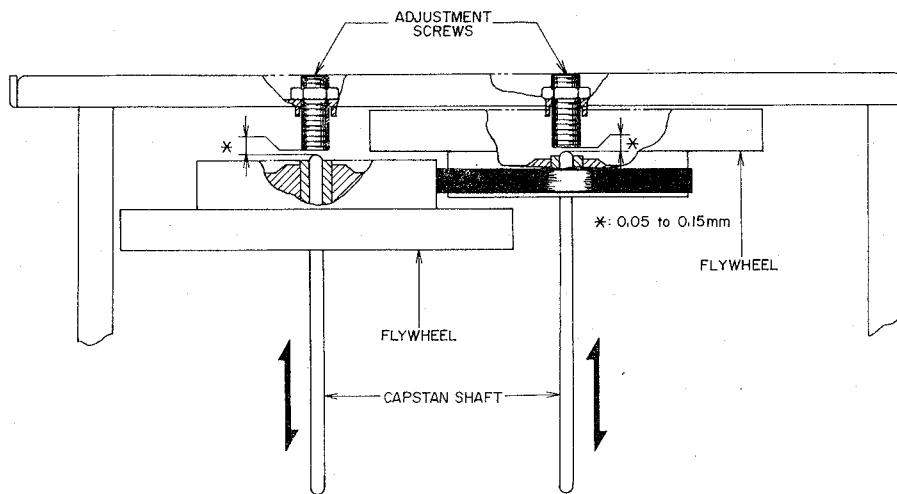

Fig. 12

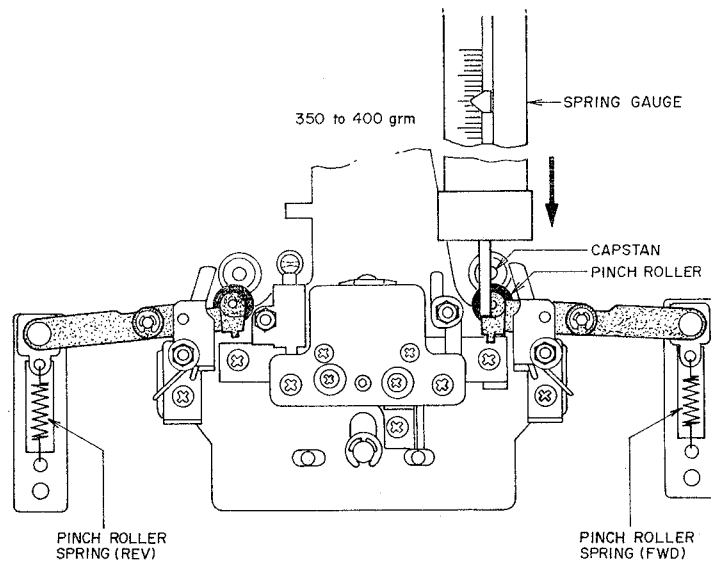

Fig. 13

## 6. Flywheel Loose Play Adjustment

(Refer to Fig. 12)

Adjust by turning the adjustment screws so that there is a loose play of 0.05 to 0.15 mm when the capstan is raised or lowered in the direction of the arrows. After adjustment paint lock the adjustment screws.

## 7. Pinch Roller Contact Pressure Measurement

(Refer to Fig. 13)

Put in forward mode. Push pinch roller arm down with the spring gauge push the pinch roller 1–2 mm from the capstan and release slowly.

Read the spring gauge. At the moment the pinch roller touches the capstan and begins to rotate.

Specified contact pressure measurement of 350 to 400 gm.

If there is no measurement obtained, replace the pinch roller spring. Do the same for the reverse side.

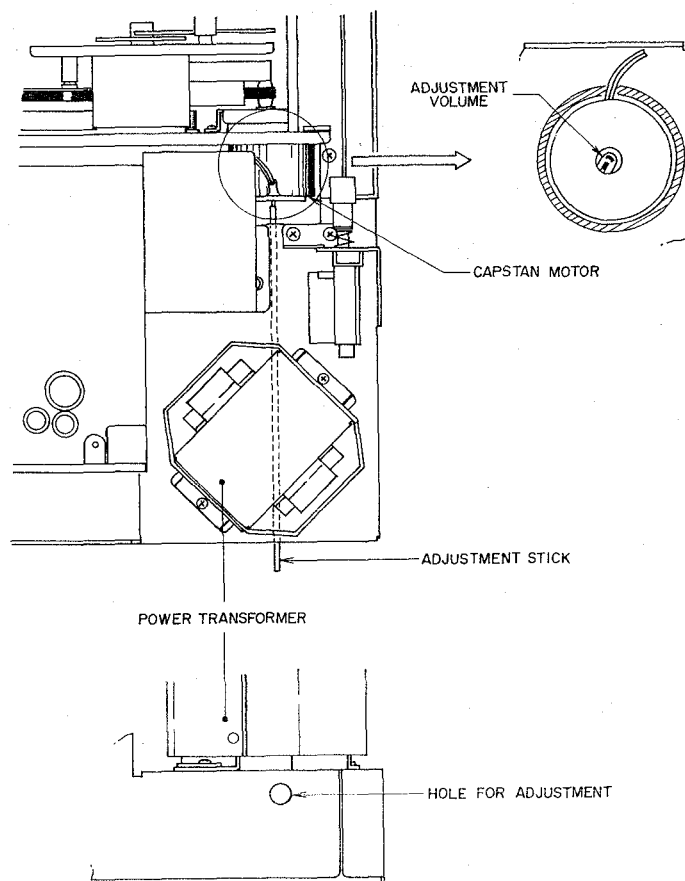

Fig. 14 Tape Speed Adjustment

#### 8. Winding Torque Measurement in Each Mode

Insert cassette torque meter and measure in each mode. For fast forward and rewind measure at the end of the tape when the tape has stopped running. The specified torque is:

Forward, Reverse : 35 to 55g-cm.  
Fast Forward, Rewind : 70 to 120g-cm.

#### 9. Tape Speed Adjustment (Refer to Fig. 14)

Attach frequency counter to LINE OUT jack and playback the 1,000 Hz test tape. The frequency counter reading should be 1,000 Hz  $\pm$  1%.

To adjust, first remove the rear panel. The adjustment hole is situated underneath the power transformer. Insert a long adjustment screw driver into this hole and adjust the speed by turning the speed adjustment volume which is at the center of the bottom of the capstan motor.

When using a driver, cover the metal part with a plastic tube and be very careful not to short the various parts of the adjustment volume or Sys. Con P.C Board.

# VIII. HEAD ADJUSTMENT

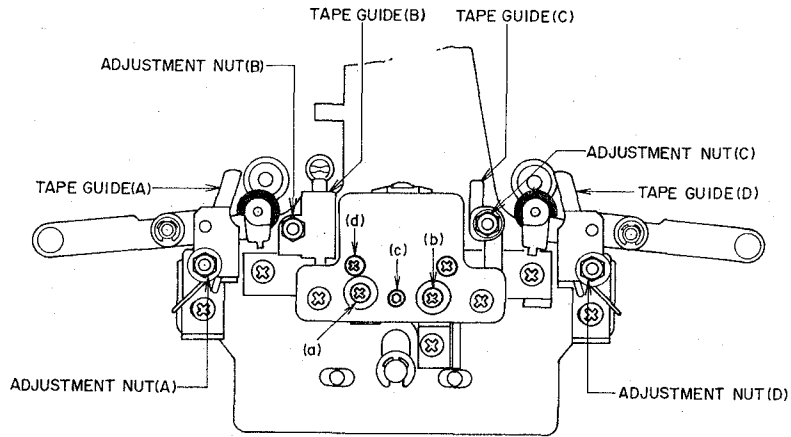

Fig. 15

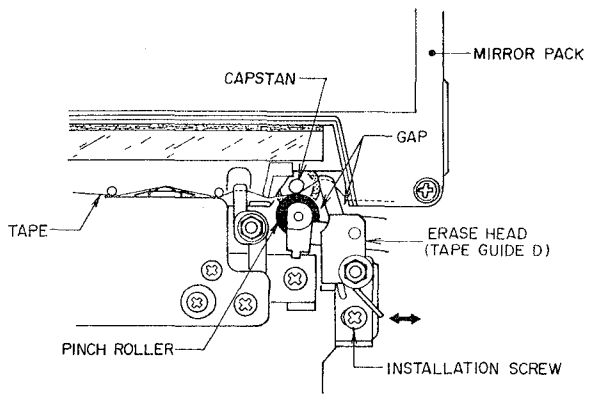

Fig. 16

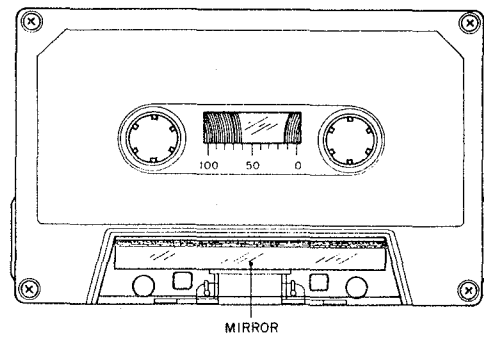

Fig. 18

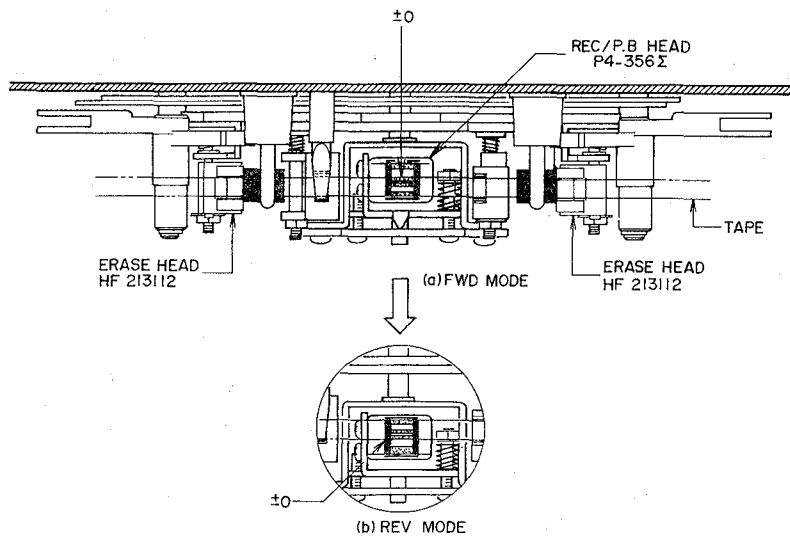

Fig. 17

## 1. Tape Guide Height Adjustment

(Refer to Figs. 15, 16, 18)

- 1) When using an ordinary cassette, the tape guides and heads, etc. are not visible. As shown in Fig. 18 use a cassette tape from which part of the cassette case has been cut out and a mirror installed easy visibility of the head area when making tape guide height adjustment.
- 2) Adjust tape guides (B) and (C) taking tape guides (A) and (D) as the standard heights. Carry out height adjustment of tape guide (C) in the forward mode and tape guide (D) in the reverse mode, making the tape run smooth in either mode without catching the tape guides.
- 3) Normally, adjustment should not be carried out for tape guides (A) and (D) serving at the same time as an erase head.

If replacement etc. requires their adjustment, proceed as follows:

In the case of replacing the tape guide (D), first install the tape guide temporarily on a certain height. Then, load a mirror cassette 1) and set the deck in the FWD mode or depress the play plunger by hand to raise the head block. Loosen the retaining screw and shift the tape guide in the direction of the arrow to adjust the height in such a way that the tape guide does not contact the pinch roller or the tape is not caught between the tape guide and the cassette.

In this case, bring the guide as close as possible to the pinch roller to provide a large clearance to the cassette. It should be also adjusted so that the head can move upward without contacting the pinch roller. After completing the above adjustment, adjust only the height of the tape guide (D) until the tape is transported smoothly both in FWD and REV modes without being caught into the tape guide.

In this case, do not adjust other tape guides.

In the case of replacing the tape guide (A), perform the adjustment of installation position in the REV mode. The height adjustment should be carried out by transporting the tape in both directions.

Adjust the tape guide (A) only.

## 2. REC/PB Head Tilt Adjustment

(Refer to Figs. 15, 18)

- 1) Set 1-1) cassette pack and let the tape run. Adjust with screw (c) in Fig. 15 so that the tape touches on face of the REC/PB head evenly.

## 3. Recording/Playback Head Height

Adjustment (Refer to Figs. 15, 17, 18)

- 1) Set 1-1) cassette pack and advance past the leader tape in the forward mode. Adjust screw (a) in Fig. 15 so that the upper part of the tape meets the upper part of the left channel core of the head. Then put into reverse mode. Adjust screw (b) in Fig. 15 so that the lower part of the tape meets the lower part of the left channel core of the head.
- 2) Attach an AC voltmeter to the LINE OUT jack. Playback the head height adjustment tape (4 track, 1,000 Hz) in the forward mode and adjust minutely with screw (a) in Fig. 15 until the output level for both the right and left channels reaches maximum (the voltmeter reads maximum). Carry out exactly the same minute adjustment with screw (b) in Fig. 15 for the reverse mode.

## 4. Recording/Playback Head Azimuth

Adjustment (Refer to Fig. 15)

- 1) Playback the azimuth adjustment tape (10 kHz) in the forward mode and adjust screw (d) in Fig. 15 until the output level of both channels reaches maximum (the AC voltmeter registers maximum).
- 2) Put in reverse mode and check that the output level is the same as in the forward mode. If different, adjust with screw (d) in Fig. 15 until the level is the same in both modes.
- 3) After adjustment, check both the head height and the azimuth.

### NOTES:

1. After adjustment, paint lock tape guide adjustment nuts, and head adjustment screws, (c), (d).
2. Be sure to clean the heads prior to head adjustment.
3. Be careful not to use a magnetized driver or other magnetized tools in the vicinity of the heads.
4. Be sure to demagnetize the heads with a Head Demagnetizer before and after head adjustment.

# IX. AMPLIFIER ADJUSTMENT

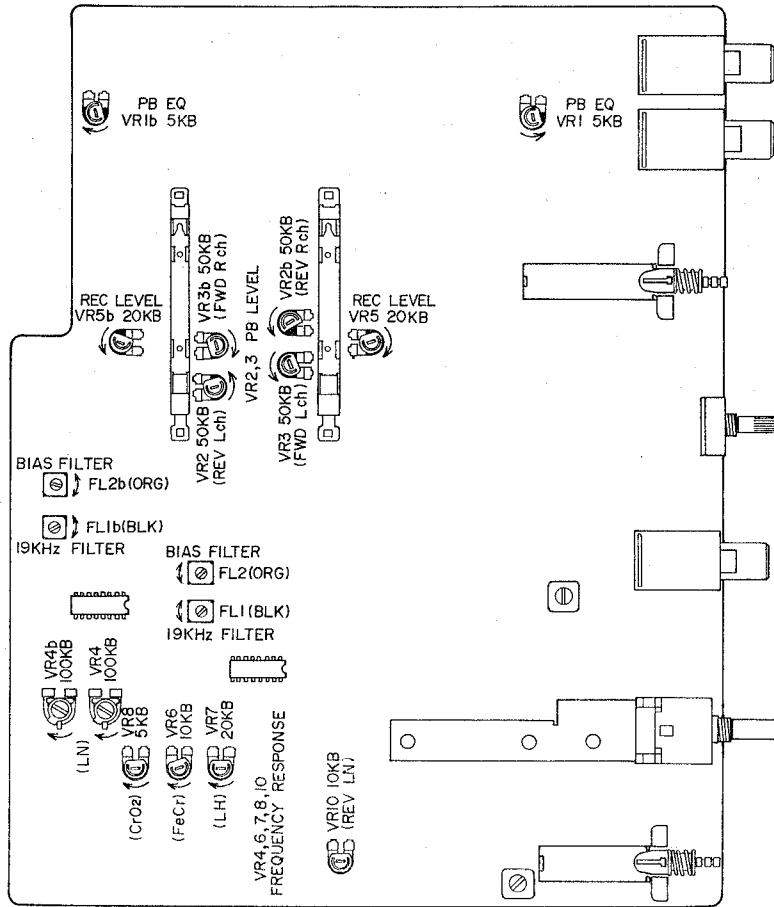

Fig. 19 Pre Amp P.C Board CX-5004A

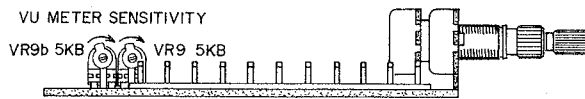

Fig. 20 Volume P.C Board CX-5003

Step	Adjustment Item	Test Tape Supply Signal	Mode	Adjustment Point	Result	Remarks
1	FWD Playback Level	333Hz 0 VU Test Tape	FWD	VR3 50 kB	-5.5 ± 0.5 dBm (410 mV)	
2	REV Playback Level	333Hz 0 VU Test Tape	REV	VR2 50 kB	-5.5 ± 0.5 dBm (410 mV)	
3	VU Meter Sensitivity	333Hz 0 VU Test Tape	FWD	VR9 5 kB	0 VU indication	
4	Playback equalizer	10kHz Test Tape	FWD	VR1 5 kB	-19.5 ± 0.5 dBm	
5	LN Position Frequency Response (FWD)	Low Noise Blank Tape 1,000Hz, 10,000Hz, -25.5 dBm recording	FWD- REC/PLAY	VR4 100 kB	1,000Hz, 10,000Hz, flat response	
6	LH Position Frequency Response (FWD)	LH Blank Tape 1,000Hz, 10,000Hz, -25.5 dBm recording	FWD- REC/PLAY	VR8 20 kB	1,000Hz, 10,000Hz, flat response	Set Tape Selector to LH position
7	CrO <sub>2</sub> Position Frequency Response (FWD)	CrO <sub>2</sub> Blank Tape 1,000Hz, 10,000Hz, -25.5 dBm recording	FWD- REC/PLAY	VR7 5 kB	1,000Hz, 10,000Hz, flat response	Set Tape Selector to CrO <sub>2</sub> position
8	FeCr Position Frequency Response (FWD)	FeCr Blank Tape 1,000Hz, 10,000Hz, -25.5 dBm recording	FWD- REC/PLAY	VR6 10 kB	1,000Hz, 10,000Hz, flat response	Set Tape Selector to FeCr position
9	LN Position Frequency Response (REV)	Low Noise Blank Tape 1,000Hz, 10,000Hz, -25.5 dBm recording	REV- REC/PLAY	VR10 10 kB	1,000Hz, 10,000Hz, flat response	Set Tape Selector to LN position
10	LH, CrO <sub>2</sub> , FeCr Each Position Frequency Response Confirmation (REV)	LH, CrO <sub>2</sub> , FeCr Blank Tape 1,000Hz, 10,000Hz, -25.5 dBm recording	REV- REC/PLAY		1,000Hz, 10,000Hz, flat response	(Refer to NOTE 6)
11	Recording Level	Lw Noise Blank Tape 1,000Hz, -5.5 dBm recording	FWD- REC/PLAY	VR5 20 kB	-5.5 ± 0.5 dBm (410mV)	



Step	Adjustment Item	Test Tape Supply Signal	Mode	Adjustment Point	Result	Remarks
12	Distortion Factor Confirmation	1,000Hz, -5.5 dBm recording	FWD-REC/PLAY REV-REC/PLAY	LN: Less than 1.0% LH: Less than 1.0% CrO <sub>2</sub> : Less than 1.5% FeCr: Less than 1.5%		(Refer to NOTE 7)
13	Blas Filter	No Signal Input	REC	FL2 D07-002 (ORG)	Minimum AC Voltmeter indication	MIC REC LEVEL Control at Maximum (Refer to NOTE 8)
14	19 kHz Filter	1,900 kHz From an oscillator	REC	FL1 D07-001 (BLK)	Minimum AC Voltmeter indication	DOLBY N.R. Switch to ON (Refer to NOTES 8, 9)

Chart-2 Amplifier Adjustment

- NOTES:**
1. Output Level Control should be at maximum.
  2. Because each of these adjustment are vital to perfect Dolby N.R. circuit operation, be sure that they are carried out with as little error as possible.
  3. Except for Steps 6 thru 7 and 10, 12 set tape selector to Low Noise position.
  4. Except for Step 14, set Dolby N.R. switch to OFF position.
  5. Use the following cassette measuring tapes:
    - LN tape: Fuji FL C-60
    - LH Tape: Maxell UD C-60
    - CrO<sub>2</sub> Tape: TDK SA C-60
    - FeCr Tape: SONY Duad C-60
  6. If a flat characteristic cannot be obtained from 1,000 Hz to 10,000 Hz at LH, CrO<sub>2</sub>, or FeCr positions, carry out adjustment step 9 once again.
  7. If it does not comply with the specifications, repeat Steps 5 to 11 and re-adjust.
  8. Unless the core is moved intentionally this adjustment is not necessary.
  9. Adjust the oscillators frequency to give a frequency counter reading of 19.00 kHz.

## X. DC RESISTANCE OF VARIOUS COILS

---

Part Name	Code	DC Resistance
REC/PB Head	P4-356 sigma	405 ohms $\pm$ 10%
Erase Head	HF 213112	2.8 ohms
Play Plunger Solenoid	1254 TLT	120 ohms $\pm$ 10%
Reverse Plunger Solenoid	1240 PHTI	60 ohms $\pm$ 10%
REC Plunger Solenoid	1037 THTI	120 ohms $\pm$ 10%
Pause Plunger Solenoid	1037 THTI	120 ohms $\pm$ 10%
Brake Plunger Solenoid	0730 PLTI	145 ohms $\pm$ 10%

Chart-3

## XI. CLASSIFICATION OF VARIOUS P.C BOARDS

---

### 1. P.C BOARD TITLES AND IDENTIFICATION NUMBERS

P.C Board Title	P.C Board Number
Pre Amp P.C Board	CX-5004A
Sys. Con P.C Board	CX-5032
Power Supply P.C Board	CX-5002A
Volume P.C Board	CX-5003
Jack P.C Board	CX-5004B
Direction P.C Board	CX-5001
Meter Lamp P.C Board	CX-5014
Lamp P.C Board	CX-5002E
Switch P.C Board	CX-5002B
Peak P.C Board	CX-5002C
Relay P.C Board	CX-5002D
Detection P.C Board	CY-0023

Chart-4

## 2. COMPOSITION OF VARIOUS P.C BOARDS

- 1) PRE AMP P.C BOARD CX-5004A (3ED), JACK P.C BOARD CX-5004B,  
SWITCH P.C BOARD CX-5002B & RELAY P.C BOARD CX-5002D.

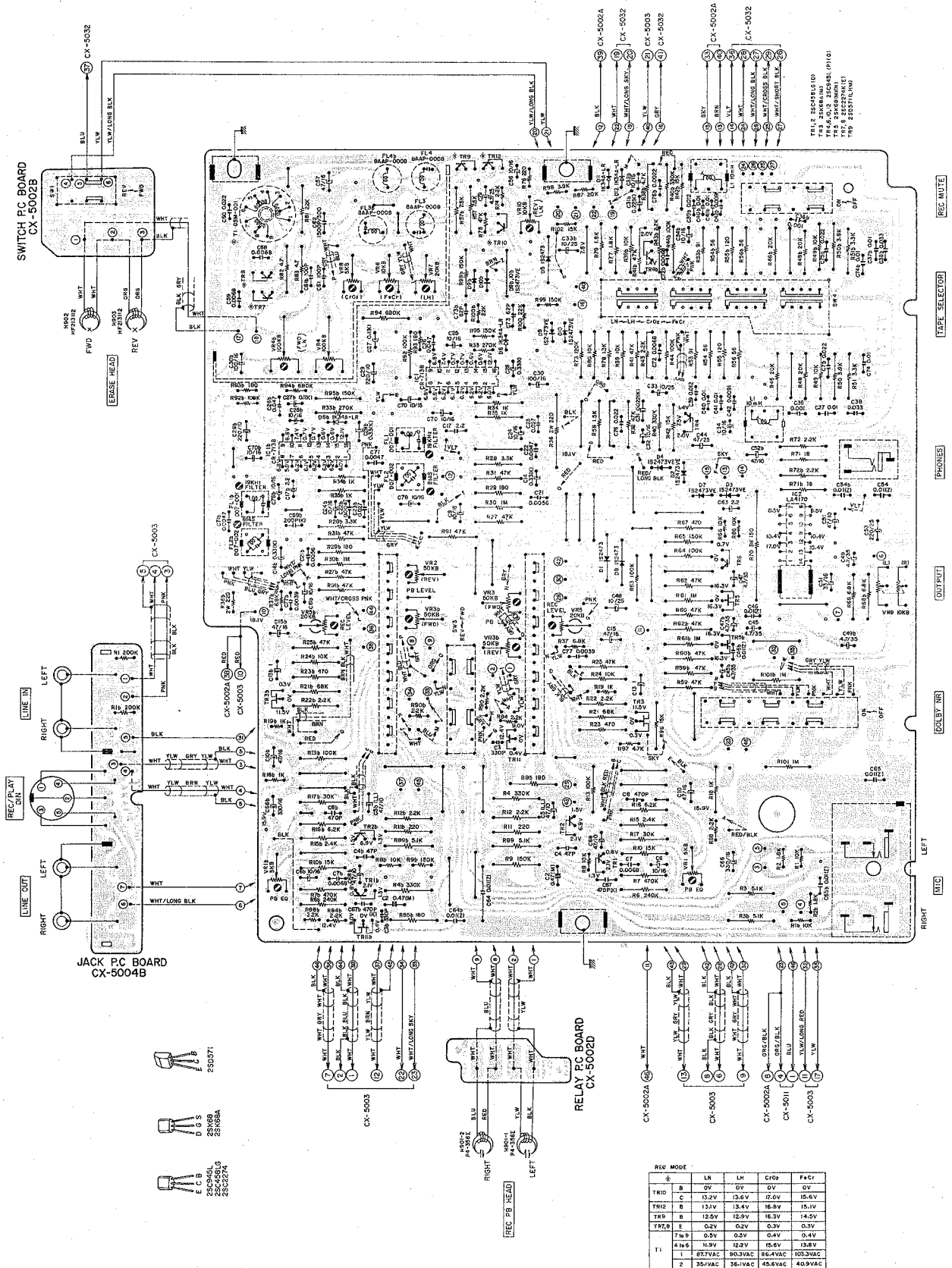

2) SYS. CON P.C BOARD CX-5032 & DIRECTION P.C BOARD CX-5011

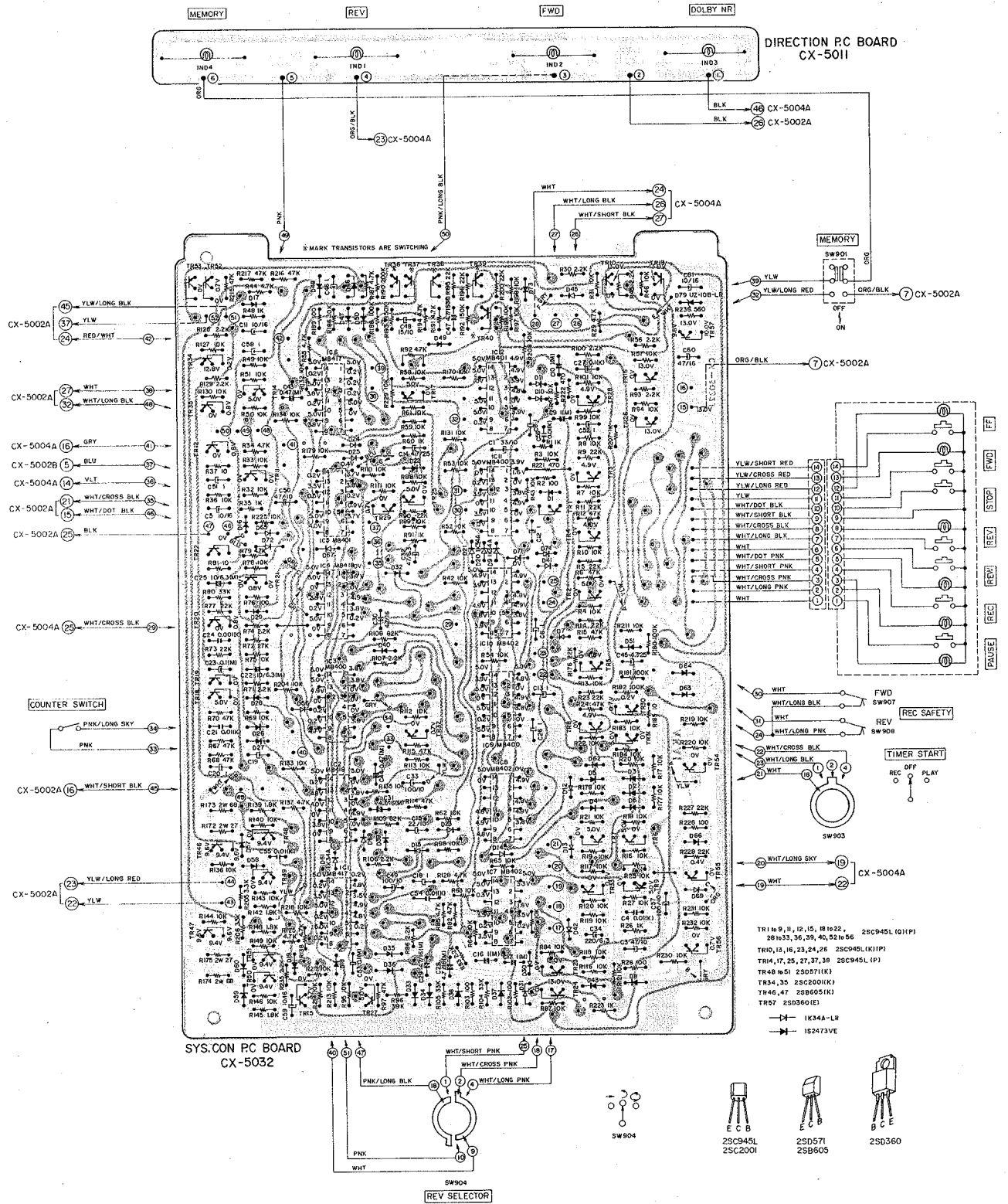

3) POWER SUPPLY P.C BOARD CX-5002A, METER LAMP P.C BOARD CX-5014,  
LAMP P.C BOARD CX-5002E & DETECTION P.C BOARD CY-0023

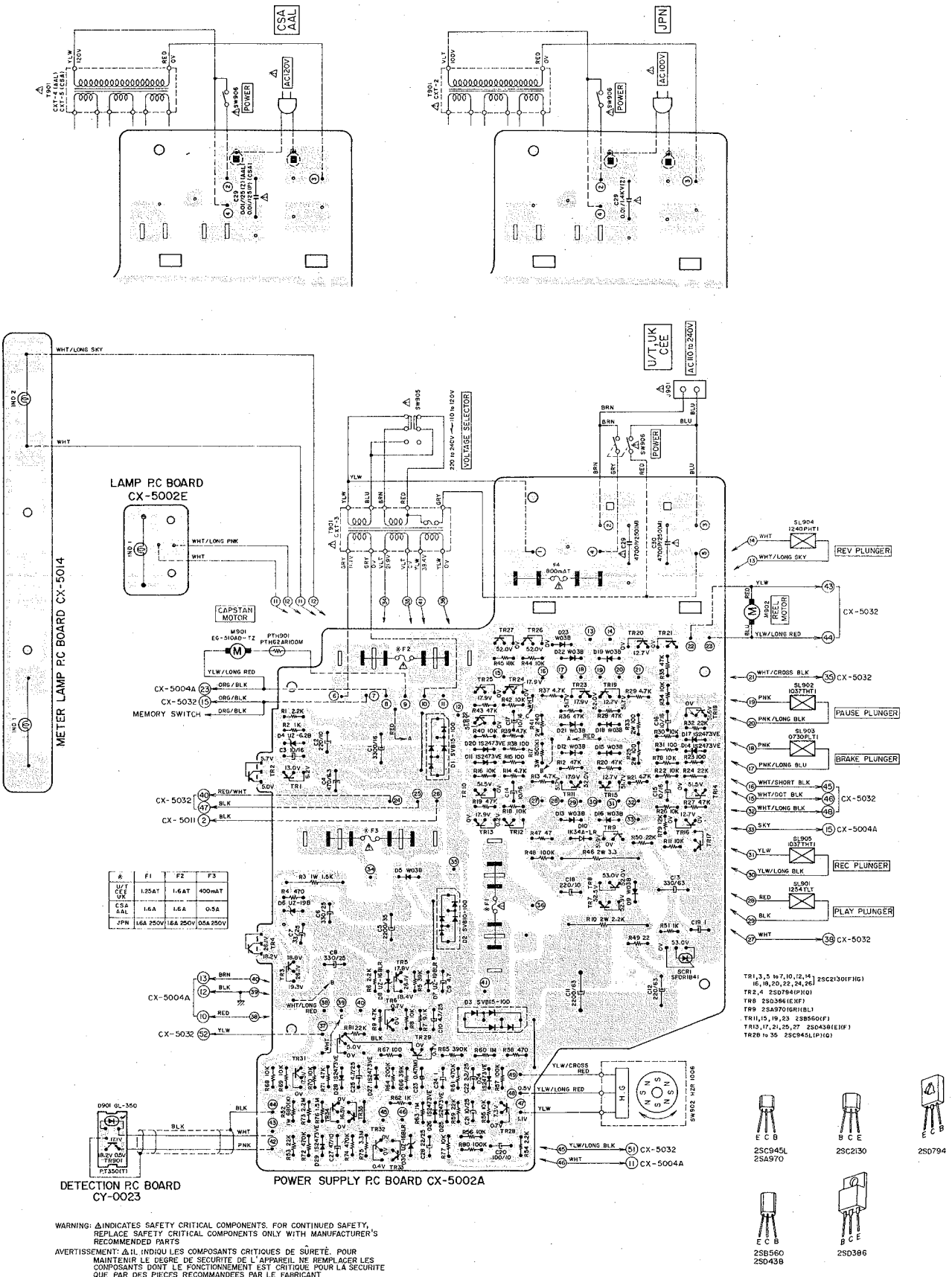

4) VOLUME P.C BOARD CX-5003 & PEAK P.C BOARD CX-5002C

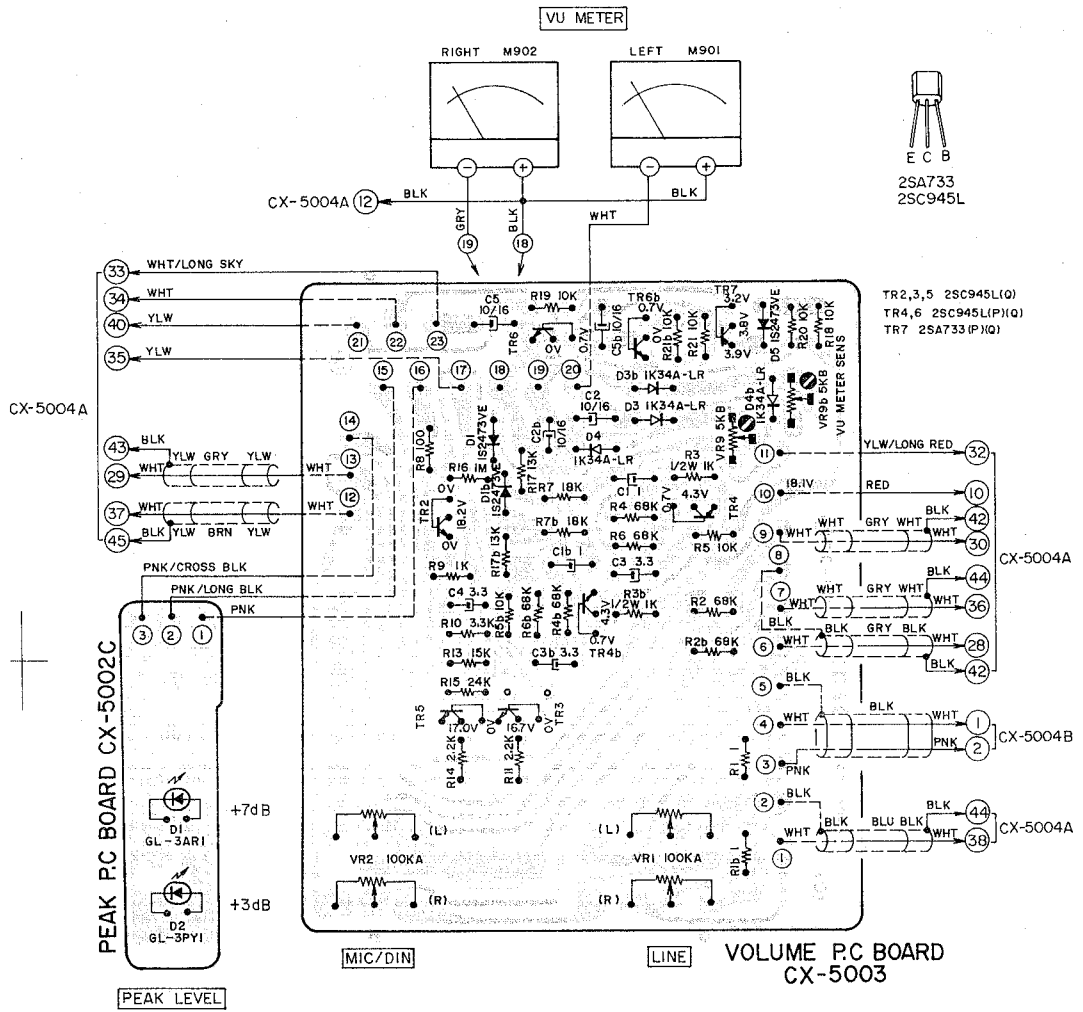

MEMO

---

---

SECTION 2

**PARTS LIST**

TABLE OF CONTENTS

1. RECOMMENDED SPARE PARTS LIST .....	44
2. HEAD BASE BLOCK .....	46
3. SUB FRAME BLOCK .....	47
4. CAPSTAN MOTOR BLOCK .....	48
5. CASSETTE BASE BLOCK .....	49
6. MECHA FRAME BLOCK (1) .....	50
7. MECHA FRAME BLOCK (2) .....	52
8. PRE AMP P.C BOARD (CX-5004A) BLOCK .....	53
9. SYS. CON P.C BOARD (CX-5032) BLOCK .....	54
10. POWER SUPPLY P.C BOARD (CX-5002A) BLOCK .....	55
11. VOL. P.C BOARD (CX-5003) BLOCK .....	55
12. ASSEMBLY BLOCK .....	56
13. FINAL ASSEMBLY BLOCK .....	58
14. LIST OF INTERCHANGEABLE SEMICONDUCTORS .....	59
INDEX .....	60

Resistor and Capacitor which is not listed in this parts list, please refer to COMMON LIST FOR SERVICE PARTS.



## HOW TO USE THIS PARTS LIST

1. This parts list is compiled by various individual blocks based on assembly process.
2. When ordering parts, please describe parts number, serial number, and model number in detail.
3. How to read List

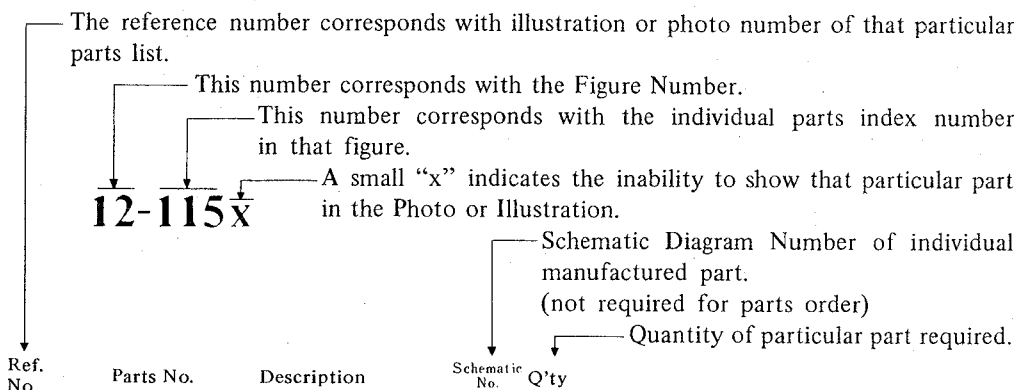

4. The symbol numbers shown on the P.C. Board list can be matched with the Composite Views of Components of the Schematic Diagram or Service Manual.
5. Please utilize separate "Common List for Service Parts" for Resistor Parts orders.
6. The shape of the parts and parts name, etc. can be confirmed by comparing them with the parts shown on the Electrical Parts Table of P.C. Board.
7. Both the kind of part and installation position can be determined by the Parts Number. To determine where a parts number is listed, utilize Parts Index at end of Parts List.  
It is necessary first of all to find the Parts Number. This can be accomplished by using the Reference Number listed at right of parts number in the Parts Index. (meaning of ref. no. outlined in Item 3 above).
8. Utilize separate "Price List for Parts" to determine unit price. The most simple method of finding parts Price is to utilize the reference number.

- CAUTION:**
1. When placing an order for parts, be sure to list the parts no. model no., and description. There are instances in which if any of this information is omitted, parts cannot be shipped or the wrong parts will be delivered.
  2. Please be careful not to make a mistake in the parts no. If the parts no. is in error, a part different from the one ordered may be delivered.
  3. Because parts number and parts unit supply in the Preliminary Service Manual (Basic Parts List) may be partially changed, please use this parts list for all future reference.

**WARNING:**  $\triangle$  INDICATES SAFETY CRITICAL COMPONENTS. FOR CONTINUED SAFETY, REPLACE SAFETY CRITICAL COMPONENTS ONLY WITH MANUFACTURER'S RECOMMENDED PARTS.

**AVERTISSEMENT:**  $\triangle$  IL INDIQU LES COMPOSANTS CRITIQUES DE SURETE. POUR MAINTENIR LE DEGRE DE SECURITE DE L'APPAREIL NE REMPLACER LES COMPOSANTS DONT LE FONCTIONNEMENT EST CRITIQUE POUR LA SECURITE QUE PAR DES PIECES RECOMMANDEES PAR LE FABRICANT.

## AC INLET SYSTEM

This model is equipped with an AC INLET SYSTEM. Please refer to the AC INLET SYSTEM CHART below for the specific type. By the AC INLET SYSTEM, AC (mains) cord can be connected to and disconnected from the model because the model is provided with socket exclusively for AC (mains) cord on its main body. Please note, however, that certain models are not equipped with this system and has a built-in AC (mains) cord as before.

### AC INLET SYSTEM CHART

#### CLASS I

#### CLASS II

☐ This mark indicating double insulation will be attached to machine's rear panel

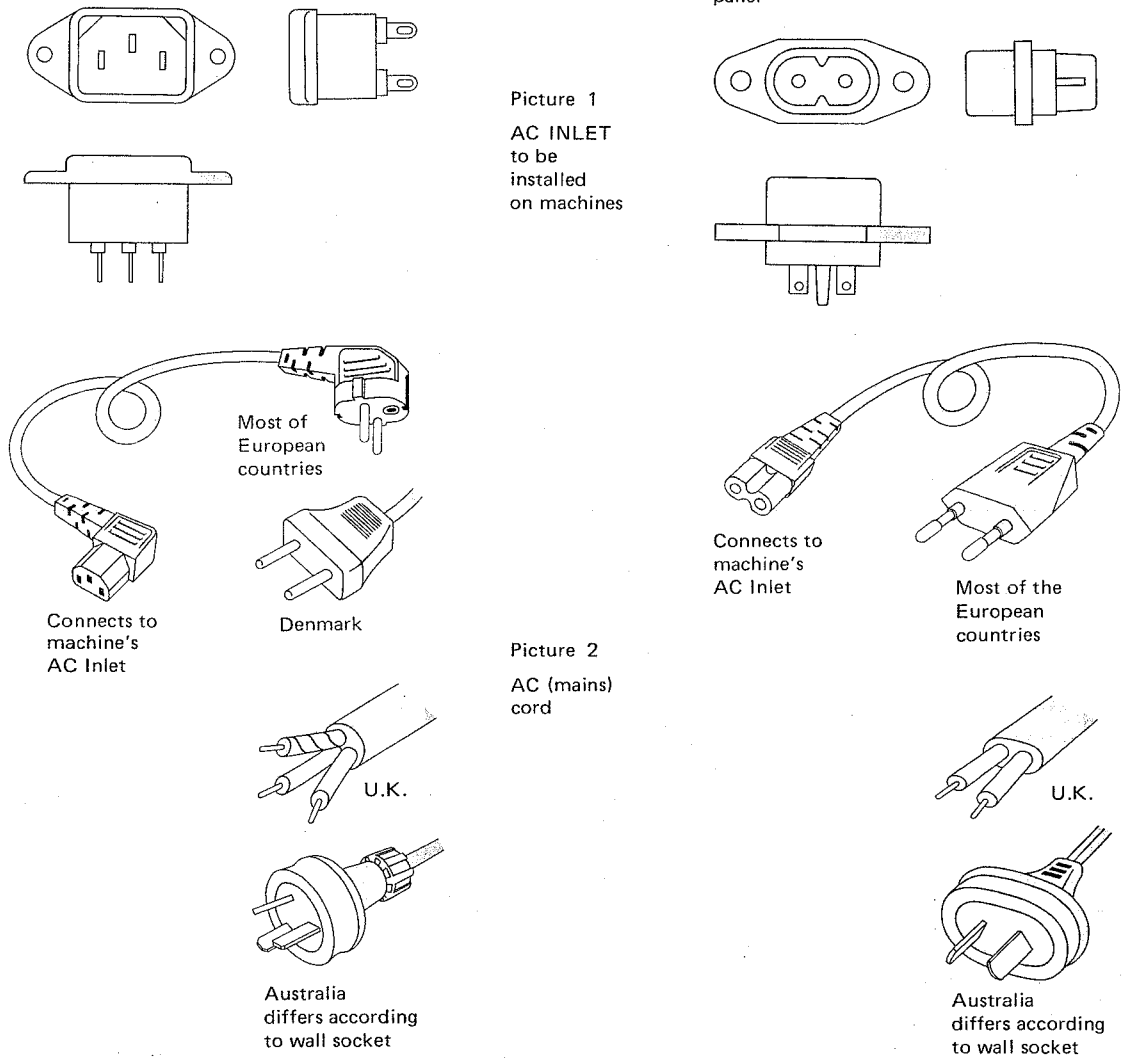

#### Parts List for AC (mains) Cord Set

Standard		Description	Type of AC Inlet	Parts No.
Class I	CEE	Cord Set CEE (3 cores)	3P	EW302993
	BEAB	Cord Set BEAB (3 cores)	3P	EW302994
	SAA	Cord Set SAA (3 cores)	3P	EW302996
	U/T	Cord Set U/T (3 cores)	3P	EW302646
Class II	CEE	Cord Set CEE (2 cores)	2P	EW638144
	BEAB	Cord Set BEAB (2 cores)	2P	EW302995
	SAA	Cord Set SAA (2 cores)	2P	EW302991
	U/T	Cord Set U/T (2 cores)	2P	EW302899

## 1. RECOMMENDED SPARE PARTS LIST

Because, if the parts listed below are on hand, almost any repair can be accomplished, we suggest that you stock these Recommended Spare Parts Items.

Parts No.	Description	Note
BA311463	Power Supply P.C Board Comp. GXC-735D (AAL)	
BA311462	Power Supply P.C Board Comp. GXC-735D (CSA)	
BA311461	Power Supply P.C Board Comp. GXC-735D (JPN)	
BA311460	Power Supply P.C Board Comp. GXC-735D (U/T)	
BA311483	Pre Amp. P.C Board Comp. GXC-735D	
BA314296	Sys. Con. P.C Board Comp. GXC-735D	
BA311478	Vol. P.C Board Comp. GXC-735D	
BF314499	Flywheel (A-2) Part GXC-735D	
BF313347	Flywheel Part GXC-735D	
BH308338	Head Base Block Comp. GXC-735D	
BK312300	Operation SW. Block Comp. GXC-735D	
BK313305	Operation SW. Block Comp. GXC-735D-BL	
BL312508	Pinch Roller Arm (L) Part GXC-735D	
BL312509	Pinch Roller Arm (R) Part GXC-735D	
BL313549	Pinch Roller Part CS-732D	
BM312302	Capstan Motor Block Comp. GXC-735D	
BM312289	Reel Motor Block Comp. GXC-735D	
BT313507	△ Power Trans. CXT-2	(JPN)
BT313508	△ Power Trans. CXT-3	(U/T, CEE, UK)
BT313509	△ Power Trans. CXT-4	(AAL)
BT313510	△ Power Trans. XCT-5	(CSA)
BZ312296	Cassette Base Block Comp. GXC-735D	
BZ311452	Detection Tape Guide Block Comp. CS-732D	
EC551160	△ Ceramic/C. DB821 NA 0.01μF (Z) 1.4kVW	
EC294118	△ Ceramic/C. DPN6600 YM 0.01μF (P) 125WV	
EC305737	△ Ceramic/C. LB832 Z 0.01μF (Z) 125WV	
EC301320	△ MP/C. 4700PF (M) 250WV	
EC301320	△ MP/C. 4700PF (M) 250WV	
ED309341	Germanium Diode 1K34A	
ED308952	Germanium Diode 1K34A-LR	
ED308952	Germanium Diode 1K34A-LR	
ED249377	LED GL-3AR1	
ED303005	LED GL-3PY1	
ED308945	Silicon Diode SVB10-100	
ED309357	Silicon Diode SVB15-100	
ED306109	Silicon Diode W03B	
ED624903	Silicon Diode 1S2473	
ED560913	Silicon Diode 1S2473 VE	
ED560913	Silicon Diode 1S2473 VE	
ED650968	Thermister (Sine) PTH62AR 100M	
ED313513	Thyristor SF0R1B41	
ED315354	Zener Diode UZ-19B	
ED314698	Zener Diode UZ-6.2B	
ED313730	Zener Diode (Vert.) UZ-168LR	
ED310541	Zener Diode (Vert.) UZ-198LR	
EF313489	△ Fuse ST-6 0.5A	(CSA, AAL)
EF659711	△ Fuse ST-6 1.6A	(CSA, AAL)
EF563670	△ Fuse 0.5A 250V	(JPN)
EF616555	△ Fuse 1.6A 250V	(JPN)
EF602550	△ Fuse (SEMKO T Type) 1.25AT 250V	(U/T, CEE, UK)
EF601964	△ Fuse (SEMKO T Type) 1.6AT	(U/T, CEE, UK)
EF668474	△ Fuse (SEMKO T Type) 400MAT	(U/T, CEE, UK)
EF258344	△ Fuse (SEMKO T Type) 800MAT	(U/T, CEE, UK)
EI304165	IC MB400M	
EI313694	IC MB401	
EI305237	IC MB402	
EI305238	IC MB417M	
EI304166	IC MB418	

Parts No.	Description	Note
EI301463	IC CR-713B	
EI306141	IC LA4170	
EM313546	VU Meter D60A0R	
EM313546	VU Meter D60A0R	
EP313497	Plunger 0730THT	
EP313498	Plunger 1037THTI	
EP313498	Plunger 1037THTI	
EP313511	Plunger 1254THT	
ES309058	△ Push SW. JP-24	(U/T, CEE, UK)
ES309059	△ Push SW. JP-27	(JPN)
ES313492	Leaf SW. BSW-31CB	
ES313493	Leaf SW. BSW-31CC	
ES313496	Push SW. SPJ222A	
ES313537	Push SW. SUF12	
ES313539	Push SW. SUF12	
ES302508	Revolution SW. HRZ1006	
ES313735	Rotary Slide SW. SRZ-V084S	
ES313734	Rotary SW. SRN1023S	
ES313732	Slide SW. CL107K	
ES313500	Slide SW. CL202E	
ES310827	Slide SW. CL204E	
ES309312	Slide SW. 22293B	
ET301464	FET 2SK68 (M) (N)	
ET313717	FET 2SK68A (M)	
ET302466	FET 2SK68A (Special)	
ET554657	Transistor 2SA733 (P) (Q)	
ET305463	Transistor 2SA970 (GR) (BL)	
ET313728	Transistor 2SB560 (F)	
ET313525	Transistor 2SB605 (K)	
ET302502	Transistor 2SC2001 (K)	
ET311868	Transistor 2SC2130 (F) (G)	
ET310833	Transistor 2SC2274K(E)	
ET352146	Transistor 2SC458LG (D)	
ET635220	Transistor 2SC945L (K) (P)	
ET638504	Transistor 2SC945L (P)	
ET399846	Transistor 2SC945L (Q)	
ET639437	Transistor 2SC945L (Q) (P)	
ET292375	Transistor 2SD360 (E)	
ET313514	Transistor 2SD386 (E) (F)	
ET219857	Transistor 2SD438 (E) (F)	
ET208012	Transistor 2SD571 (K)	
ET655356	Transistor 2SD571 (L) (M)	
ET307349	Transistor 2SD794 (P) (Q)	
EW306427	△ AC Cord (JPN)	
EW305691	△ AC Cord CUL	(CSA, AAL)
EW306152	△ AC Cord Set U/T Type 2	(JPN, CSA, AAL)
EZ631945	△ Strain Relief SR-4N-4	
HE314574	Erase Head HF213112	
HP312298	Head P4-356Σ	
MB313387	Capstan Belt	
MB313388	Counter Belt	
MB313389	Revolution SW. Belt	
MC313495	Counter Part SMP390-183	
MC313494	Counter Part SMP390-183-BL	
MC-314712	Counter Part SMP390-183B	(JPN)
MI309414	Idler Part	
MT305793	Reel Cap	
MT312122	Reel Table Part GXC-715D	
MV309146	Main Case	
TC311515	Damper Part GXC-735D	

## 2. ILLUSTRATION OF HEAD BASE BLOCK

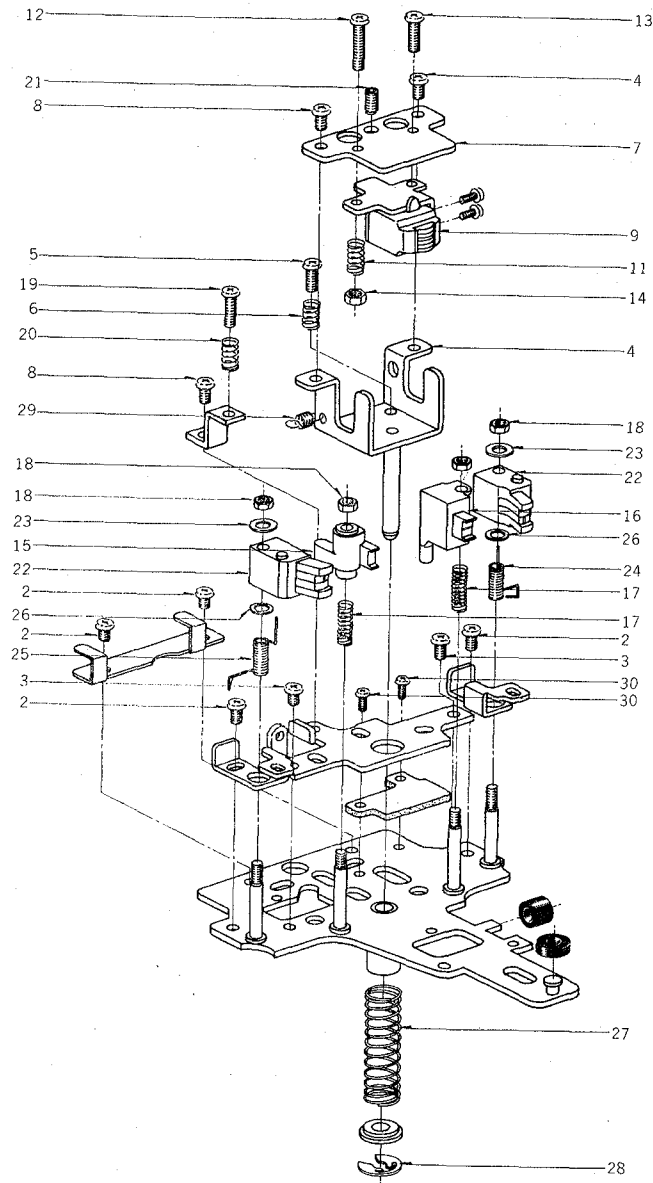

## 2. HEAD BASE BLOCK

Ref. No.	Parts No.	Description	Schematic No.	Ref. No.	Parts No.	Description	Schematic No.
2-1	BF308338	Head Base Block Comp. GXC-735D		2-16	BZ311452	Detection Tape Guide Block Comp. CS-732D	
2-2	ZS592378	Screw, pan 2.6x3		2-17	ZG313314	Adjust Spring	CY-0024
2-3	ZS608174	Screw, pan 2.6x3		2-18	ZW273734	Nut #1 M2	CX-0015
2-4	ML311537	Shift Base Part GXC-7350	CX-0008	2-19	ZS391522	Screw, pan 2.3x8	
2-5	ZS590804	Screw, pan 2.3x6		2-20	ZG369088	Angle Adjust Spring	RCC-1032
2-6	ZG369088	Angle Adjust Spring	RCC-1032	2-21	ZS433001	Set Screw, hexagon socket 3x5 (Cup/P.)	
2-7	HZ313309	Head Hanger	CX-0011	2-22	HE314574	Erase Head HF213112	37-2-22
2-8	ZS375107	Screw, pan 2.6x4		2-23	ZW259650	Washer (PBP) D3x5x0.2t	
2-9	HP312298	Head P4-356Σ		2-24	ZG313316	Erase Head Spring	CX-0018
2-10	ZS201508	Screw, pan 2x4		2-25	ZG313874	Erase Head Spring (B)	CX-0018
2-11	ZG465636	Angle Adjust Spring	CG-0029	2-26	ZW300888	Washer D2.3x6x0.4t	
2-12	ZS391408	Screw, pan 2.3x12		2-27	ZG313691	Clamp Spring	CX-0017
2-13	ZS391522	Screw, pan 2.3x8		2-28	ZW290283	'U' Ring 2.85M	6-1-1
2-14	ZW313501	Nut #2 M2.3		2-29	ZG576314	FF Idler Spring	PW-2030
2-15	HZ313313	Tape Guide	CX-0014	2-30	ZS460440	Screw, pan 2x4	

When ordering parts, please describe Parts Number, Description, and Model Number in detail.

### 3. ILLUSTRATION OF SUB FRAME BLOCK

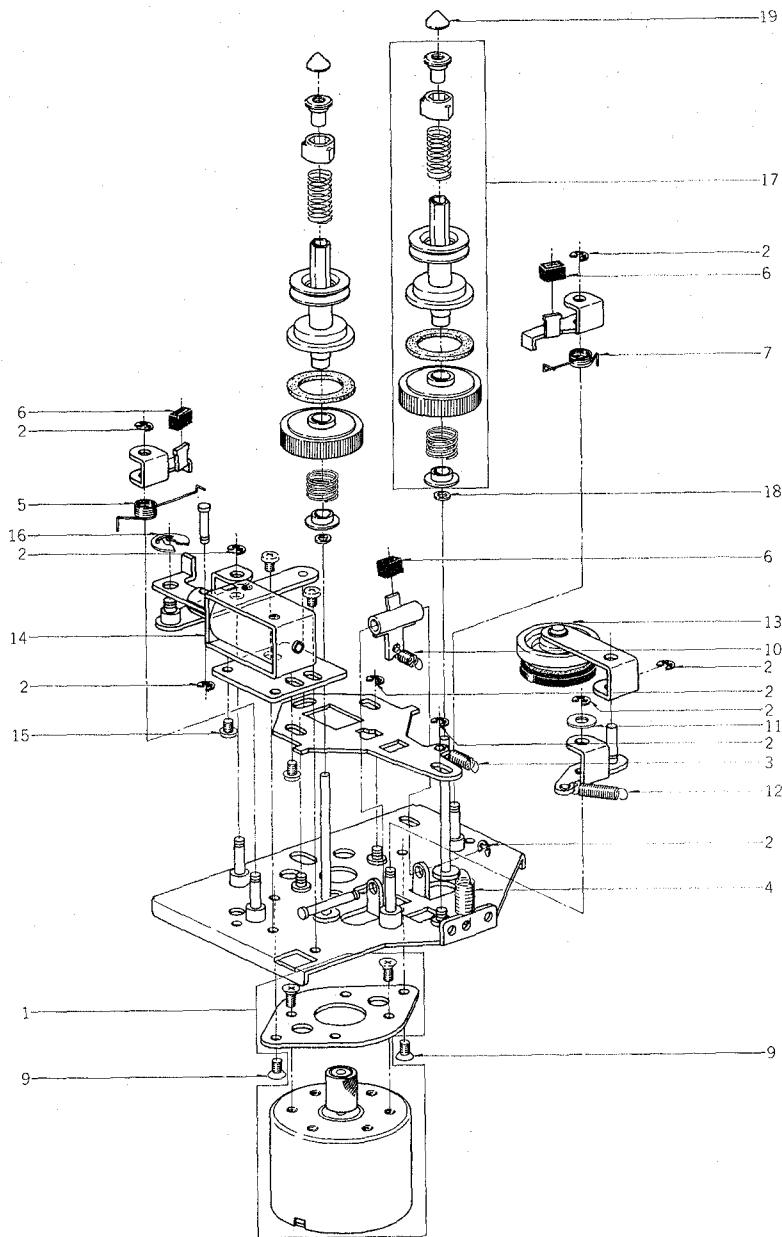

### 3. SUB FRAME BLOCK

Ref. No.	Parts No.	Description	Schematic No.	Ref. No.	Parts No.	Description	Schematic No.
<b>REEL MOTOR BLOCK</b>							
3-1	BM312289	Reel motor Block Comp. GXC-735D		3-9	ZS430413	Screw, countersunk 2.6x4	
<b>SUB FRAME BLOCK</b>							
3-2	ZW270088	'E' Ring 1.9M	6-1-9	3-10	ZG469315	Take-up Lever Spring	CG-1091
3-3	ZG525993	SW. Return Spring	CV-2060	3-11	ZW432753	Washer (PBP) D3.1x8x0.2t	
3-4	ZG313392	Head Return Spring	CX-1064	3-12	ZG315481	Idler Spring	CX-1099
3-5	ZG309225	Brake Spring (L)	CF-2022	3-13	MI309414	Idler Part	13-2-42
3-6	MB282104	Brake Rubber	CN-1020	3-14	EP313497	Plunger 0730THT	44-1-108
3-7	ZG309226	Brake Spring (R)	CF-2023	3-15	ZS592378	Screw, pan 2.6x3	
3-8x	ZS313823	S-tight Screw, pan 3x4		3-16	ZW290283	'U' Ring 2.85M	6-1-1
				3-17	MT312122	Reel Table Part GXC-715D	13-2-41
				3-18	ZW474581	Washer (Teflon) D2.05x3.5x0.2t	
				3-19	MT305793	Reel Cap	CF-2039

When ordering parts, please describe Parts Number, Description, and Model Number in detail.

#### 4. ILLUSTRATION OF CAPSTAN MOTOR BLOCK

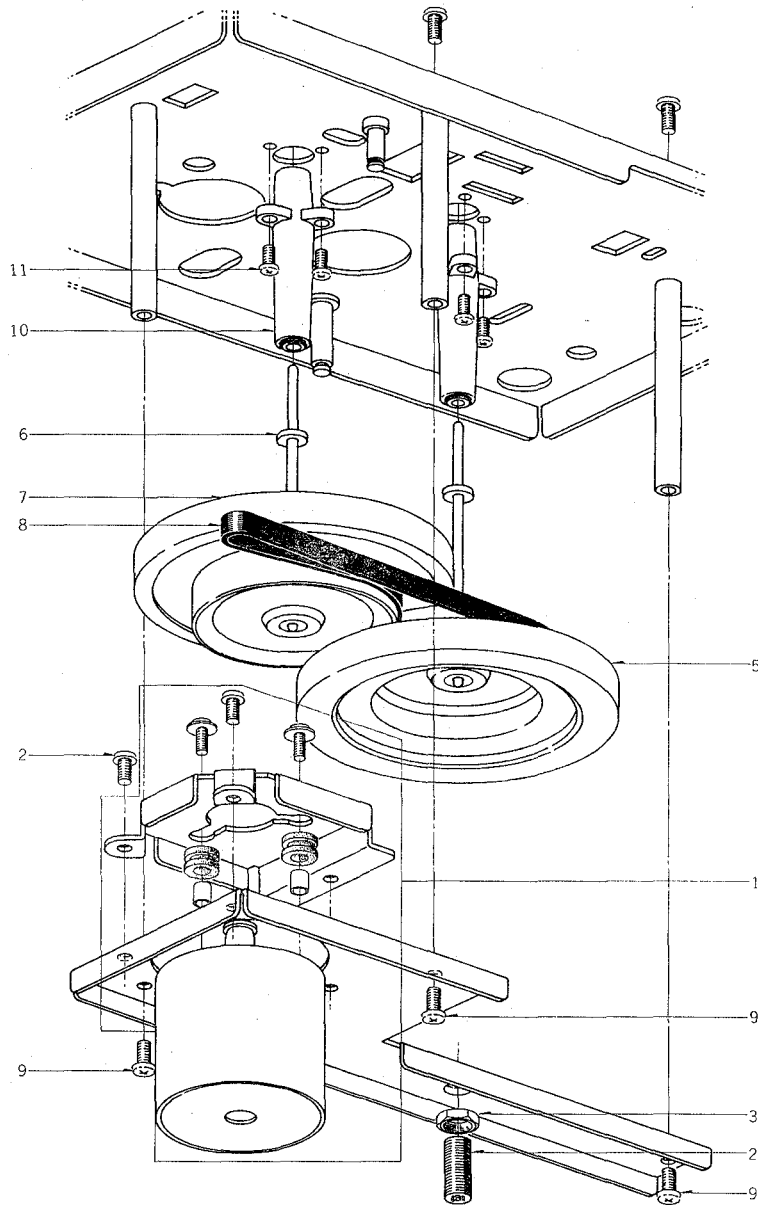

#### 4. CAPSTAN MOTOR BLOCK

Ref. No.	Parts No.	Description	Schematic No.
<b>CAPSTAN MOTOR BLOCK</b>			
4-1	BM312302	Capstan Motor Block Comp. GXC-735D	
4-2	ZS302318	Holder Screw	CF-1258
4-3	ZW303680	Metal Nut	CF-1273
4-4	ZS422076	Screw, pan 3x5	
<b>MECHA FRAME BLOCK</b>			
4-5	BF314499	Flywheel (A-2) Part GXC-735D	CF-1050
4-6	ZW313419	Thrust Washer	CX-1092
4-7	BF313347	Flywheel Part GXC-735D	CX-1021
4-8	MB313387	Capstan Belt	CX-1060
4-9	ZS379350	Screw, pan 3x6	
4-10	MV309146	Main Case	CY-1042
4-11	ZS479474	Screw, pan 2.6x5	

When ordering parts, please describe Parts Number, Description, and Model Number in detail.

## 5. ILLUSTRATION OF CASSETTE BASE BLOCK

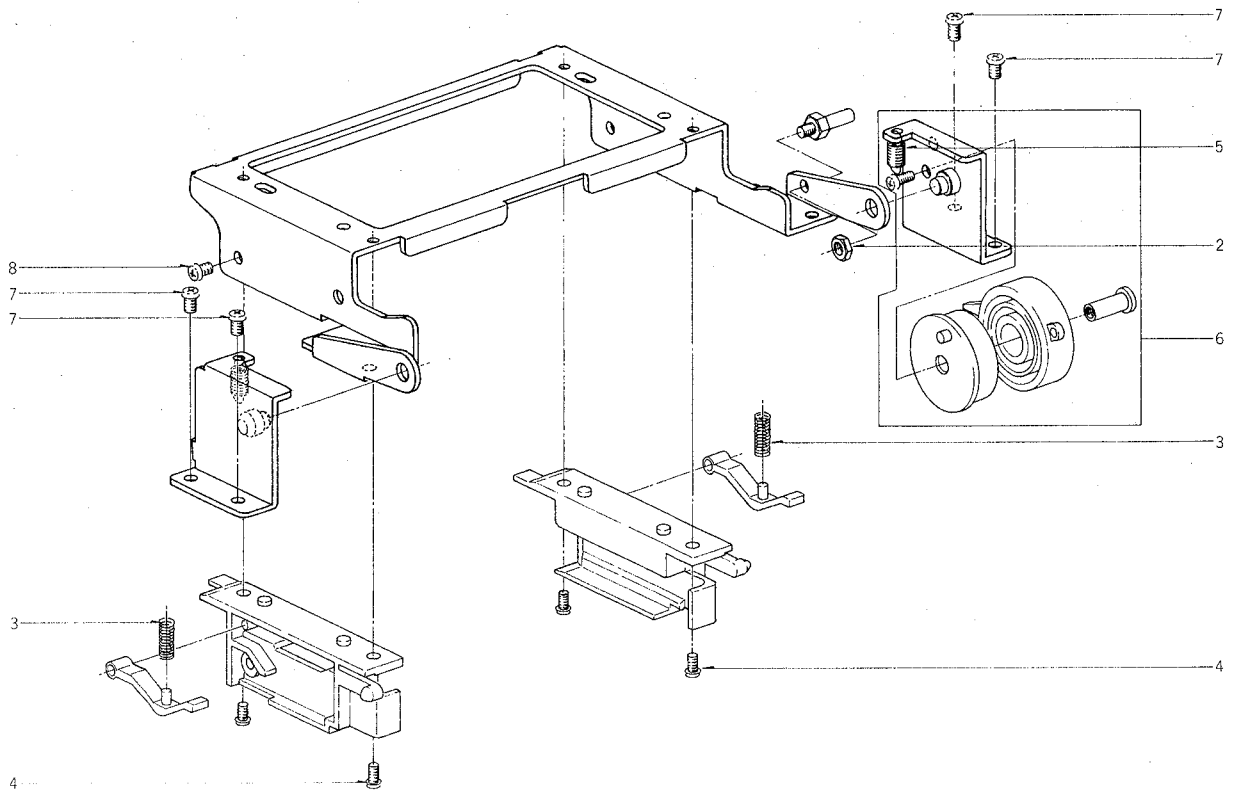

## 5. CASSETTE BASE BLOCK

Ref. No.	Parts No.	Description	Schematic No.
<b>CASSETTE BASE BLOCK</b>			
5-1	BZ312296	Cassette Base Block Comp. GXC-735D	
5-2	ZW516611	Nut M3	
5-3	ZG313423	Setting Spring	CX-1097
5-4	ZS375107	Screw, pan 2.6x4	
5-5	ZG313376	Eject Spring	CX-1050
<b>MECHA FRAME BLOCK</b>			
5-6	TC311515	Damper Part GXC-735D	CX-1093
5-7	ZS417216	Screw, pan 3x4	
5-8	ZS608477	Screw, pan 3x4	



## 6. ILLUSTRATION OF MECHA FRAME BLOCK (1)

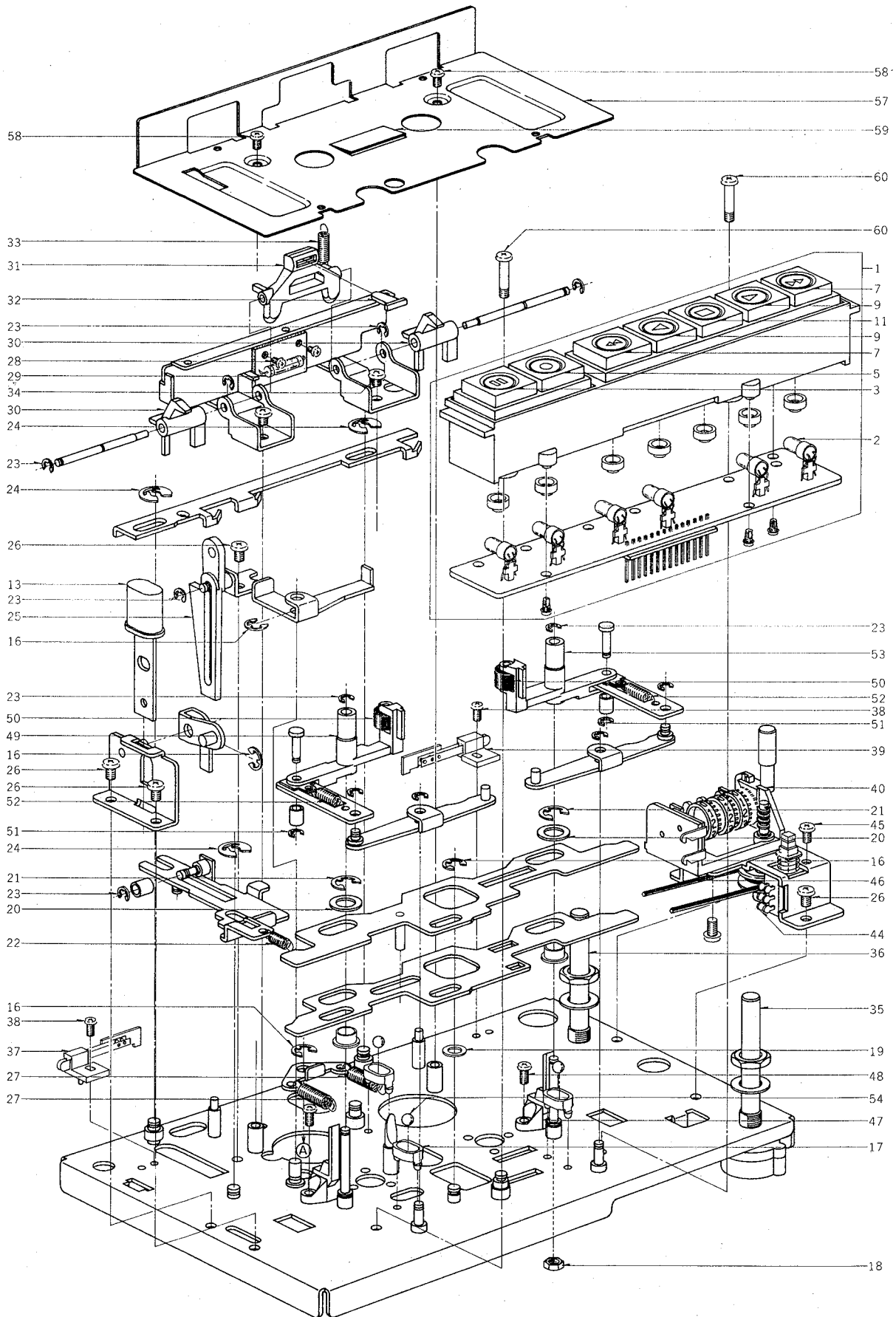

## 6. MECHA FRAME BLOCK (1)

Ref. No.	Parts No.	Description	Schematic No.
<b>OPERATION SW. BLOCK</b>			
6-1	BK312300	Operation SW. Block Comp. GXC-735D	25-5-294
6-2	EL313726	Lamp 16V 40mA	25-5-294
6-3	SB313721	Operate Button (Pause)	25-5-294
6-4x	SB313786	Operation Button (Pause) (BL)	25-5-316
6-5	SB313722	Operate Button (REC)	25-5-294
6-6x	SB313784	Operate Button (REC) (BL)	25-5-316
6-7	SB313723	Operate Button (FF, REW)	25-5-294
6-8x	SB313785	Operate Button (FF, REW) (BL)	25-5-316
6-9	SB313724	Operate Button (FWD, REV)	25-5-294
6-10x	SB313782	Operate Button (FWD, REV) (BL)	25-5-316
6-11	SB313725	Operate Button (Stop)	25-5-294
6-12x	SB313783	Operate Button (Stop) (BL)	25-5-316
<b>EJECT KEY BLOCK</b>			
6-13	SK305674	Power SW. Cap	CN-6338
6-14x	SK314618	Power SW. Cap (B) (JPN)	CN-6338
6-15x	SK306130	Power SW. Cap (BL)	CN-6338
6-16	ZW270101	'E' Ring 3M	6-1-9
<b>MECHA FRAME BLOCK</b>			
6-17	MS302191	Ball Guide	CI-1209
6-18	ZW516993	Nut M3, #1	
6-19	ZW259773	Washer (Nylon) D4.1x7x0.5t	
6-20	ZW560215	Washer (Teflon) D6.1x10x0.5t	
6-21	ZW270123	'E' Ring 4M	6-1-9
6-22	ZG312996	Coil Spring T1 4.0/0.4-14.0	
6-23	ZW270088	'E' Ring 1.9M	6-1-9
6-24	ZW290283	'U' Ring 2.85M	6-1-1
6-25	MZ313379	Eject Stopper	CX-1053
6-26	ZS417216	Screw, pan 3x4	
6-27	ZG313390	P Spring	CX-1063
6-28	ZS477876	Screw, pan 2x3	
6-29	EL313491	Lamp (Lead type) 15V 100mA	28-2-73
6-30	ML313383	REC Safety Lever	CX-1056
6-31	TC309154	Cassette Folder	CF-1023
6-32	TC315597	Friction Rubber	CX-1102
6-33	ZG313386	Cassette Folder Spring	CX-1059
6-34	ZS432674	Screw, pan 3x3	
6-35	ES309397	Rotary SW. SRN1013S	25-6-120
6-36	ES313734	Rotary SW. SRN1023S	25-6-171
6-37	ES313492	Leaf SW. BSW-31CB	25-10-33
6-38	ZS355544	Screw, bind 2x4	
6-39	ES313493	Leaf SW. BSW-31CC	25-10-34
6-40	MC313495	Counter Part SMP390-183	9-1-62
6-41x	MC314712	Counter Part SMP390-183B (JPN)	9-1-70
6-42x	MC313494	Counter Part SMP390-183-BL	9-1-63
6-43	ZS422076	Screw, pan 3x5	
6-44	ES313496	Push SW. SPJ222A	25-5-293
6-45	ZS432843	Screw, pan 2.6x4	
6-46	MB313388	Counter Belt	CX-1061
6-47	TC309145	Cassette Guide	CF-1015
6-48	ZS479474	Screw, pan 2.6x5	
6-49	BL312508	Pinch Roller Arm (L) Part GXC-735D	
6-50	BL313549	Pinch Roller Part CS-732D	CY-1017
6-51	ZW356657	'E' Ring 1.5M	6-1-9
6-52	ZG313361	Pinch Roller Spring	CX-1036
6-53	BL312509	Pinch Roller Arm (R) Part GXC-735D	
6-54	MV269965	Steel Ball D4	
6-55x	ZW315745	Washer D5.1x7.8x0.4t	
6-56x	ZW316635	Washer D5.1x7.8x0.35t	
6-57	SZ313412	Decoration Plate	CX-1085
6-58	ZS267254	Screw, pan 2.3x4 (Black)	
6-59	TC645186	Reflector	CA-2071
6-60	ZS530684	Roller Screw B	91-5010
6-61x	BK313305	Operation SW. Block Comp. GXC-735D-BL	25-5-316

When ordering parts, please describe Parts Number, Description, and Model Number in detail.

## 7. ILLUSTRATION OF MECHA FRAME BLOCK (2)

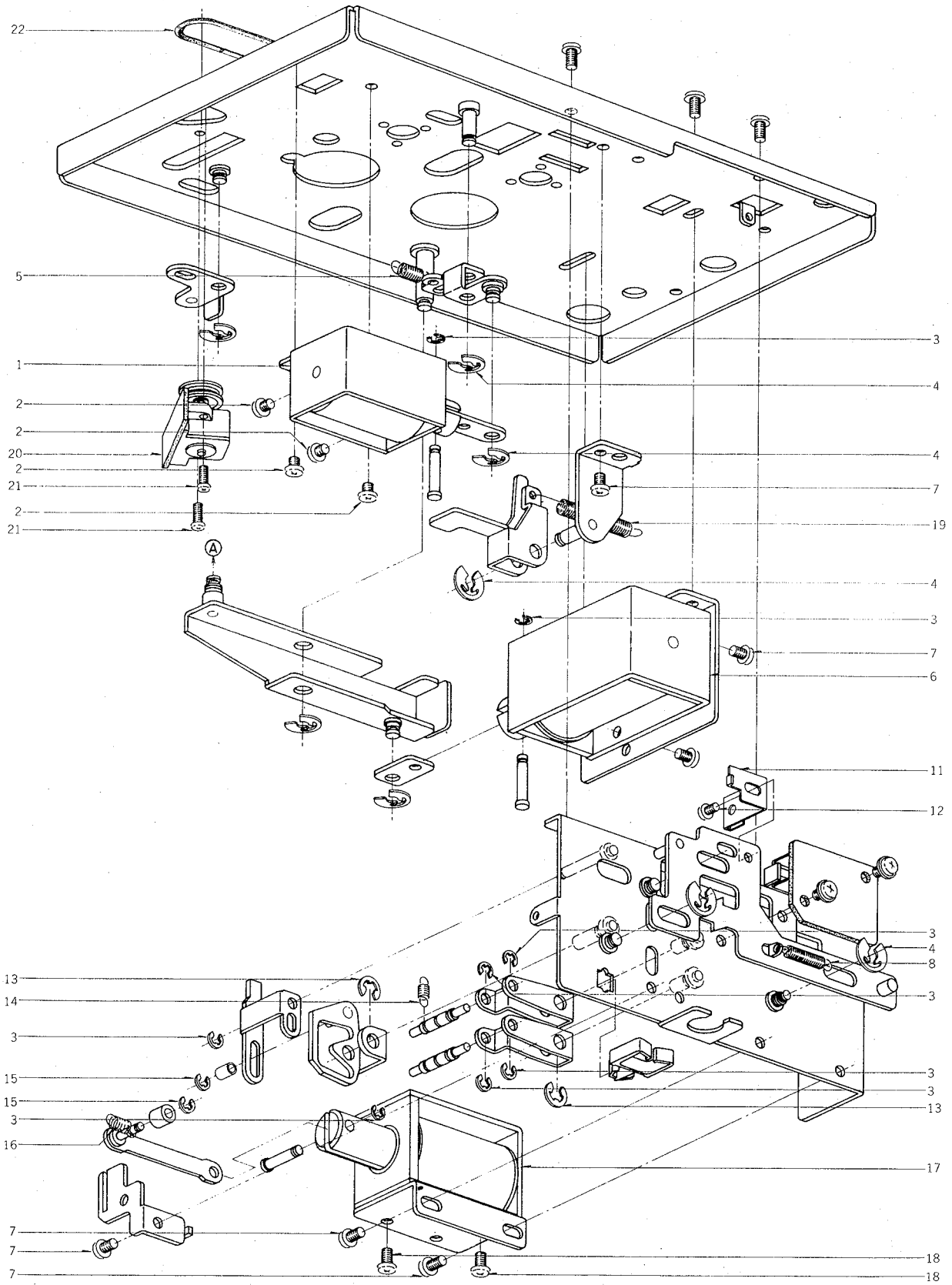

## 7. MECHA FRAME BLOCK (2)

Ref. No.	Parts No.	Description	Schematic No.
<b>PAUSE PLUNGER BLOCK</b>			
7-1	EP313498	Plunger 1037THTI	44-1-102
7-2	ZS432674	Screw pan 3x3	
7-3	ZW270088	'E' Ring 1.9M	6-1-9
7-4	ZW290283	'U' Ring 2.85M	6-1-1
7-5	ZG312996	Coil Spring T1-4.0/0.4-14.0	
<b>PLAY PLUNGER BLOCK</b>			
7-6	EP313511	Plunger 1254THT	44-1-101
7-7	ZS417216	Screw, pan 3x4	
<b>CHANGE BLOCK</b>			
7-8	ZG312948	Coil Spring T1-3.2/0.29-20.0	
7-9	ZS422076	Screw, pan 3x5	
7-10	ZS608275	Screw, pan 3x5, w/washer	
7-11	MZ313409	SW. Clutch	CX-1082
7-12	ZS592378	Screw, pan 2.6x3	
7-13	ZW270101	'E' Ring 3M	6-1-9
7-14	ZG580263	Lock Plate B Spring	IC-2016
7-15	ZW356657	'E' Ring 1.5M	C-1-9
7-16	ZG313407	Reverse Spring	CX-1080
7-17	EP313499	Plunger 1240PHTI	44-1-100
7-18	ZS323728	Screw, Bind 3x5	
<b>MECHA FRAME BLOCK</b>			
7-19	ZG313342	Shift Spring	CX-1017
7-20	ES302508	Revolution SW. FRZ1006	25-9-5
7-21	ZS608095	Screw, pan 2x5	
7-22	MB313389	Revolution SW. Beft	CX-1062

## 8. PRE AMP P.C BOARD (CX-5004A) BLOCK

Symbol No.	Parts No.	Description	Schematic No.
8-1	BA311483	Pre Amp P.C Board Comp. GXC-735D	CX-5004A
8-2	ZS417216	Screw, pan 3x4	
8-J1	EJ305739	MIC Jack JU2	31-2-89
8-J2	EJ305629	Headphone Jack JL3A	31-2-90
8-SW1	ES313732	Slide SW. CL107K	25-3-167
8-SW2	ES313539	Push SW. SUF12	25-5-292
8-SW3	ES310827	Slide SW. CL204E	25-3-153
8-SW4	ES313735	Rotary Slide SW. SRZ-V084S	25-6-170 25-5-291
8-SW5	ES313537	Push SW. SUF12	
8-VR1	EV305635	Semi-fixed/Vol. D8 Axial Type 5 kB	36-10-273
8-VR2,3	EV305636	Semi-fixed/Vol. D8 Axial Type 50 kB	36-10-273
8-VR4	EV305640	Semi-fixed/Vol. D10 Axial Type 100 kB	36-10-274
8-VR5	EV305639	Semi-fixed/Vol. D8 Axial Type 20 kB	36-10-273
8-VR6	EV305637	Semi-fixed/Vol. D8 Axial Type 10 kB	36-10-273
8-VR7	EV305639	Semi-fixed/Vol. D8 Axial Type 20 kB	36-10-273
8-VR8	EV305639	Semi-fixed/Vol. D8 Axial Type 5 kB	36-10-273
8-VR9	EV313538	Single Axial 2 Throw Vol. GM80R 10 kBx2	36-22-43
8-VR10	EV305637	Semi-fixed/Vol. D8 Axial Type 10 kB	36-10-273
8-11	EO310831	OSC Coil OSM-001	23-4-48
8-IC1	EI301463	IC CR-713B	45-8-225
8-IC2	EI306141	IC LA4170	45-8-305
8-TR1,2	ET352146	Transistor 2SC458LG(D)	45-1-29
8-TR3	ET313717	FET 2SK68A(M)	45-12-9
8-TR4	ET639437	Transistor 2SC945L(Q)(P)	45-1-85
8-TR5	ET301464	FET 2SK68(M)(N)	45-12-14
8-TR6	ET639437	Transistor 2SC945L(Q)(P)	45-1-85
8-TR7,8	ET310833	Transistor 2SC2274K(E)	45-1-335
8-TR9	ET655356	Transistor 2SD5711(L)(M)	45-1-218
8-TR10	ET639437	Transistor 2SC945L(Q)(P)	45-1-85
8-TR11	ET302466	FET 2SK68A (Special)	45-12-17
8-TR12	ET639437	Transistor 2SC945L(Q)(P)	45-1-85
8-D1	ED624903	Silicon Diode 1S2473	45-3-28
8-D2to4	ED560913	Silicon Diode 1S2473 VE	45-3-23
8-D5	ED624903	Silicon Diode 1S2473	45-3-28
8-D6	ED308952	Germanium Diode 1K34A-LR	45-3-47
8-D7	ED560913	Silicon Diode 1S2473 VE	45-3-23
8-D8	ED624903	Silicon Diode 1S2473	45-3-28
8-D9,10	ED560913	Silicon Diode 1S2473 VE	45-3-23
8-D11,12	ED308952	Germanium Diode 1K34A-LR	45-3-47
8-L1	EO262484	DM Coil 10MH	23-1-11
8-FL1	ER309119	Dolby Filter D07-001	53-1-143
8-FL2	ER309361	Dolby Filter D07-002	53-1-143
8-FL3,4	EO309363	Trap Coil 8AAP-0008	23-1-302
8-R36	ER313699	Metal Oxide Film/R. 2W 220 ohms (J)	35-11-19
8-R70	ER313853	Metal Oxide Film/R. 3W 150 ohms (J)	35-11-20
8-C2	EC314986	NP/C. (LR, Vert.) 0.47μF (M) 50 WV	24-17-34
8-C3	EC513990	Styrol/C. (Vert.) 330PF (J) 50WV	24-11-3
8-C8	EC405898	Styrol/C. (Vert.) 470PF (J) 50WV	24-11-3
8-C62	EC308965	Styrol/C. 1500PF (J) 500WV	24-11-16
8-C67	EC516767	Styrol/C. (Vert.) 470PF (K) 50WV	24-11-3
8-C69(L)	EC305677	Styrol/C. 200PF (K) 50WV	24-11-14
8-C69(R)	EC516701	Styrol/C. (Vert.) 200PF (K) 50WV	24-11-3

When ordering parts, please describe Parts Number, Description, and Model Number in detail.

## 9. SYS CON P.C BOARD (CX-5032) BLOCK

Symbol No.	Parts No.	Description	Schematic No.	Symbol No.	Parts No.	Description	Schematic No.
9-1	BA314296	Sys. Con P.C Board Comp. GXC-735D	CX-5032	9-D74	ED308952	Germanium Diode 1K34A-LR	45-3-47
9-J902	EJ304317	Mini. Connection 3021-14	31-1-176	9-D79	ED315221	Zener Diode (Vert.) UZ-10BLR	45-6-85
9-IC1	EI305238	IC MB417M	45-8-255	9-R172	ER313528	Metal Oxide Film/R. 2W 27 ohms (J)	35-11-19
9-IC2	EI304166	IC MB418	45-8-253	9-R173,174	ER315355	Metal Oxide Film/R. 2W 68 ohms (J)	35-11-19
9-IC3	EI304165	IC MB400M	45-8-252	9-R175	ER313528	Metal Oxide Film/R. 2W 27 ohms (J)	35-11-19
9-IC4	EI304166	IC MB418	45-8-253	9-C9,10	EC313532	NP/C. 1 $\mu$ F(M) 50WV	24-17-31
9-IC5	EI313694	IC MB401	45-8-329	9-C16,17	EC313532	NP/C. 1 $\mu$ F(M) 50WV	24-17-31
9-IC6	EI305238	IC MB417M	45-8-255	9-C22	EC313781	NP/C. 10 $\mu$ F(M) 6.3WV	24-17-31
9-IC7,8	EI305237	IC MB402	45-8-254	9-C25	EC313781	NP/C. 10 $\mu$ F(M) 6.3WV	24-17-31
9-IC9	EI304165	IC MB400M	45-8-252	9-C28to31	EC313533	NP/C. 4.7 $\mu$ F(M) 16WV	24-17-31
9-IC10	EI305237	IC MB402	45-8-254	9-C32	EC304736	Tantalum/C. (DTS) 47 $\mu$ F(K) 6.3WV	24-15-8
9-IC11	EI304165	IC MB400M	45-8-252	9-C43,44	EC308940	NP/C. 0.47 $\mu$ F(M) 50WV	24-17-31
9-IC12	EI313694	IC MB401	45-8-329	9-C47	EC313533	NP/C. 4.7 $\mu$ F(M) 16WV	24-17-31
9-TR1to9	ET639437	Transistor 2SC945L(Q)(P)	45-1-85	9-C48	EC313536	Tantalum/C. (DTS) 15 $\mu$ F(K) 10WV	24-15-8
9-TR10	ET635220	Transistor 2SC945L(K)(P)	45-1-85				
9-TR11,12	ET639437	Transistor 2SC945L(Q)(P)	45-1-85				
9-TR13	ET635220	Transistor 2SC945L(K)(P)	45-1-85				
9-TR14	ET638504	Transistor 2SC945L(P)	45-1-85				
9-TR15	ET639437	Transistor 2SC945L(Q)(P)	45-1-85				
9-TR16	ET635220	Transistor 2SC945L(K)(P)	45-1-85				
9-TR17	ET638504	Transistor 2SC945L(P)	45-1-85				
9-TR18to22	ET639437	Transistor 2SC945L(Q)(P)	45-1-85				
9-TR23,24	ET635220	Transistor 2SC945L(K)(P)	45-1-85				
9-TR25	ET638504	Transistor 2SC945L(P)	45-1-85				
9-TR26	ET635220	Transistor 2SC945L(K)(P)	45-1-85				
9-TR27	ET638504	Transistor 2SC945L(P)	45-1-85				
9-TR28to33	ET639437	Transistor 2SC945L(Q)(P)	45-1-85				
9-TR34,35	ET302502	Transistor 2SC2001(K)	45-1-272				
9-TR36	ET639437	Transistor 2SC945L(Q)(P)	45-1-85				
9-TR37,38	ET638504	Transistor 2SC945L(P)	45-1-85				
9-TR39,40	ET639437	Transistor 2SC945L(Q)(P)	45-1-85				
9-TR46,47	ET313525	Transistor 2SB605(K)	45-1-225				
9-TR48to51	ET208012	Transistor 2SD571(K)	45-1-218				
9-TR52to56	ET639437	Transistor 2SC945L(Q)(P)	45-1-85				
9-TR57	ET292375	Transistor 2SD360(E)	45-1-142				
9-D1to6	ED560913	Silicon Diode 1S2473 VE	45-3-23				
9-D7	ED308952	Germanium Diode 1K34A-LR	45-3-47				
9-D8	ED560913	Silicon Diode 1S2473 VE	45-3-23				
9-D9	ED309341	Germanium Diode 1K34A	45-3-45				
9-D10to15	ED308952	Germanium Diode 1K34A-LR	45-3-47				
9-D16to19	ED560913	Silicon Diode 1S2473 VE	45-3-23				
9-D20	ED309341	Germanium Diode 1K34A	45-3-45				
9-D21	ED308952	Germanium Diode 1K34A-LR	45-3-47				
9-D22	ED560913	Silicon Diode 1S2473 VE	45-3-23				
9-D23to25	ED308952	Germanium Diode 1K34A-LR	45-3-47				
9-D26to29	ED560913	Silicon Diode 1S2473 VE	45-3-23				
9-D30,31	ED308952	Germanium Diode 1K34A-LR	45-3-47				
9-D32to40	ED560913	Silicon Diode 1S2473 VE	45-3-23				
9-D41,42	ED308952	Germanium Diode 1K34A-LR	45-3-47				
9-D43	ED560913	Silicon Diode 1S2473 VE	45-3-23				
9-D44	ED308952	Germanium Diode 1K34A-LR	45-3-47				
9-D45to51	ED560913	Silicon Diode 1S2473 VE	45-3-23				
9-D56	ED308952	Germanium Diode 1K34A-LR	45-3-47				
9-D57to60	ED560913	Silicon Diode 1S2473 VE	45-3-23				
9-D61	ED309341	Germanium Diode 1K34A	45-3-45				
9-D62to64	ED560913	Silicon Diode 1S2473 VE	45-3-23				
9-D65	ED308952	Germanium Diode 1K34A-LR	45-3-47				
9-D66	ED560913	Silicon Diode 1S2473 VE	45-3-23				
9-D67to69	ED308952	Germanium Diode 1K34A-LR	45-3-47				
9-D71	ED309341	Germanium Diode 1K34A	45-3-45				
9-D72	ED308952	Germanium Diode 1K34A-LR	45-3-47				
9-D73	ED560913	Silicon Diode 1S2473 VE	45-3-23				

When ordering parts, please describe Parts Number, Description, and Model Number in detail.

## 10. POWER SUPPLY P.C BOARD (CX-5002A) BLOCK

Symbol No.	Parts No.	Description	Schematic No.
10-1	BA311460	Power Supply P.C Board Comp. GXC-735D (U/T, CEE, UK)	CX-5002A
10-2	BA311461	Power Supply P.C Board Comp. GXC-735D (JPN)	CX-5002A
10-3	BA311462	Power Supply P.C Board Comp. GXC-735D (CSA)	CX-5002A
10-4	BA311463	Power Supply P.C Board Comp. GXC-735D (AAL)	CX-5002A
10-5	ZS325495	Tapping Screw, #2, 3x6 (BR)	
10-SCR1	ED313513	Thyristor SFOR1B41	45-13-4
10-TR1	ET311868	Transistor 2SC2130(F)(G)	45-1-317
10-TR2	ET307349	Transistor 2SD794(P)(Q)	45-1-334
10-TR3	ET311868	Transistor 2SC2130(F)(G)	45-1-317
10-TR4	ET307349	Transistor 2SD794(P)(Q)	45-1-334
10-TR5to7	ET311868	Transistor 2SC2130(F)(G)	45-1-317
10-TR8	ET313514	Transistor 2SD386(E)(F)	45-1-352
10-TR9	ET305463	Transistor 2SA970(GR)(BL)	45-1-303
10-TR10	ET311868	Transistor 2SC2130(F)(G)	45-1-317
10-TR11	ET313728	Transistor 2SB560(F)	45-1-232
10-TR12	ET311868	Transistor 2SC2130(F)(G)	45-1-317
10-TR13	ET219857	Transistor 2SD438(E)(F)	45-1-233
10-TR14	ET311868	Transistor 2SC2130(F)(G)	45-1-317
10-TR15	ET313728	Transistor 2SB560(F)	45-1-232
10-TR16	ET311868	Transistor 2SC2130(F)(G)	45-1-317
10-TR17	ET219857	Transistor 2SD438(E)(F)	45-1-233
10-TR18	ET311868	Transistor 2SC2130(F)(G)	45-1-317
10-TR19	ET313728	Transistor 2SB560(F)	45-1-232
10-TR20	ET311868	Transistor 2SC2130(F)(G)	45-1-317
10-TR21	ET219857	Transistor 2SD438(E)(F)	45-1-233
10-TR22	ET311868	Transistor 2SC2130(F)(G)	45-1-317
10-TR23	ET313728	Transistor 2SB560(F)	45-1-232
10-TR24	ET311868	Transistor 2SC2130(F)(G)	45-1-317
10-TR25	ET219857	Transistor 2SD438(E)(F)	45-1-233
10-TR26	ET311868	Transistor 2SC2130(F)(G)	45-1-317
10-TR27	ET219857	Transistor 2SD438(E)(F)	45-1-233
10-TR28to35	ET639437	Transistor 2SC945L(Q)(P)	45-1-85
10-D1	ED309357	Silicon Diode SVB15-100	45-2-83
10-D2	ED308945	Silicon Diode SVB10-100	45-2-82
10-D3	ED309357	Silicon Diode SVB15-100	45-2-83
10-D4	ED314698	Zener Diode UZ-6.2B	45-6-84
10-D5	ED306109	Silicon Diode W03B	45-2-78
10-D6	ED315354	Zener Diode UZ-19B	45-6-84
10-D7	ED310541	Zener Diode (Vert.) UZ-19BLR	45-6-85
10-D8	ED313730	Zener Diode (Vert.) UZ-16BLR	45-6-85
10-D9	ED306109	Silicon Diode W03B	45-2-78
10-D10	ED308952	Germanium Diode 1K34A-LR	45-3-47
10-D11	ED560913	Silicon Diode 1S2473 VE	45-3-23
10-D12,13	ED306109	Silicon Diode W03B	45-2-78
10-D14	ED560913	Silicon Diode 1S2473 VE	45-3-23
10-D15,16	ED306109	Silicon Diode W03B	45-2-78
10-D17	ED560913	Silicon Diode 1S2473 VE	45-3-23
10-D18,19	ED306109	Silicon Diode W03B	45-2-78
10-D20	ED560913	Silicon Diode 1S2473 VE	45-3-23
10-D21to23	ED306109	Silicon Diode W03B	45-2-78
10-D24to29	ED560913	Silicon Diode 1S2473 VE	45-3-23
10-D30	ED313730	Zener Diode (Vert.) UZ-16BLR	45-6-85
10-R3	ER313515	Metal Oxide Film/R. 1W 1.5K (J)	35-11-21
10-R10	ER313517	Metal Oxide Film/R. 2W 2.2K (J)	35-11-22
10-R17	ER538626	Metal Oxide Film/R. 3W 150 ohms (K)	35-15-9
10-R25	ER313519	Metal Oxide Film/R. 2W 100 ohms (J)	35-11-19
10-R33	ER313519	Metal Oxide Film/R. 2W 100 ohms (J)	35-11-19

Symbol No.	Parts No.	Description	Schematic No.
10-R41	ER313518	Metal Oxide Film/R. 2W 240 ohms (J)	35-11-19
10-R46	ER313521	Metal Oxide Film/R. 2W 3.3 ohms (J)	35-11-22
10-R52	ER356411	Metal Oxide Film/R. 1W 680 ohms (K)	35-15-10
10-C1	EC307260	Elect./C. (Vert.) 3300μF 16WV	24-12-30
10-C5	EC295997	Elect./C. (Vert.) 2200μF 35WV	24-12-9
10-C11	EC313520	Elect./C. (Vert.) 2200μF 63WV	24-12-44
10-C23	EC308940	NP/C. 0.47μF(M) 50WV	24-17-31
10-C29	EC301320	Δ MP/C. 4700PF (M) 250WV (U/T,CEE,UK)	24-9-122
10-C29	EC551160	Δ Ceramic/C. DB821 NA 0.01μF (Z) 1.4kW (JPN)	24-5-55
10-C29	EC294118	Δ Ceramic/C. DPN6600 YM 0.01μF (P) 125W (CSA)	24-5-70
10-C29	EC305737	Δ Ceramic/C. LB832 Z 0.01μF (Z) 125WV (AAL)	24-5-75
10-C30	EC301320	Δ MP/C. 4700PF (M) 250WV (U/T,CEE,UK)	24-9-122

## 11. VOL. P.C BOARD (CX-5003) BLOCK

Symbol No.	Parts No.	Description	Schematic No.
11-1	BA311478	Vol. P.C Board Comp. GXC-735D	CX-5003
11-VR1,2	EV313693	Double Axial 2 throw Vol. DM20R 100kA x2	36-5-5
11-VR9	EV523214	Semi-fixed/Vol. V8K1-1 5kB	36-10-267
11-TR2,3	ET399846	Transistor 2SC945L(Q)	45-1-85
11-TR4	ET639437	Transistor 2SC945L(Q)(P)	45-1-85
11-TR5	ET399846	Transistor 2SC945L(Q)	45-1-85
11-TR6	ET639437	Transistor 2SC945L(Q)(P)	45-1-85
11-TR7	ET554657	Transistor 2SA733(P)(Q)	45-1-124
11-D1	ED560913	Silicon Diode 1S2473 VE	45-3-23
11-D3,4	ED308952	Germanium Diode 1K34A-LR	45-3-47
11-D5	ED560913	Silicon Diode 1S2473 1S2473 VE	45-3-23
11-R2	ER466380	Carbon/R. RD1/2 1K(J)	35-9-9

## 12. ILLUSTRATION OF ASSEMBLY BLOCK

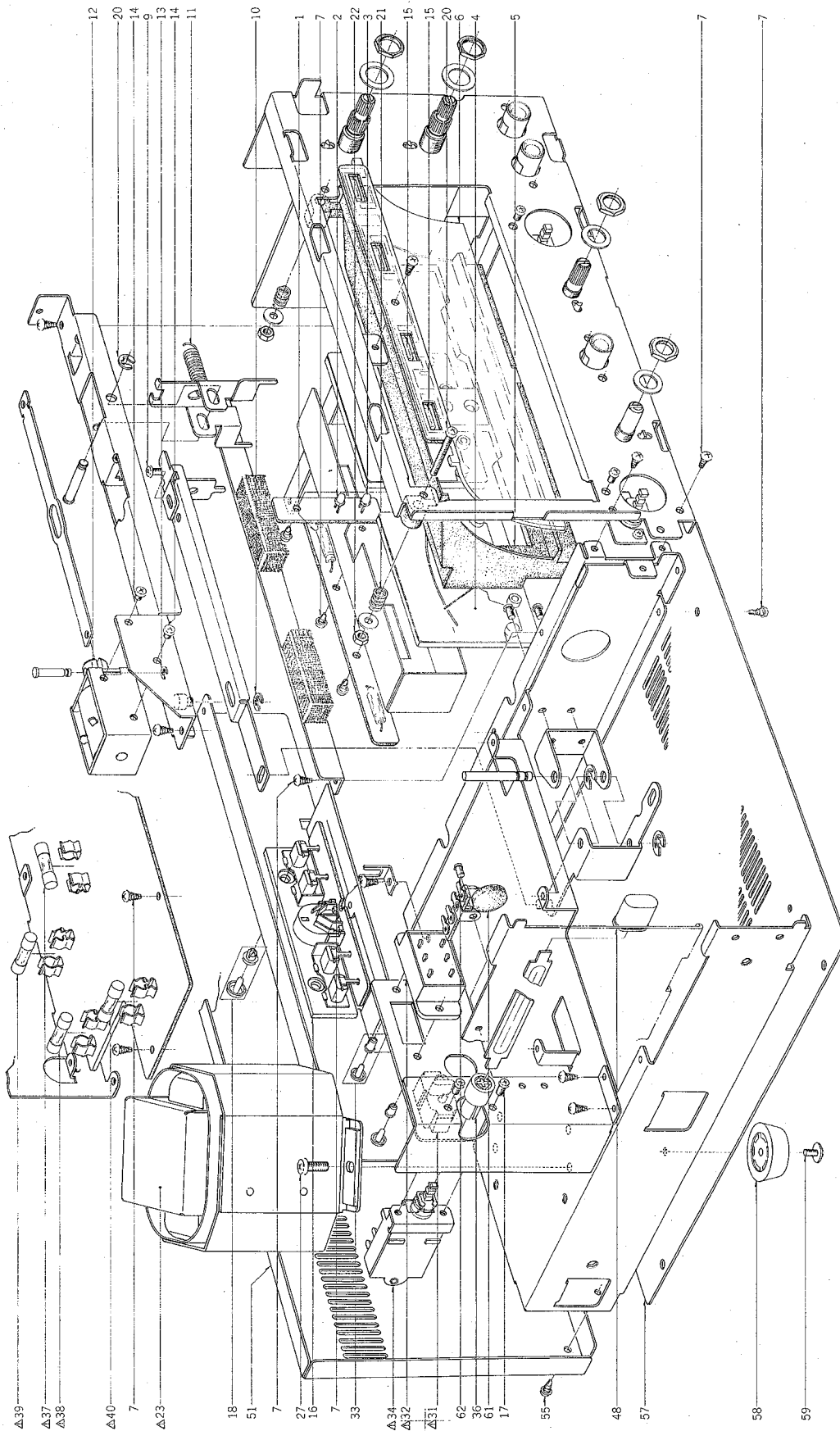

## 12. ASSEMBLY BLOCK

Ref. No.	Parts No.	Description	Schematic No.
<b>METER LAMP P.C BOARD BLOCK</b>			
12-1	EL313491	Lamp (Lead type) 15V 100mA	28-2-73
<b>PEAK P.C BOARD BLOCK</b>			
12-2	ED249377	LED GL-3AR1	45-15-14
12-3	ED303005	LED GL-3PY1	45-15-18
<b>METER BLOCK</b>			
12-4	EM313546	VU Meter C60A0R	46-1-212
12-5	BC313715	Case	46-1-212
12-6	BC313716	Cover	46-1-212
12-7	ZS325495	Tapping Screw, #2 3x6 (BR)	
<b>SW. P.C BOARD BLOCK</b>			
12-8x	ES313500	Slide SW. CL202E	25-3-162
<b>REC CHANGE BLOCK</b>			
12-9	ZS323728	Screw, bind 3x5	
12-10	ZW270101	'E' Ring 3M	6-1-9
12-11	ZG313084	Coil Spring T1-6.3/0.8-22.4	
12-12	EP323498	Plunger 1037THTI	44-1-102
12-13	ZW270088	'E' Ring 1.9M	6-1-9
12-14	ZS432674	Screw, pan 3x3	
<b>DIRECTION P.C BOARD BLOCK</b>			
12-15	EL313491	Lamp (Lead type) 15V 100mA	28-2-73
<b>JACK P.C BOARD BLOCK</b>			
12-16	EJ306985	4P Pin Jack	31-5-142
<b>AMP BLOCK</b>			
12-17	ZS422076	Screw, pan 3x5	
12-18	ZW263946	Nylon Rivet 4x5	2-7-57
12-19	ZS290597	Tapping Screw, #2, 3x8 (BR) (W=10)	
12-20	ZS608264	Screw, pan 3x25	
12-21	ZG375232	Guide Spring S	PX 827
12-22	ZW516993	Nut M3, #1	
<b>POWER SUPPLY CHASSIS BLOCK</b>			
12-23	BT313508	△ Power Trans. CXT-3 (U/T, CEE, UK)	38-4-672
12-24x	BT313507	△ Power Trans. CXT-2 (JPN)	38-4-671
12-25x	BT313510	△ Power Trans. CXT-5 (CSA)	38-4-674
12-26x	BT313509	△ Power Trans. CXT-4 (AAL)	38-4-673
12-27	ZS301576	S-Tight Screw, pan 4x10	
12-28x	EW306427	△ AC Cord (JPN)	26-3-63
12-29x	EW305691	△ AC Cord CUL (CSA, AAL)	26-3-65
12-30x	EZ631945	△ Strain Relief SR-4N-4 (JPN, CSA, AAL)	2-7-49
12-31	EJ301513	△ 2P Inlet (U/T)	31-1-200
12-32	ES309312	Slide SW. 22293B	25-3-150
12-33	ZW231030	Nylon Rivet (FNRP) 3x4.5 (Black)	2-7-54
12-34	ES309058	△ Push SW. JP-24 (U/T, CEE, UK)	25-5-286
12-35x	ES309059	△ Push SW. JP-27 (JPN)	25-5-285
12-36	TC289484	SW. Joint	CM-6015
12-37	EF602550	△ Fuse (SEMKO T Type) 1.25AT 250V (U/T, CEE, UK)	39-1-53
12-38	EF601964	△ Fuse (SEMKO T Type) 1.6AT (U/T, CEE, UK)	39-1-53
12-39	EF668474	△ Fuse (SEMKO T Type) 400MAT (U/T, CEE, UK)	39-1-53
12-40	EF258344	△ Fuse (SEMKO T Type) 800MAT (U/T, CEE, UK)	39-1-53
12-41x	EF616555	△ Fuse 1.6A 250V (JPN)	39-1-50
12-42x	EF563670	△ Fuse 0.5A 250V (JPN)	39-1-50
12-43x	EF659711	△ Fuse ST-6 1.6A (CSA, AAL)	39-1-63
12-44x	EF313489	△ Fuse ST-6 0.5A (CSA, AAL)	39-1-63
12-45x	ZS417216	Screw, pan 3x4	
<b>ASSEMBLY BLOCK</b>			
12-46x	ZS447840	Tapping Screw #2, 3x8 (BR)	

Ref. No.	Parts No.	Description	Schematic No.
12-47x	ZS308895	S-tight Screw, pan 3x8	
12-48	SK305674	Power SW. Cap	CN-6338
12-49x	SK314618	Power SW. Cap (B) (JPN)	CN-6338
12-50x	SK306130	Power SW. Cap (BL)	CN-6338
12-51	SP313483	Rear Panel (U, E, B) (U/T, CEE, UK)	CX-6019, 6024
12-52x	SP313478	Rear Panel (J) (JPN)	CX-6019, 6021
12-53x	SP313480	Rear Panel (C) (CSA)	CX-6019, 6022
12-54x	SP313482	Rear Panel (A) (AAL)	CX-6019, 6023
12-55	ZS447761	Tapping Screw, #2 3x6 (BR) (Black)	
12-56	ZW305013	POP Rivet D3.2	7-6-9
12-57	SP313475	Bottom Plate	CX-6017
12-58	SA306240	Rubber Foot (B)	LE-6740
12-59	ZS313486	S-Tight Screw, pan 3x6 w/flange	
12-60x	EW306152	AC Cord Set U/T Type 2	26-3-71
12-61	ED-650968	Thermister (Sine) PTH62AR 100M	45-14-3
12-62	ED249377	LED GL-3AR1	45-15-14



### 13. PHOTO OF FINAL ASSEMBLY BLOCK

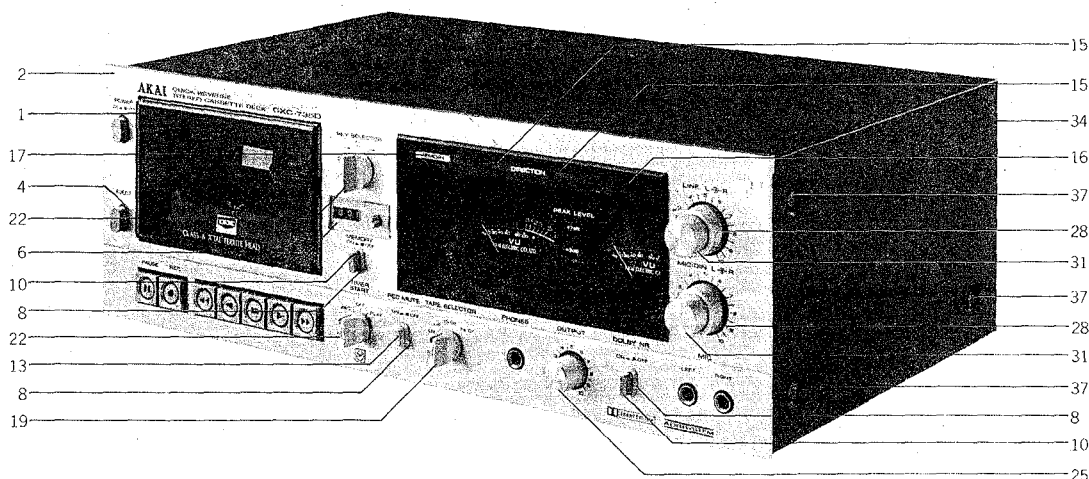

### 13. FINAL ASSEMBLY BLOCK

Ref. No.	Parts No.	Description	Schematic No.	Ref. No.	Parts No.	Description	Schematic No.
<b>LID PANEL BLOCK</b>				13-23x	SK314619	Knob (E)	CX-6027
13-1	BD312281	LID Panel Block Comp. GXC-735D		13-24x	SK309300	Knob (B-BL)	CX-6014
<b>FRONT PANEL BLOCK</b>				13-25	SK308419	Knob (A) Part GXC-715D	CX-6008
13-2	BD312279	Front Panel Block Comp. GXC-735D		13-26x	SK314533	Knob (D) Part GXC-735D(JPN)	CX-6026
13-3x	SP313463	Lower Panel	CX-6003,6004	13-27x	SK308491	Knob (A-BL) Part GXC-715D	CX-6008
13-4	SE309648	Button Escutcheon	CY-6014	13-28	SK311522	Double Knob (Lower) Part GXC-735D	CX-6009
13-5x	ZS325495	Tapping Screw, #2, 3x6 (BR)		13-29x	SK311115	Double Knob (Lower-2) Part GXC-735D (JPN)	CX-6029
13-6	SE310781	Counter Escutcheon	CY-6016	13-30x	SK311524	Double Knob (Lower-BL) Part GXC-735D-BL	CX-6009
13-7x	SE310782	Counter Escutcheon (BL)	CY-6016	13-31	SK311525	Double Knob (Upper) Part GXC-735D	CX-6010
13-8	SE305651	Button Escutcheon (B)	CN-6352	13-32x	SK311116	Double Knob (Upper-2) Part GXC-735D (JPN)	CX-6030
13-9x	SE306936	Button Escutcheon (B-BL)	CN-6352	13-33x	SK311526	Double Knob (Upper-BL) Part GXC-735D-BL	CX-6010
13-10	SK305653	Push Button (A)	CN-6309	13-34	BC305744	Upper Cover (A)	CN-6323
13-11x	SK314617	Push Button (E) (JPN)	CN-6309	13-35x	BC305743	Upper Cover (B) (AAL)	CN-6323
13-12x	SK305656	Push Button (D) (BL)	CN-6309	13-36x	ZS447761	Tapping Screw, #2, 3x6 (BR) (Black)	
13-13	SK305654	Push Button (B) (EXT. JPN)	CN-6309	13-37	ZS310588	S-Tight Screw, bind 4x8 (Black)	
13-14x	ZG305657	Button Spring	CN-6310				
13-15	TC310796	Direction Plate	CY-6031	13-38x	BD314625	Front Panel Block Comp. GXC-735D (JPN)	
13-16	SE313464	Escutcheon (A)	CX-6005,6006	13-39x	BD312280	Front Panel Block Comp. GXC-735D-BL	
13-17	SE313465	Escutcheon (B)	CX-6005,6020				
13-18x	ZS455207	Tapping Screw #2, 3x5 (BR)					
<b>ASSEMBLY BLOCK</b>							
13-19	SK313472	Knob (C)	CX-6015				
13-20x	SK314620	Knob (F)	CX-6028				
13-21x	SK313473	Knob (C-BL)	CX-6015				
13-22	SK309255	Knob (B)	CX-6014				

When ordering parts, please describe Parts Number, Description, and Model Number in detail.

# INDEX

Parts No.	Ref. No. & Symbol No.	Parts No.	Ref. No. & Symbol No.	Parts No.	Ref. No. & Symbol No.	Parts No.	Ref. No. & Symbol No.
SK311116	13-32x	ZS417216	12-45x				
SK311522	13-28	ZS422076	4-4				
SK311524	13-30x	ZS422076	6-43				
SK311525	13-31	ZS422076	7-9				
SK311526	13-33x	ZS422076	12-17				
SK313472	13-19	ZS430413	3-9				
SK313473	13-21x	ZS432674	6-34				
SK314533	13-26x	ZS432674	7-2				
SK314617	13-11x	ZS432674	12-14				
SK314618	6-14x	ZS432843	6-45				
SK314618	12-49x	ZS433001	2-21				
SK314619	13-23x	ZS447761	12-55				
SK314620	13-20x	ZS447761	13-36x				
SP313463	13-3x	ZS447840	12-46x				
SP313475	12-57	ZS455207	13-18x				
SP313478	12-52x	ZS460440	2-30				
SP313480	12-53x	ZS477876	6-28				
SP313482	12-54x	ZS479474	4-11				
SP313483	12-51	ZS479474	6-48				
SZ313412	6-57	ZS530684	6-60				
TC289484	12-36	ZS590804	2-5				
TC309145	6-47	ZS592378	2-2				
TC309154	6-31	ZS592378	3-15				
TC310796	13-15	ZS592378	7-12				
TC311515	5-6	ZS608095	7-21				
TC315597	6-32	ZS608174	2-3				
TC645186	6-59	ZS608264	12-20				
ZG305657	13-14x	ZS608275	7-10				
ZG309225	3-5	ZS608477	5-8				
ZG309226	3-7	ZW231030	12-33				
ZG312948	7-8	ZW259650	2-23				
ZG312996	6-22	ZW259773	6-19				
ZG312996	7-5	ZW263946	12-18				
ZG313084	12-11	ZW270088	3-2				
ZG313314	2-17	ZW270088	6-23				
ZG313316	2-24	ZW270088	7-3				
ZG313342	7-19	ZW270088	12-13				
ZG313361	6-52	ZW270101	6-16				
ZG313376	5-5	ZW270101	7-13				
ZG313386	6-33	ZW270101	12-10				
ZG313390	6-27	ZW270123	6-21				
ZG313392	3-4	ZW273734	2-18				
ZG313407	7-16	ZW290283	2-28				
ZG313423	5-3	ZW290283	3-16				
ZG313691	2-27	ZW290283	6-24				
ZG313874	2-25	ZW290283	7-4				
ZG315481	3-12	ZW300888	2-26				
ZG369088	2-6	ZW303680	4-3				
ZG369088	2-20	ZW305013	12-56				
ZG375232	12-21	ZW313419	4-6				
ZG465636	2-11	ZW313501	2-14				
ZG469315	3-10	ZW315745	6-55x				
ZG525993	3-3	ZW316635	6-56x				
ZG576314	2-29	ZW356657	6-51				
ZG580263	7-14	ZW356657	7-15				
ZS201508	2-10	ZW432753	3-11				
ZS267254	6-58	ZW474581	3-18				
ZS290597	12-19	ZW516611	5-2				
ZS301576	12-27	ZW516993	6-18				
ZS302318	4-2	ZW516993	12-22				
ZS308895	12-47x	ZW560215	6-20				
ZS310588	13-37						
ZS313486	12-59						
ZS313823	3-8x						
ZS323728	7-18						
ZS323728	12-9						
ZS325495	10-5						
ZS325495	12-7						
ZS325495	13-5x						
ZS355544	6-38						
ZS375107	2-8						
ZS375107	5-4						
ZS379350	4-9						
ZS391408	2-12						
ZS391522	2-13						
ZS391522	2-19						
ZS4117216	5-7						
ZS417216	6-26						
ZS417216	7-7						
ZS417216	8-2						

---

SECTION 3

**SCHEMATIC DIAGRAM**

1. GXC-735D NO. 3-1 1580848A PRE AMP SCHEMATIC DIAGRAM
2. GXC-735D NO. 3-2 1580849A SYS. CON SCHEMATIC DIAGRAM
3. GXC-735D NO. 3-3 1580850A POWER SUPPLY SCHEMATIC DIAGRAM

GXC-735D

LEFT

RIGHT

JACK P.C BOARD CX-5004B

VOLUME P.C BOARD CX-5003

PRE AMP P.C BOARD CX-5004A

NOTE  
 1 UNLESS OTHERWISE SPECIFIED  
 ALL RESISTORS IN OHMS (4W(J))  
 ALL CAPACITORS IN µF 50WV(J)  
 2 -M- MARK INDICATES BIPOLAR (BP) ELECTROLYTIC CAPACITORS  
 3 (LL)= LOW LEAKAGE CAPACITORS

GXC-735D PRE  
 SCHEMATIC DIAGRAM  
 NO.3-1 1580848A

001024F

2c

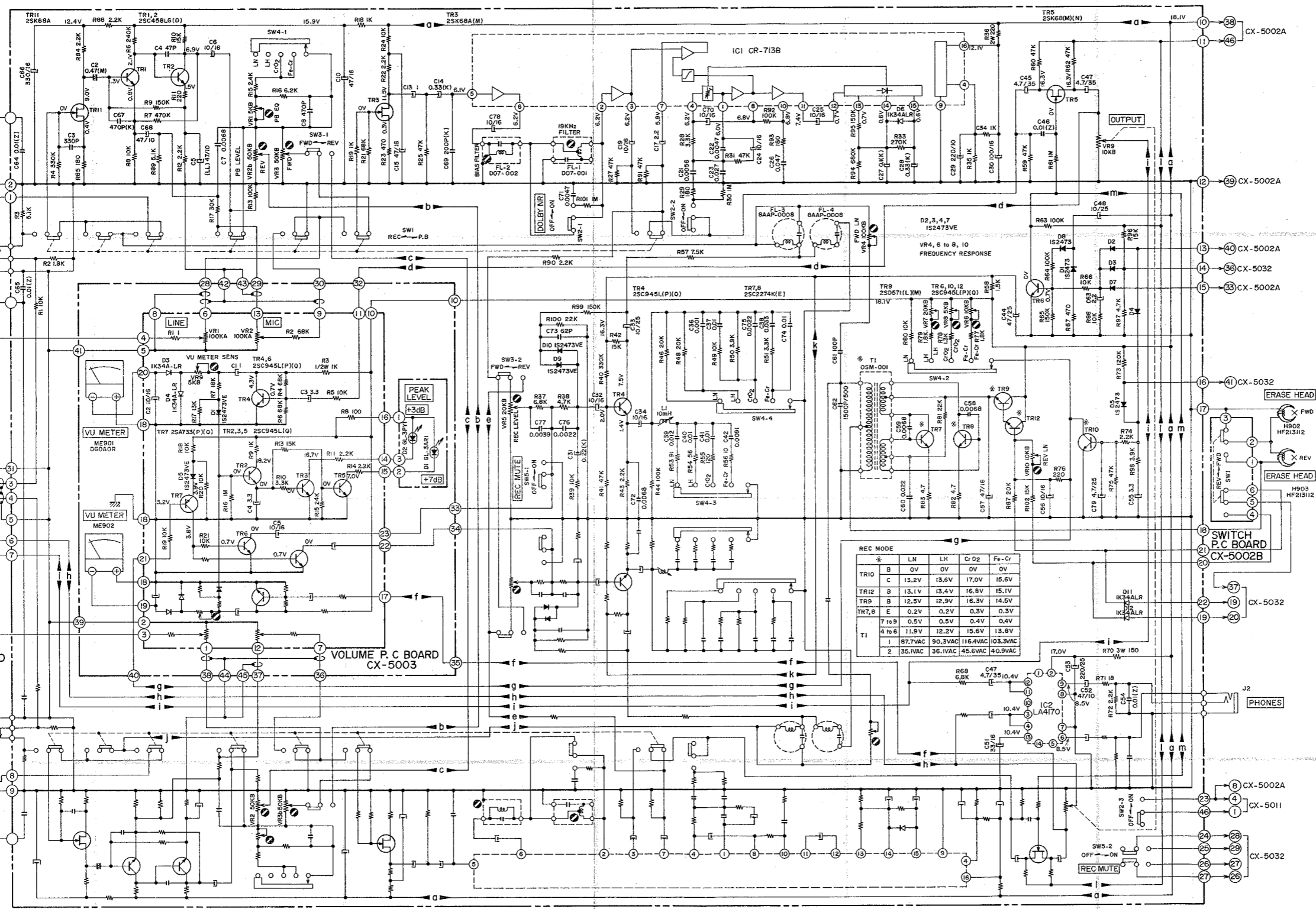

GXC-735D

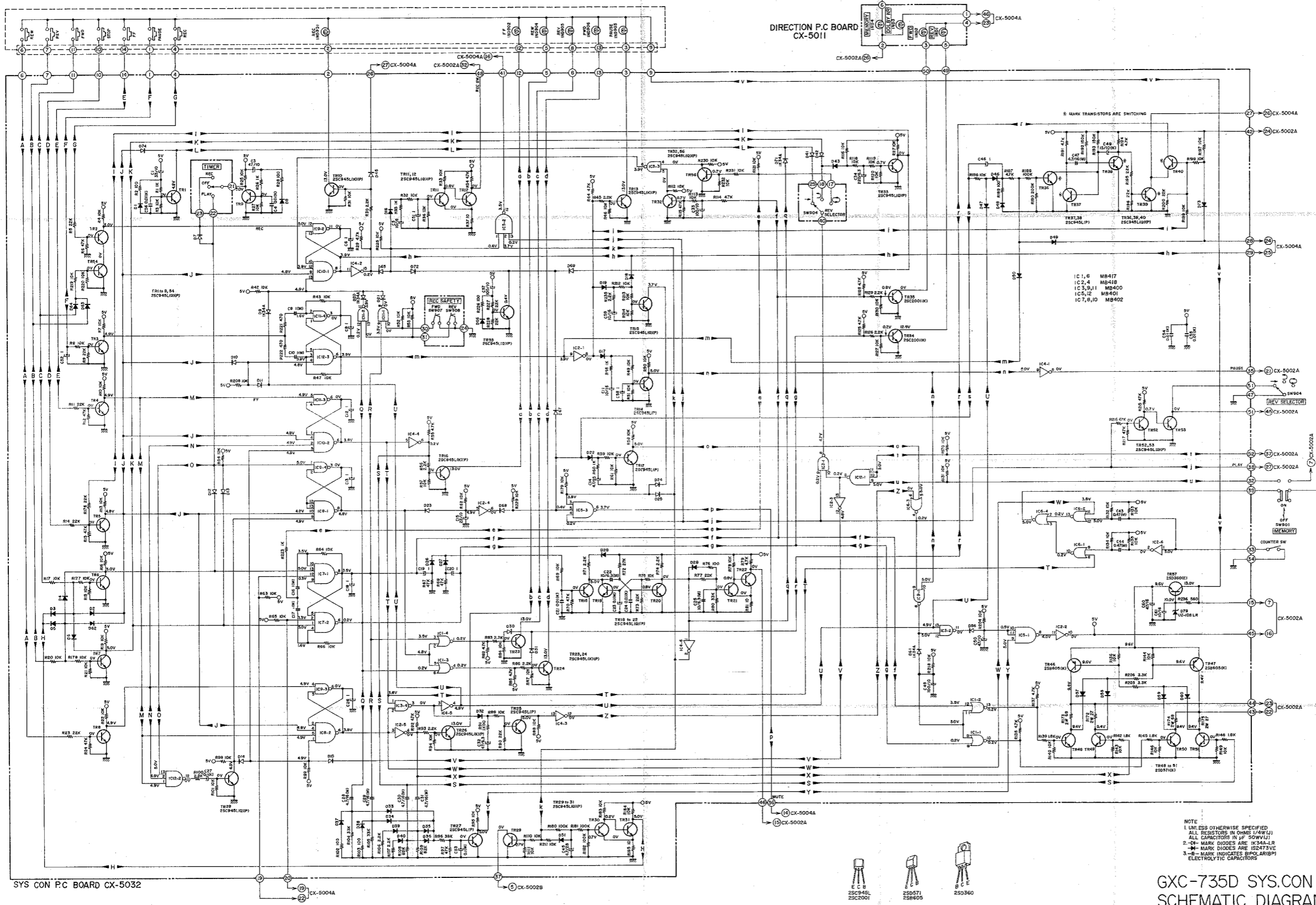

DIRECTION P.C. BOARD  
CX-5011

SYS CON P.C. BOARD CX-5032

NOTE  
 1. UNLESS OTHERWISE SPECIFIED  
 ALL RESISTORS IN OHMS /4W/1J  
 ALL CAPACITORS IN μF 50V/1J  
 2. MARK DIODES ARE 1N34A-1P  
 3. MARK DIODES ARE 1N247-3V  
 4. MARK INDICATES BPC4R18P  
 ELECTROLYTIC CAPACITORS

GXC-735D SYS.CON  
 SCHEMATIC DIAGRAM  
 NO.3-2 1580849A



GXC-735D

LAMP P.C BOARD  
CX-5002E

METER LAMP P.C BOARD  
CX-5014

CAPSTAN MOTOR

DETECTION P.C BOARD  
CY-0023

REEL MOTOR

POWER SUPPLY P.C BOARD CX-5002A

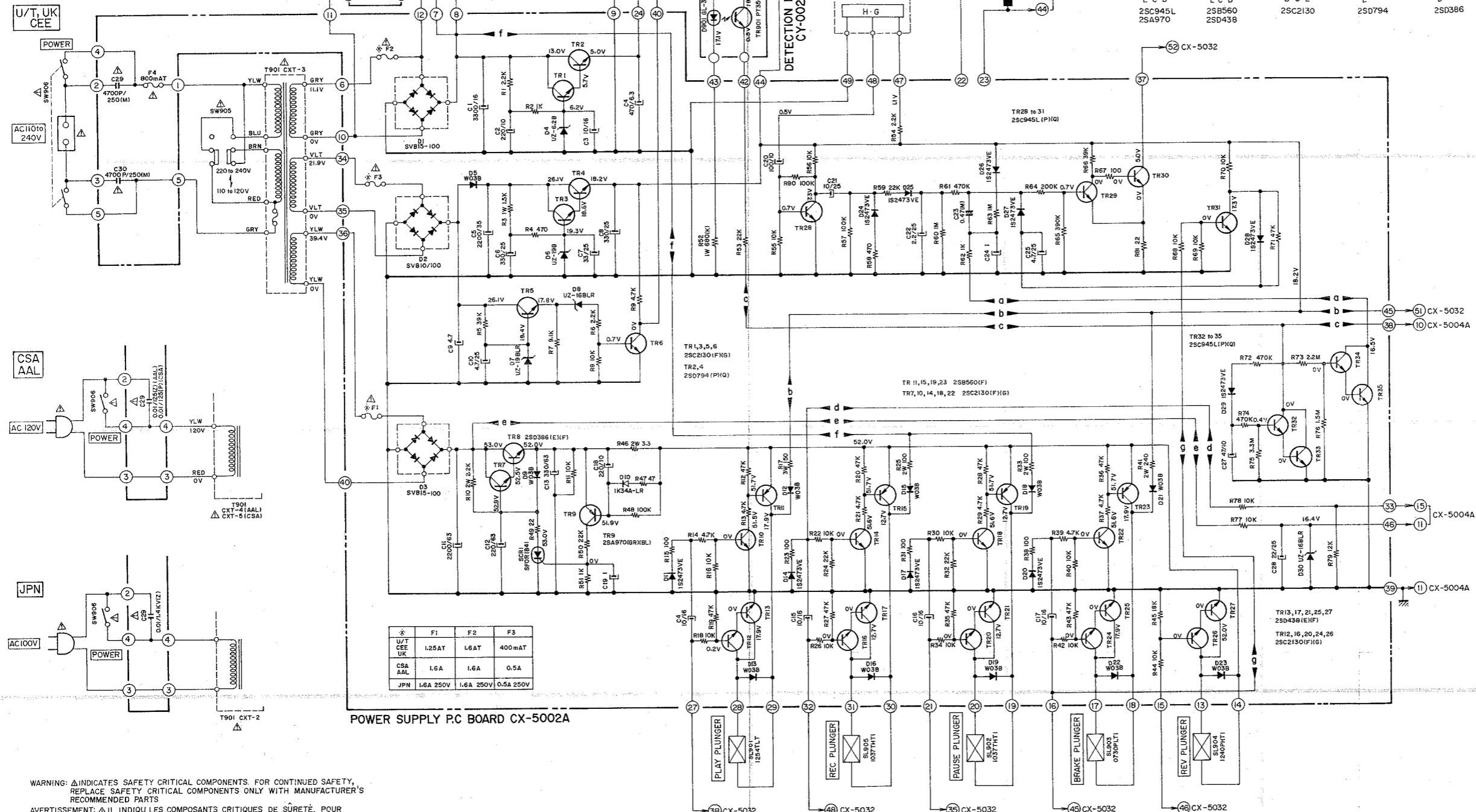

	F1	F2	F3
U/T CEE	1.25A T	1.6A T	400mA T
CSA AAL	1.6A	1.6A	0.5A
JPN	1.6A 250V	1.6A 250V	0.5A 250V

WARNING: Δ INDICATES SAFETY CRITICAL COMPONENTS. FOR CONTINUED SAFETY, REPLACE SAFETY CRITICAL COMPONENTS ONLY WITH MANUFACTURER'S RECOMMENDED PARTS.

AVERTISSEMENT: Δ IL INDIQUE LES COMPOSANTS CRITIQUES DE SÛRETÉ. POUR MAINTENIR LE DEGRÉ DE SÛRETÉ DE L'APPAREIL NE REMPLACER LES COMPOSANTS DONT LE FONCTIONNEMENT EST CRITIQUE POUR LA SÛRETÉ QUE PAR DES PIÈCES RECOMMANDÉES PAR LE FABRICANT.

NOTE  
 1. UNLESS OTHERWISE SPECIFIED ALL RESISTORS IN OHMS 1/4W (J) ALL CAPACITORS IN μF 50WV (J)  
 2. -#- INDICATES BIPOLAR CAPACITORS  
 3. POWER TRANSFORMER IS DIFFERENT ACCORDING TO AREA

GXC-735D  
 POWER SUPPLY  
 SCHEMATIC DIAGRAM  
 NO.3-3 1580850A

#### 14. LIST OF INTERCHANGEABLE SEMICONDUCTORS

If, while servicing, the original parts cannot be obtained, the interchangeable parts listed below can be substituted.

Original Parts			Interchangeable Parts	
Description	Parts No.	Utilizing P.C Board	Description	Parts No.
2SA733 (P) (Q)	ET554657	CX-5003	2SA640 (E) (F)	ET623790
2SC945L (Q)	ET399846	CX-5003	2SC711 (E)	ET380834
2SC945L (Q) (P)	ET639437	CX-5002A CX-5003 CX-5004A CX-5032	2SC711 (E) (F)	ET453480
1K34A-LR	ED308952	CX-5003 CX-5004A CX-5032	1N34A	ED219464
W03B	ED306109	CX-5002A CX-5032	10D1	ED224526

# INDEX

Parts No.	Ref. No. & Symbol No.	Parts No.	Ref. No. & Symbol No.	Parts No.	Ref. No. & Symbol No.	Parts No.	Ref. No. & Symbol No.
BA311460	10-1	ED308952	10-D10	ER309119	8-FL1	ET639437	8-TR10
BA311461	10-2	ED308952	11-D3,4	ER309361	8-FL2	ET639437	8-TR12
BA311462	10-3	ED309341	9-D9	ER313515	10-R3	ET639437	9-TR1to9
BA311463	10-4	ED309341	9-D20	ER313517	10-R10	ET639437	9-TR11,12
BA311478	11-1	ED309341	9-D61	ER313518	10-R41	ET639437	9-TR15
BA311483	8-1	ED309341	9-D71	ER313519	10-R25	ET639437	9-TR18to22
BA314296	9-1	ED309357	10-D1	ER313519	10-R33	ET639437	9-TR28to33
BC305743	13-35x	ED309357	10-D3	ER313521	10-R46	ET639437	9-TR36
BC305744	13-34	ED310541	10-D7	ER313528	9-R172	ET639437	9-TR39, 40
BC313715	12-5	ED313513	10-SCR1	ER313528	9-R175	ET639437	9-TR52to56
BC313716	12-6	ED313730	10-D8	ER313699	8-R36	ET639437	10-TR28to35
BD312279	13-2	ED313730	10-D30	ER313853	8-R70	ET639437	11-TR4
BD312280	13-39x	ED314698	10-D4	ER315355	9-R173,174	ET639437	11-TR6
BD312281	13-1	ED315221	9-D79	ER356411	10-R52	ET655356	8-TR9
BD314625	13-38x	ED315354	10-D6	ER466380	11-R2	EV305635	8-VR1
BF313347	4-7	ED560913	8-D2to4	ES38626	10-R17	EV305635	8-VR8
BF314499	4-5	ED560913	8-D7	ES302508	7-20	EV305636	8-VR2,3
BH308338	2-1	ED560913	8-D9,10	ES309058	12-34	EV305637	8-VR6
BK312300	6-1	ED560913	9-D1to6	ES309059	12-35x	EV305637	8-VR10
BK313305	6-61x	ED560913	9-D8	ES309312	12-32	EV305639	8-VR5
BL312508	6-49	ED560913	9-D16to19	ES309397	6-35	EV305639	8-VR7
BL312509	6-53	ED560913	9-D22	ES310827	8-SW3	EV305640	8-VR4
BL313549	6-50	ED560913	9-D26to29	ES313492	6-37	EV313538	8-VR9
BM312289	3-1	ED560913	9-D32to40	ES313493	6-39	EV313693	11-VR1,2
BM312302	4-1	ED560913	9-D43	ES313496	6-44	EV523214	11-VR9
BT313507	12-24x	ED560913	9-D45to51	ES313500	12-8x	EW305691	12-29x
BT313508	12-23	ED560913	9-D57to60	ES313537	8-SW5	EW306152	12-60x
BT313509	12-26x	ED560913	9-D62to64	ES313539	8-SW2	EW306427	12-28x
BT313510	12-25x	ED560913	9-D66	ES313732	8-SW1	EZ631945	12-30x
BZ311452	2-16	ED560913	9-D73	ES313734	6-36	HE314574	2-22
BZ312296	5-1	ED560913	10-D11	ES313735	8-SW4	HP-312298	2-9
EC294118	10-C29	ED560913	10-D14	ET208012	9-TR48to51	HZ313309	2-7
EC295997	10-C5	ED560913	10-D17	ET219857	10-TR13	HZ313313	2-15
EC301320	10-C29	ED560913	10-D20	ET219857	10-TR17	MB282104	3-6
EC301320	10-C30	ED560913	10-D24to29	ET219857	10-TR21	MB313387	4-8
EC304736	9-C32	ED560913	11-D1	ET219857	10-TR25	MB313388	6-46
EC305677	8-C69(L)	ED560913	11-D5	ET219857	10-TR27	MB313389	7-22
EC305737	10-C29	ED624903	8-D1	ET292375	9-TR57	MC313494	6-42x
EC307260	10-C1	ED624903	8-D5	ET301464	8-TR5	MC313495	6-40
EC308940	9-C43,44	ED624903	8-D8	ET302466	8-TR11	MC314712	6-41x
EC308940	10-C23	ED650968	12-61	ET302502	9-TR34,35	MI309414	3-13
EC308965	8-C62	EF258344	12-40	ET305463	10-TR9	ML311537	2-4
EC313520	10-C11	EF313489	12-44x	ET307349	10-TR2	ML313383	6-30
EC313532	9-C9,10	EF563670	12-42x	ET307349	10-TR4	MS302191	6-17
EC313532	9-C16,17	EF601964	12-38	ET310833	8-TR7,8	MT305793	3-19
EC313533	9-C28to31	EF602550	12-37	ET311868	10-TR1	MT312122	3-17
EC313533	9-C47	EF616555	12-41x	ET311868	10-TR3	MV269965	6-54
EC313536	9-C48	EF659711	12-43x	ET311868	10-TR5to7	MV309146	4-10
EC313781	9-C22	EF668474	12-39	ET311868	10-TR10	MZ313379	6-25
EC313781	9-C25	EI301463	8-IC1	ET311868	10-TR12	MZ313409	7-11
EC314986	8-C2	EI304165	9-IC3	ET311868	10-TR14	SA306240	12-58
EC405898	8-C3	EI304165	9-IC9	ET311868	10-TR16	SB313721	6-3
EC513990	8-C8	EI304165	9-IC11	ET311868	10-TR18	SB313722	6-5
EC516701	8-C69(K)	EI304166	9-IC2	ET311868	10-TR20	SB313723	6-7
EC516767	8-C67	EI304166	9-IC4	ET311868	10-TR22	SB313724	6-9
EC551160	10-C29	EI305237	9-IC7,8	ET311868	10-TR24	SB313725	6-11
ED249377	12-2	EI305237	9-IC10	ET311868	10-TR26	SB313782	6-10x
ED249377	12-62	EI305238	9-IC1	ET313514	10-TR8	SB313783	6-12x
ED303005	12-3	EI305238	9-IC6	ET313525	9-TR46,47	SB313784	6-6x
ED306109	10-D5	EI306141	8-IC2	ET313717	8-TR3	SB313785	6-8x
ED306109	10-D9	EI313694	9-IC5	ET313728	10-TR11	SB313786	6-4x
ED306109	10-D12,13	EI313694	9-IC12	ET313728	10-TR15	SE305651	13-8
ED306109	10-D15,16	EJ301513	12-31	ET313728	10-TR19	SE306936	13-9x
ED306109	10-D18,19	EJ304317	9-J902	ET313728	10-TR23	SE309648	13-4
ED306109	10-D21to23	EJ305629	8-J2	ET352146	8-TR1,2	SE310781	13-6
ED308945	10-D2	EJ305739	8-J1	ET399846	11-TR2,3	SE310782	13-7x
ED308952	8-D6	EJ306985	12-16	ET399846	11-TR5	SE313464	13-16
ED308952	8-D11,12	EL313491	6-29	ET554657	11-TR7	SE313465	13-17
ED308952	9-D7	EL313491	12-1	ET635220	9-TR10	SK305653	13-10
ED308952	9-D10to15	EL313491	12-15	ET635220	9-TR13	SK305654	13-13
ED308952	9-D21	EL313726	6-2	ET635220	9-TR16	SK305656	13-12x
ED308952	9-D23to25	EM313546	12-4	ET635220	9-TR23,24	SK305674	6-13
ED308952	9-D30,31	EO262484	8-L1	ET635220	9-TR26	SK305674	12-48
ED308952	9-D41,42	EO309363	8-FL3,4	ET638504	9-TR14	SK306130	6-15x
ED308952	9-D44	EO310831	8-T1	ET638504	9-TR17	SK306130	12-50x
ED308952	9-D56	EP313497	3-14	ET638504	9-TR25	SK308419	13-25
ED308952	9-D65	EP313498	7-1	ET638504	9-TR27	SK308491	13-27x
ED308952	9-D67to69	EP313498	12-12	ET638504	9-TR37,38	SK309299	13-22
ED308952	9-D72	EP313499	7-17	ET639437	8-TR4	SK309300	13-24x
ED308952	9-D74	EP313511	7-6	ET639437	8-TR6	SK311115	13-29x



### MB400

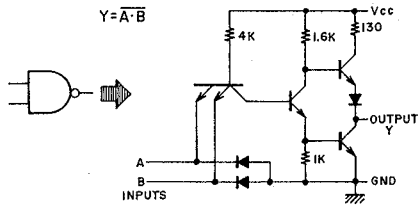
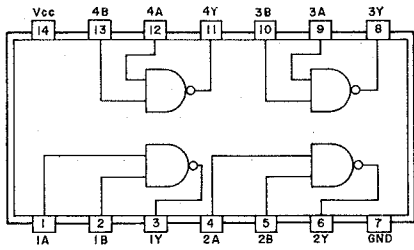

### MB401

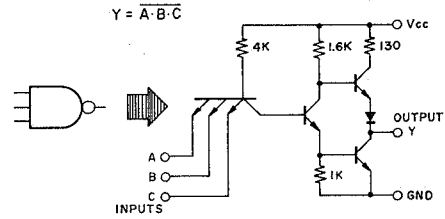
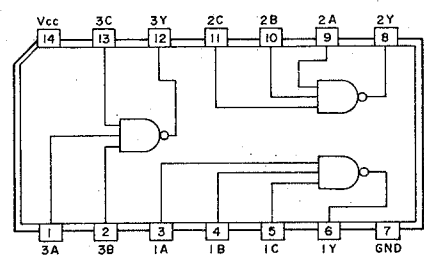

### MB402

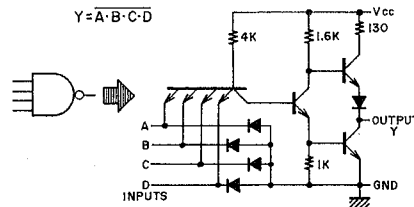
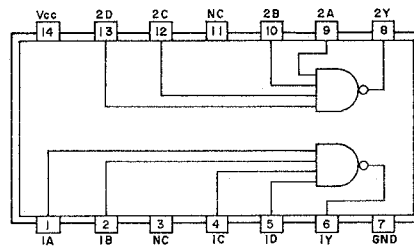

### MB417

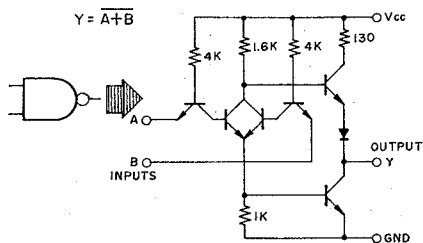
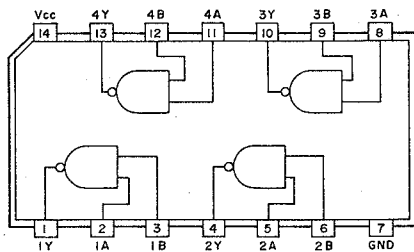

### MB418

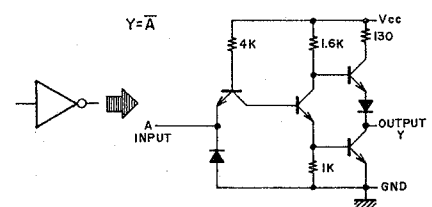
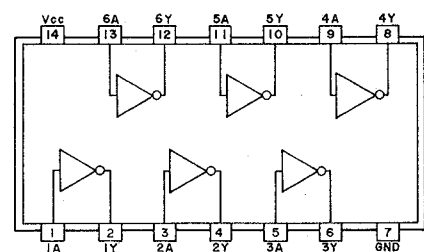

CR713B

