

SERVICE MANUAL

PARTS LIST

AT-2650
MODEL AM-2650

AKVA

ALSO APPLICABLE TO BLACK PANEL MODEL

SECTION 1

SERVICE MANUAL

TABLE OF CONTENTS

I.	TECHNICAL DATA	2
	1. MODEL AT-2650	2
	2. MODEL AM-2650	3
II.	DISMANTLING OF UNIT	4
	1. MODEL AT-2650	4
	2. MODEL AM-2650	5
III.	CONTROLS	6
	1. MODEL AT-2650	6
	2. MODEL AM-2650	7
IV.	PRINCIPAL PARTS LOCATION	8
	1. MODEL AT-2650	8
	2. MODEL AM-2650	9
V.	OPERATING PRINCIPLES OF QUADRATURE DETECTION SYSTEM	10
VI.	OPERATING PRINCIPLES OF PLL CIRCUIT EMPLOYED IN STEREO DEMODULATION CIRCUIT	12
	1. PLL CIRCUIT OPERATION	12
	2. STEREO DEMODULATION CIRCUIT	13
VII.	OPERATING PRINCIPLES OF FM NOISE CANCELLER CIRCUIT	15
	1. BASIC CIRCUIT FOR PULSE NOISE SUPPRESSION	15
	2. OPERATION PRINCIPLE WITH STEREO SIGNALS	15
	3. ADJUSTMENT METHOD FOR THE PILOT SIGNAL GENERATING CIRCUIT	16
VIII.	LEVEL DIAGRAM	17
IX.	TUNER ADJUSTMENT (AT-2650)	18
	1. FM TUNER SECTION ADJUSTMENT	19
	2. AM TUNER SECTION ADJUSTMENT	20
X.	AMPLIFIER ADJUSTMENT (AM-2650)	21
	1. IDLING CURRENT ADJUSTMENT	21
	2. LEVEL METER INDICATION ADJUSTMENT	22
XI.	TUNING CORD THREADING	23
XII.	CLASSIFICATION OF VARIOUS P.C BOARDS	24
	1. P.C BOARD TITLE AND IDENTIFICATION NUMBER	25
	2. MODEL AT-2650 COMPOSITION OF VARIOUS P.C BOARDS	28
	3. MODEL AM-2650 COMPOSITION OF VARIOUS P.C BOARDS	52

SCHEMATIC DIAGRAM

For basic adjustments, measuring methods, and operating principles, refer to GENERAL TECHNICAL MANUAL.

I. TECHNICAL DATA

1. MODEL AT-2650

FM TUNER SECTION

FREQUENCY RANGE	87.5 MHz to 108 MHz
SENSITIVITY (IHF)	1.6 μ V
CAPTURE RATIO	1.2 dB
SELECTIVITY (IHF)	More than 80 dB
IMAGE REJECTION	More than 110 dB (98 MHz)
IF REJECTION	More than 110 dB (98 MHz)
SPURIOUS REJECTION	More than 110 dB (98 MHz)
AM SUPPRESSION	55 dB
SIGNAL TO NOISE RATIO	75 dB
HARMONIC DISTORTION	MONO STEREO
	Less than 0.1% (100% modulation)
	Less than 0.15% (100% modulation)
FM STEREO FREQUENCY RESPONSE	20 Hz to 15 kHz +1 dB, -3 dB
MUTING	Level Control (1 μ V to 100 μ V)/Switchable to ON-OFF
STEREO SEPARATION	More than 45 dB (1 kHz)
SUB CARRIER SUPPRESSION	More than 65 dB
OUTPUT VOLTAGE	Controllable from 0 mV to 2V (100% modulation)
ANTENNA INPUT IMPEDANCE	300 ohms balanced, 75 ohms unbalanced

AM TUNER SECTION

FREQUENCY RANGE	520 kHz to 1,605 kHz
SENSITIVITY (IHF)	80 μ V/m (bar antenna), 13 μ V (external antenna)
SELECTIVITY (IHF)	More than 30 dB
IMAGE REJECTION	More than 80 dB (1,000 kHz)
IF REJECTION	More than 70 dB
SIGNAL TO NOISE RATIO	More than 50 dB
OUTPUT VOLTAGE	Controllable from 0 mV to 2V
ANTENNA	Built-in ferrite bar antenna

MISCELLANEOUS

SEMICONDUCTORS	Transistors: 12, Diodes: 15, FETs: 3, ICs: 5
POWER REQUIREMENTS	120V, 60 Hz for U.S.A. and Canada 220V, 50 Hz for Europe except UK and Australia 240V, 50 Hz for UK and Australia 110V/220V/240V, 50/60 Hz internally switchable for other countries.
DIMENSIONS	440 (W) x 144 (H) x 368 (D) mm, (17.3 x 5.7 x 14.5")
WEIGHT	7.5 kg (16.5 lbs)

* For improvement purposes, specifications and design are subject to change without notice.

2. MODEL AM-2650

POWER AMPLIFIER SECTION

RATED OUTPUT POWER 2-CHANNELS DRIVEN	65 watts per channel, minimum RMS, at 8 ohms from 20 to 20,000 Hz with no more than 0.08% total harmonic distortion
POWER BANDWIDTH (IHF)	6 Hz to 60 kHz / 8 ohms (Total Harmonic Distortion: 0.08%) 6 Hz to 60 kHz/8 ohms (Total Harmonic Distortion: 0.08%)
SIGNAL TO NOISE RATIO (IHF) PHONO AUX	Better than 75 dB Better than 95 dB
RESIDUAL NOISE	Less than 0.5 mV at 8 ohms
CHANNEL SEPARATION (IHF) PHONO	Better than 55 dB at 1,000 Hz
DAMPING FACTOR	More than 30 (1 kHz, 8 ohms)
OUTPUT SPEAKERS HEADPHONE	A, B (4 to 16 ohms)/A+B (8 to 16 ohms) 4 to 16 ohms

PREAMPLIFIER SECTION

INPUT SENSITIVITY/IMPEDANCE PHONO AUX TUNER TAPE MONITOR	PHONO 1: 3 mV/33/47/100 kohms PHONO 2: 3 mV/47 kohms 150 mV/100 kohms 150 mV/100 kohms PIN: 150 mV/100 kohms, DIN: 150 mV/100 kohms
OUTPUT LEVEL/IMPEDANCE TAPE REC	PIN: 150 mV/1 kohms, DIN: 30 mV/30 kohms
FREQUENCY RESPONSE PHONO (RIAA EQUALIZATION) TUNER, AUX, TAPE MONITOR	30 Hz to 15 kHz +1 dB, -1 dB 10 Hz to 60 kHz +1 dB, -1 dB
TONE CONTROL BASS TREBLE	±9 dB at 100 Hz ±9 dB at 10 kHz
LOUDNESS CONTROL	+10 dB at 100 Hz, +5 dB at 10 kHz (Volume control set at -30 dB position)
FILTER HIGH LOW	-3 dB at 10 kHz -3 dB at 30 Hz
AUDIO MUTE	-20 dB attenuation

MISCELLANEOUS

SEMICONDUCTORS	Transistors: 33, Diodes: 17, ICs: 4
POWER REQUIREMENTS	120V, 60 Hz for U.S.A. and Canada 220V, 50 Hz for Europe except UK and Australia 240V, 50 Hz for UK and Australia 110V/220V/240V, internally switchable, 50/60 Hz for other countries.
DIMENSIONS	440 (W) x 144 (H) x 345 (D) mm, (17.3 x 5.7 x 13.6")
WEIGHT	10.9 kg (23.5 lbs)

* For improvement purposes, specifications and design are subject to change without notice.

II. DISMANTLING OF UNIT

1. MODEL AT-2650

In case of trouble, etc. necessitating dismantling, please dismantle in the order shown in the photographs. Reassemble in reverse order.

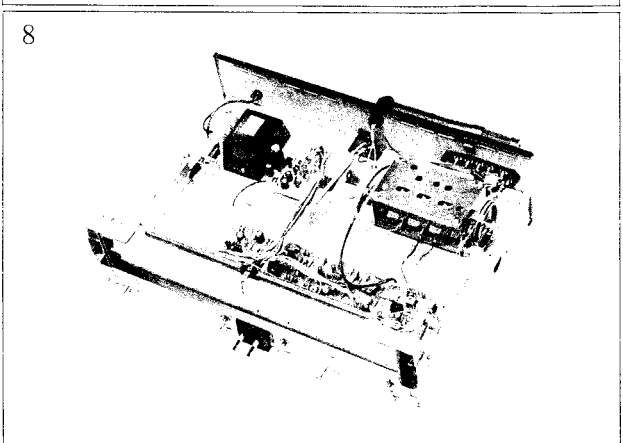
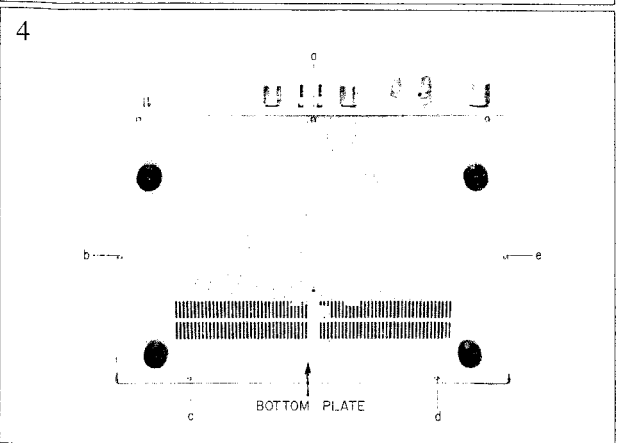
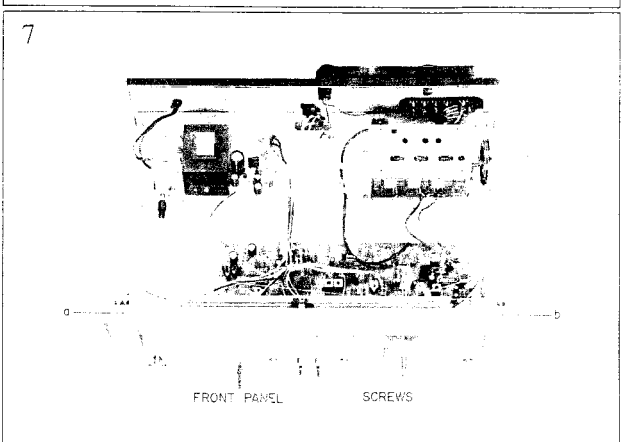
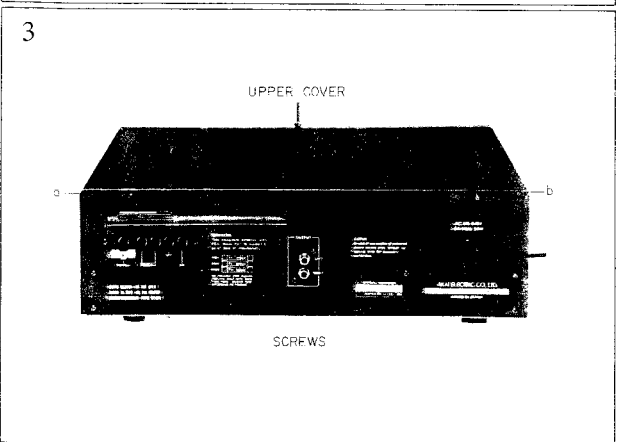
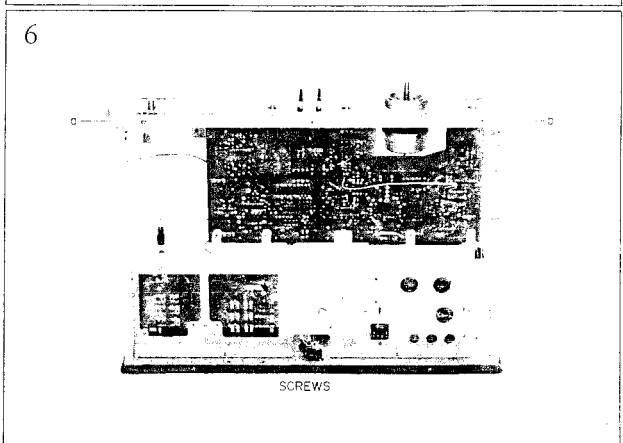
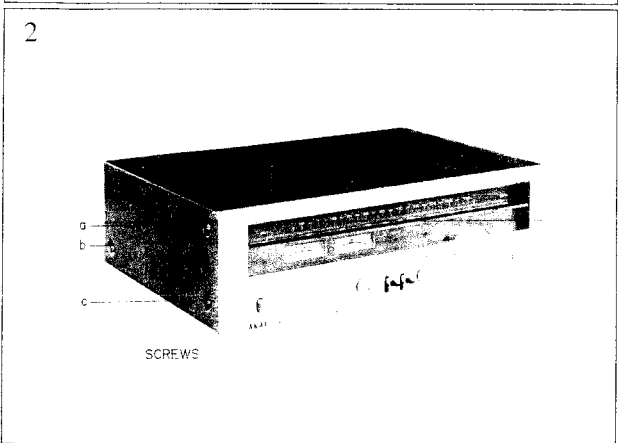
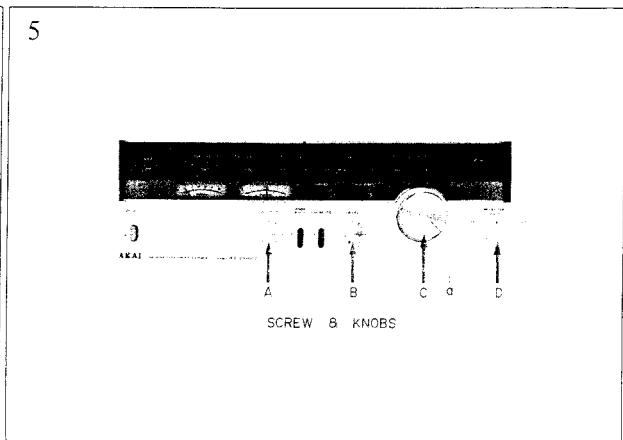
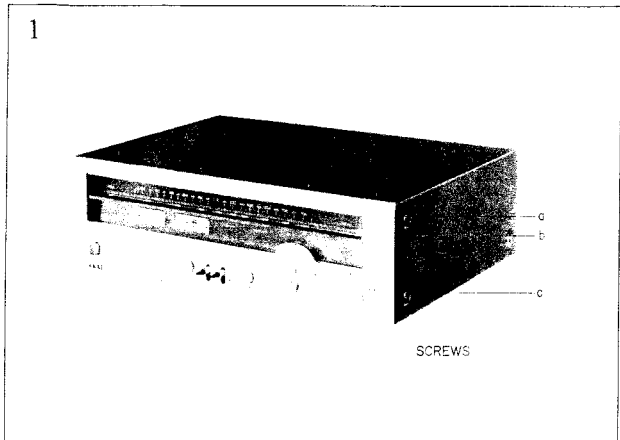

2. MODEL AM-2650

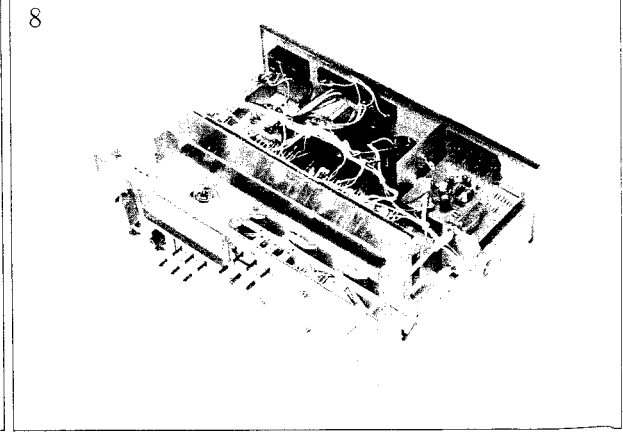
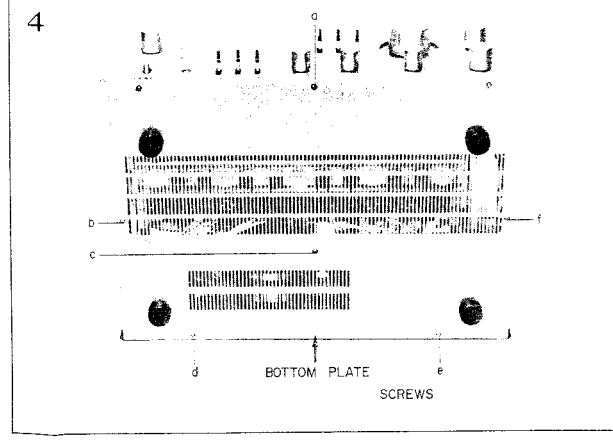
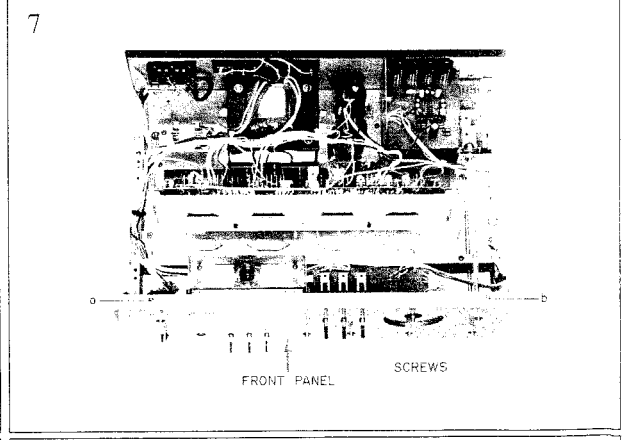
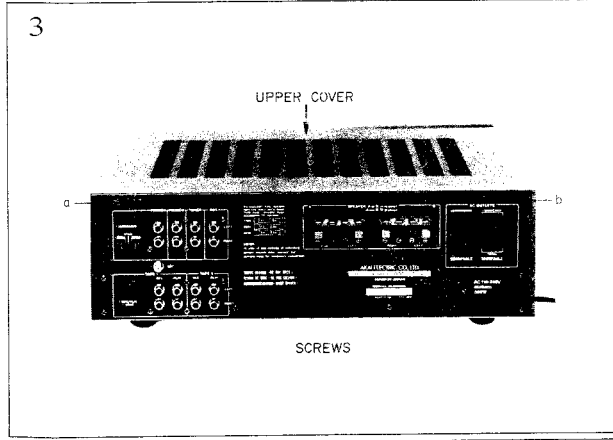
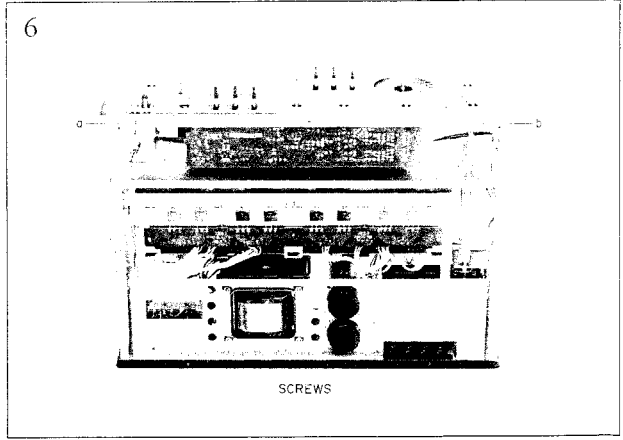
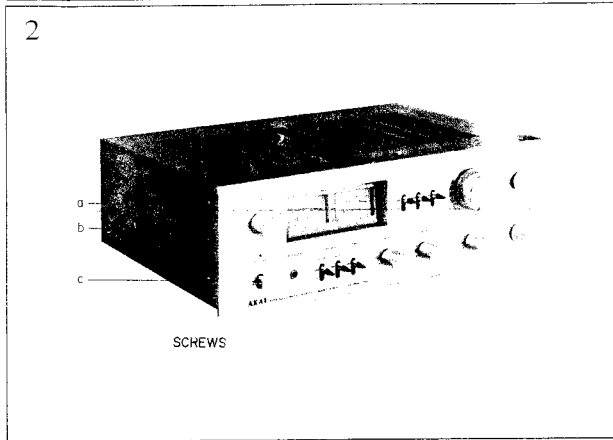
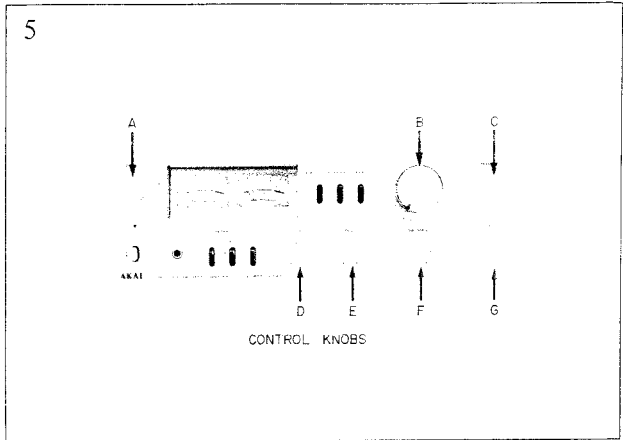
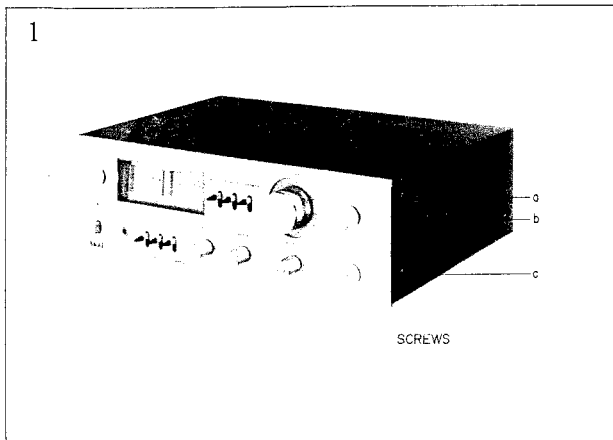

III. CONTROLS

1. MODEL AT-2650

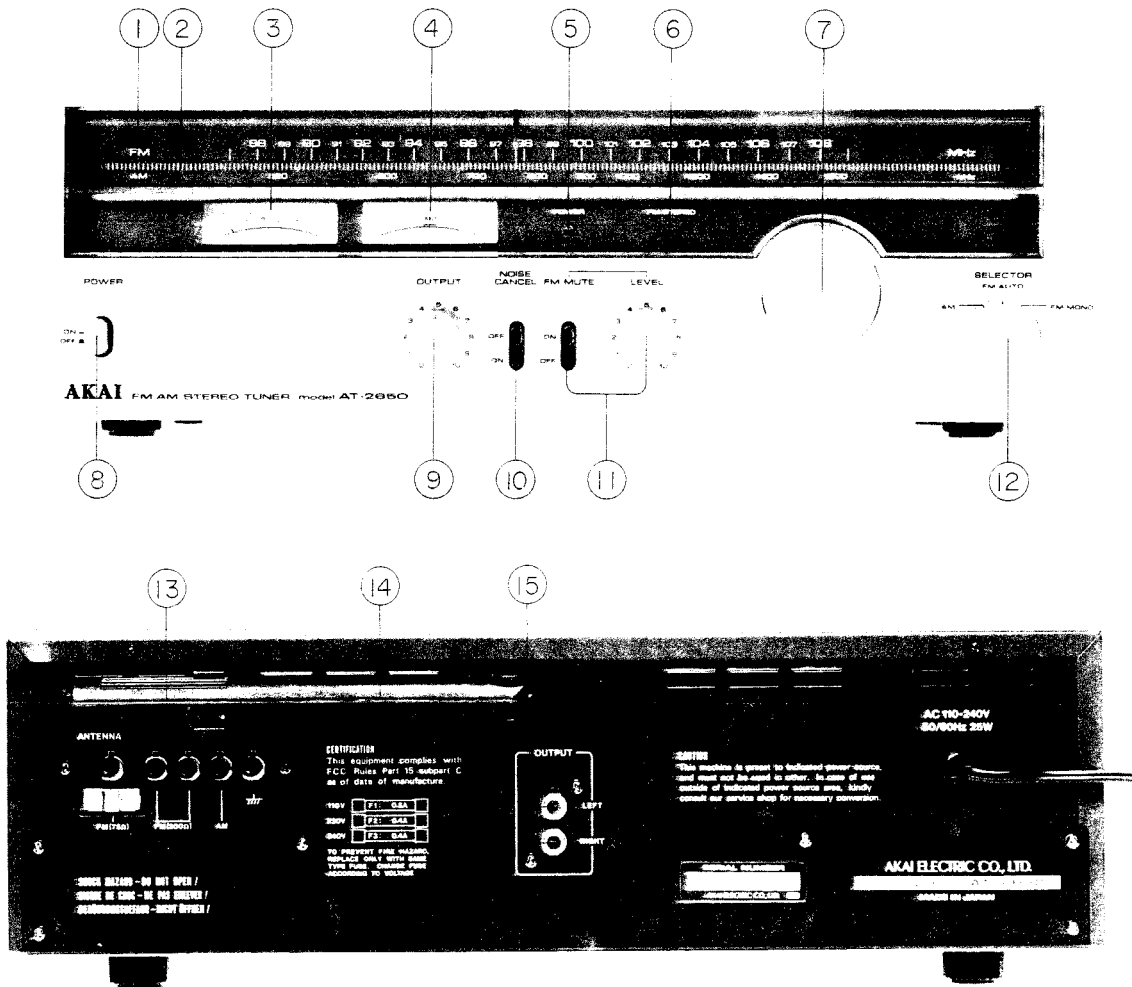

Fig. 1 Controls AT-2650

1. FM DIAL SCALE
2. AM DIAL SCALE
3. SIGNAL STRENGTH METER
4. FM TUNING METER
5. POWER INDICATOR LAMP
6. FM STEREO INDICATOR LAMP
7. TUNING KNOB
8. POWER SWITCH
9. OUTPUT LEVEL CONTROL
10. NOISE CANCEL SWITCH
11. FM MUTE SWITCH and LEVEL ADJUSTER
12. INPUT SELECTOR
13. ANTENNA TERMINALS
14. AM FERRITE BAR ANTENNA
15. OUTPUT TERMINALS

2. MODEL AM-2650

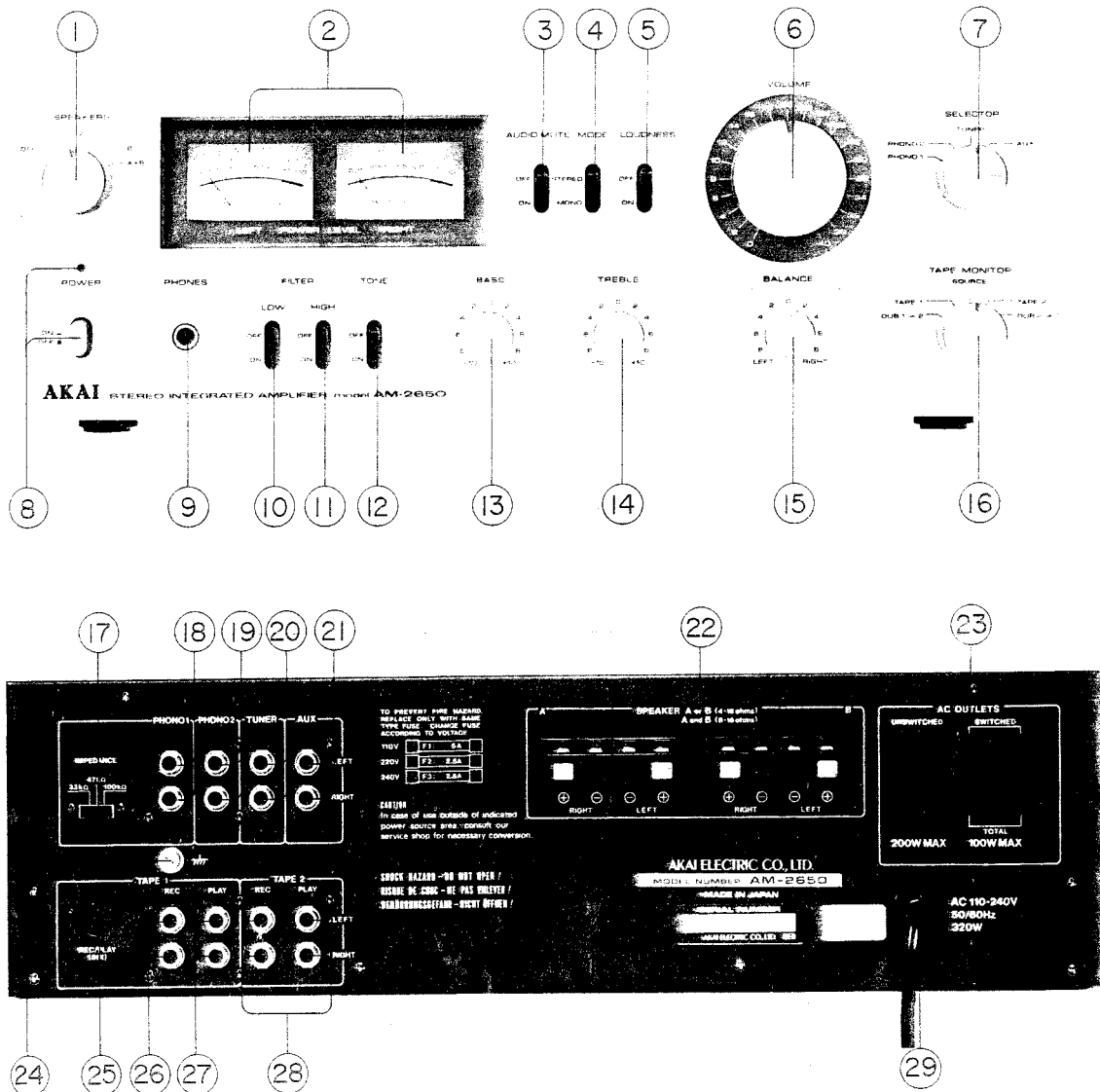

Fig. 2 Controls AM-2650

1. SPEAKER SYSTEM SELECTOR
2. OUTPUT POWER LEVEL METERS (Left and Right)
3. AUDIO MUTE SWITCH
4. MODE SWITCH
5. LOUDNESS SWITCH
6. VOLUME CONTROL
7. INPUT SELECTOR
8. POWER SWITCH and POWER INDICATOR LAMP
9. HEADPHONE JACK
10. LOW FILTER SWITCH
11. HIGH FILTER SWITCH
12. TONE SWITCH
13. BASS TONE CONTROL
14. TREBLE TONE CONTROL
15. STEREO BALANCE CONTROL
16. TAPE MONITOR SWITCH
17. IMPEDANCE SWITCH
18. PHONO 1 TERMINALS
19. PHONO 2 TERMINALS
20. TUNER TERMINALS
21. AUX TERMINALS
22. A and B SYSTEM SPEAKER TERMINALS
23. EXTRA AC OUTLETS (some models not equipped with this facility)
24. GROUND TERMINAL
25. TAPE 1 SYSTEM DIN JACK
26. TAPE 1 SYSTEM REC JACKS
27. TAPE 1 SYSTEM PLAY JACKS
28. TAPE 2 SYSTEM REC/PLAY JACKS
29. AC CORD (AC Inlet for UK and some other countries)

IV. PRINCIPAL PARTS LOCATION

1. MODEL AT-2650

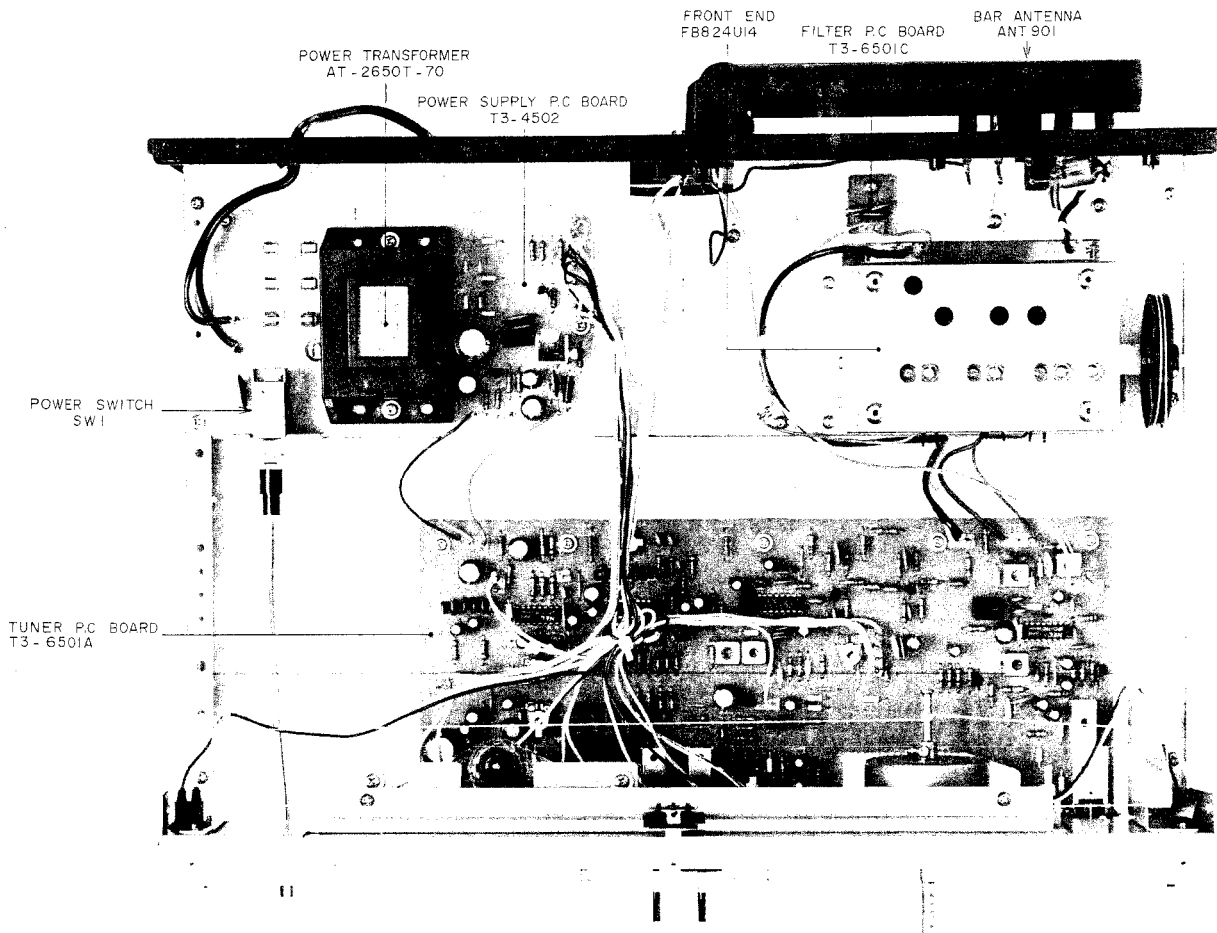

Fig. 3 Top View

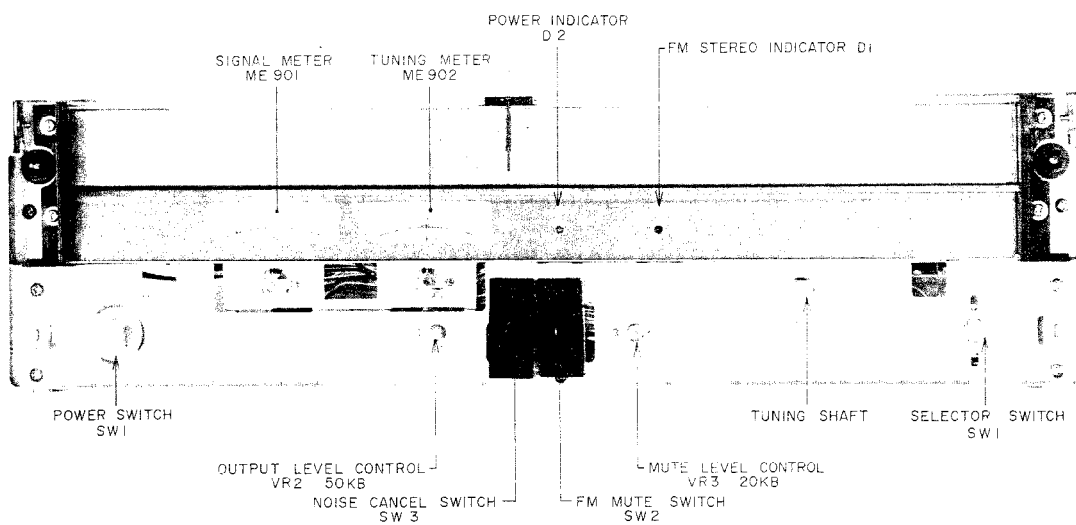

Fig. 4 Front View

2. MODEL AM-2650

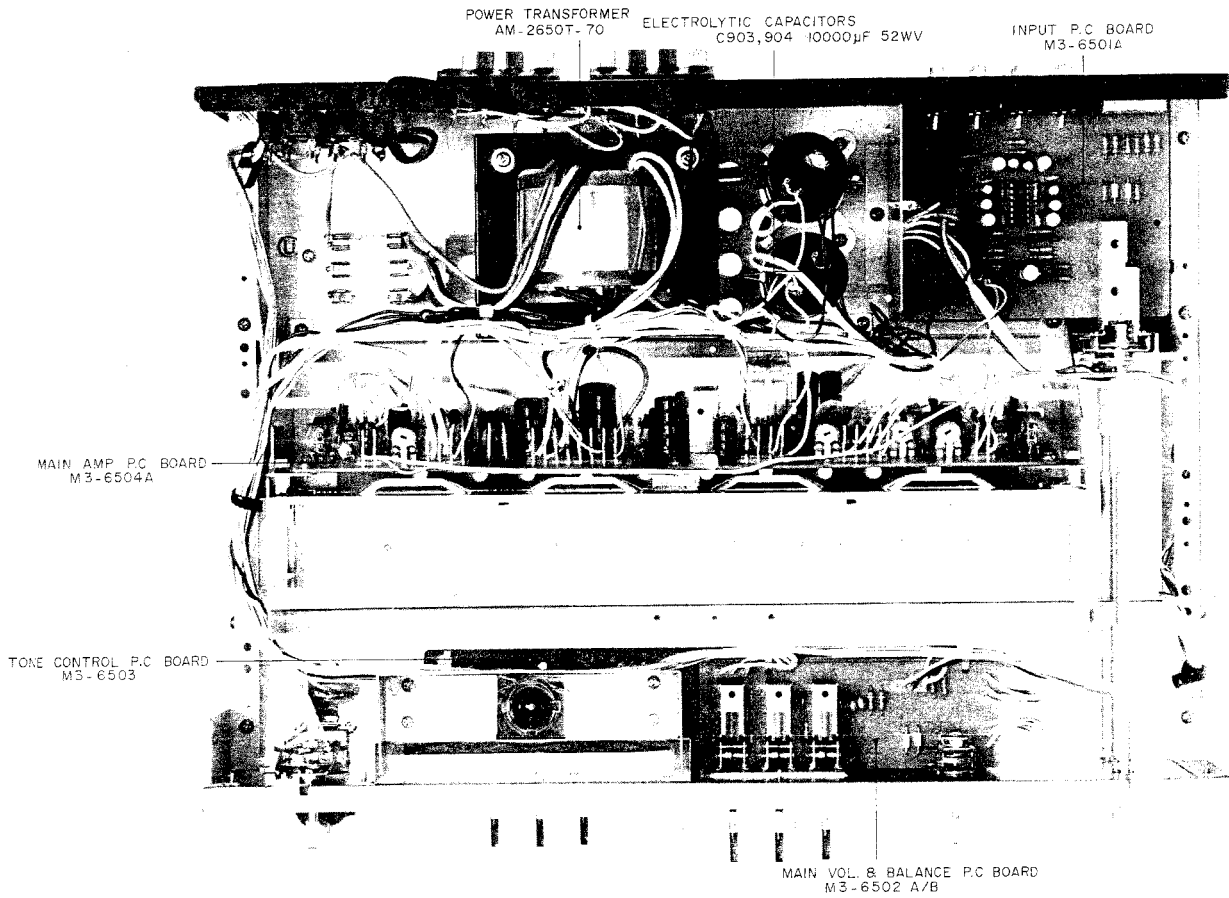

Fig. 5 Top View

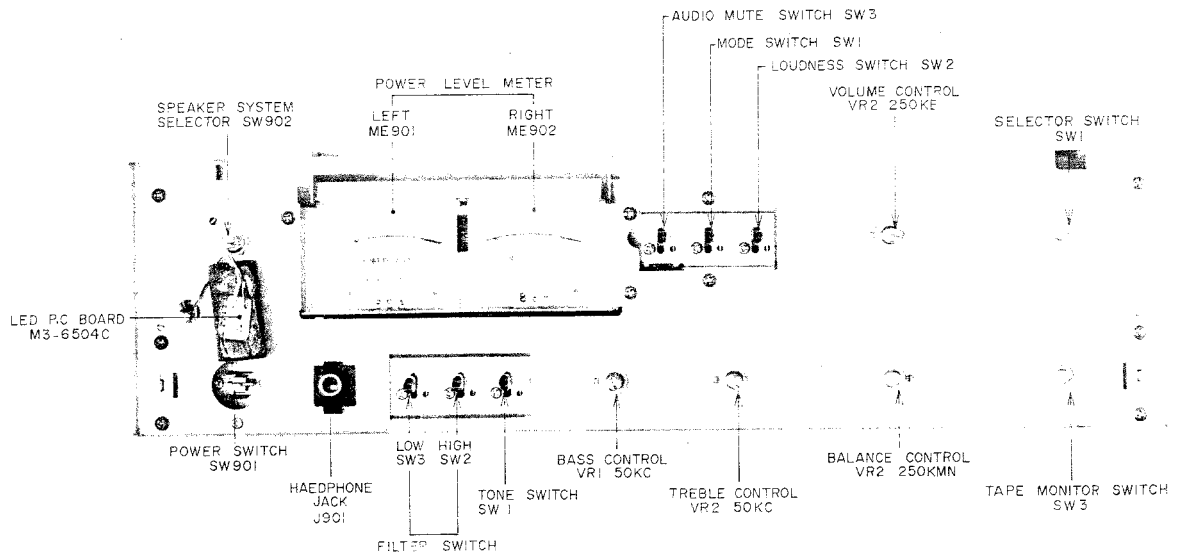

Fig. 6 Front View

V. OPERATING PRINCIPLES OF QUADRATURE DETECTION SYSTEM

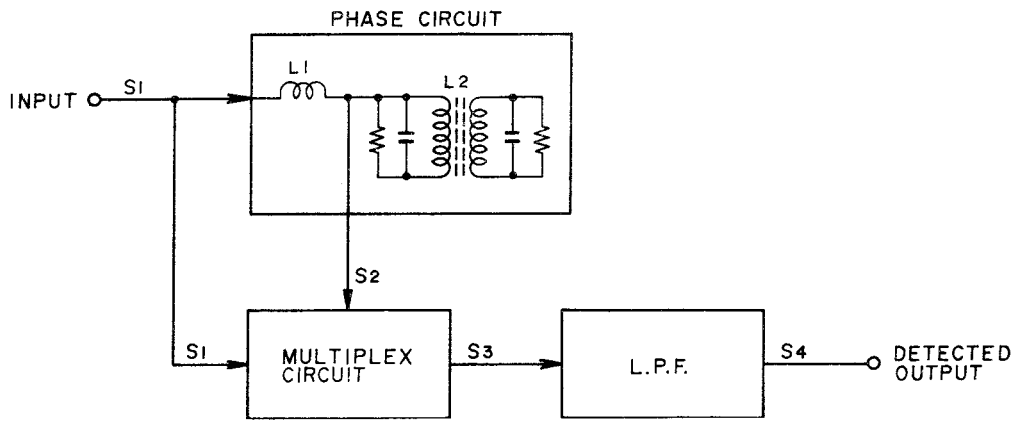

Fig. 7 Quadrature Detection Block Diagram

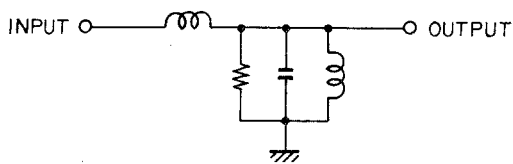

Fig. 8 Single Tuning Type

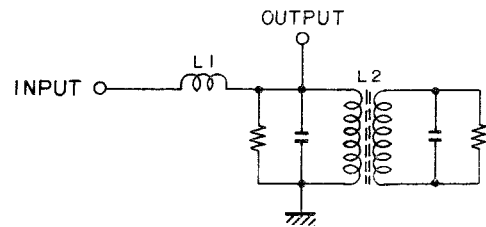

Fig. 9 Double Tuning Type

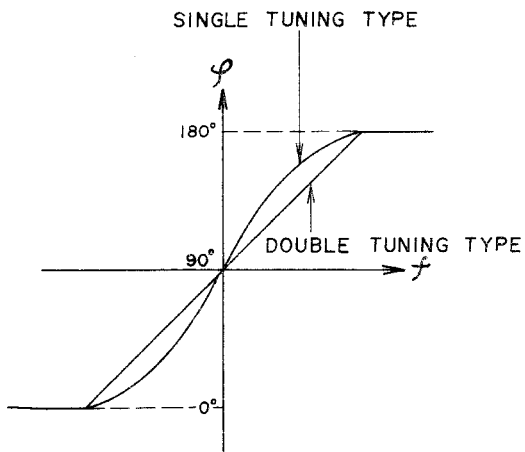

Fig. 10 Tuning Curve

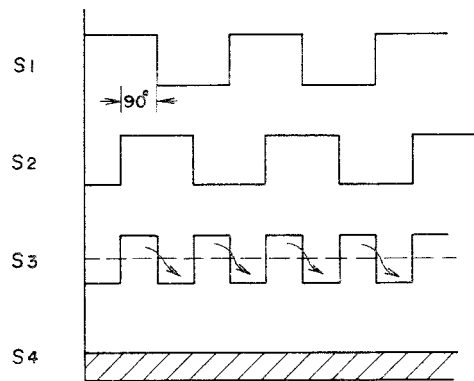

Fig. 11 Output at Non-modulation

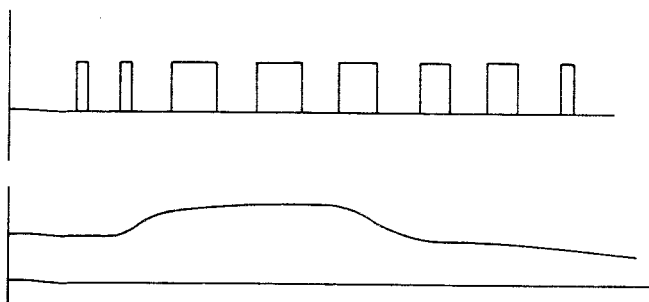

Fig. 12 Output at Modulation Time

The Quadrature Detection Circuit is comprised of a Phase Circuit, a Multiplier Circuit and a Low Pass Filter (L.P.F.) as shown in Fig. 7.

There are two types of Phase Circuits, the Single tuning type shown in Fig. 8 and the Double tuning type shown in Fig. 9. However, because with the double tuning type there is less frequency deviation in relation to carrier frequency, linearity is improved as shown in Fig. 10 and phase distortion is reduced, this type of phase circuit is employed in the AT-2650.

Input signal S1 is divided into the part which enters the direct multiplier circuit and the part which passes the phase circuit and enters the multiplier circuit. The signal supplied to the phase circuit is always 90° phase delayed at L1. Also because at Non-modulation time, L2 is tuned to 10.7 MHz, if modulation is applied and S1 is changed from 10.7 MHz, phase deviation at L2 will take place proportionately in relation to this changed part and this becomes S2 signal which is delayed in relation to S1.

At Non-modulation, because as shown in Fig. 11, the input signal S1 and 90° phase delayed (by means of L1) signal S2 are switched by means of the multiplier circuit, the output signal becomes S3.

Because this S3 passes the low pass filter and becomes S4 fixed direct current, the detector output is zero. Then, when modulation is applied, because the switched output is varied according to the degree of modulation, and the output which passed the low pass filter becomes the pulsating current part as shown in Fig. 12, detector output is obtained.

VI. OPERATING PRINCIPLES OF PLL CIRCUIT EMPLOYED IN STEREO DEMODULATION CIRCUIT

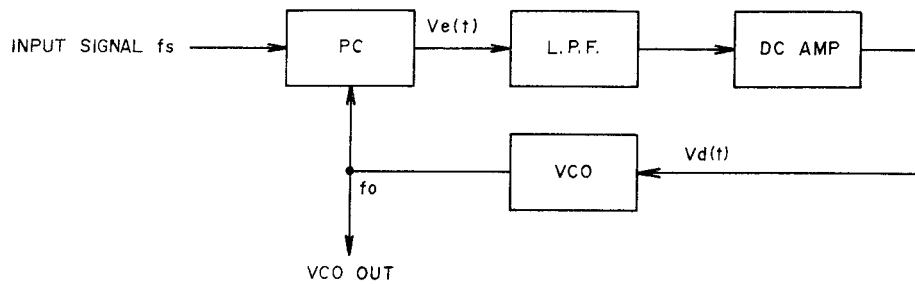

Fig. 13 PLL Circuit

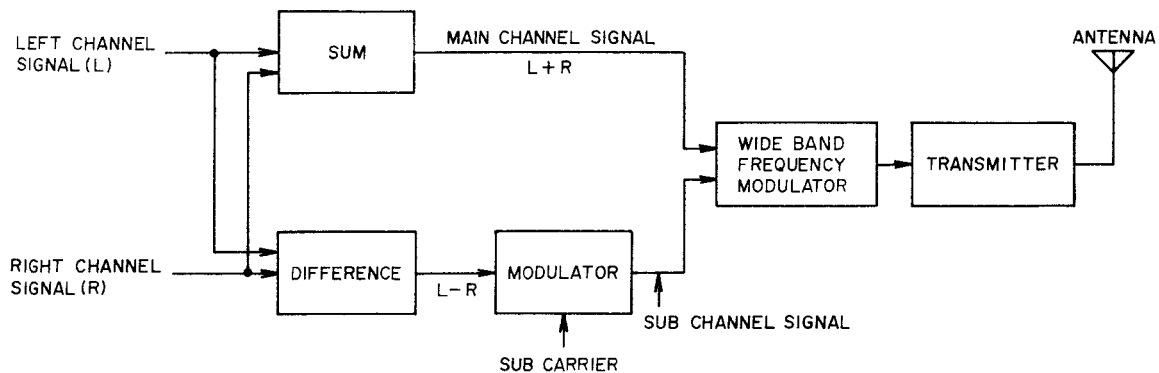

Fig. 14 FM Broadcasting System Diagram

To separate the FM stereo broadcast signal received to date into left and right signals, a 19 kHz pilot signal was successively multiplied to form a 38 kHz signal and stereo separation was effected from this. However, with this multiplier system, change in coils due to wear occurred and adjustment points were numerous, etc. Therefore, this model employs a newly developed PLL circuit which produces an exceedingly accurate 38 kHz switching signal.

1. PLL CIRCUIT OPERATION

PLL circuit is a kind of feedback circuit and is comprised of a Phase Comparator (PC), a Low Pass Filter (LPF), a Direct Current Amplifier (DC Amp) and a Voltage Control Oscillator (VCO) as shown in Fig. 13. The PC compares input signal F_s and VCO oscillator output and generates the difference in signal voltage $V_e(t)$ proportionately to this phase deviation. This $V_e(t)$ passes LPF and the DC Amp and becomes control voltage. This control voltage supplied to VCO and VCO oscillation frequency is DC controlled. When there is no input signal F_s , because there is also no $V_e(t)$, control voltage $V_d(t)$ becomes zero, and VCO maintains a *Free-running oscillation frequency. When a signal enters, VCO oscillation frequency F_o is controlled to narrow the difference between F_s by means of feedback as described above, and the PLL circuit assumes a synchronous condition. This is referred to as input signal lock. (When the difference between F_o and F_s is too large, the differential signal frequency becomes

high and is reduced at the LPF. However, because the VCO control voltage does not change, PLL will not stay within the *lock range).

Because of the ability of the signal interference removing LPF to accumulate the previous voltage when the PLL deviates from within the lock range due to certain interference, the original condition is quickly reinstated.

* Free running frequency: Oscillating frequency when there is no input signal.

* Lock range: At the condition in which the VCO oscillation frequency is locked to the input signal, the lock range is the oscillating frequency in which when the input signal changes, the PLL maintains its input signal lock condition.

Accordingly, in case F_s is changed inside the PLL lock range, VCO oscillation frequency always follows this, and a no frequency deviation and no phase difference signal is obtained. In other words, VCO oscillation frequency can be locked to F_s .

2. STEREO DEMODULATION CIRCUIT

As shown in Fig. 14 for FM broadcasts, the sum signal (L+R) consists of left signal (L) and right signal (R) and the audio frequency band of this signal in its original form is frequency modulated.

On the other hand, the difference signal of both (L-R) is changed to high frequency through the use of the sub carrier, and is referred to as the sub channel signal. The carrier is further frequency modulated and sent to the FM stereo transmitter.

Accordingly, for composite stereo signal demodulation, the sub carrier used for demodulation at the transmitter must be the same uniform 38 kHz signal as the frequency and phase. If the 38 kHz waveform is asymmetrical, channel separation will become poor. At the PLL employed MPX stereo demodulator circuit, as shown in Fig. 13 first a 76 kHz signal is oscillated and when this passes the divider, a symmetrical 38 kHz signal is obtained.

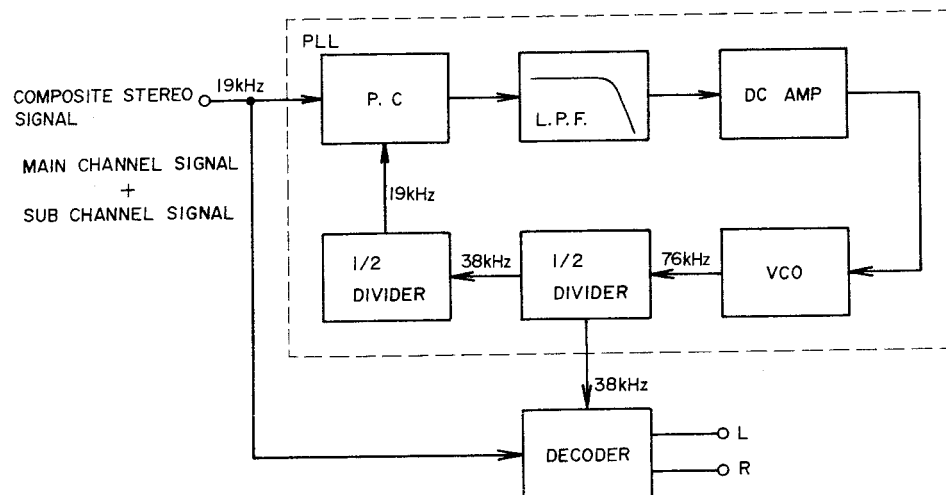

Fig. 15 MPX IC Function

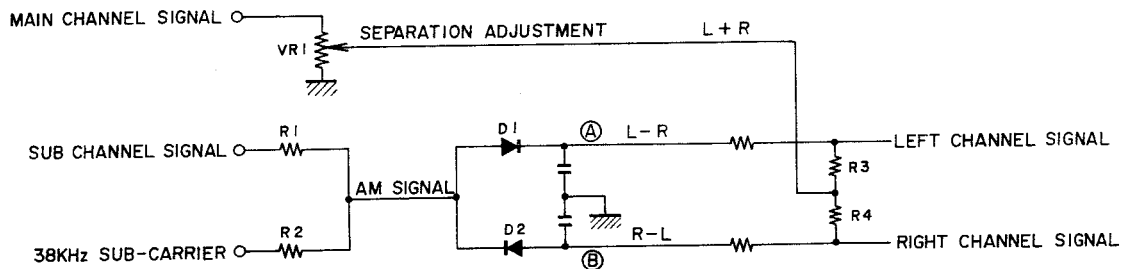

Fig. 16 Multiplex Decoder

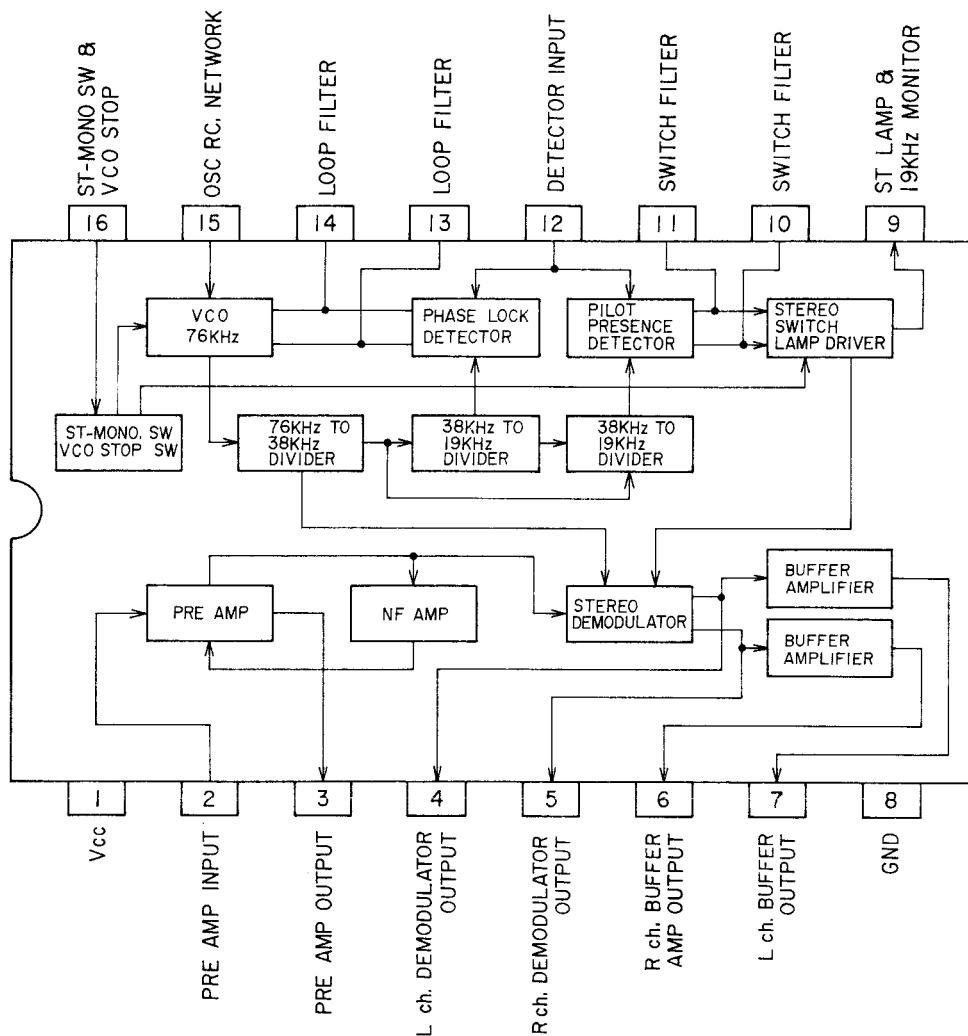

Fig. 17 μ PC1173C Block Diagram

This 38 kHz sub carrier is supplied to the multiplex decoder together with the sub channel of the composite stereo signal. At the multiplex decoder, left and right channel audio signals are separated in order as shown in Fig. 16.

The 38 kHz sub carrier composited with the sub channel signal of which the carrier part was removed when sub channel signal and sub carrier passed R1, R2 produces the regular AM wave. Then, because this envelop is detected by mutually reverse polarity connected diodes D1 and D2, L-R signal is emitted at point \textcircled{A} and R-L signal at point \textcircled{B} .

Also, because the main channel signal (L+R) is supplied to R3, R4 center point, \textcircled{A} \textcircled{B} point voltage is added and subtracted and becomes

$$(L+R) + (L-R) = 2L \text{ (left channel)}$$

$$(L+R) + (R-L) = 2R \text{ (right channel)}$$

The level of the main channel signal (L+R) can be adjusted by means of the variable resistor VR (VR1) for optimum separation.

However, please refer to Fig. 17 for the Block Diagram of PLL IC μ PC1173C used in the model AT-2650.

VII. OPERATING PRINCIPLES OF FM NOISE CANCELLER CIRCUIT

IC LA2100 used in this model is a monolithic IC for FM noise canceller use. Situated between the FM detector and the stereo demodulator, this circuit features effective elimination of pulsive external noise such as engine noise.

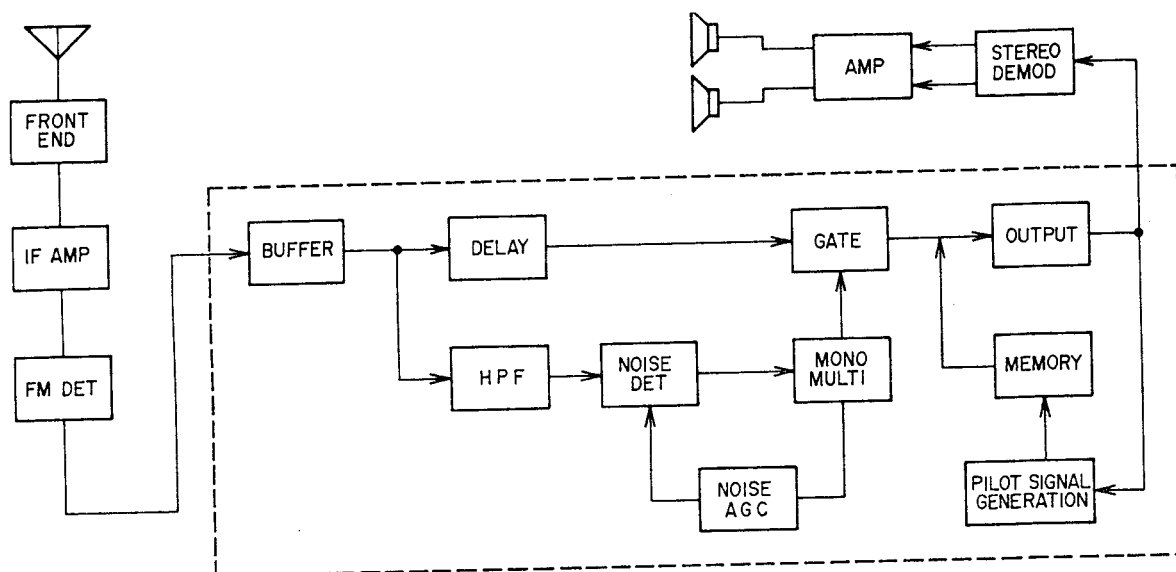

Fig. 18 Function Structure LA2100

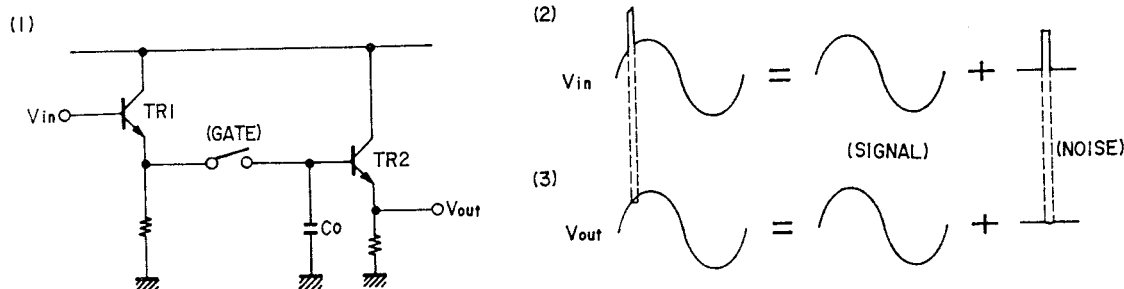

Fig. 19 Basic circuit for pulse noise suppression and wave forms

1. BASIC CIRCUIT FOR PULSE NOISE SUPPRESSION

The composition of LA2100 is made up of a gate circuit and a holding condenser to eliminate pulse noise.

When the gate is closed as in Fig. 19(1), condenser C_0 is driven by a low impedance (emitter follower TR1) and therefore the output signal is the same as the V_{in} input.

When pulse noise enters, the gate opens immediately, and condenser C_0 maintains the signal level prior to noise input. When the noise stops, the gate closes and the wave form returns to normal. The output wave form V_{out} becomes similar to the wave form of Fig. 19(3). In terms of noise alone, it means that the noise (2) is suppressed as in (3).

2. OPERATION PRINCIPLE WITH STEREO SIGNALS

When the aforementioned circuit is used on the stereo signals, the pilot signal is cut out while the gate is open and distorts the stereo composite signal to generate irritating noise. To prevent this distortion, during the time gate is open a 19 kHz sine wave of the same amplitude and phase as that of the pilot signal is generated from the pilot signal generating circuit (19 kHz sine wave generating circuit). This is added to the holding condenser Fig. 19(1) electric potential while the gate is open and compensates the pilot signal.

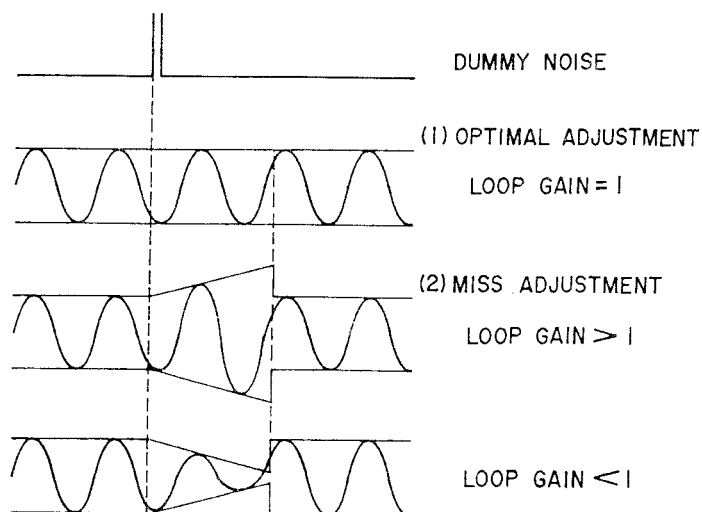

Fig. 20 Pilot signal generating circuit adjustment and pin wave form (non-modulated stereo signal)

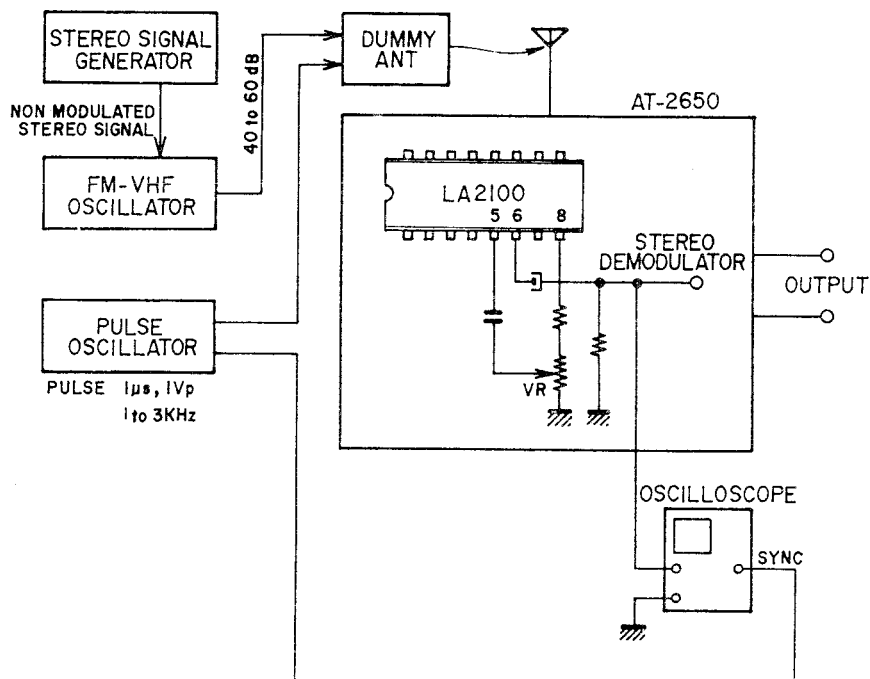

Fig. 21 Pilot signal generating circuit adjustment method

3. ADJUSTMENT METHOD FOR THE PILOT SIGNAL GENERATING CIRCUIT

(Refer to Figs. 20, 21 and 23)

To compensate the pilot signal, the 19 kHz sine wave amplitude must be equal to the amplitude before the gate is opened. To do this, set the loop gain of the pilot signal generating circuit to 1 with the adjustment volume as in Fig. 20 (1).

Actual adjustment involves the following: make con-

nections as in Fig. 21 and switch the noise cancel switch on. Oscillate non modulated stereo signal and pulse, and observe the wave forms on the oscilloscope. Next, adjust the adjustment volume VR5 5 kΩ so that the amplitude at the gate is equal to the amplitude before and after.

Although the adjustment can be made as above, it has been fully adjusted at the factory and should not need readjustment unless it has been touched otherwise.

VIII. LEVEL DIAGRAM

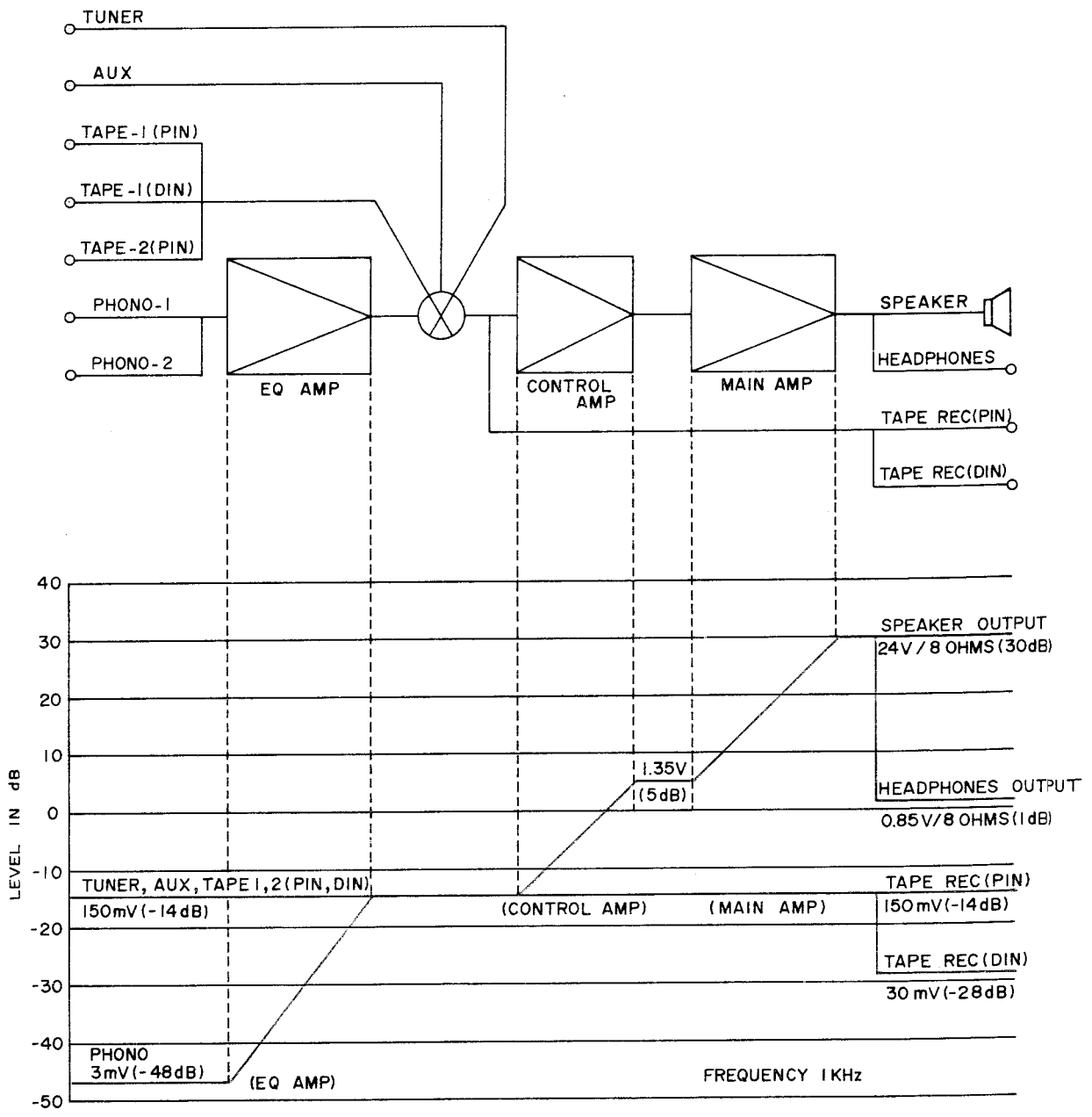

Fig. 22 Level Diagram AM-2650

IX. TUNER ADJUSTMENT (AT-2650)

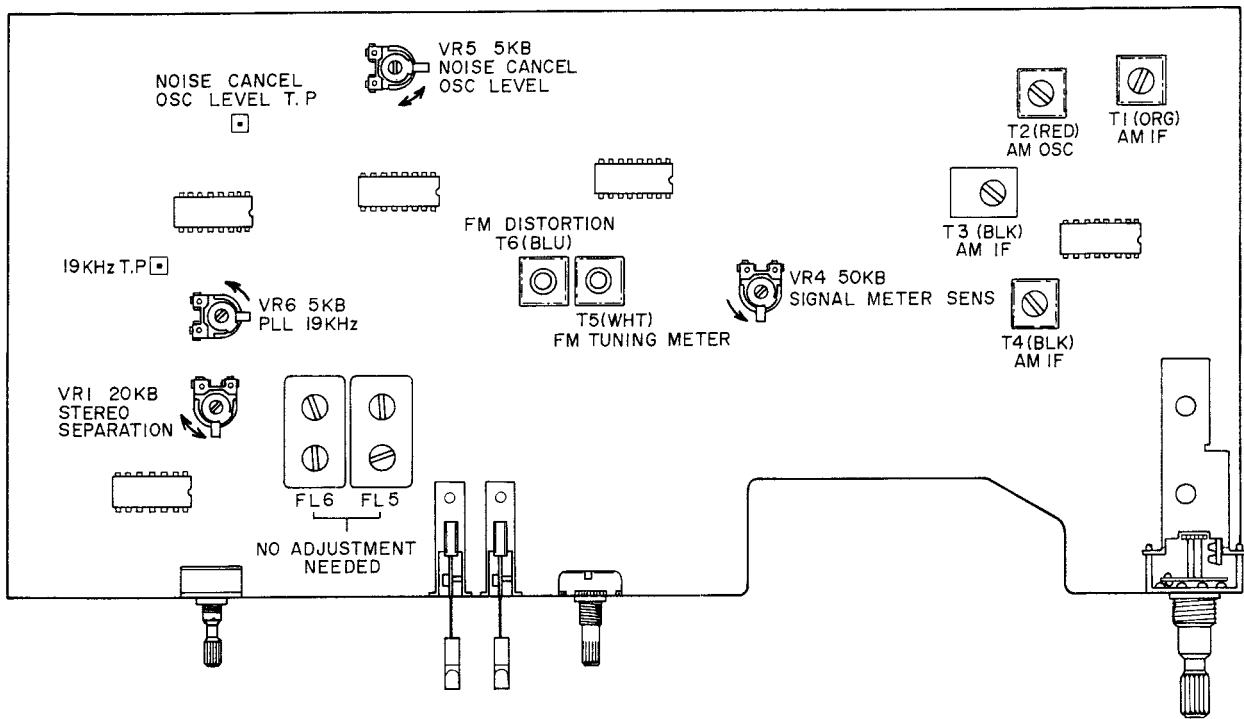

Fig. 23 Tuner P.C Board T3-6501A

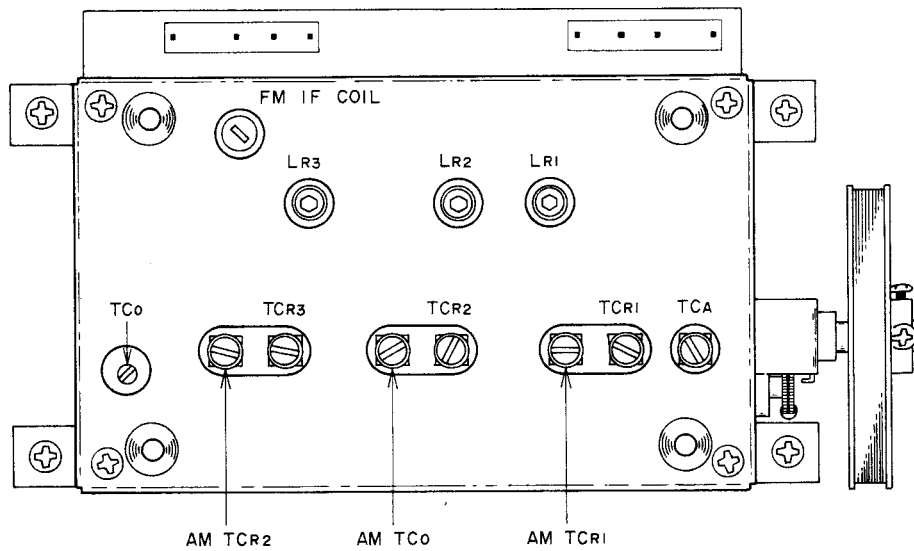

Fig. 24 Front End FB824U14

1. FM TUNER SECTION ADJUSTMENT (Refer to Figs. 23, 24)

Step	Adjustment Item	Adjustment Point	Result	Remarks
1	Front End IF Coil	IF Coil (Front End)	Maximum Noise Level	SELECTOR to FM MONO. FM MUTE and NOISE CANCEL to OFF. Tune only noise without interference of broadcasting.
2	Tuning Meter Centering	T5 (WHT) (Tuner P.C Board)	Centered Tuning Meter Indication	Same as above.
3	Distortion Factor	T6 (BLU) (Tuner P.C Board)	Less than 0.1% Distortion Factor	98 MHz, 60 dB (mono) input. Less than 0.1% on both channels See NOTE 1.
4	Confirmation of Tuning Meter Indication			If Tuning Meter Indication is not centered re-adjust Step 2 and 3 above.
5	High Range Scale Indication	TCo (Front End)	Maximum Output	108 MHz, 60 dB (mono) input. TUNING INDICATOR to 108 MHz. Error: Within ± 250 kHz.
6	Confirmation of Low Range Scale Indication		Maximum Output	88 MHz, 60 dB (mono) input. TUNING INDICATOR to 88 MHz. Error: Within ± 250 kHz.
7	High Range Sensitivity	TCA, TCR1, TCR2, TCR3 (Front End)	Less than 3% Distortion Factor	108 MHz, Less than 4 dB(mono) input.
8	Low Range Sensitivity	LR1, LR2, LR3 (Front End)	Less than 3% Distortion Factor	98 MHz, Less than 3 dB(mono) input. See NOTE 2.
9	Confirmation of Mid Range Sensitivity		Less than 3% Distortion Factor	98 MHz, Less than 4 dB(mono) input. See NOTE 2.
10	PLL Free Running Frequency	VR6 5 kB (Tuner P.C Board)	19.00 kHz	FM SELECTOR to FM AUTO. FM MUTE to ON. Connect frequency counter to Test Point. See NOTE 3.
11	Confirmation of Stereo Indicator Lighting			98 MHz. 60 dB (stereo) input. Unlet stereo indicator indicates no stereo separation.
12	Stereo Separation (Left→Right)	VR1 20 kB (Tuner P.C Board)	More than 45 dB	FM MUTE to OFF. 98 MHz, 60 dB (stereo), Lch input Minimum output of R ch.
13	Stereo Separation (Right→Left)	VR1 20 kB (Tuner P.C Board)	More than 45 dB	98 MHz, 60 dB (stereo), Rch input Minimum output of L ch
14	Signal Meter Sensitivity	VR4 50 kB (Tuner P.C Board)	Indicator at "4.5"	98 MHz, 100 dB (mono) input

Car t-1

- NOTES: 1. When the distortion factor is not less than 0.1% in Step 3 adjust by turning the Front End IF C oil core but not more than 1/2 turn.
2. In the event that distortion factor in Step 9 is not less than 3%, re-adjust step 7 & 8 obtain 3% distortion factor.
3. PLL IC free running frequency must be an exact 19.00 kHz.

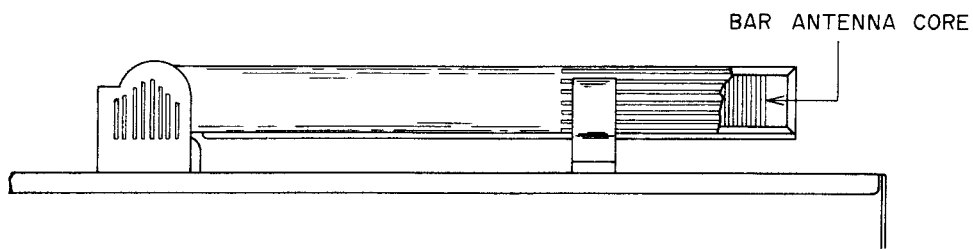

Fig. 25 Bar Antenna

2. AM TUNER SECTION ADJUSTMENT (Refer to Figs. 23, 24 and 25)

Step	Adjustment Item	Adjustment Point	Result	Remarks
1	Low Range Scale Indication	T2 (RED) (Tuner P.C Board)	Maximum Output	SELECTOR to AM. 520 kHz 50 dB input. TUNING INDICATOR to 520 kHz. Error: Within 2%
2	High Range Scale Indication	AM TCo (Front End)	Maximum Output	1,400 kHz 50 dB input. TUNING INDICATOR to 1,400 kHz Error: Within 2%
3	Low Range Sensitivity	Bar Antenna core T1 (ORG) T3, T4 (BLK) (Tuner P.C Board)	Maximum Output Minimum Distortion Factor	520 kHz 50 dB input. Less than 10% Distortion Factor.
4	High Range Sensitivity	AM TCR1 AM TCR2 (Front End)	Maximum Output Minimum Distortion Factor	1,400 kHz 50 dB input. Less than 10% Distortion Factor.

Chart-2

NOTE: For best results, repeat Steps 1 through 4 two or three times.

X. AMPLIFIER ADJUSTMENT (AM-2650)

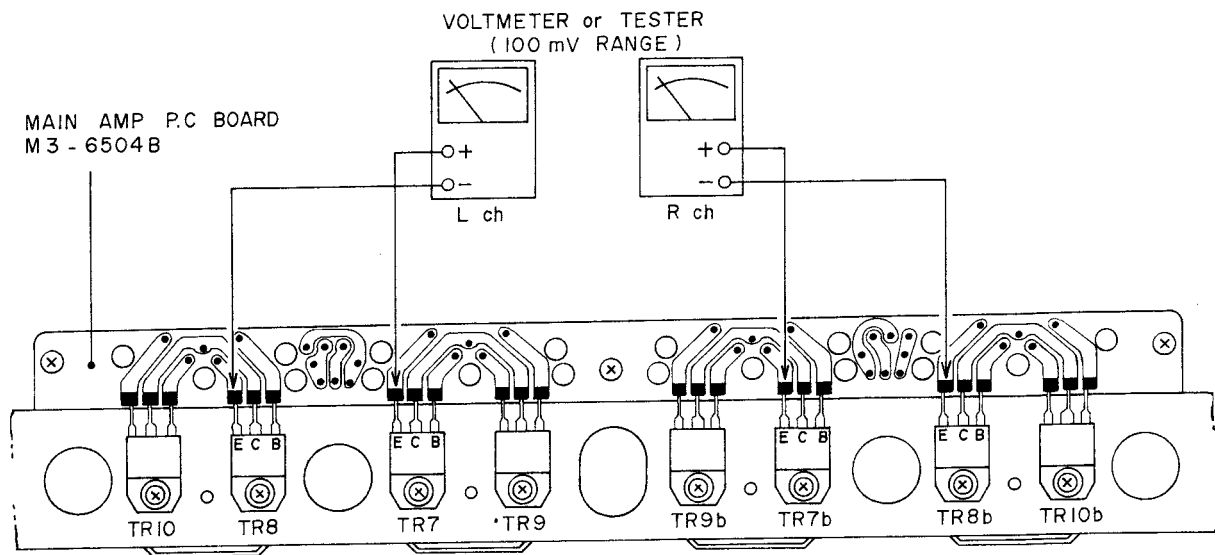

Fig. 26 Instrument Connection

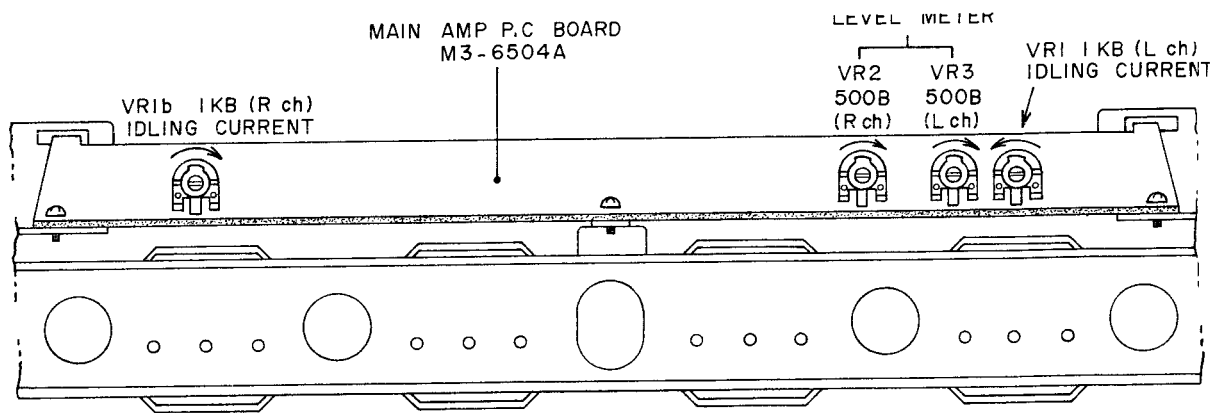

Fig. 27 Adjustment Points

1. IDLING CURRENT ADJUSTMENT (Refer to Figs. 26, 27)

Step	Adjustment Item	Adjustment Point	Result	Remarks
1	Idling Current (Left Channel)	VR1 1 k Ω (Main Amp P.C Board)	15 mV ± 5 mV	Use a Voltmeter or Tester with DC 100mV range. (Idling Current is 30 mV ± 10 mV)
2	Idling Current (Right Channel)	VR1b 1 k Ω (Main Amp P.C Board)	15 mV ± 5 mV	

Chart-3

* Be careful not to damage the Power Transistors.

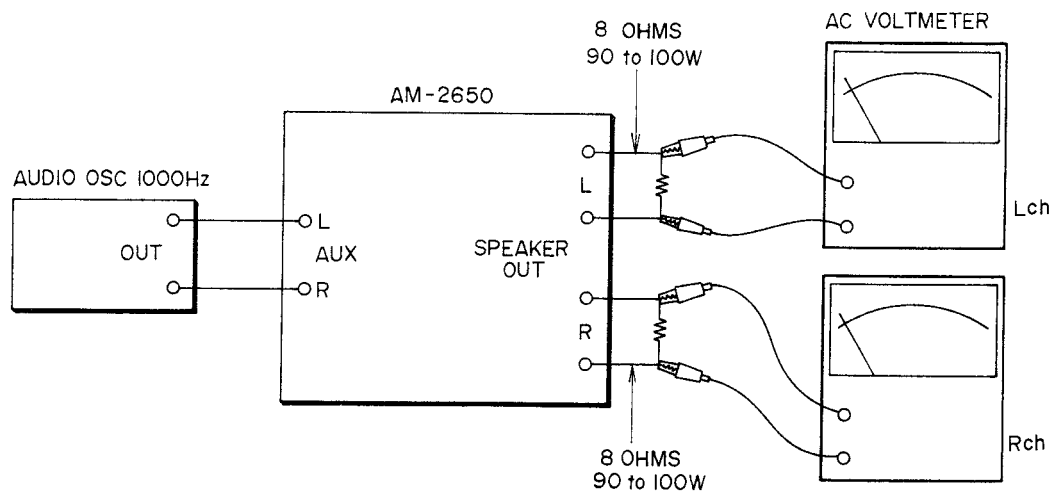

Fig. 28 Instrument Connection

2. LEVEL METER INDICATION ADJUSTMENT (Refer to Figs. 27, 28)

- 1) Connect a load of 8 ohms and AC Voltmeter (approx 50V range) to the speaker terminals in parallel.
- 2) Supply a signal of 1,000 Hz to the AUX Terminal.
- 3) Adjust main volume so that 22.8V is indicated by the AC Voltmeter.
- 4) Adjust semi-fixed volumes VR3 500B (L ch), and VR2 500B (R ch) on the Main Amp P.C Board. Level meter indication should be "65" with the above condition.

XI. TUNING CORD THREADING

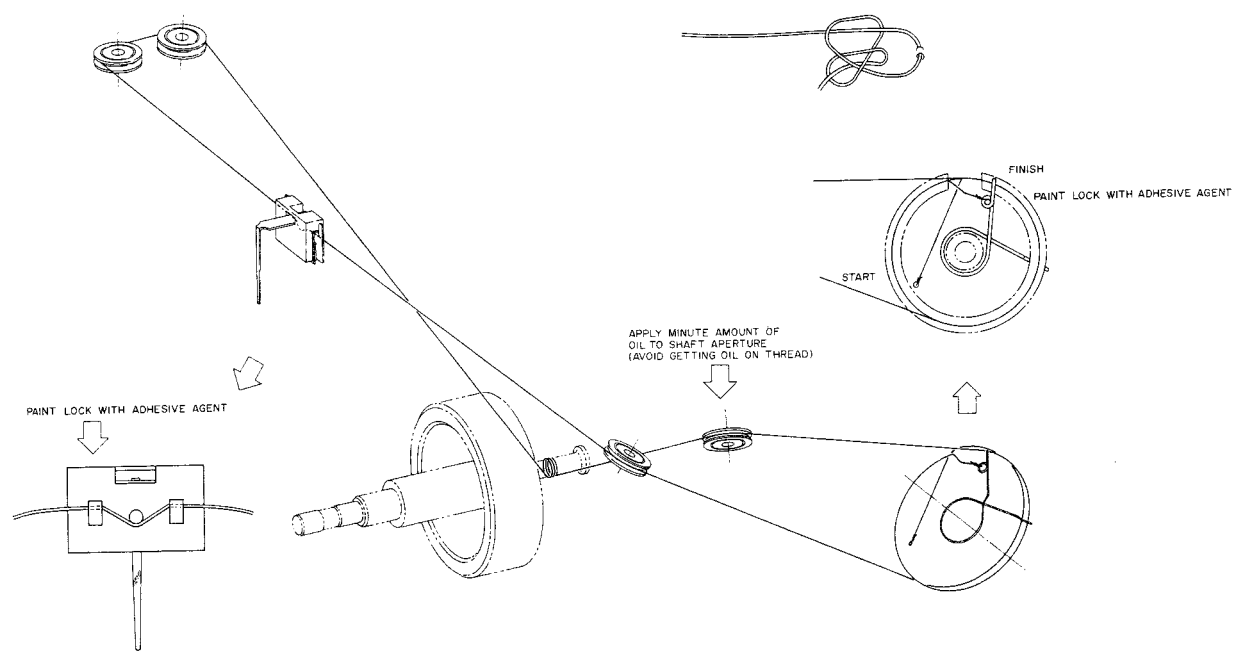

Fig. 29 Tuning Cord Threading

XII. CLASSIFICATION OF VARIOUS P.C BOARDS

1. P.C BOARD TITLES AND IDENTIFICATION NUMBERS

1) Model AT-2650

P.C Board Title	P.C Board Number
Tuner P.C Board	T3-6501A
Power Supply P.C Board	T3-4502
LED P.C Board	T3-6501B
Filter P.C Board	T3-6501C

Chart-4

2) Model AM-2650

P.C Board Title	P.C Board Number
Main Amp P.C Board	M3-6504A/B
Tone Control P.C Board	M3-6503
Main Vol. & Balance P.C Board	M3-6502A/B
Input P.C Board	M3-6501A
Tape P.C Board	M3-6501B
LED P.C Board	M3-6504C

Chart-5

2. MODEL AT-2650 COMPOSITION OF VARIOUS P.C BOARDS

1) TUNER P.C BOARD T3-6501A (2ED), LED P.C BOARD T3-6501B & FILTER P.C BOARD T3-6501C

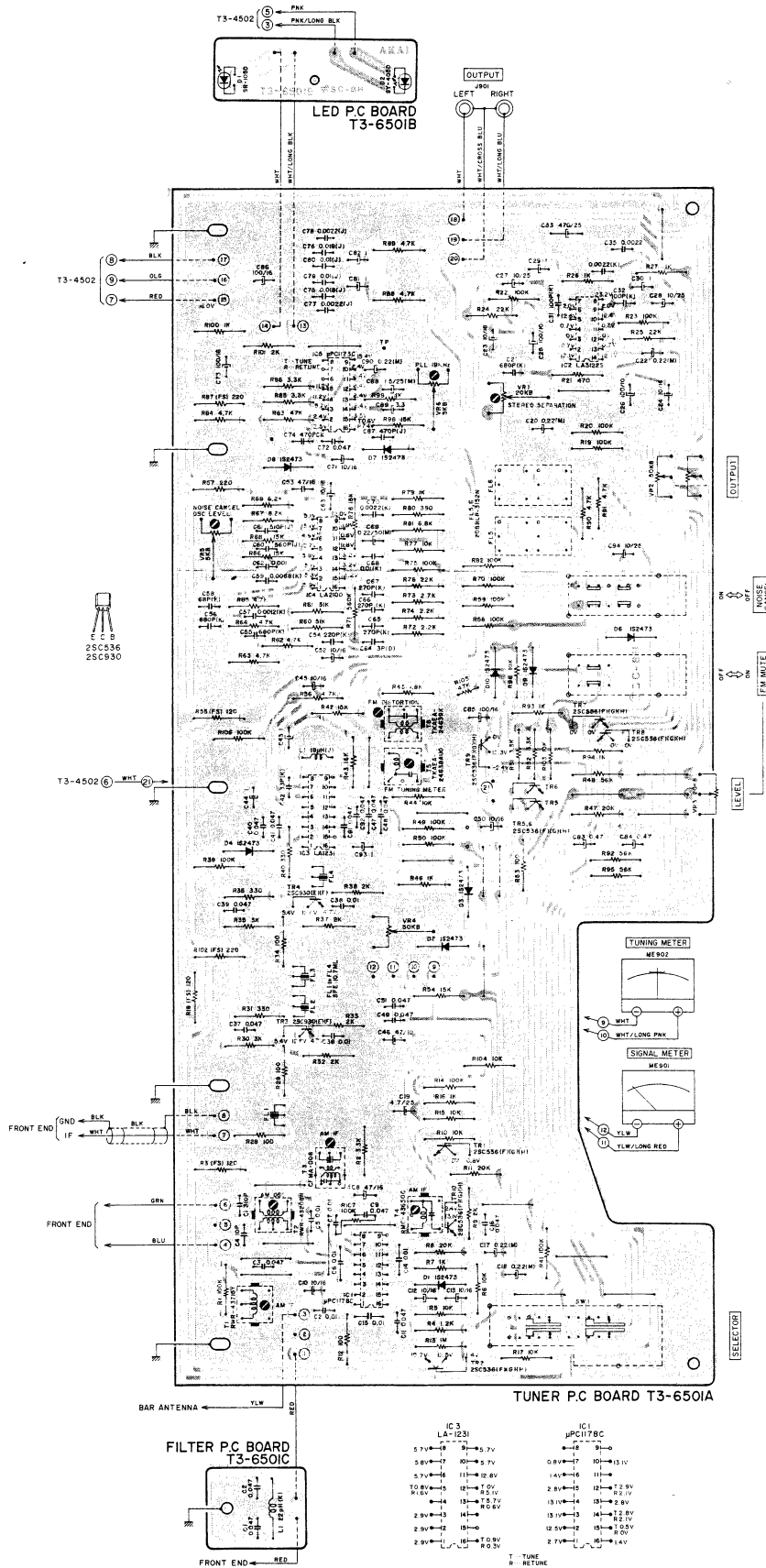

2) POWER SUPPLY P.C BOARD T3-4502 (U/T)

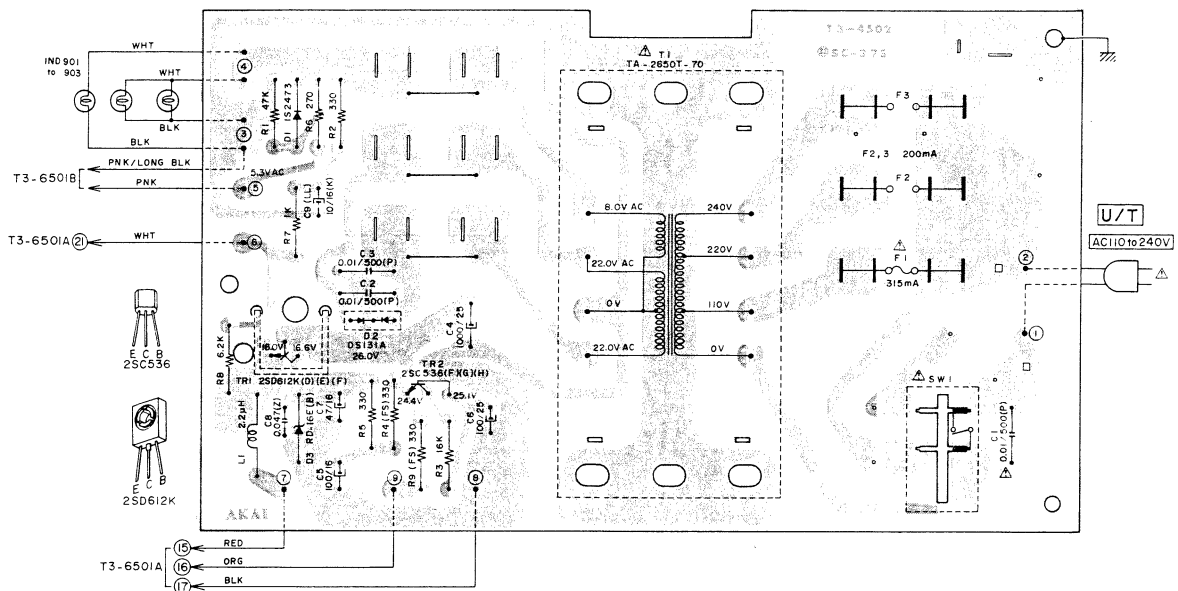

3) POWER SUPPLY P.C BOARD T3-4502 (CSA, AAL)

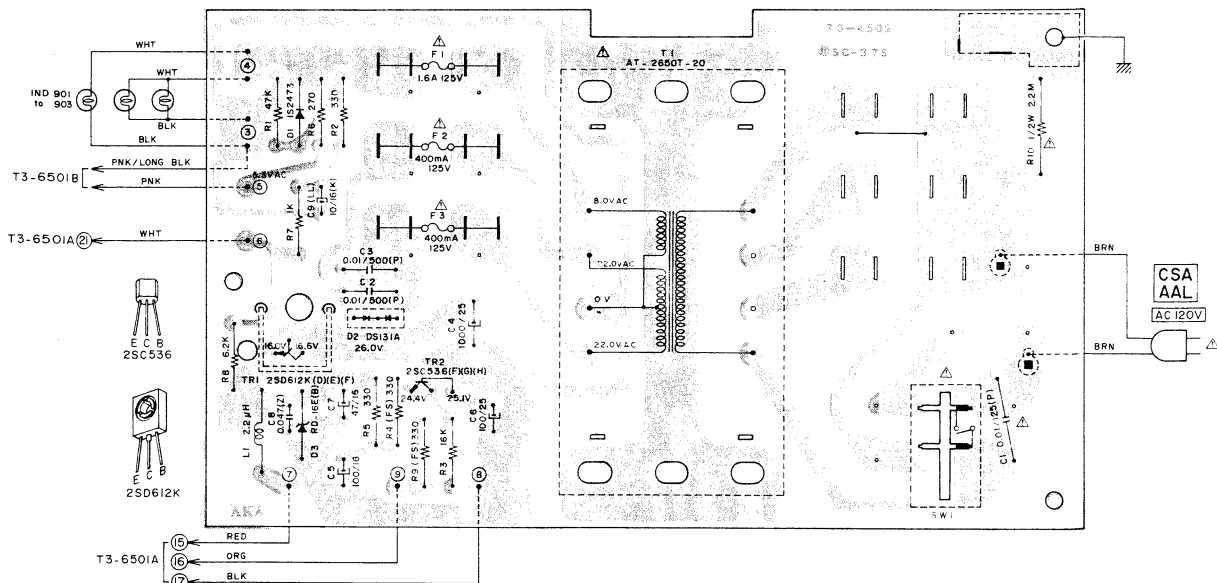

WARNING: Δ INDICATES SAFETY CRITICAL COMPONENTS. FOR CONTINUED SAFETY, REPLACE SAFETY CRITICAL COMPONENTS ONLY WITH MANUFACTURER'S RECOMMENDED PARTS.

AVERTISSEMENT: Δ IL INDIQUE LES COMPOSANTS CRITIQUES DE SÛRETÉ. POUR MAINTENIR LE DEGRÉ DE SÛRETÉ DE L'APPAREIL, NE REMPLACEZ LES COMPOSANTS DONT LE FONCTIONNEMENT EST CRITIQUE POUR LA SÛRETÉ QUE PAR DES PIÈCES RECOMMANDÉES PAR LE FABRICANT.

4) POWER SUPPLY P.C BOARD T3-4502 (CEE)

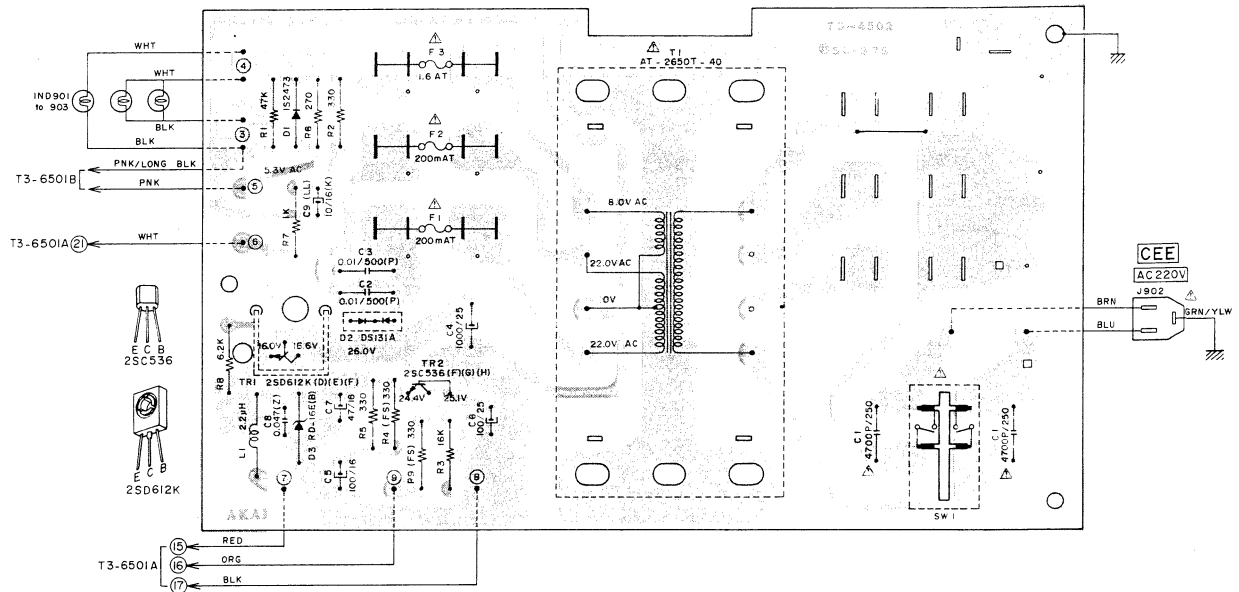

5) POWER SUPPLY P.C BOARD T3-4502 (UK)

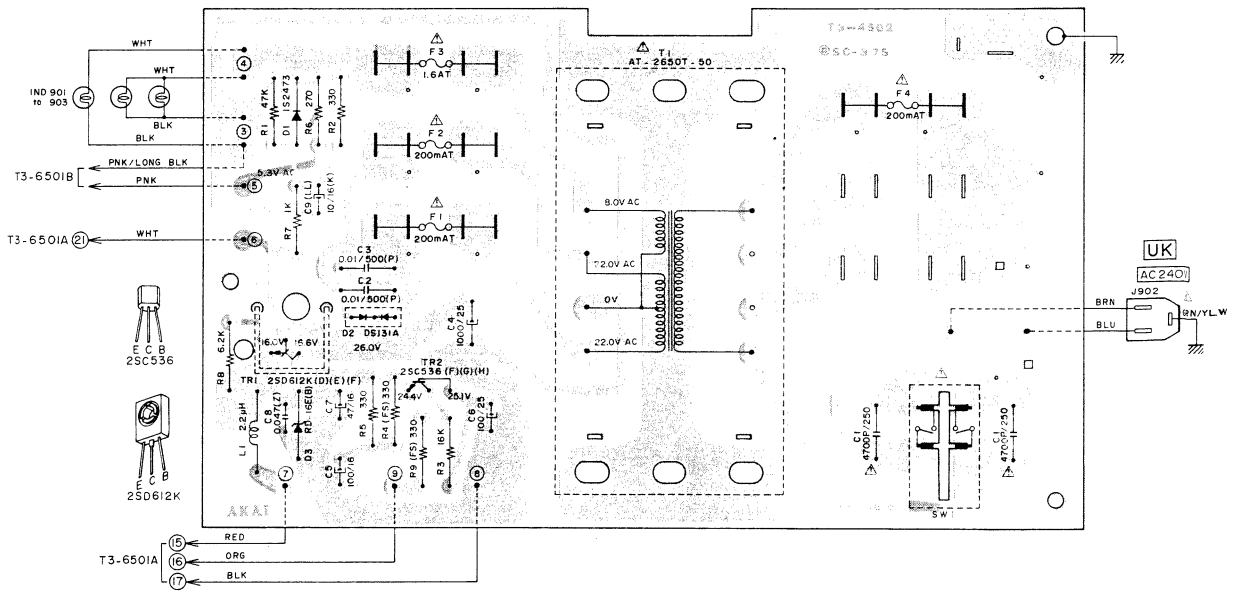

WARNING: Δ INDICATES SAFETY CRITICAL COMPONENTS. FOR CONTINUED SAFETY, REPLACE SAFETY CRITICAL COMPONENTS ONLY WITH MANUFACTURER'S RECOMMENDED PARTS.
 AVERTISSEMENT: Δ IL INDIQUE LES COMPOSANTS CRITIQUES DE SÛRETÉ. POUR MAINTENIR LE DEGRÉ DE SÛRETÉ DE L'APPAREIL NE REMPLACER LES COMPOSANTS DONT LE FONCTIONNEMENT EST CRITIQUE POUR LA SÛRETÉ QUE PAR DES PIÈCES RECOMMANDÉES PAR LE FABRICANT.

3. MODEL AM-2650 COMPOSITION OF VARIOUS P.C BOARDS

1) MAIN AMP P.C BOARD M3-6504A/B & LED P.C BOARD M3-6504C

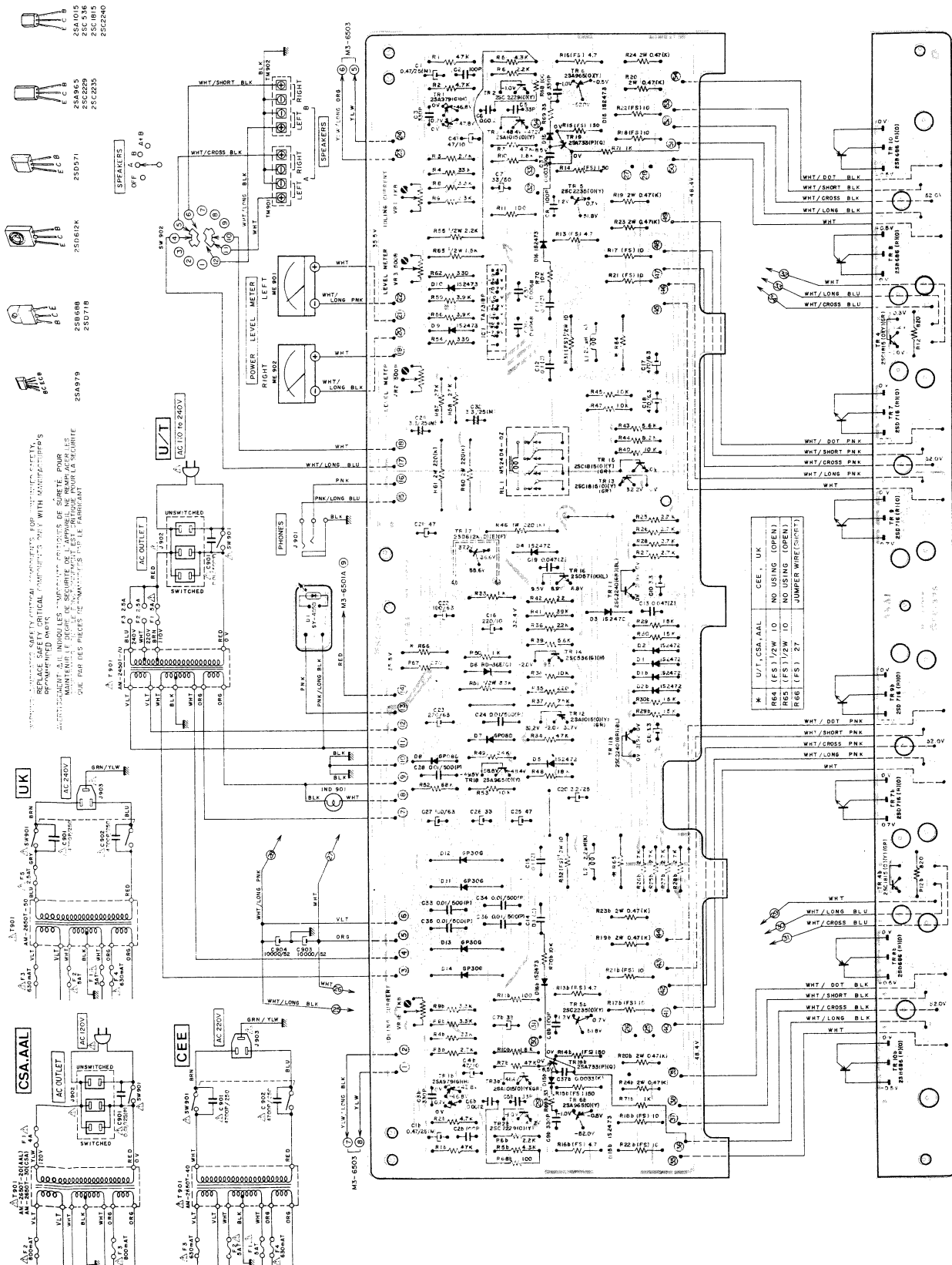

2) TONE CONTROL P.C BOARD M3-6503

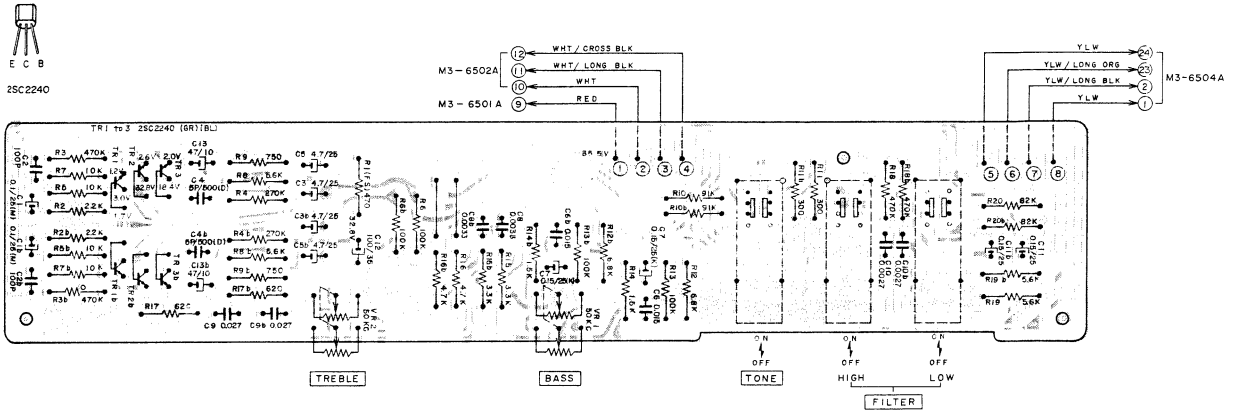

3) MAIN VOL. & BALANCE P.C BOARD M3-6502A/B

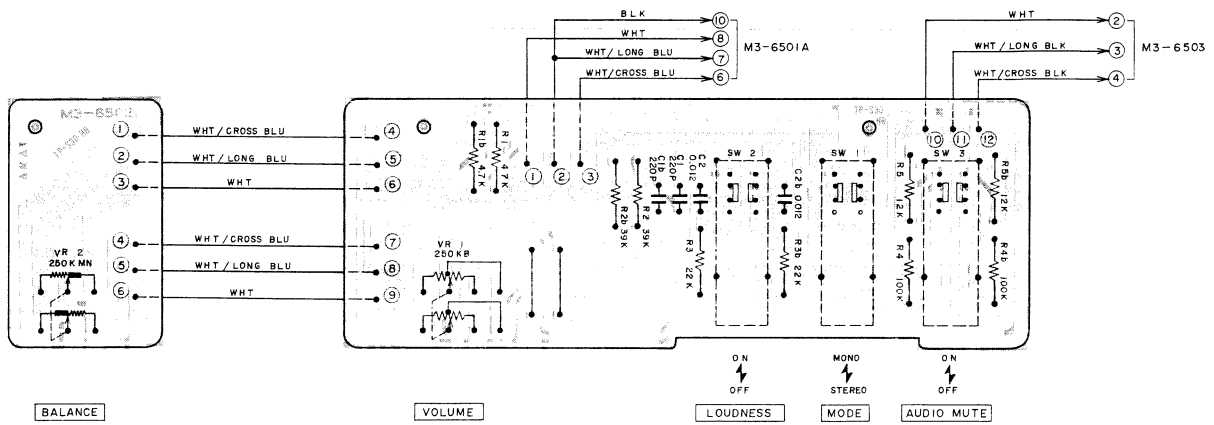

4) INPUT P.C BOARD M3-6501A

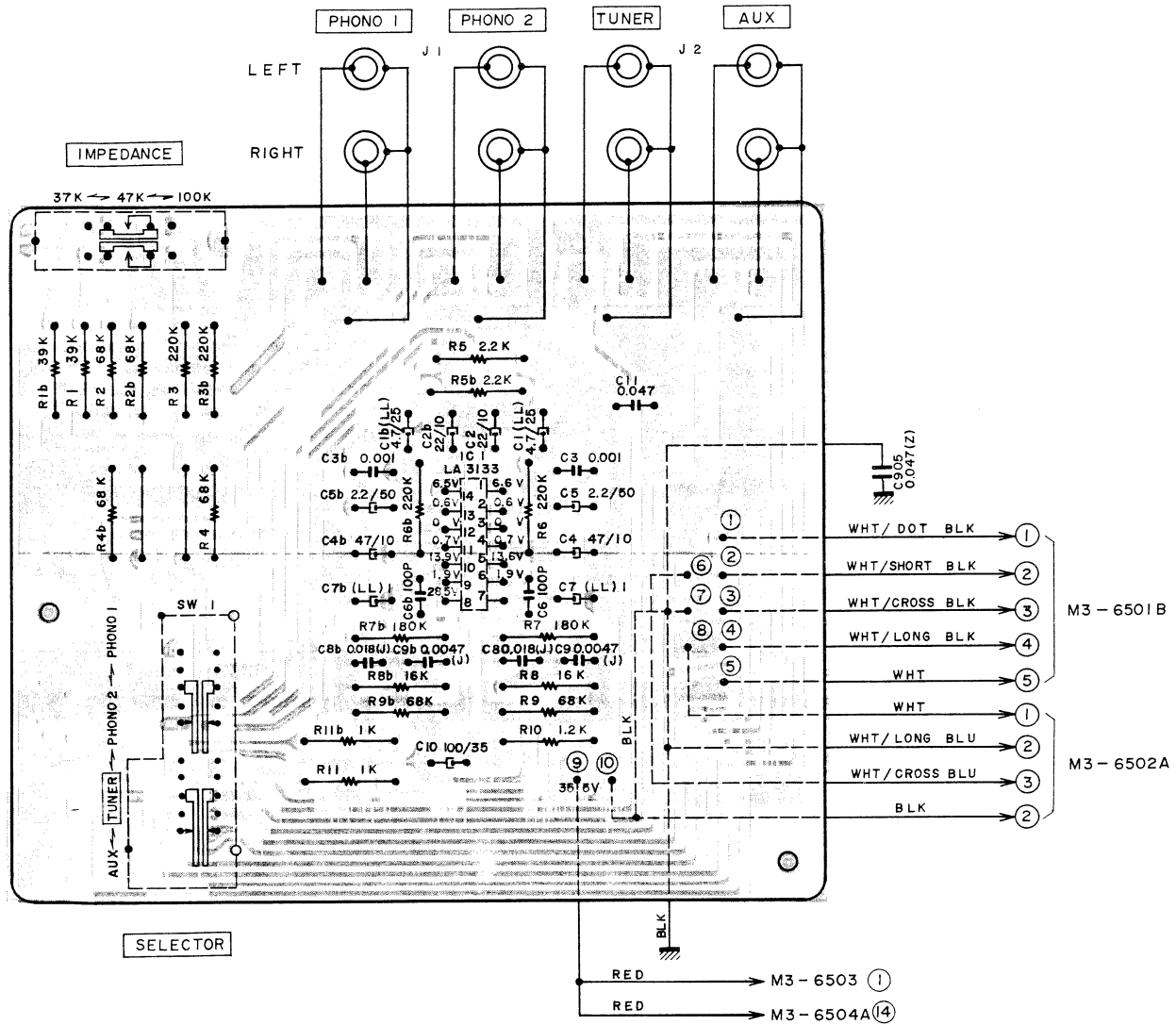

5) TAPE P.C BOARD M3-6501B

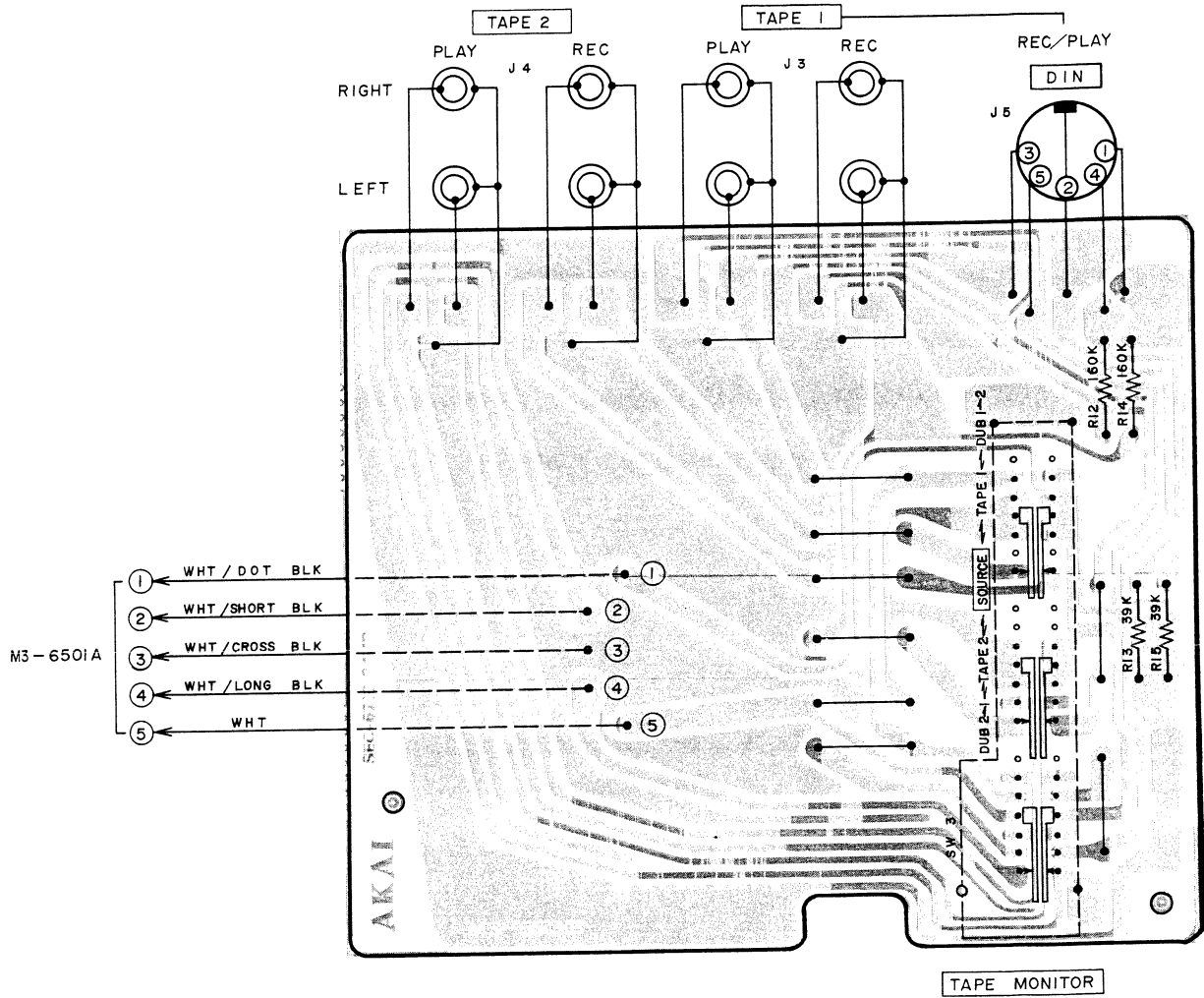

SECTION 2

PARTS LIST

TABLE OF CONTENTS

1. RECOMMENDED SPARE PARTS LIST	38
MODEL AT-2650	
2. TUNER P.C BOARD (T3-6501A) BLOCK	40
3. FILTER P.C BOARD (T3-6501C) BLOCK	40
4. POWER SUPPLY P.C BOARD (T3-4502) BLOCK	41
5. ASSEMBLY BLOCK	42
6. FINAL ASSEMBLY BLOCK	44
MODEL AM-2650	
7. INPUT & TAPE P.C BOARD (M3-6501A/B) BLOCK	45
8. MAIN VOL. & BALANCE P.C BOARD (M3-6502A/B) BLOCK	45
9. TONE CONTROL P.C BOARD (M3-6503) BLOCK	46
10. MAIN AMP P.C BOARD (M3-6504A) BLOCK	46
11. ASSEMBLY BLOCK	48
12. FINAL ASSEMBLY BLOCK	50
INDEX	51

Resistor and Capacitor which is not listed in this parts list, please refer to COMMON LIST FOR SERVICE PARTS.

HOW TO USE THIS PARTS LIST

1. This parts list is compiled by various individual blocks based on assembly process.
2. When ordering parts, please describe parts number, serial number, and model number in detail.
3. How to read list.

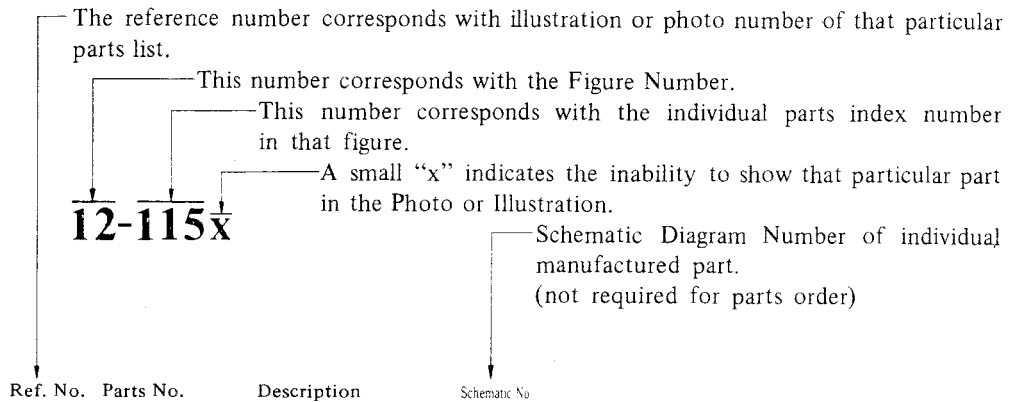

Ref. No.	Parts No.	Description	Schematic No.
FLYWHEEL BLOCK #13			
12-115x	800425	Flywheel Block Assy. Comp.	RDG #13
12-116	244506	Flywheel Only	RD-233
12-117x	244754	Felt, Flywheel	RD-275
12-118	251324	Main Metal Case	RD-236
12-119	253080	Main Metal	RD-237

4. The symbol numbers shown on the P.C. Board list can be matched with the Composite Views of components of the Schematic Diagram or Service Manual.
5. The indications of Resistors and Capacitors in the photos of P.C. Board are being eliminated.
6. The shape of the parts and parts name, etc. can be confirmed by comparing them with the parts shown on the Electrical Parts Table of P.C. Board.
7. Both the kind of part and installation position can be determined by the Parts Number. To determine where a parts number is listed, utilize Parts Index at end of Parts List.
It is necessary first of all to find the Parts Number. This can be accomplished by using the Reference Number listed at right of parts number in the Parts Index. (meaning of ref. no. outlined in Item 3 above).
8. Utilize separate "Price List for Parts" to determine unit price. The most simple method of finding parts Price is to utilize the reference number.

CAUTION:

1. When placing an order for parts, be sure to list the parts no., model no., and description. There are instances in which if any of this information is omitted, parts cannot be shipped or the wrong parts will be delivered.
2. Please be careful not to make a mistake in the parts no. If the parts no. is in error, a part different from the one ordered may be delivered.
3. Because parts number and parts unit supply in the Preliminary Service Manual (Basic Parts List) may be partially changed, please use this parts list for all future reference.

WARNING: △ INDICATES SAFETY CRITICAL COMPONENTS. FOR CONTINUED SAFETY, REPLACE SAFETY CRITICAL COMPONENTS ONLY WITH MANUFACTURER'S RECOMEMNDED PARTS.

AVERTISSEMENT: △ IL INDIQU LES COMPOSANTS CRITIQUES DE SURETE. POUR MAINTENIR LE DEGRE DE SECURITE DE L'APPAREIL NE REMPLACER LES COMPOSANTS DONT LE FONCTIONNEMENT EST CRITIQUE POUR LA SECURITE QUE PAR DES PIECES RECOM. MANDEES PAR LE FABRICANT.

AC INLET SYSTEM

This model is equipped with an AC INLET SYSTEM. Please refer to the AC INLET SYSTEM CHART below for the specific type. By the AC INLET SYSTEM, AC (mains) cord can be connected to and disconnected from the model because the model is provided with socket exclusively for AC (mains) cord on its main body.

Please note, however, that certain models are not equipped with this system and has a built-in AC (mains) cord as before.

AC INLET SYSTEM CHART

CLASS I

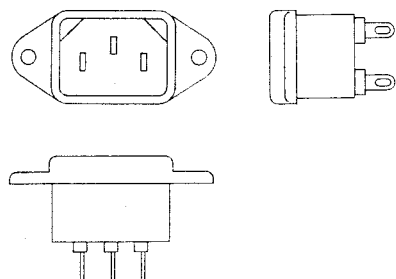

Picture 1
AC INLET
to be
installed
on machines

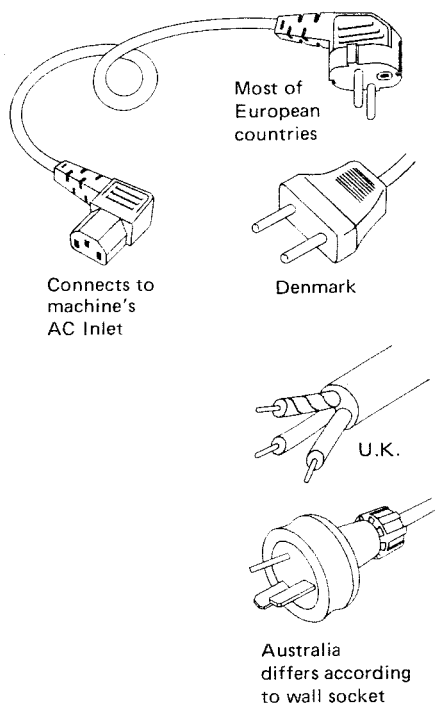

Picture 2
AC (mains)
cord

CLASS II

☐ This mark indicating double insulation will be attached to machine's rear panel

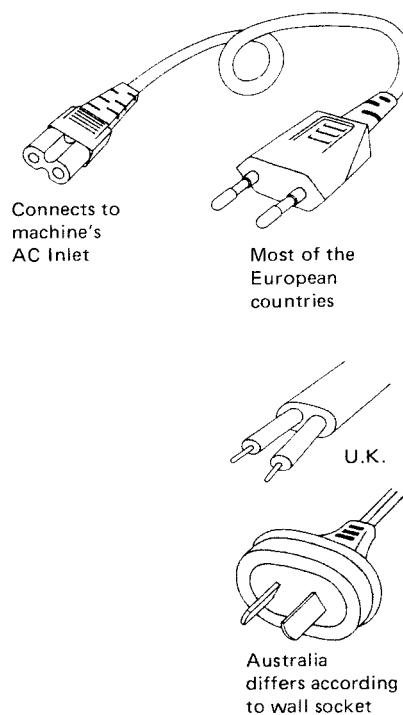
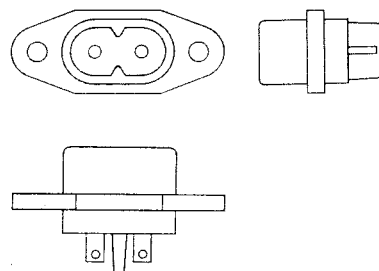

Parts List for AC (mains) Cord Set

	Standard	Description	Type of AC Inlet	Parts No.
Class I	CEE	Cord Set CEE (3 cores)	3P	EW302993
	BEAB	Cord Set BEAB (3 cores)	3P	EW302994
	SAA	Cord Set SAA (3 cores)	3P	EW302996
	U/T	Cord Set U/T (3 cores)	3P	EW302646
Class II	CEE	Cord Set CEE (2 cores)	2P	EW638144
	BEAB	Cord Set BEAB (2 cores)	2P	EW302995
	SAA	Cord Set SAA (2 cores)	2P	EW302991
	U/T	Cord Set U/T (2 cores)	2P	EW302899

1. RECOMMENDED SPARE PARTS LIST

Because, if the parts listed below are on hand, almost any repair can be accomplished, we suggest that you stock these Recommended Spare Parts Items.

Model AT-2650/BL

Parts No.	Description	Note
BA311920	Tuner P.C Board Comp. AT-2650	
BA308069	Power Supply P.C Board Comp. AT-2450 (U/T)	
BA308067	Power Supply P.C Board Comp. AT-2450 (CSA) (AAL)	
BA308066	Power Supply P.C Board Comp. AT-2450 (CEE)	
BA311178	Power Supply P.C Board Comp. AT-2450 (UK)	
BT308859	△ Power Trans. AT-2650T-70	U/T
BT308829	△ Power Trans. AT-2650T-20	CSA, AAL
BT308830	△ Power Trans. AT-2650T-40	CEE
BT308831	△ Power Trans. AT-2650T-50	UK
ED624903	Silicon Diode 1S2473	
ED223547	Silicon Diode DS131A	
ED308860	Zener Diode RD-16E (B)	
ED698826	LED SR-105D	
ED308592	LED SY-405D	
EF306125	△ Fuse 315mA 250V	U/T
EF308933	△ Fuse 200mA 250V	U/T
EF308848	△ Fuse 400mA 125V	CSA, AAL
EF308847	△ Fuse 1.6A 125V	CSA, AAL
EF300596	△ Fuse (FST) 200mAT	CEE, UK
EF601964	△ Fuse (SEMKO T Type) 1.6AT	CEE, UK
EI307199	IC μ PC1178C	
EI697871	IC LA-3122S	
EI307198	IC LA1231	
EI310299	IC LA2100	
EI308850	IC μ PC1173C	
EL307157	Lamp (Cord Type) 8V 300mA (300mm x 2)	
EL308839	Lamp (Cord Type) 8V 300mA (500mm x 2)	
EL308840	Lamp (Cord Type) 8V 300mA (600mm x 2)	
EM308844	Signal Meter KL-243X-35	
EM300355	Signal Meter KL-243X-26	BL
EM308843	Tuning Meter KL-243X-36	
EM300354	Tuning Meter KL-243X-27	BL
ER308617	Ceramic Filter SFE10.7ML-Z	
ER308855	Low Pass Filter 208BLR-3152N	
ES308852	Rotary SW. SRZK-043S	
ES310169	Lever SW. SLR522	
ES310301	Lever SW. SLR542	
ES308858	△ Push SW. JP29 (w/o label)	U/T
ES308863	△ Push SW. JP29 (w/label)	CSA, AAL
ES242346	△ Push SW. JP17	CEE, UK
ET632215	Transistor 2SC536 (F) (G) (H)	
ET618873	Transistor 2SC930 (E) (F)	
ET307193	Transistor 2SD612K (D) (E) (F)	

Model AM-2650/BL

Parts No.	Description	Note
BA311962	Input & Tape P.C Board Comp. AM-2650	
BA311967	Tone Control P.C Board Comp. AM-2650	
BA311955	Main Amp P.C Board Comp. AM-2650 (U/T) (CSA)	
BA311956	Main Amp P.C Board Comp. AM-2650 (CEE) (UK)	
BT310145	△ Power Trans. AM-2650T-70	U/T
BT310142	△ Power Trans. AM-2650T-30	CSA
BT310141	△ Power Trans. AM-2650T-20	AAL
BT310143	△ Power Trans. AM-2650T-40	CEE
BT310144	△ Power Trans. AM-2650T-50	UK
ED214457	Silicon Diode 1S2472	
ED240377	Zener Diode RD36E (C)	
ED300924	Silicon Diode GP08D	
ED624903	Silicon Diode 1S2473	
ED245428	Silicon Diode GP30G	
EF575223	△ Fuse 5A 250V	U/T
EF562691	△ Fuse 2.5A 250V	U/T
EF378595	△ Fuse ST-6 4A	CSA, AAL
EF277424	△ Fuse ST-4 0.8A	CSA, AAL
EF249851	△ Fuse (SEMKO T Type) 5AT	CEE, UK
EF601942	△ Fuse (SEMKO T Type) 630MAT	CEE, UK
EF623125	△ Fuse (SEMKO T Type) 2.5AT	UK
EI305696	IC LA3123	
EI308865	IC TA7318P	
EJ293365	4P PIN Jack	
EJ698051	DIN Jack	
EJ301199	Headphone Jack 3P64M	
EJ306942	4P Push Terminal S-Q2361	
EM310163	Level Meter D18C56R	
EM310164	Level Meter D18C57R	BL
EP245305	Relay MS24D4-0Z	
ES310171	Rotary SW. SRZ-K044T	
ES310170	Slide SW. 23460	
ES308884	Rotary SW. SRZ-K065T	
ES310169	Lever SW. SLR522	
ES224436	△ Push SW. JP01	U/T
ES280258	△ Push SW. SDV1P TV-5 (w/label)	CSA, AAL
ES242346	△ Push SW. JP17	CEE, UK
ES308581	Rotary SW. SR321N 1-2-4	
ET307195	Transistor 2SC2240 (GR) (BL)	
ET308866	Transistor 2SA979 (G) (H)	
ET310168	Transistor 2SC2229 (O) (Y)	
ET308867	Transistor 2SA1015 (O) (Y) (GR)	
ET305221	Transistor 2SC1815 (O) (Y) (GR)	
ET308870	Transistor 2SC2235 (O) (Y)	
ET308868	Transistor 2SA965 (O) (Y)	
ET310166	Transistor 2SD716 (AKAI) (R) (O)	
ET310165	Transistor 2SB686 (AKAI) (R) (O)	
ET310166	Transistor 2SD716 (AKAI) (R) (O)	
ET307195	Transistor 2SC2240 (GR) (BL)	
ET403391	Transistor 2SC536 (G) (H)	
ET666404	Transistor 2SD571 (K) (L)	
ET307193	Transistor 2SD612K (D) (E) (F)	
EW306428	△ AC Cord	U/T
EW305691	△ AC Cord CUL	CSA, AAL

MODEL AT-2650

2. TUNER P.C BOARD (T3-6501A) BLOCK

Symbol No.	Parts No.	Description	Schematic No.
2-1	BA311920	Tuner P.C Board Comp. AT-2650	
2-IC1	EI307199	IC μ PC1178C	45-8-268
2-IC2	EI697871	IC LA-3122S	45-8-185
2-IC3	EI307198	IC LA1231	45-8-267
2-IC4	EI310299	IC LA2100	45-8-319
2-IC5	EI308850	IC μ PC1173C	45-8-318
2-TR1,2	ET632215	Transistor 2SC536(F)(G)(H)	45-1-55
2-TR3,4	ET618873	Transistor 2SC930(E)(F)	45-1-185
2-TR5to10	ET632215	Transistor 2SC536(F)(G)(H)	45-1-55
2-D1to4	ED624903	Silicon Diode 1S2473	45-3-28
2-D6to10	ED624903	Silicon Diode 1S2473	45-3-28
2-T1	EO310302	AM-RF Coil RWR-43715Y	23-1-298
2-T2	EO307186	OSC Coil RWR-43208N	23-4-47
2-T3	BT307204	AM-IF Trans. CFMA-008	53-1-131
2-T4	EO307205	AM-IF Coil RMC-43650C	23-1-292
2-T5	EO307202	Detection Coil TKAEA-24638AUO	23-1-290
2-T6	EO307203	Detection Coil TKAEA-24639X	23-1-291
2-L1	EO650610	Inductor 144LZ 18 μ H(J)	23-1-240
2-FL1to4	ER308617	Ceramic Filter SFE10.7ML-Z	53-1-139
2-FL5,6	ER308855	Low Pass Filter 208BLR-3152N	53-1-140
2-SW1	ES308852	Rotary SW. SRZK-043S	25-6-160
2-SW2	ES310169	Lever SW. SLR522	25-12-43
2-SW3	ES310301	Lever SW. SLR542	25-12-45
2-VR1	EV560136	Semi-fixed/Vol. V10K8-4-2 20 kB	36-10-250
2-VR2	EV308854	Single Axial 2 Throw Vol. GM70R871C 50 kB \times 2	36-22-40
2-VR3	EV314538	Vol. VM10R907A-20 kB	36-6-37
2-VR4	EV308842	Semi-fixed/Vol. D10 Axial Type 50 kB	36-10-274
2-VR5,6	EV307246	Semi-fixed/Vol. D10 Axial Type 5 kB	36-10-274
2-C1	EC650406	Styrol/C. (Vert. Type) 310PF(J) 50WV	24-11-3
2-C60,61	EC435690	Styrol/C. (Vert. Type) 560PF(J) 50WV	24-11-3
2-C87	EC405898	Styrol/C. (Vert. Type) 470PF(J) 50WV	24-11-3
2-C88	EC638188	Solid Aluminum/C. (Vert. Type) 1.5 μ F(M) 25WV	24-19-2

3. FILTER P.C BOARD (T3-6501C) BLOCK

Symbol No.	Parts No.	Description	Schematic No.
3-L1	EO539820	Peaking Coil 2.2 μ H(K)	23-1-187

4. POWER SUPPLY P.C BOARD (T3-4502) BLOCK

Symbol No.	Parts No.	Description	Schematic No.
4-1	BA308069	Power Supply P.C Board Comp. AT-2450 (U/T)	T3-4550
4-2	BA308067	Power Supply P.C Board Comp. AT-2450 (CSA) (AAL)	T3-4550
4-3	BA308066	Power Supply P.C Board Comp. AT-2450 (CEE)	T3-4550
4-4	BA311178	Power Supply P.C Board Comp. AT-2450 (UK)	T3-4550
4-TR1	ET307193	Transistor 2SD612K(D)(E)(F)	45-1-308
4-TR2	ET632215	Transistor 2SC536(F)(G)(H)	45-1-55
4-D1	ED624903	Silicon Diode 1S2473	45-3-28
4-D2	ED223547	Silicon Diode DS131A	45-2-67
4-D3	ED308860	Zener Diode RD-16E(B)	45-6-72
4-L1	EO539820	Peaking Coil 2.2 μ H(K)	23-1-187
4-SW1	ES308858	Δ Push SW. JP29 (w/o label) (U/T)	25-5-299
4-SW1	ES308863	Δ Push SW. JP29 (w/label) (CSA, AAL)	25-5-300
4-SW1	ES242346	Δ Push SW. JP17 (CEE, UK)	25-5-224
4-5	ZS325495	Tapping Screw #2, 3x6 (BR)	
4-C1	EC204671	Δ Ceramic/C. DD31-6E 0.01 μ F(P) 500WV(U/T)	24-5-66
4-C1	EC294118	Δ Ceramic/C. DPN6600 YM 0.01 μ F(P) 125WV (CSA, AAL)	24-5-70
4-C1	EC301320	Δ MP/C. 4700PF(M) 250WV (CEE, UK)	24-9-122
4-C2,3	EC204671	Ceramic/C. DD31-6E 0.01 μ F(P) 500WV	24-5-66

5. ILLUSTRATION OF ASSEMBLY BLOCK

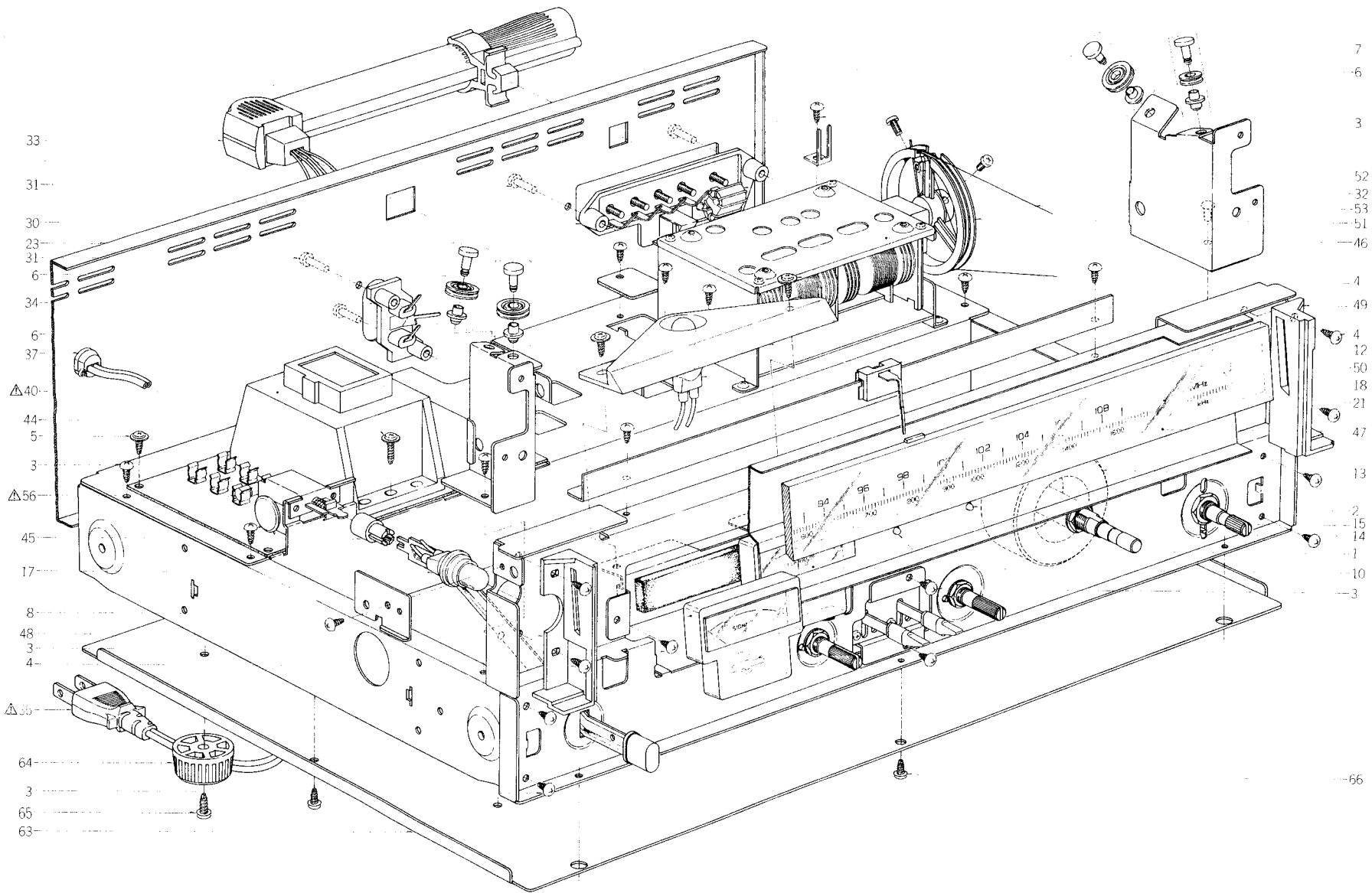

5) ASSEMBLY BLOCK

Ref. No.	Parts No.	Description	Schematic No.	Ref. No.	Parts No.	Description	Schematic No.
LED P.C BOARD BLOCK							
5-1	ED698826	LED SR-105D	45-15-16	5-54x	ZS434250	Screw, pan head 4x8, w/washer (CEE, UK)	
5-2	ED308592	LED SY-405D	45-15-20	5-55x	ZW413188	Nut M4, #1 (CEE, UK)	
ASSEMBLY BLOCK							
5-3	ZS325495	Tapping Screw #2, 3x6 (BR)		5-56	EF306125	△ Fuse 315mA 250V (U/T)	39-1-64
5-4	ZS498273	Tapping Screw #2, 3x8(BR) W=8		5-57x	EF308933	△ Fuse 200mA 250V (U/T)	39-1-64
5-5	ZS297641	Tapping Screw #2, 3x8(BIND) W=10		5-58x	EF308848	△ Fuse 400mA 125V (CSA, AAL)	39-1-65
5-6	MZ307170	Pulley	13-2-39	5-59x	EF308847	△ Fuse 1.6A 125V (CSA, AAL)	39-1-65
5-7	MR308836	Pulley	13-2-40	5-60x	EF300596	△ Fuse (FST) 200mAT (CEE, UK)	39-1-61
5-8	FM308844	Signal Meter KL-243X-35	46-1-214	5-61x	EF601964	△ Fuse (SEMKO T Type) 1.6AT (CEE, UK)	39-1-53
5-9x	EM300355	Signal Meter KL-243X-26(BL)	46-1-165	5-62x	EF300596	△ Fuse (FST) 200mAT (UK)	39-1-61
5-10	EM308843	Tuning Meter KL-243X-36	46-1-213	5-63	SP308634	Bottom Plate	T3-4523
5-11x	EM300354	Tuning Meter KL-243X-27(BL)	46-1-163	5-64	SA312465	Circular Foot(A) Part CA	CA-6014
5-12	TA308638	Meter Illumination Plate	T3-4526	5-65	ZS565942	Tapping Screw #2, 4x8(Pan)	
5-13	TA308837	Flywheel	13-2-46	5-66	ZS447840	Tapping Screw #2, 3x8(BR)	
5-14	ZW308889	Washer	25-6-160				
5-15	ZW308890	Nut	25-6-160				
5-16x	ZS379350	Screw, pan head 3x6					
5-17	EL307157	Lamp (Cord Type) 8V 300mA (300mmx2)	28-2-71				
5-18	EL308839	Lamp (Cord Type) 8V 300mA (500mmx2)	28-2-71				
5-19x	EL308840	Lamp (Cord Type) 8V 300mA (600mmx2)	28-2-71				
5-20x	ZW231030	Nylon Rivet (FNRP) 3x4.5 (Black)	2-7-54				
5-21	SP308606	Meter Panel	T3-4503				
5-22x	SP308607	Meter Panel (BL)	T3-4503				
5-23	SP310290	Rear Panel (F) (U)(U/T)	T3-6506				
5-24x	SP310291	Rear Panel (G) (C)(CSA)	T3-6506				
5-25x	SP310292	Rear Panel (H) (A)(AAL)	T3-6507				
5-26x	SP310293	Rear Panel (I) (E)(CEE)	T3-6507				
5-27x	SP310294	Rear Panel (J) (B)(UK)	T3-6508				
5-28x	ZS447761	Tapping Screw #2, 3x6(BR) (Black)					
5-29x	ZS308673	Tapping Screw 3x20 (Pan) w/guide (Except U/T)	7-1-68				
5-30	EJ308832	SP Antenna Terminal Plate UD-0059	32-1-92				
5-31	ZS522865	Tapping Screw #2, 3x12(BR) (Black)					
5-32	BT444137	Balum Trans. 75 ohms - 300 ohms	23-1-129				
5-33	EE310307	Bar Antenna	55-1-56				
5-34	EJ308834	2P PIN Jack T-5511	31-5-143				
5-35	EW306428	△ AC Cord (U/T)	26-3-64				
5-36x	EW305691	△ AC Cord CUL (CSA, AAL)	26-3-65				
5-37	EZ631945	Strain Relief SR-4N-4 (U/T, CSA, AAL)	2-7-49				
5-38x	EJ296853	△ 3P In-Let CM-3 (CEE, UK)	31-1-199				
5-39x	ZS463353	Tapping Screw #2, 3x8(BR) (Black) (CEE, UK)					
5-40	BT308859	△ Power Trans. AT-2650T-70(U/T)	38-4-666				
5-41x	BT308829	△ Power Trans. AT-2650T-20(CSA, AAL)	38-4-663				
5-42x	BT308830	△ Power Trans. AT-2650T-40(CEE)	38-4-664				
5-43x	BT308831	△ Power Trans. AT-2650T-50(UK)	38-4-665				
5-44	ZS308513	Tapping Screw #2, 3x12(BR) W=8					
5-45	TC289484	SW. Joint	CM-6015				
5-46	EE310308	Front End FB824U14	57-2-48				
5-47	TA310304	Scale Plate (B)	T3-4504				
5-48	TA308639	Scale Plate Support (L)	T3-4527				
5-49	TA308640	Scale Plate Support (R)	T3-4528				
5-50	TA308109	Pointer Part AT-2450	T3-4535				
5-51	MI301149	Dial Wheel	2-15-17				
5-52	ZG300891	Dial Wheel Spring	AB-3533				
5-53	TA307160	Dial String TK-1064 D0.5	8-2-1				

6. PHOTO OF FINAL ASSEMBLY BLOCK

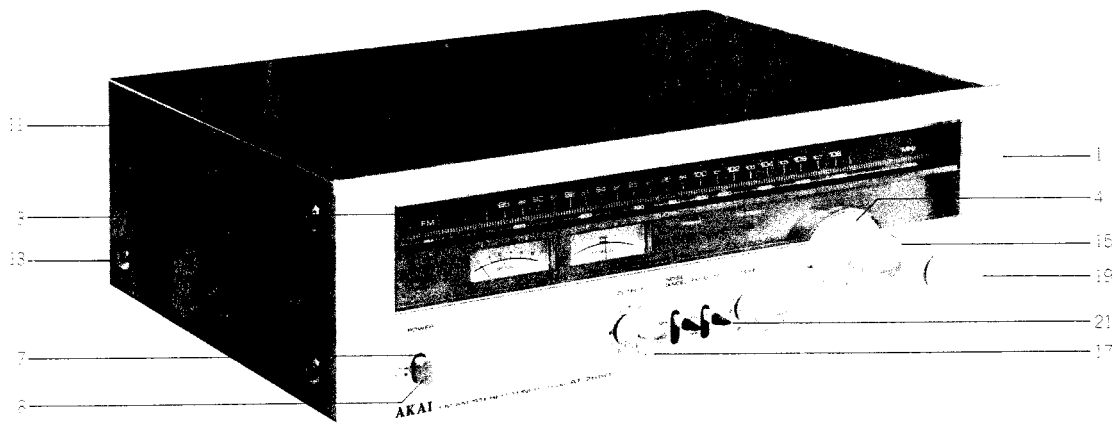

6) FINAL ASSEMBLY BLOCK

Ref. No.	Parts No.	Description	Schematic No.
FRONT PANEL BLOCK			
6-1	BD311924	Front Panel Block Comp. AT-2650	T3-6510
6-2x	BD311925	Front Panel Block Comp. AT-2650-BL	T3-6510
6-3	TA308613	Front Plate	T3-4507
6-4	SK308641	Tuning Knob Stand	T3-4529
6-5x	SK308642	Tuning Knob Stand (BL)	T3-4529
6-6x	ZS497878	Tapping Screw #2, 3x10 (BR) W=8	
6-7	SE308529	Button Escutcheon (A)	CY-6013
FINAL ASSEMBLY BLOCK			
6-8	SK305674	Power SW. Cap	CN-6338
6-9x	SK306130	Power SW. Cap (BL)	CN-6338
6-10x	ZS447840	Tapping Screw #2, 3x8 (BR)	
6-11	BC308635	Upper Cover (A) (Except AAL)	T3-4524
6-12x	BC308636	Upper Cover (B) (AAL)	T3-4524
6-13	ZS537006	Screw, binding head 4x8 (Black)	
6-14x	ZS308846	Tapping Screw #2, 3x8 (BR) (Oval Neck)	7-1-69
6-15	SK308643	Tuning Knob	T3-4530
6-16x	SK308644	Tuning Knob (BL)	T3-4530
6-17	SK308565	Knob (A)	M3-4531
6-18x	SK308566	Knob (A-BL)	M3-4531
6-19	SK308567	Knob (B)	M3-4532
6-20x	SK308568	Knob (B-BL)	M3-4532
6-21	SK310130	Lever Knob	M3-6515

MODEL AM-2650

7. INPUT & TAPE P.C BOARD (M3-6501A/B) BLOCK

Symbol No.	Parts No.	Description	Schematic No.
7-1	BA311962	Input & Tape P.C Board Comp. AM-2650	M3-6518
7-IC1	EI305696	IC LA3123	45-8-270
7-SW1	ES310171	Rotary SW. SRZ-K044T	25-6-159
7-SW2	ES310170	Slide SW. 23460	25-3-158
7-SW3	ES308884	Rotary SW. SRZ-K065T	25-6-158
7-J1to4	EJ293365	4P PIN Jack	31-1-197
7-J5	EJ698051	DIN Jack	31-1-158

8. MAIN VOL. & BALANCE P.C BOARD (M3-6502A/B) BLOCK

Symbol No.	Parts No.	Description	Schematic No.
8-VR1	EV307188	Single Axial 2 Throw Vol. GM80E-250 kBx2	36-22-35
8-VR2	EV307189	Single Axial 2 Throw Vol. GM70E-250 kMN	36-22-36
8-SW1to3	ES310169	Lever SW SLR522	25-12-43

9. TONE CONTROL P.C BOARD (M3-6503) BLOCK

Symbol No.	Parts No.	Description	Schematic No.
9-1	BA311967	Tone Control P.C Board Comp. AM-2650	M3-6519
9-TR1to3	ET307195	Transistor 2SC2240 (GR) (BL)	45-1-302
9-VR1,2	EV308596	Single Axial 2 Throw Vol. GM70E-50kCx2	36-22-39
9-SW1to3	ES310169	Lever SW. SLR522	25-12-43
9-R1	ER308598	Carbon/R. (Homing Type) F 1/4W 470 ohms (J)	35-11-25
9-C7	EC662308	Solid Aluminum/C. (Vert. Type) 0.15 μ F(K) 25WV	24-19-2
9-C11	EC662308	Solid Aluminum/C. (Vert. Type) 0.15 μ F(K) 25WV	24-19-2

10. MAIN AMP P.C BOARD (M3-6504A) BLOCK

Symbol No.	Parts No.	Description	Schematic No.
10-1	BA311955	Main Amp P.C Board Comp. AM-2650 (U/T) (CSA)	
10-2	BA311956	Main Amp P.C Board Comp. AM-2650 (CEE) (UK)	
10-IC1	EI308865	IC TA7318P	45-8-306
10-TR1	ET308866	Transistor 2SA979(G)(H)	45-1-324
10-TR2	ET310168	Transistor 2SC2229(O)(Y)	45-1-305
10-TR3	ET308867	Transistor 2SA1015 (O)(Y)(GR)	45-1-328
10-TR4	ET305221	Transistor 2SC1815 (O)(Y)(GR)	45-1-299
10-TR5	ET308870	Transistor 2SC2235(O)(Y)	45-1-331
10-TR6	ET308868	Transistor 2SA965(O)(Y)	45-1-329
10-TR7	ET310166	Transistor 2SD716 (AKAI)(R)(O)	45-1-332
10-TR8	ET310165	Transistor 2SB686 (AKAI)(R)(O)	45-1-330
10-TR9	ET310166	Transistor 2SD716 (AKAI)(R)(O)	45-1-332
10-TR10	ET310165	Transistor 2SB686 (AKAI)(R)(O)	45-1-330
10-TR11	ET307195	Transistor 2SC2240 (GR)(BL)	45-1-302
10-TR12	ET308867	Transistor 2SA1015 (O)(Y)(GR)	45-1-328
10-TR13	ET305221	Transistor 2SC1815 (O)(Y)(GR)	45-1-299
10-TR14	ET403391	Transistor 2SC536(G)(H)	45-1-55
10-TR15	ET305221	Transistor 2SC1815 (O)(Y)(GR)	45-1-299
10-TR16	ET666404	Transistor 2SD571(K)(L)	45-1-218
10-TR17	ET307193	Transistor 2SD612K (D)(E)(F)	45-1-306
10-TR18	ET308868	Transistor 2SA965(O)(Y)	45-1-329
10-D1to5	ED214457	Silicon Diode 1S2472	45-3-41
10-D6	ED240377	Zener Diode RD36E(C)	45-6-72
10-D7,8	ED300924	Silicon Diode GP08D	45-2-68
10-D9,10	ED624903	Silicon Diode 1S2473	45-3-28
10-D11to14	ED245428	Silicon Diode GP30G	45-2-69
10-RL1	EP245305	Relay MS24D4-OZ	47-1-28
10-L1,2	EO650823	Phase Compensation Coil 2.2 μ H(K)	23-1-239
10-VR1	EV300921	Semi-fixed/Vol. V10K8-1-2 1kB	36-10-255
10-VR2,3	EV301637	Semi-fixed/Vol. V10K8-1-2 500 ohms(B)	36-10-255
10-R13	ER308872	Carbon/R. (Homing Type) F 1/4W 4.7 ohms(J)	35-11-25
10-R14,15	ER308873	Carbon/R. (Homing Type) F 1/4W 150 ohms(J)	35-11-25
10-R16	ER308872	Carbon/R. (Homing Type) F 1/4W 4.7 ohms(J)	35-11-25
10-R17,18	ER310147	Carbon/R. (Homing Type) F 1/4W 10 ohms(J)	35-11-25
10-R19,20	ER310879	Cement/R. (Metal Plate) 2W 0.47 ohm(K)	36-16-82
10-R21,22	ER310147	Carbon/R. (Homing Type) F 1/4W 10 ohms(J)	35-11-25
10-R23,24	ER310879	Cement/R. (Metal Plate) 2W 0.47 ohm(K)	35-16-82
10-R31,32	ER308875	Carbon/R. (Homing Type) F 1/2W 10 ohms(J) (U/T, CSA)	35-11-27
10-R46	ER389687	Metal Oxide Film/R. 1W 220 ohms (K)	35-15-10
10-R60,61	ER409814	Metal Oxide Film/R. 2W 220 ohms(K)	35-15-8
10-R64,65	ER308875	Carbon/R. (Homing Type) F 1/2W 10 ohms(J)	35-11-27
10-R66	ER308876	Carbon/R. (Homing Type) F 1/4W 27 ohms(J) (U/T)	35-11-25

When ordering parts, please describe Parts Number, Description, and Model Number in detail.

Symbol No.	Parts No.	Description	Schematic No.
10-C1	EC621257	Solid Aluminum/C. (Vert. Type) 0.47 μ F(M) 25WV	24-19-2
10-C20	EC662128	Solid Aluminum/C. (Vert. Type) 2.2 μ F(M) 25WV	24-19-2
10-C29	EC308877	NP Elect./C. (Homing Type) 3.3 μ F(M) 25WV	24-17-31
10-C32	EC308877	NP Elect./C. (Homing Type) 3.3 μ F(M) 25WV	24-17-31
10-3	ZS325495	Tapping Screw #2, 3x6 (BR)	
10-4	ZS447840	Tapping Screw #2, 3x8 (BR)	
10-5	ZW310167	Insulator Washer AC331	45-16-35
10-6	ZS421806	Screw, pan head 3x8	

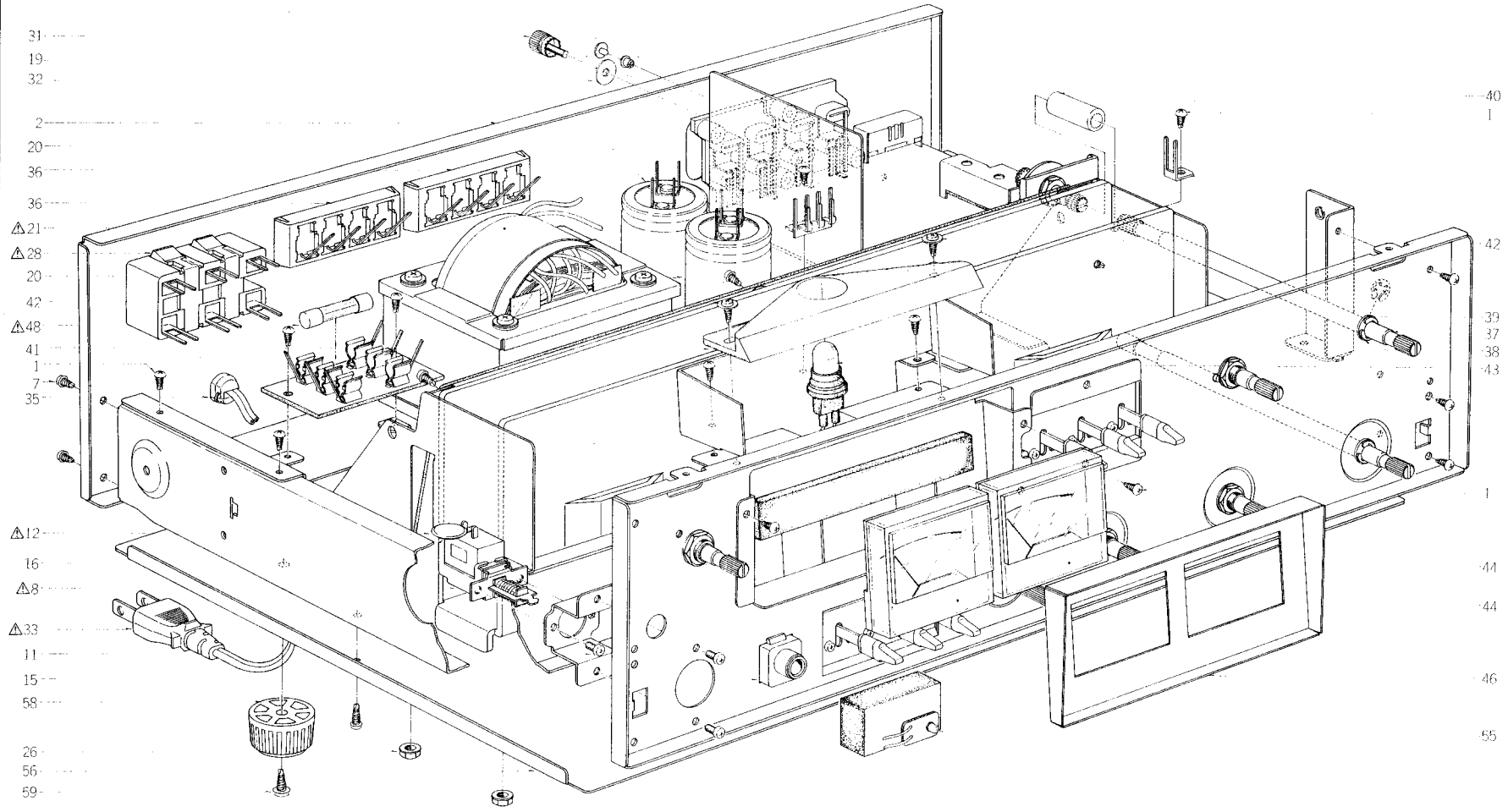

11. ILLUSTRATION OF ASSEMBLY BLOCK

11) ASSEMBLY BLOCK

Ref. No.	Parts No.	Description	Schematic No.	Ref. No.	Parts No.	Description	Schematic No.
11-1	ZS325495	Tapping Screw #2, 3x6 (BR)		LED P.C BOARD BLOCK			
11-2	SP310123	Rear Panel (A) (U)(U/T)	M3-6510	11-55	ED308592	LED SY-405D	45-15-20
11-3x	SP310125	Rear Panel (C) (C)(CSA)	M3-6511				
11-4x	SP310124	Rear Panel (B) (A)(AAL)	M3-6511				
11-5x	SP310126	Rear Panel (D) (E)(CEE)	M3-6512	11-56	SP308560	Bottom Plate	M3-4528
11-6x	SP310127	Rear Panel (E) (B)(UK)	M3-6512	11-57x	ZS447840	Tapping Screw #2, 3x8 (BR)	
11-7	ZS447761	Tapping Screw #2, 3x6(BR) (Black)		11-58	SA312465	Circular Foot (A) Part CA	CA-6014
11-8	ES224436	△ Push SW. JP01 (U/T)	25-5-221	11-59	ZS565942	Tapping Screw #2, 4x8 (Pan)	
11-9x	ES280258	△ Push SW. SDV1P TV-5 (w/label) (CSA, AAL)	25-5-243				
11-10x	ES242346	△ Push SW. JP17 (CEE, UK)	25-5-224				
11-11	ZS379350	Screw, pan head 3x6					
11-12	EC204671	△ Ceramic/C. DD31-6E 0.01μF(P) 500WV (U/T)	24-5-66				
11-13x	EC294118	△ Ceramic/C. DPN6600 YM 0.01μF(P) 125WV (CSA, AAL)	24-5-70				
11-14x	EC301320	△ MP/C. 4700PF(M) 250WV (CEE, UK)	24-9-122				
11-15	EJ301199	Headphone Jack 3P64M	31-2-83				
11-16	ES308581	Rotary SW. SR321N 1-2-4	25-7-51				
11-17x	ZS522865	Tapping Screw #2, 3x12 (BR) (Black)					
11-18x	ZS608185	Screw, pan head 2.6x4					
11-19	ZW698308	Nylon Rivet (FNRP) 3x5.5 (Black)	2-7-54				
11-20	EC308585	Elect./C. 10000μF 52WV	24-10-129				
11-21	BT310145	△ Power Trans. AM-2650T-70 (U/T)	38-4-662				
11-22x	BT310142	△ Power Trans. AM-2650T-30 (CSA)	38-4-659				
11-23x	BT310141	△ Power Trans. AM-2650T-20 (AAL)	38-4-658				
11-24x	BT310143	△ Power Trans. AM-2650T-40 (CEE)	38-4-660				
11-25x	BT310144	△ Power Trans. AM-2650T-50 (UK)	38-4-661				
11-26	ZW413267	Flange Nut M4					
11-27x	ZS434250	Screw, pan head 4x8 w/washer (CEE, UK)					
11-28	EJ240535	△ 3-throw AC Outlet (U/T, CSA, AAL)	31-1-173				
11-29x	EJ296853	△ 3P In-let CM-3 (CEE, UK)	31-1-199				
11-30x	ZS463353	Tapping Screw #2, 3x8 (BR) (Black) (CEE, UK)					
11-31	EJ306940	Earth Terminal	32-1-87				
11-32	ZW651082	Washer (SPC) D3.2x10x1t					
11-33	EW306428	△ AC Cord (U/T)	26-3-64				
11-34x	EW305691	△ AC Cord CUL (CSA, AAL)	26-3-65				
11-35	EZ631945	Strain Relief SR-4N-4 (U/T, CSA, AAL)	2-7-49				
11-36	EJ306942	4P Push Terminal S-Q2361	32-1-86				
11-37	MS308569	Relay Shaft	M3-4533				
11-38	ZW270123	'E' Ring 4M	6-1-9				
11-39	ZW322110	Washer (Nylon) D6.1x10x1t					
11-40	TA646773	Joint	AA-5240				
11-41	TA308638	Meter Illumination Plate	T3-4526				
11-42	ZS498273	Tapping Screw #2, 3x8 (BR) W=8					
11-43	EL308839	Lamp (Cord Type) 8V 300mA (500mmx2)	28-2-71				
11-44	EM310163	Level Meter D18C56R	46-1-210				
11-45x	EM310164	Level Meter D18C57R (BL)	46-1-211				
11-46	SP308535	Meter Panel	M3-4510, 4511				
11-47x	SP308536	Meter Panel (BL)	M3-4510, 4511				
11-48	EF575223	△ Fuse 5A 250V (U/T)	39-1-50				
11-49x	EF562691	△ Fuse 2.5A 250V (U/T)	39-1-50				
11-50x	EF378595	△ Fuse ST-6 4A (CSA, AAL)	39-1-63				
11-51x	EF277424	△ Fuse ST-4 0.8A (CSA, AAL)	39-1-28				
11-52x	EF249851	△ Fuse (SEMKO T Type) 5AT (CEE, UK)	39-1-53				
11-53x	EF601942	△ Fuse (SEMKO T Type) 630MAT (CEE, UK)	39-1-53				
11-54x	EF623125	△ Fuse (SEMKO T Type) 2.5AT (UK)	39-1-53				

12. PHOTO OF FINAL ASSEMBLY BLOCK

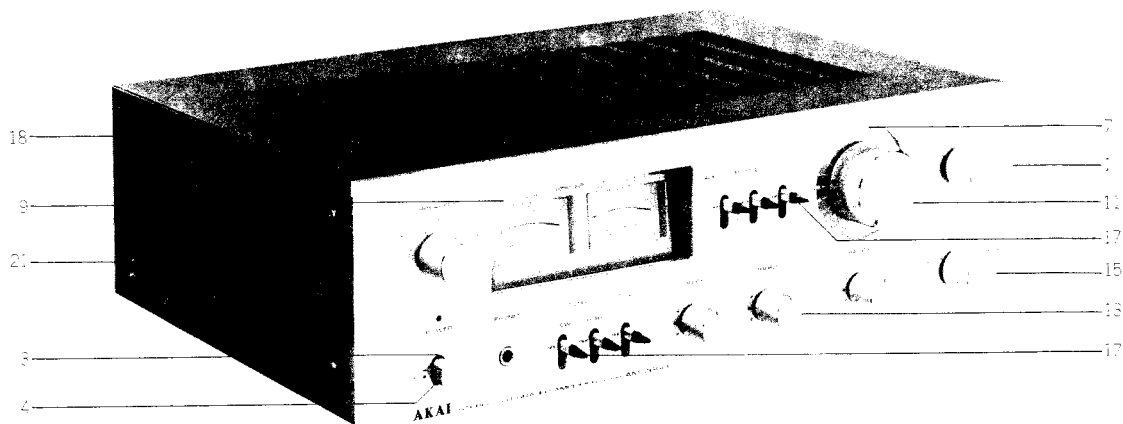

12) FINAL ASSEMBLY BLOCK

Ref. No.	Parts No.	Description	Schematic No.
FRONT PANEL BLOCK			
12-1	BD311969	Front Panel Block Comp. AM-2650	M3-6517
12-2x	BD311970	Front Panel Block Comp. AM-2650-BL	M3-6517
12-3	SE306863	Button Escutcheon	M3-2522
12-4	SK306864	Push Button	M3-2523
12-5x	SK306866	Push Button (BL)	M3-2523
12-6x	ZG306867	Taper Spring	M3-2524
12-7	TA308532	Vol. Plate	M3-4507, 4508
12-8x	TA308998	Vol. Plate (BL)	M3-4507, 4508
12-9	TA308534	Meter Plate	M3-4509
FINAL ASSEMBLY BLOCK			
12-10x	ZS447840	Tapping Screw #2, 3x8 (BR)	
12-11	SK308562	Vol. Knob	M3-4530
12-12x	SK308563	Vol. Knob (BL)	M3-4530
12-13	SK308565	Knob (A)	M3-4531
12-14x	SK308566	Knob (A-BL)	M3-4531
12-15	SK308567	Knob (B)	M3-4532
12-16x	SK308568	Knob (B-BL)	M3-4532
12-17	SK310130	Lever Knob	M3-6515
12-18	BC308561	Upper Cover (A) (Except AAL)	M3-4529
12-19x	BC308571	Upper Cover (B) (AAL)	M3-4529
12-20x	ZS447761	Tapping Screw #2, 3x6 (BR) (Black)	
12-21	ZS537006	Screw, binding head 4x8 (Black)	

INDEX

Parts No.	Ref. No. & Symbol No.	Parts No.	Ref. No. & Symbol No.	Parts No.	Ref. No. & Symbol No.	Parts No.	Ref. No. & Symbol No.	Parts No.	Ref. No. & Symbol No.
BA308066	4-3	EI310299	2-IC4	ET403391	10-TR14	ZG300891	5-52		
BA308067	4-2	EI697871	2-IC2	ET618873	2-TR3,4	ZG306867	12-6x		
BA308069	4-1	EJ240535	11-28	ET632215	2-TR1,2	ZS297641	5-5		
BA311178	4-4	EJ293365	7-J1to4	ET632215	2-TR5to10	ZS308513	5-44		
BA311920	2-1	EJ296853	5-38x	ET632215	4-TR2	ZS308673	5-29x		
BA311955	10-1	EJ296853	11-29x	ET666404	10-TR16	ZS308846	6-14x		
BA311956	10-2	EJ301199	11-15	EV300921	10-VR1	ZS325495	4-5		
BA311962	7-1	EJ306940	11-31	EV301637	10-VR2,3	ZS325495	5-3		
BA311967	9-1	EJ306942	11-36	EV307188	8-VR1	ZS325495	10-3		
BC308561	12-18	EJ308832	5-30	EV307189	8-VR2	ZS325495	11-1		
BC308571	12-19x	EJ308834	5-34	EV307246	2-VR5,6	ZS379350	5-16x		
BC308635	6-11	EJ698051	7-J5	EV308596	9-VR1,2	ZS379350	11-11		
BC308636	6-12x	EL307157	5-17	EV308842	2-VR4	ZS421806	10-6		
BD311924	6-1	EL308839	5-18	EV308854	2-VR2	ZS434250	5-54x		
BD311925	6-2x	EL308839	11-43	EV314538	2-VR3	ZS434250	11-27x		
BD311969	12-1	EL308840	5-19x	EV560136	2-VR1	ZS447761	5-28x		
BD311970	12-2x	EM300354	5-11x	EW305691	5-36x	ZS447761	11-7		
BT307204	2-T3	EM300355	5-9x	EW305691	11-34x	ZS447761	12-20x		
BT308829	5-41x	EM308843	5-10	EW306428	5-35	ZS447840	5-66		
BT308830	5-42x	EM308844	5-8	EW306428	11-33	ZS447840	6-10x		
BT308831	5-43x	EM310163	11-44	EZ631945	5-37	ZS447840	10-4		
BT308859	5-40	EM310164	11-45x	EZ631945	11-35	ZS447840	11-57x		
BT310141	11-23x	EO307186	2-T2	MI301149	5-51	ZS447840	12-10x		
BT310142	11-22x	EO307202	2-T5	MR308836	5-7	ZS463353	5-39x		
BT310143	11-24x	EO307203	2-T6	MS308569	11-37	ZS463353	11-30x		
BT310144	11-25x	EO307205	2-T4	MZ307170	5-6	ZS497878	6-6x		
BT310145	11-21	EO310302	2-T1	SA312465	5-64	ZS498273	5-4		
BT444137	5-32	EO539820	3-L1	SA312465	11-58	ZS498273	11-42		
EC204671	4-C1	EO539820	4-L1	SE306863	12-3	ZS522865	5-31		
EC204671	4-C2,3	EO650610	2-L1	SE308529	6-7	ZS522865	11-17x		
EC204671	11-12	EO650823	10-L1,2	SK305674	6-8	ZS537006	6-13		
EC294118	4-C1	EP245305	10-RL1	SK306130	6-9x	ZS537006	12-21		
EC294118	11-13x	ER308598	9-R1	SK306864	12-4	ZS565942	5-65		
EC301320	4-C1	ER308617	2-FL1to4	SK306866	12-5x	ZS565942	11-59		
EC301320	11-14x	ER308855	2-FL5,6	SK308562	12-11	ZS608185	11-18x		
EC308585	11-20	ER308872	10-R13	SK308563	12-12x	ZW231030	5-20x		
EC308877	10-C29	ER308872	10-R16	SK308565	6-17	ZW270123	11-38		
EC308877	10-C32	ER308873	10-R14,15	SK308565	12-13	ZW308889	5-14		
EC405898	2-C87	ER308875	10-R31,32	SK308566	6-18x	ZW308890	5-15		
EC435690	2-C60,61	ER308875	10-R64,65	SK308566	12-14x	ZW310167	10-5		
EC621257	10-C1	ER308876	10-R66	SK308567	6-19	ZW322110	11-39		
EC638188	2-C88	ER310147	10-R17,18	SK308567	12-15	ZW413188	5-55x		
EC650406	2-C1	ER310147	10-R21,22	SK308568	6-20x	ZW413267	11-26		
EC662128	10-C20	ER310879	10-R19,20	SK308568	12-16x	ZW651082	11-32		
EC662308	9-C7	ER310879	10-R23,24	SK308641	6-4	ZW698308	11-19		
EC662308	9-C11	ER389687	10-R46	SK308642	6-5x				
ED214457	10-D1to5	ER409814	10-R60,61	SK308643	6-15				
ED223547	4-D2	ES224436	11-8	SK308644	6-16x				
ED240377	10-D6	ES242346	4-SW1	SK310130	6-21				
ED245428	10-D11to14	ES242346	11-10x	SK310130	12-17				
ED300924	10-D7,8	ES280258	11-9x	SP308535	11-46				
ED308592	5-2	ES308581	11-16	SP308536	11-47x				
ED308592	11-55	ES308852	2-SW1	SP308560	11-56				
ED308860	4-D3	ES308858	4-SW1	SP308606	5-21				
ED624903	2-D1to4	ES308863	4-SW1	SP308607	5-22x				
ED624903	2-D6to10	ES308884	7-SW3	SP308634	5-63				
ED624903	4-D1	ES310169	2-SW2	SP310123	11-2				
ED624903	10-D9,10	ES310169	8-SW1to3	SP310124	11-4x				
ED698826	5-1	ES310169	9-SW1to3	SP310125	11-3x				
EE103307	5-33	ES310170	7-SW2	SP310126	11-5x				
EE310308	5-46	ES310171	7-SW1	SP310127	11-6x				
EF249851	11-52x	ES310301	2-SW3	SP310290	5-23				
EF277424	11-51x	ET305221	10-TR4	SP310291	5-24x				
EF300596	5-60x	ET305221	10-TR13	SP310292	5-25x				
EF300596	5-62x	ET305221	10-TR15	SP310293	5-26x				
EF306125	5-56	ET307193	4-TR1	SP310294	5-27x				
EF308847	5-59x	ET307193	10-TR17	TA307160	5-53				
EF308848	5-58x	ET307195	9-TR1to3	TA308109	5-50				
EF308933	5-57x	ET307195	10-TR11	TA308532	12-7				
EF378595	11-50x	ET308866	10-TR1	TA308534	12-9				
EF562691	11-49x	ET308867	10-TR3	TA308613	6-3				
EF575223	11-48	ET308867	10-TR12	TA308638	5-12				
EF601942	11-53x	ET308868	10-TR6	TA308638	11-41				
EF601964	5-61x	ET308868	10-TR18	TA308639	5-48				
EF623125	11-54x	ET308870	10-TR5	TA308640	5-49				
EI305696	7-IC1	ET310165	10-TR8	TA308837	5-13				
EI307198	2-IC3	ET310165	10-TR10	TA308998	12-8x				
EI307199	2-IC1	ET310166	10-TR7	TA310304	5-47				
EI308850	2-IC5	ET310166	10-TR9	TA646773	11-40				
EI308865	10-IC1	ET310168	10-TR2	TC289484	5-45				

SECTION 3

SCHEMATIC DIAGRAM

1. AT-2650 No.2-1 1562446A SCHEMATIC DIAGRAM
2. AM-2650 No.2-2 1562447A SCHEMATIC DIAGRAM

μ PC1178C

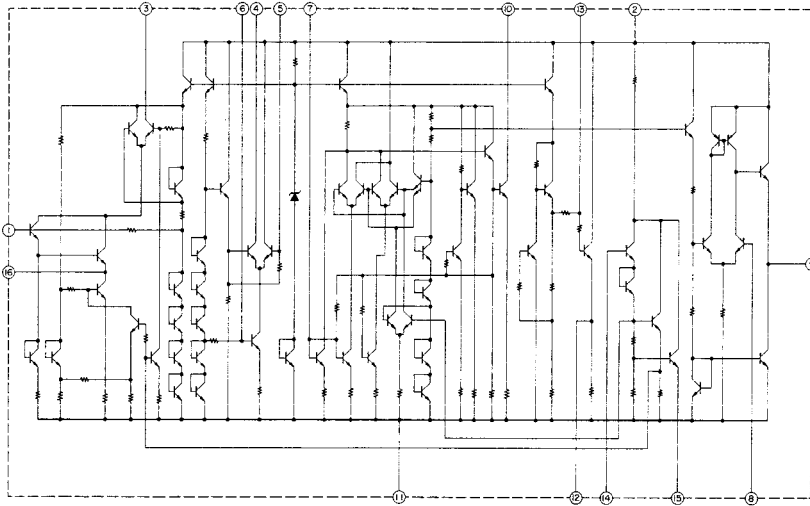

μ PC1173C

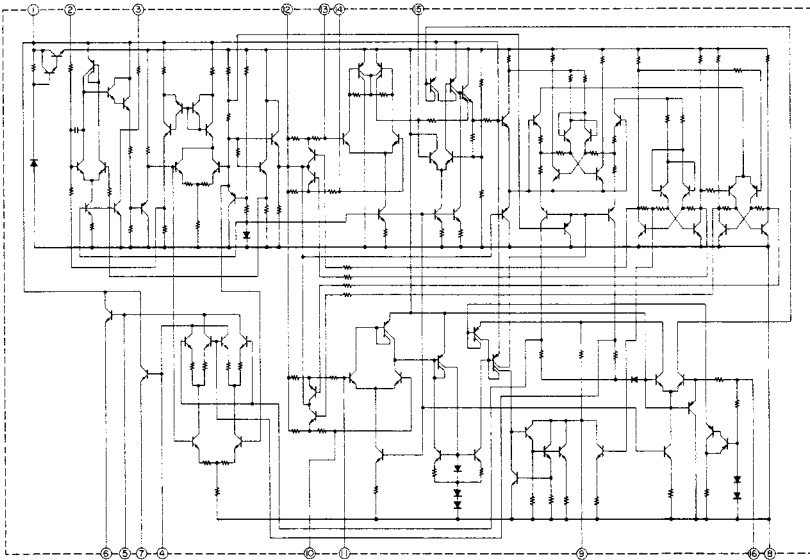

LA3122S/LA3133

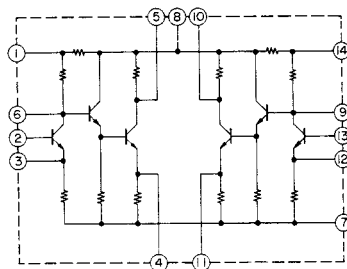

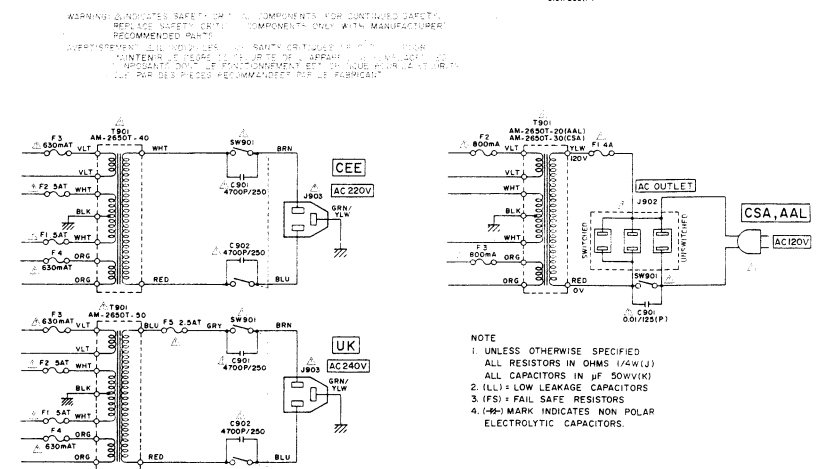
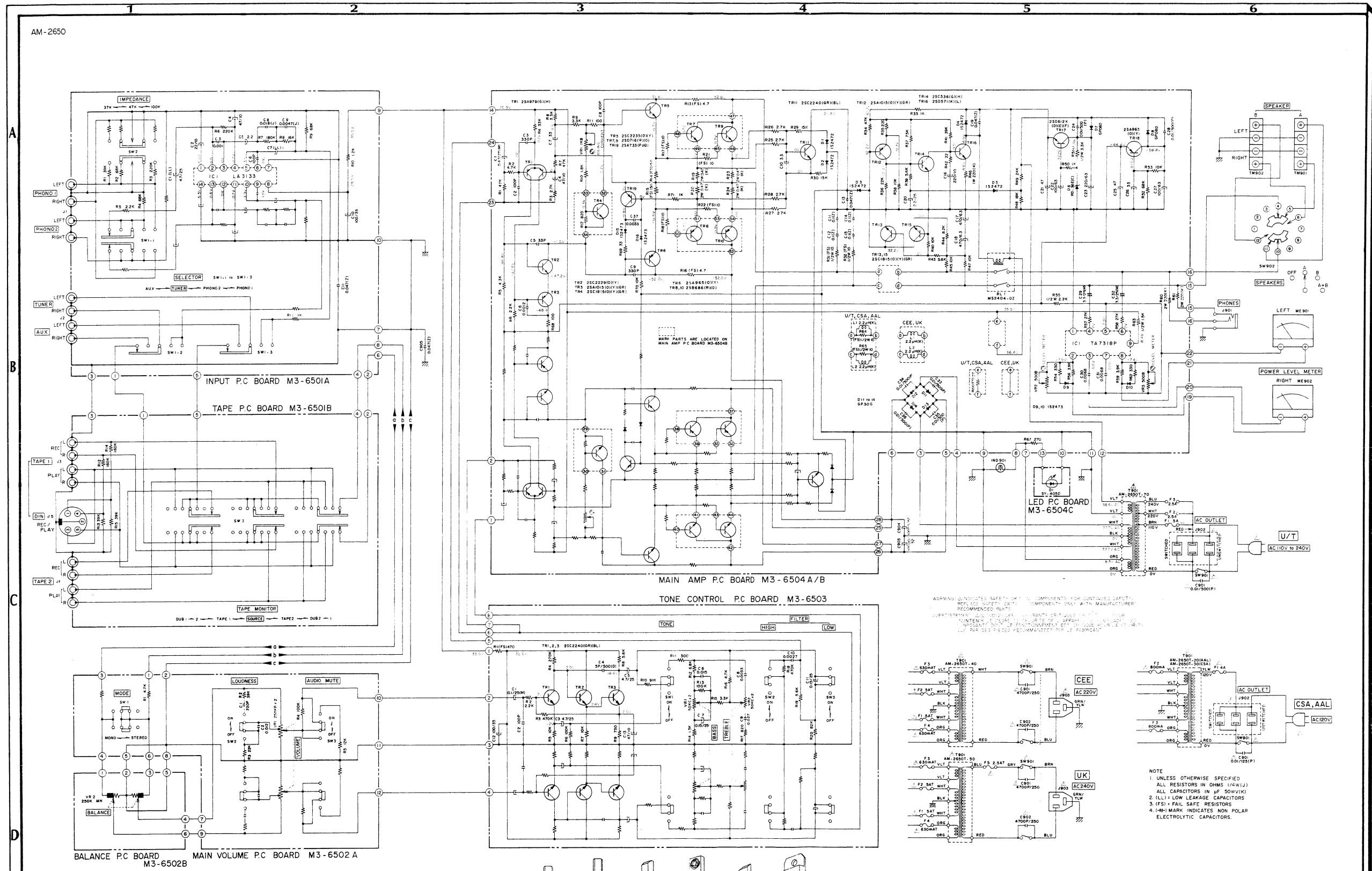

NOTE
 1. UNLESS OTHERWISE SPECIFIED
 ALL RESISTORS IN OHMS (4W/1/2)
 ALL CAPACITORS IN μ F 50V(1K)
 2. (L) LOW LEAKAGE CAPACITORS
 3. (FS) FAIL SAFE RESISTORS
 4. (-) MARK INDICATES NON POLAR
 ELECTROLYTIC CAPACITORS

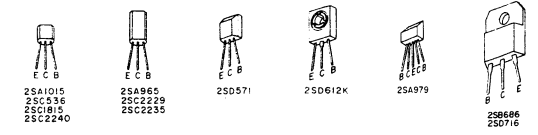

AM-2650
 SCHEMATIC DIAGRAM
 NO. 2-2 1562447A

AT-2650

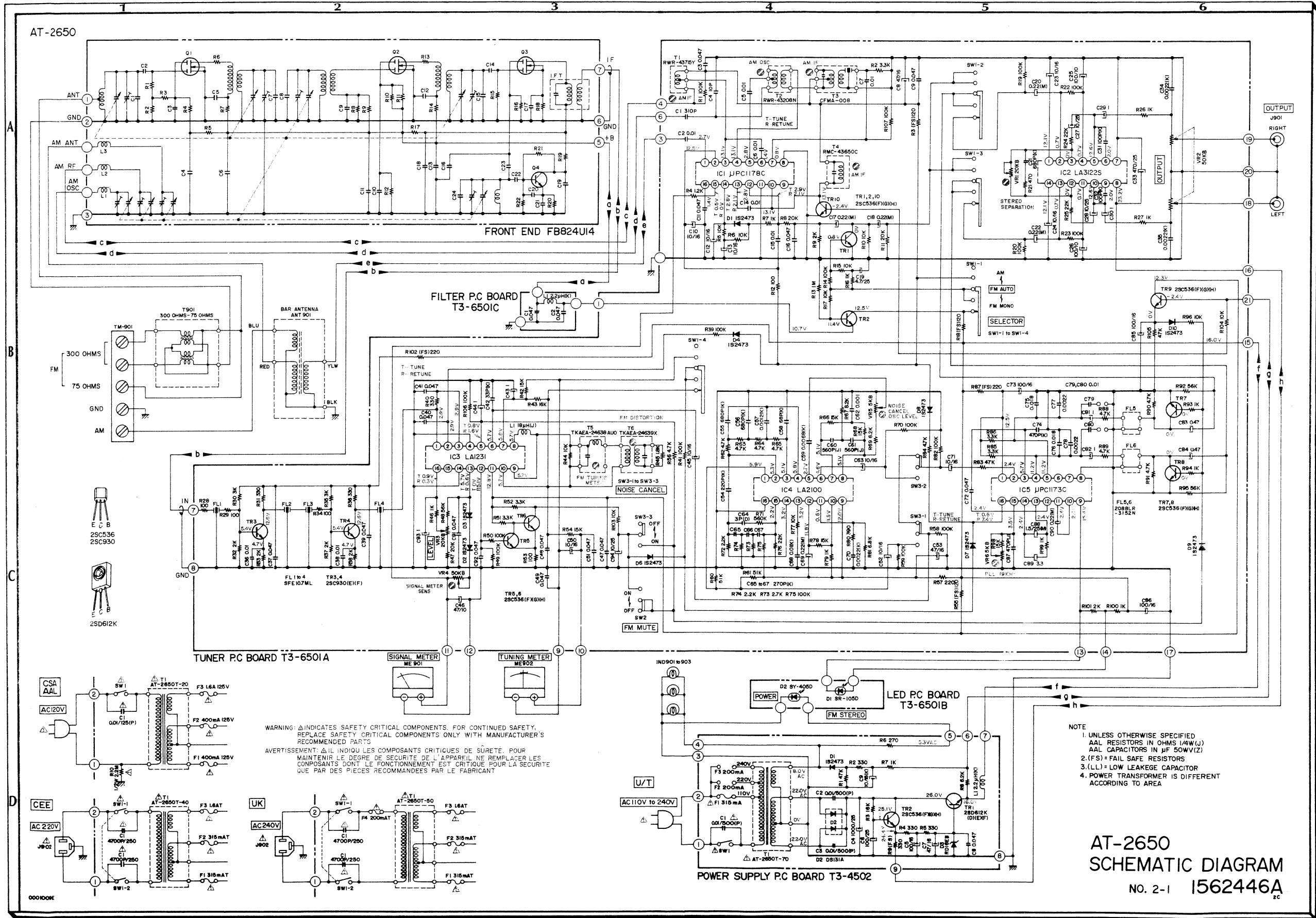

WARNING: Δ INDICATES SAFETY CRITICAL COMPONENTS. FOR CONTINUED SAFETY, REPLACE SAFETY CRITICAL COMPONENTS ONLY WITH MANUFACTURER'S RECOMMENDED PARTS.
 AVERTISSEMENT: Δ IL INDIQUE LES COMPOSANTS CRITIQUES DE SÛRETÉ. POUR MAINTENIR LE DEGRÉ DE SÛRETÉ DE L'APPAREIL, NE REMPLACER LES COMPOSANTS DONT LE FONCTIONNEMENT EST CRITIQUE POUR LA SÛRETÉ QUE PAR DES PIÈCES RECOMMANDÉES PAR LE FABRICANT.

- NOTE
1. UNLESS OTHERWISE SPECIFIED ALL RESISTORS IN OHMS (14W/1Z) AAL CAPACITORS IN μF 50WV(1Z)
 2. (FS) = FAIL SAFE RESISTORS
 3. (LL) = LOW LEAKAGE CAPACITOR
 4. POWER TRANSFORMER IS DIFFERENT ACCORDING TO AREA

AT-2650
 SCHEMATIC DIAGRAM
 NO. 2-1 1562446A