

# AKAI SERVICE MANUAL

*RTV servis Horvat*

Kešinci, 31402 Semeljci

Tel : 031-856-637

Tel / fax : 031-856-139

Mob : 098-788-319

[rtv-servis-horvat@os.tel.hr](mailto:rtv-servis-horvat@os.tel.hr)

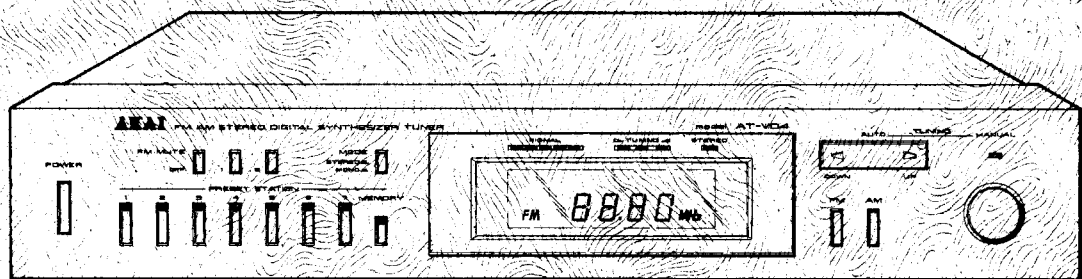
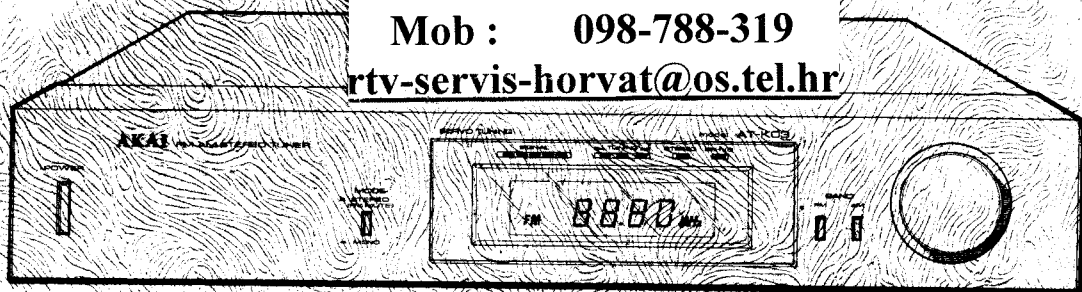

FM AM STEREO TUNER

**MODEL AT-K03**

FM AM STEREO DIGITAL SYNTHESIZER TUNER

**MODEL AT-V04/L**

# I. TECHNICAL DATA

## FM TUNER SECTION

FREQUENCY RANGE	87.5 MHz to 108 MHz
SENSITIVITY (IHF)	1.9 $\mu$ V
CAPTURE RATIO	1.2 dB
SELECTIVITY	More than 65 dB
IMAGE REJECTION	More than 60 dB (98 MHz)
IF REJECTION	More than 85 dB (98 MHz)
SPURIOUS REJECTION	More than 85 dB (98 MHz)
AM SUPPRESSION	60 dB
SIGNAL TO NOISE RATIO	73 dB
HARMONIC DISTORTION	
MONO	Less than 0.09% (100% modulation)
STEREO	Less than 0.12% (100% modulation)
STEREO SEPARATION	More than 52 dB (1 kHz)
SUB CARRIER SUPPRESSION	More than 60 dB
OUTPUT VOLTAGE	Fixed 1 V (100% modulation)
ANTENNA INPUT IMPEDANCE	300 ohms balanced, 75 ohms unbalanced

## AM TUNER SECTION

FREQUENCY RANGE	520 kHz to 1,605 kHz
SENSITIVITY (IHF)	150 $\mu$ V/m (bar antenna) 10 $\mu$ V (external antenna)
SELECTIVITY (IHF)	More than 30 dB
IMAGE REJECTION	More than 55 dB (1,000 kHz)
IF REJECTION	More than 40 dB
SIGNAL TO NOISE RATIO	More than 55 dB
OUTPUT VOLTAGE	300 mV (30% modulation)
ANTENNA	Built-in ferrite bar antenna
POWER REQUIREMENTS	120 V, 60 Hz for USA and Canada 220 V, 50 Hz for Europe except UK 240 V, 50 Hz for UK and Australia 110 V/220 V/240 V, 50/60 Hz internally switchable for other countries.
DIMENSIONS	440 (W) x 78 (H) x 340 (D) mm (17.3 x 3.1 x 13.4) inches
WEIGHT	4.9 kg (10.8 lbs)
POWER CONSUMPTION	20 W

\* For improvement purposes, specifications and design are subject to change without notice.

# VI. ADJUSTMENT

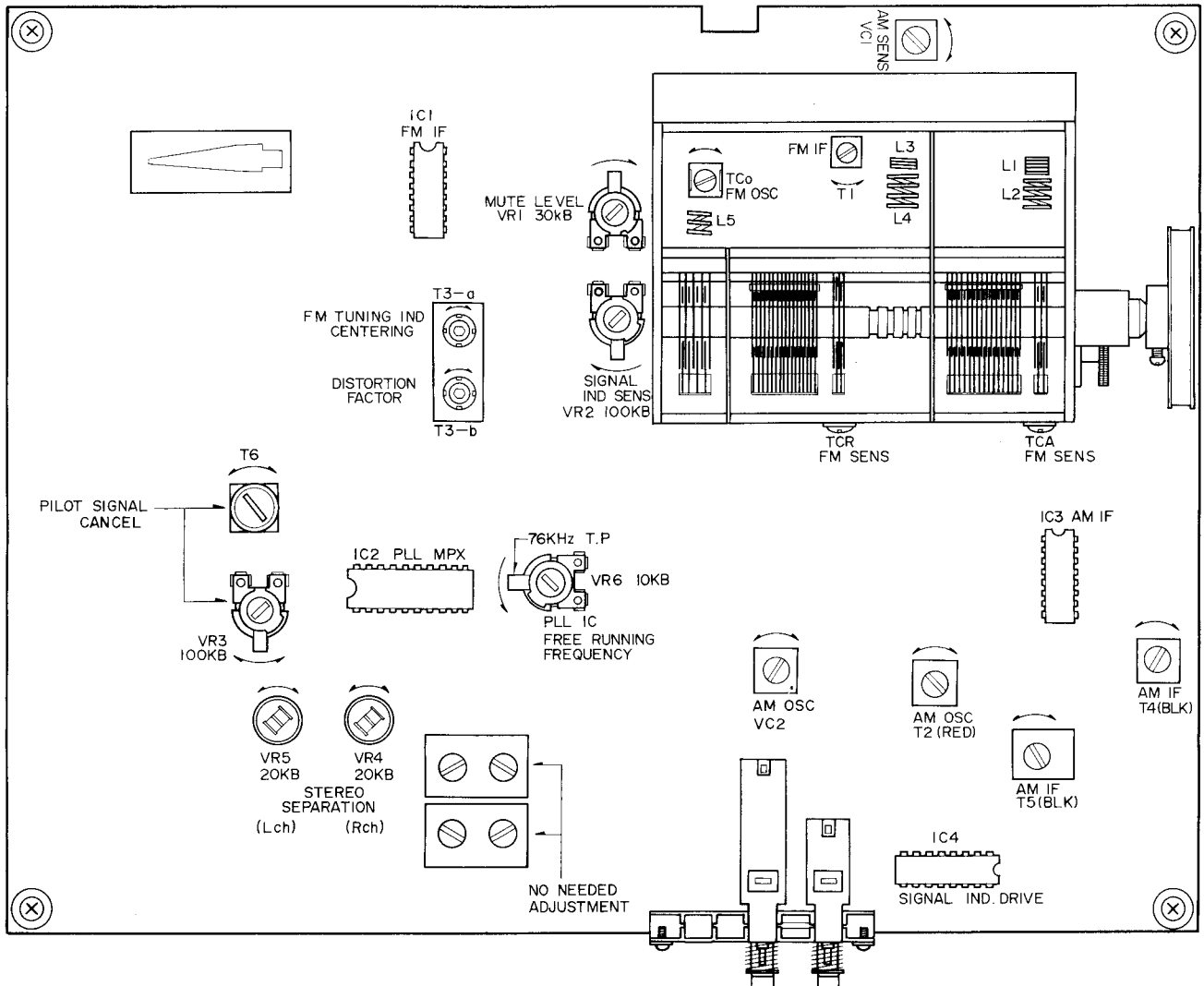

Fig. 5 Tuner P.C Board ATK-2001A

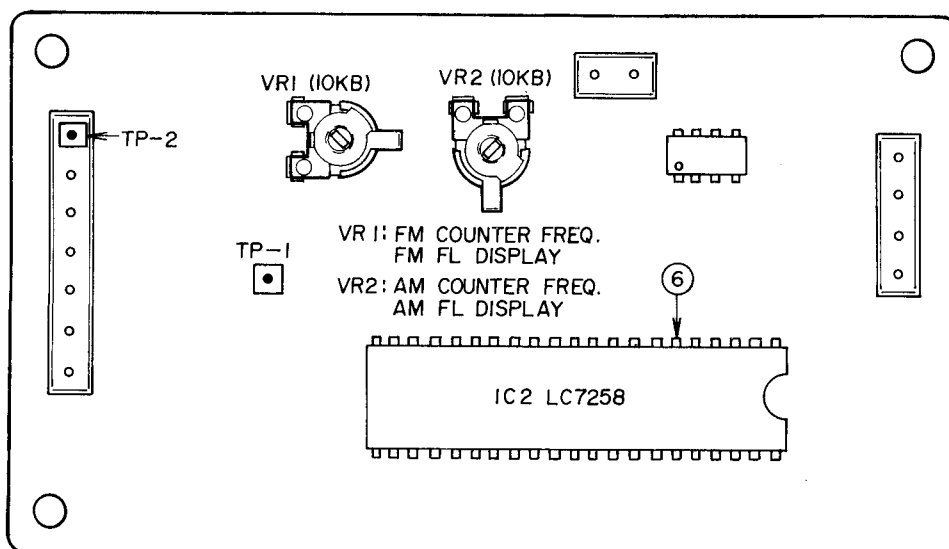

Fig. 6 FLD P.C Board (A) ATV-4008

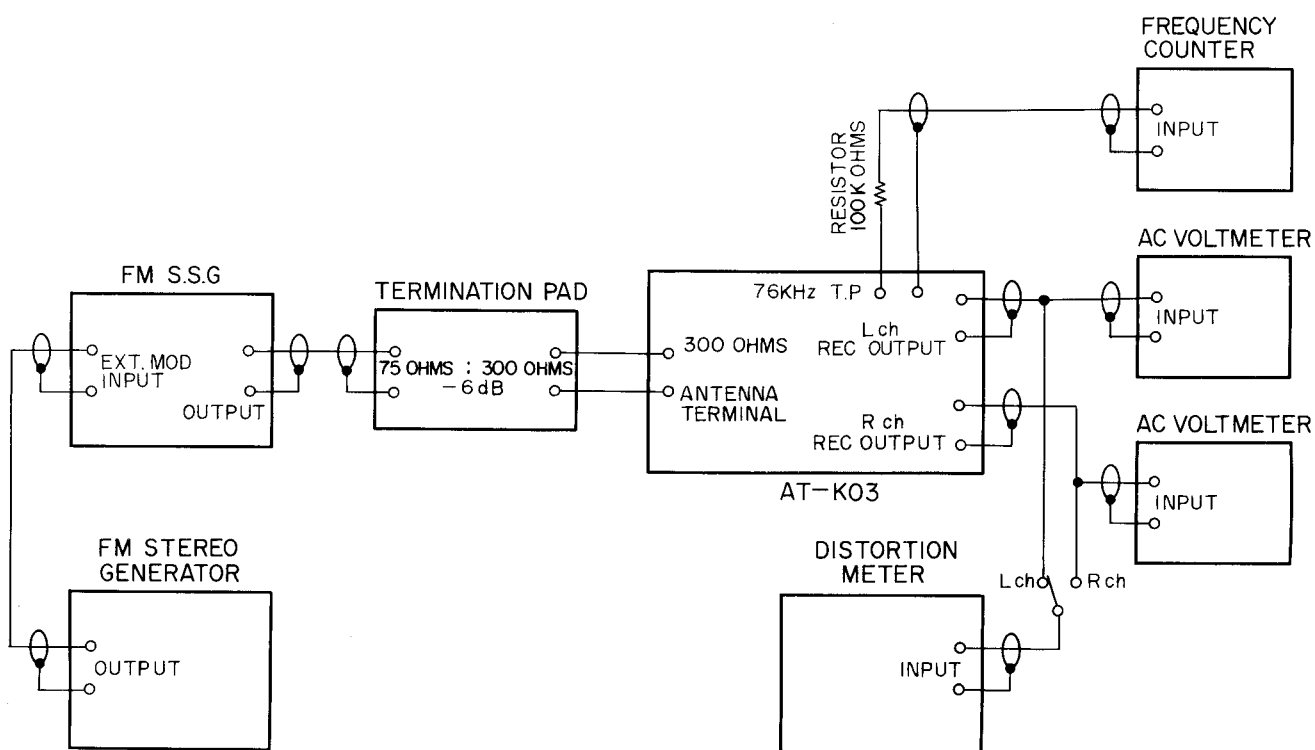

Fig. 7 Instrument Connections

## ***RTV servis Horvat***

**Kešinci, 31402 Semeljci**

**Tel : 031-856-637**

**Tel / fax : 031-856-139**

**Mob : 098-788-319**

**[rtv-servis-horvat@os.tel.hr](mailto:rtv-servis-horvat@os.tel.hr)**

**1. FM SECTION ADJUSTMENT (Refer to Figs. 5, 6 and 7)**

Step	Adjustment Item	Adjustment Point	Result	Remarks
1	Front End IF Coil	T1 Front End	Maximum noise level	BAND to "FM", and MODE to "MONO". Detune from broadcast and receive noise only.
2	Tuning Indicator Centering	T3-a	Center indication of tuning LEDs	98 MHz, 60 dB (mono) input.
3	Distortion Factor	T3-b	Distortion Factor: less than 0.09 %	98MHz, 60 dB (mono) input. Minimize distortion factor.
4	Confirmation of Tuning Indicator Centering			If tuning indicator is not centered, readjust Steps 2 and 3 described above.
5	FL Display Frequency	VR1 FLD P.C.B (A) ATV-4008	98.00 MHz Tune by centering LED and minimum distortion factor.	98MHz, 60 dB (mono) input. Ground TP2 on FL P.C. Board and adjust VR1 so that display shows 98.00 MHz and 4th numeral display must be stable. After completion, remove grounding.
6	High Range Display Indication	TC0 Front End	Maximum output Minimum distortion factor.	108.2 MHz, 60 dB (mono) input. Turn TUNING KNOB fully clockwise. Display to 108.20 MHz by adjusting TC0.
7	Confirmation of Low Range Display Indication		Maximum output Minimum distortion factor 88.0 ± .25 MHz	88 MHz, 60 dB (mono) input. Confirm whether display show 88.0 MHz. Error 250 kHz.
8	High Range Sensitivity	TCR, TCA Front End	Distortion Factor: less than 3 %	108 MHz, 6 dB or less (mono) input.
9	Confirmation of Low Range Sensitivity		Distortion Factor: less than 3 %	88 MHz, 6 dB or less (mono) input. Refer to NOTES 2 and 3.
10	Muting Level	VR1 30 kB ATK-2001A	No signal emitted from OUTPUT	MODE to "STEREO". 98 MHz, 22 dB (mono) input.
11	PLL IC Free Running Frequency	VR6 10 kB ATK-2001A	76.00 kHz	Frequency Counter to Test Point, Detuned condition. Refer to NOTES 4 and 5.
12	Confirmation of STEREO Indicator Lighting		Must be lighted	98 MHz, 60 dB (stereo) input. MODE to "STEREO".
13	Pilot Signal Cancel	VR3 100 kB L6 ATK-2001A	Minimum output	98 MHz, 60 dB (stereo) input. SSG modulated by only pilot signal, 19 kHz.

14	Stereo Separation (Left to Right)	VR5 20 kΩ ATK-2001A	More than 52 dB	98 MHz, 60 dB (stereo) input. SSG modulated 1 kHz, Rch, 100 %.
15	Stereo Separation (Right to Left)	VR4 20 kΩ ATK-2001A	More than 52 dB	98 MHz, 60 dB (stereo) input. SSG modulated 1 kHz, Lch, 100 %.
16	Signal Indicator Sensitivity	VR2 100 kΩ ATK-2001A	All LED light up.	98 MHz, 50 dB (mono) input. Adjust VR2 to a point where 5th LED of SIGNAL indicator lights up. Refer to NOTE 6.

Chart-1

- NOTES:
1. Set the FM ANTENNA ATT. switch to DIST.
  2. When the specified sensitivity of 6 dB cannot be obtained at the two frequency points, 88 MHz and 108 MHz repeat adjustment as in Step 7.
  3. When the distortion factor of the sensitivity still does not comply with the data specifications, adjust by turning the Front End FM IF coil (T1) core but not more than 1/2 turns.
  4. When connecting a frequency counter, connect from TP via a 100 Kohms resistor.
  5. The free Running Frequency of the PLL IC must be an exactly 76.00 kHz.
  6. The 5th LED lights up at 50 dB but when the attenuator is decreased 2 dB it is extinguished.

## 2. AM SECTION ADJUSTMENT (Refer to Figs. 5, 6, 7 and 8)

BAR ANTENNA CORE

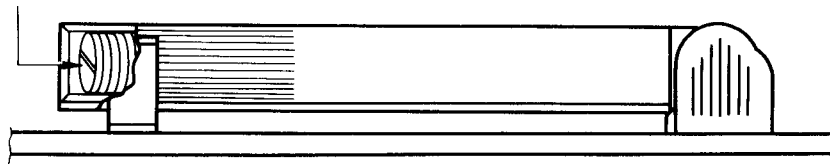

Fig. 8 Bar Antenna

Step	Adjustment Item	Adjustment Point	Result	Remarks
1	FL Display Frequency	VR2 FLD P.C.B. ATV-4008	Maximum output Minimum distortion	BAND to "AM" 1,000 kHz, 50 dB input. Ground TP2 and TP1 on FL P.C. Board, and adjust VR2 so that Display shows 1,000 and 4th numeral must be stable. After completion of adjustment disconnect grounding.
2	Low Range Display Indication	T2 (RED) ATK-2001A	Maximum output Minimum distortion	515 kHz, 50 dB input. Display to 515 kHz by adjusting T2.
3	Low Range Sensitivity	T4 (BLK) T5 (BLK) Bar Ant.	Maximum output Minimum distortion	530 kHz, 50 dB input. Distortion factor: 10% or less. Refer to Fig. 5.
4	High Range Display Indication	VC2 ATK-2001A	Maximum output	1620 kHz, 50 dB input. Display to 1620 kHz by adjusting VC2.
5	High Range Sensitivity	VC1 ATK-2001A	Maximum output Minimum distortion	1600 kHz, 50 dB input. Distortion factor: 10 % or less.

Chart-2

NOTE: For the best results, repeat Steps 2 through 5 two or three times.

---

SECTION 2

**MODEL AT-V04/L**  
**SERVICE MANUAL**

TABLE OF CONTENTS

I.	TECHNICAL DATA .....	18
II.	DISMANTLING OF UNIT .....	19
III.	CONTROLS .....	20
IV.	PRINCIPAL PARTS LOCATION .....	21
V.	VOLTAGE CONVERSION .....	23
VI.	ADJUSTMENT .....	24
	1. SYNTHESIZER SECTION ADJUSTMENT .....	27
	2. AM (MW AT-K04/L) SECTION ADJUSTMENT .....	28
	3. LW SECTION ADJUSTMENT .....	29
	4. FM SECTION ADJUSTMENT .....	30
VII.	CLASSIFICATION OF VARIOUS P.C BOARDS .....	32
	1. P.C BOARD TITLES AND IDENTIFICATION NUMBERS .....	32
	2. COMPOSITION OF VARIOUS P.C BOARDS .....	33

For basic adjustments, measuring methods, and operating principles, refer to GENERAL TECHNICAL MANUAL.

# I. TECHNICAL DATA

## FM TUNER SECTION

FREQUENCY RANGE	87.5 MHz to 108 MHz
SENSITIVITY (IHF)	1.6 $\mu$ V
CAPTURE RATIO	1.2 dB
SELECTIVITY (IHF)	More than 75 dB
IMAGE REJECTION	More than 80 dB (98 MHz)
IF REJECTION	More than 95 dB (98 MHz)
SPURIOUS REJECTION	More than 95 dB (98 MHz)
AM SUPPRESSION	65 dB
SIGNAL TO NOISE RATIO	75 dB
HARMONIC DISTORTION	
MONO	Less than 0.08% (100% modulation)
STEREO	Less than 0.1% (100% modulation)
MUTING	OFF
	1. 30 $\mu$ V
	2. 10 $\mu$ V to 100 $\mu$ V
STEREO SEPARATION	More than 54 dB (1 kHz)
SUB CARRIER SUPPRESSION	More than 80 dB
OUTPUT VOLTAGE	Controllable from 0 to 1.5 V (100% modulation)
ANTENNA INPUT IMPEDANCE	300 ohms balanced, 75 ohms unbalanced

## AM TUNER SECTION

### MW

FREQUENCY RANGE	520 kHz to 1,605 kHz
SENSITIVITY (IHF)	150 $\mu$ V/m (bar antenna), 10 $\mu$ V (external antenna)
SELECTIVITY (IHF)	More than 30 dB
IMAGE REJECTION	More than 55 dB (1,000 kHz)
IF REJECTION	More than 40 dB
SIGNAL TO NOISE RATIO	More than 55 dB
OUTPUT VOLTAGE	Controllable from 0 mV to 500 mV (30% modulation)

### LW (AT-V04L only)

FREQUENCY RANGE	135 kHz to 355 kHz
SENSITIVITY (IHF)	200 $\mu$ V/m (bar antenna), 17 $\mu$ V (external antenna)
SELECTIVITY (IHF)	More than 30 dB
IMAGE REJECTION	More than 50 dB (200 kHz)
IF REJECTION	More than 40 dB
SIGNAL TO NOISE RATIO	More than 55 dB
OUTPUT VOLTAGE	Controllable from 0 mV to 500 mV (30% modulation)

### ANTENNA

POWER REQUIREMENTS	Built-in ferrite bar antenna 120 V, 60 Hz for USA and Canada 220 V, 50 Hz for Europe except UK 240 V, 50 Hz for UK and Australia 110 V/220 V/240 V, 50/60 Hz internally switchable for others.
--------------------	------------------------------------------------------------------------------------------------------------------------------------------------------------------------------------------------------------

### POWER CONSUMPTION

	20 W
--	------

### DIMENSIONS

	440 (W) x 78 (H) x 332 (D) mm
--	-------------------------------

	(17.3 x 3.1 x 13.1) inches
--	----------------------------

### WEIGHT

	5.5 kg
--	--------

	(12.1 lbs)
--	------------

\* For improvement purposes, specifications and design are subject to change without notice.



# VI. ADJUSTMENT

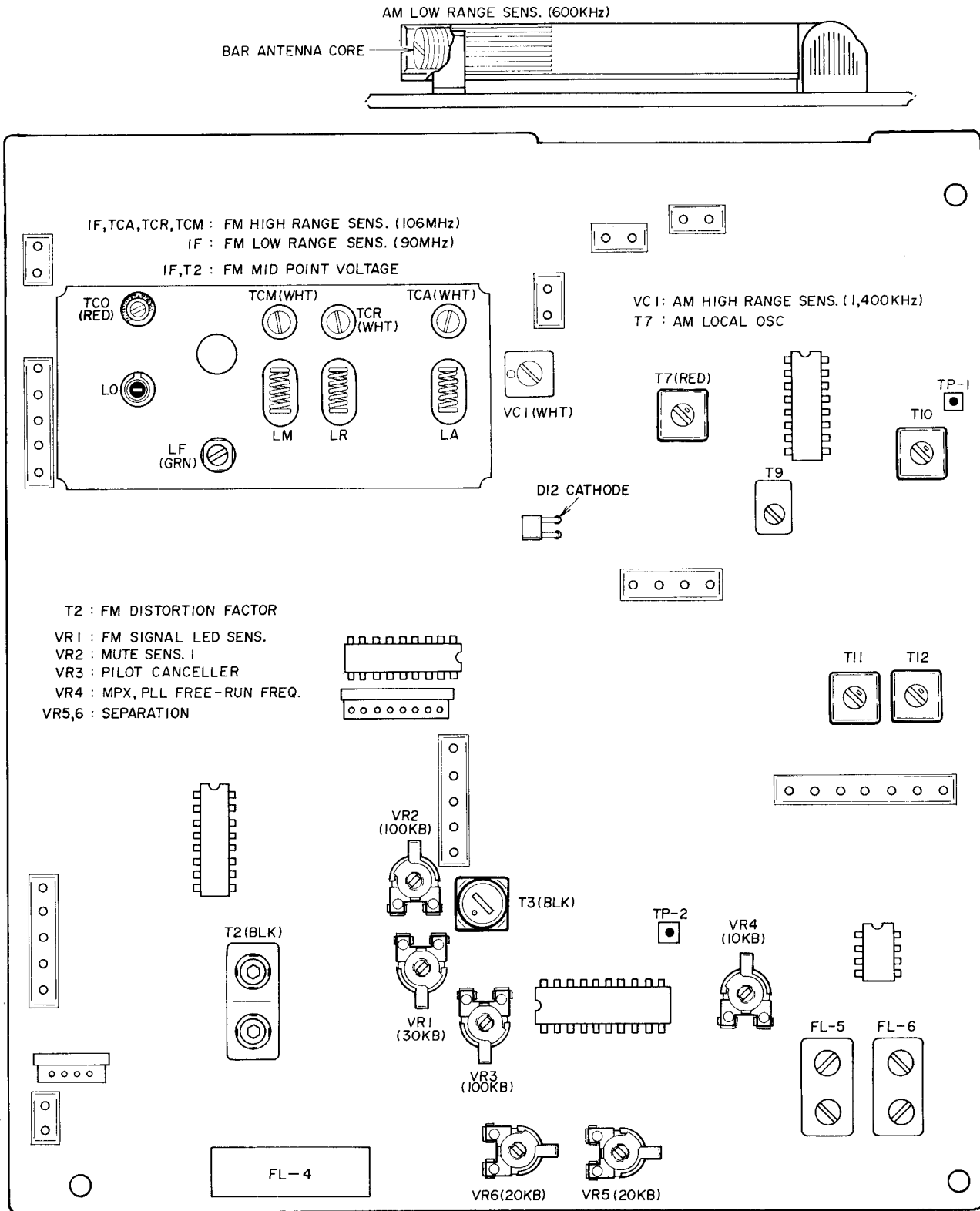

Fig. 5 Tuner P.C Board ATV-4001A (AT-V04)

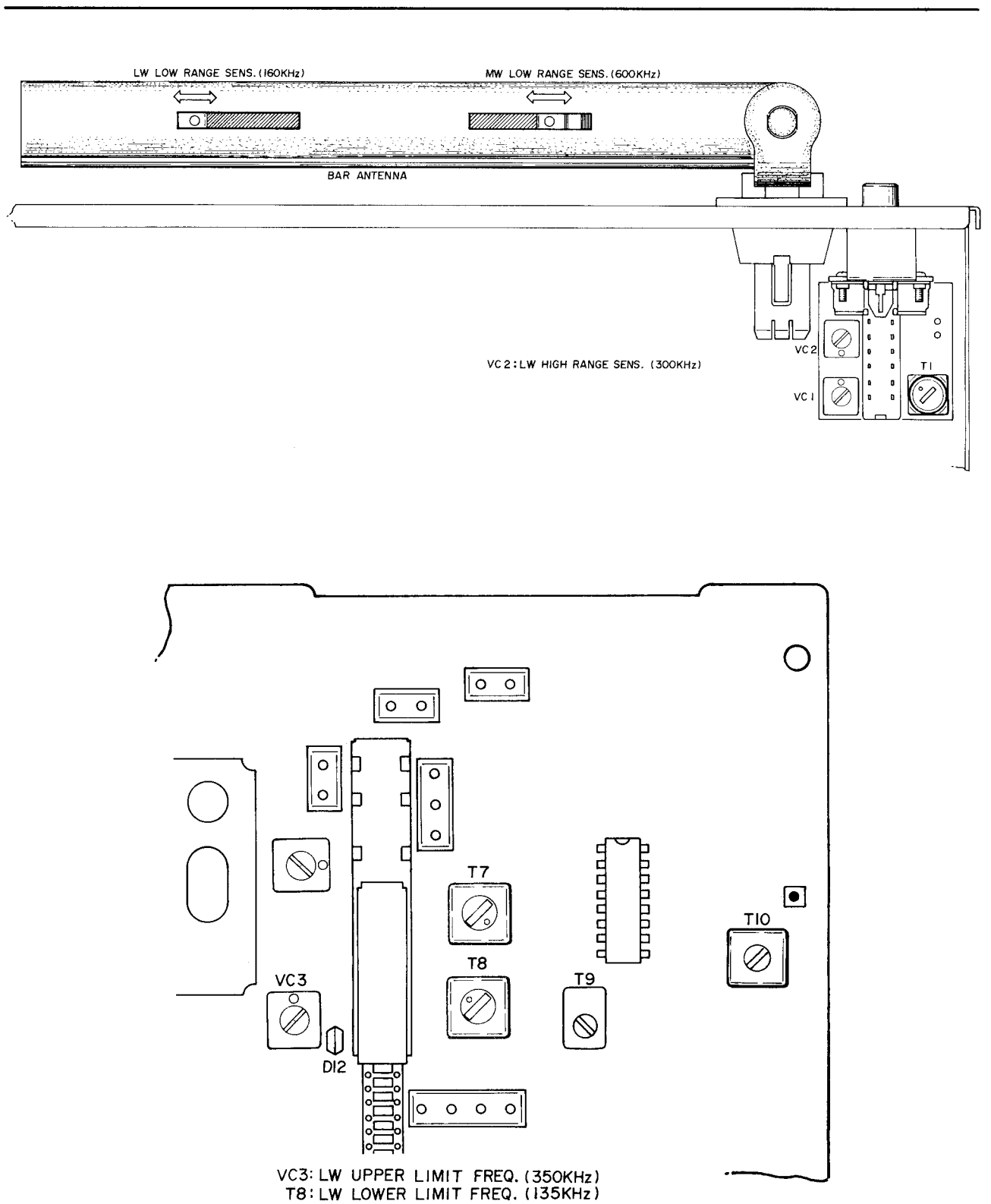

Fig. 6 Tuner P.C Board ATV-4001A and ANT Switch P.C Board ATV-2063 (AT-V04L)

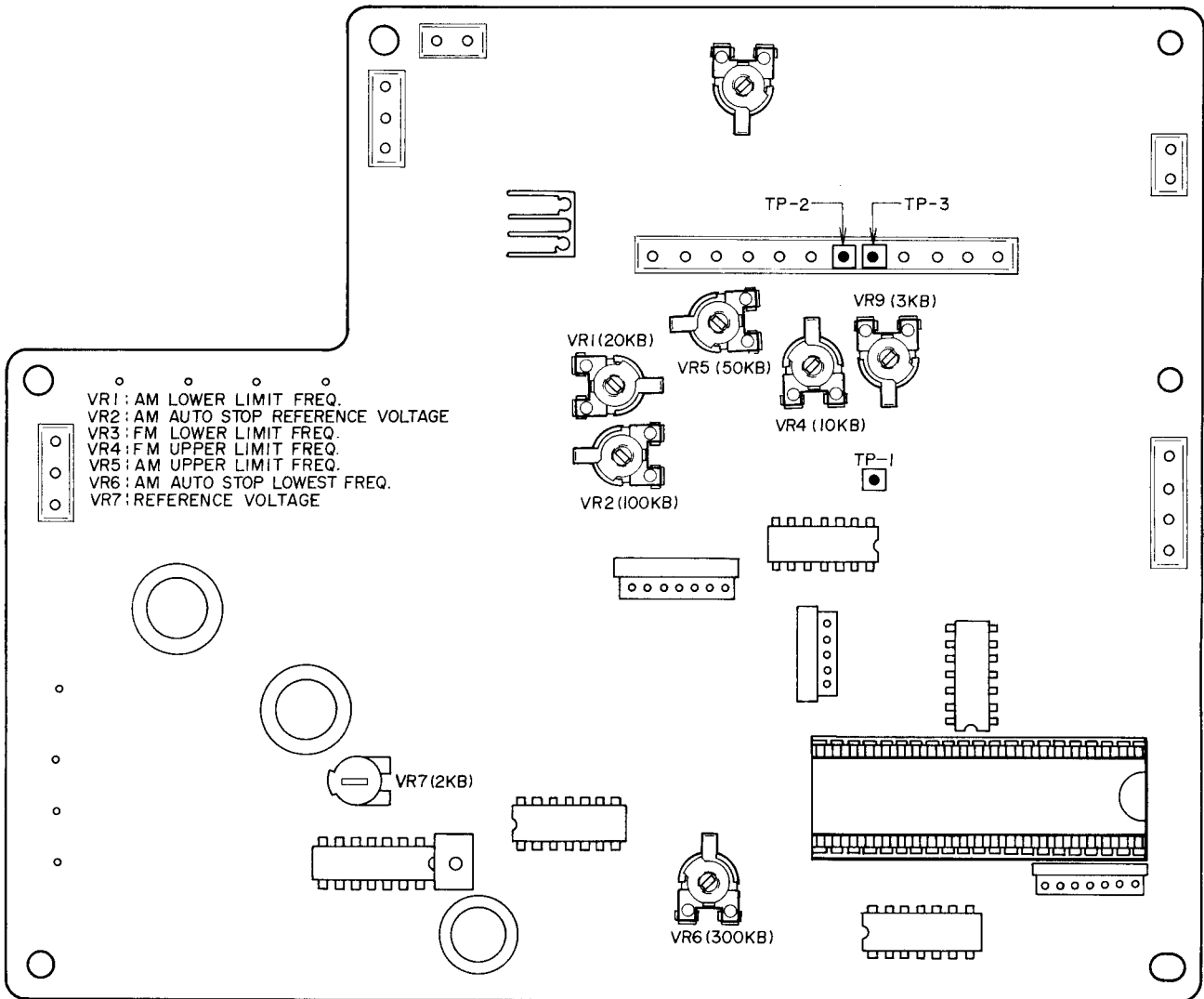

Fig. 7 Synthesizer P.C Board ATV-4002

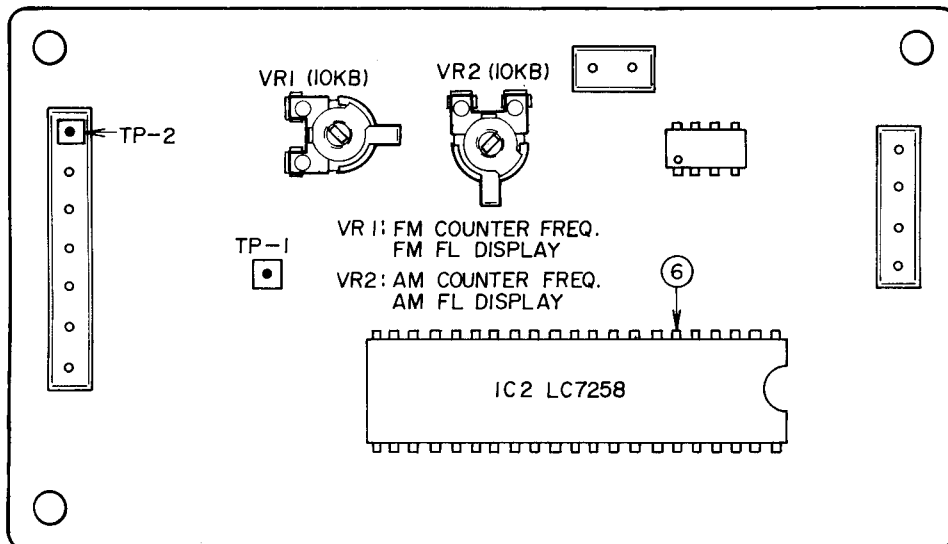

Fig. 8 FLD P.C Board ATV-4008

## 1. SYNTHESIZER SECTION ADJUSTMENT (Refer to Figs. 5, 7 and 8)

Step	Adjustment Item	Test Point	Adjustment Parts	Result and Remarks
1	Reference Voltage	TP-2 (ATV-4002)	VR7 (2 kB) (ATV-4002)	Adjust VR7 (2 kB) so that the voltage at TP-2 become $8.0 \pm 0.2$ V. (VTVM)
2	FM Upper Limit Frequency	⑥ Pin of IC2 (LC7258) (ATV-4008)	VR4 (10 kB) (ATV-4002)	<ol style="list-style-type: none"> <li>1) Set Band Selector Switch to "FM".</li> <li>2) Turn Tuning Knob fully clockwise.</li> <li>3) Adjust VR4 (10 kB) so that the counter reads 1,189 kHz [<math>108.2 \text{ MHz (FL Display) + } 10.7 \text{ MHz} \div 100 = 1.189 \text{ MHz}</math> (Freq. Counter)]</li> </ol>
3	FM Counter Frequency	FL Display	VR1 (10 kB) (ATV-4008)	<ol style="list-style-type: none"> <li>1) Set Band Selector Switch to "FM".</li> <li>2) Turn Tuning Knob fully clockwise.</li> <li>3) Adjust VR1 (10 kB) so that FL Display shows 108.20 MHz.</li> </ol>
4	AM Local OSC	⑥ Pin of IC2 (LC7258) (ATV-4008)	T7 (RED) (ATV-4001A)	<ol style="list-style-type: none"> <li>1) Set Band Selector switch to "AM" ("MW" AT-K04L).</li> <li>2) Short cathode side of D12 (ATV-4001A) to ground.</li> <li>3) Adjust T7 (RED) so that the counter reads <math>710 \pm 1</math> kHz. (Freq. Counter)</li> </ol>
5	AM Counter Frequency	FL Display	VR2 (10 kB) (ATV-4008)	<ol style="list-style-type: none"> <li>1) Set Band Selector Switch to "AM".</li> <li>2) Short cathode side of D12 (ATV-4001A) to ground.</li> <li>3) Adjust VR2 (10 kB) so that FL Display shows 240 kHz.</li> </ol>
6	AM Upper Limit Frequency	FL Display	VR5 (50 kB) (ATV-4002)	<ol style="list-style-type: none"> <li>1) Set Band Selector Switch to "AM" ("MW" AT-K04L).</li> <li>2) Turn Tuning Knob fully clockwise.</li> <li>3) Adjust VR5 (50 kB) so that FL Display shows 1,620 kHz.</li> </ol>
7	AM Lower Limit Frequency	FL Display	VR1 (20 kB) (ATV-4002)	<ol style="list-style-type: none"> <li>1) Set Band Selector Switch to "AM" ("MW" AT-K04L).</li> <li>2) Turn Tuning Knob counter-clockwise fully.</li> <li>3) Adjust VR1 (20 kB) so that FL Display shows 515 kHz.</li> </ol>
8	FM Lower Limit Frequency	FL Display	VR9 (3 kB) (ATV-4002)	<ol style="list-style-type: none"> <li>1) Set Band Selector Switch to "FM".</li> <li>2) Turn Tuning Knob counter-clockwise fully.</li> <li>3) Adjust VR9 (3 kB) so that FL Display shows 87.40 MHz.</li> </ol>

Step	Adjustment Item	Test Point	Adjustment Parts	Result and Remarks
9	AM Auto Stop Lowest Frequency	FL Display	VR6 (300 kB) (ATV-4002)	<ol style="list-style-type: none"> <li>1) Set Band Selector Switch to "AM" ("MW" AT-K04L).</li> <li>2) Short TP-3 (ATV-4002) to ground.</li> <li>3) FL Display will show approx. 400 kHz.</li> <li>4) Memorise this display to a certain "PRESET SECTION".</li> <li>5) Disconnect Step 3).</li> <li>6) Adjust VR6 (300 kB) so that the FL Display which recalled from memory becomes 515 kHz.</li> </ol>
10	AM Auto Stop Reference Voltage	TP-2 (ATV-4002)	VR2 (100 kB) (ATV-4002)	<ol style="list-style-type: none"> <li>1) Set to Band Selector Switch to "AM" ("MW" AT-K04L).</li> <li>2) No signal input.</li> <li>3) Adjust VR2 (100 kB) so that voltage at TP-2 is <math>4.75 \pm 0.5</math> V. (VTVM)</li> </ol>

## 2. AM (MW AT-K04L) SECTION ADJUSTMENT (Refer to Figs. 5 to 8)

Step	Adjustment Item	Test Point	Adjustment Parts	Result and Remarks
1	Low Range Sensitivity (600 kHz)	Output	Bar Antenna Core	<ol style="list-style-type: none"> <li>1) Set FL Display to 600 kHz.</li> <li>2) Feed a signal of 600 kHz, 30% modulation, 20 dB from SSG to Ant Input.</li> <li>3) Increase the ATT of SSG and adjust the core so that the sensitivity at 10 % distortion factor obtains 45 dBm or less. (Distortion meter, SSG)</li> </ol>
2	High Range Sensitivity (1,400 kHz)	Output	VC1 (WHT) (ATV-4001A)	Adjust the sensitivity at 1,400 kHz by the same as step 1.
3	Mid Range Sensitivity (1,000 kHz)	Output	Confirm	Check the sensitivity at 1,000 kHz by the same as step 1.
4	Auto Stop Sensitivity	FL Display SSG's ATT	Confirm	<ol style="list-style-type: none"> <li>1) Feed a 1,000 kHz, 65 dB from SSG to Ant Input.</li> <li>2) Operate the Auto Scan and check auto stop position by the FL Display indicates 1,000 kHz. (SSG)</li> </ol>
5	Output Level	Output	Confirm	<ol style="list-style-type: none"> <li>1) Feed a 1,000 kHz, 64 dB from SSG to Ant Input.</li> <li>2) Check the output level is within <math>-6.5 \text{ dBm} \pm 2 \text{ dB}</math>. (SSG, VTVM)</li> </ol>
6	FL Display Frequency	FL Display	VR2 (10 kB) (ATV-4008)	<ol style="list-style-type: none"> <li>1) Feed a 1 kHz to Ant Input and receive this signal.</li> <li>2) Short TP-1, TP-2 (on ATV-4008) to ground.</li> <li>3) Adjust VR2 (10 kB) until 4th numeral display become stable.</li> </ol>

### 3. LW SECTION ADJUSTMENT (AT-V04L only)

Step	Adjustment Item	Test Point	Adjustment Parts	Result and Remarks
1	Upper Limit Freq.	FL Display	VC3 (ATK-4001A)	1) Turn Tuning Knob fully clockwise. 2) Adjust VC3 so that FL Display shows 350 kHz.
2	Lower Limit Freq.	FL Display	T8 (RED) (ATK-4001A)	1) Turn Tuning Knob fully counter-clockwise. 2) Adjust T8 so that FL Display shows 135 kHz.
3	Low Range Sensitivity (160 kHz)	Output	Bar Antenna Core	1) Set FL Display to 160 kHz. 2) Feed a signal of 160 kHz, 30 % modulation, 20 dB from SSG to Ant Input. 3) Increase the ATT of SSG and adjust the core so that the sensitivity at 10 % distortion factor obtains 50 dBm or less. (Distortion meter, SSG)
4	High Range Sensitivity (300 kHz)	Output	VC2 (ATK-2063)	Adjust the Sensitivity at 300 kHz by the same as step 3.
5	Mid range Sensitivity (200 kHz)	Output	Confirm	Check the Sensitivity at 200 kHz by the same as step 3.
6	Auto Stop Level (INT Ant.)	FL Display	Confirm	1) Set the LW ANT Switch to "INT". 2) Feed a 200 kHz, 65 dB from SSG to Ant Input. 3) Operate the Auto Scan and check auto stop position by the FL Display indicates 200 kHz. (SSG)
7	Auto Stop Level (EXT Ant.)	FL Display	Confirm	1) Set the LW ANT Switch to "EXT". 2) Feed a 200 kHz, 45 dB from SSG to Ant Input. 3) Operate the Auto Scan and check auto stop position by the FL Display indicates 200 kHz. (SSG)

#### 4. FM SECTION ADJUSTMENT (Refer to Figs. 5, 7 and 8)

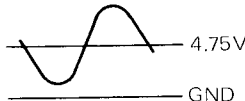
Step	Adjustment Item	Test Point	Adjustment Parts	Result and Remarks
1	Mid Point Voltage	TP-1 (ATV-4002)	IF (GRN) (Front End) T2 (BLK) (ATV-4001A)	<ol style="list-style-type: none"> <li>1) Feed 90 MHz, 60 dB from SSG to Ant Input.</li> <li>2) Obtain 2 maximum output by adjusting IF core.</li> <li>3) Adjust T2 (BLK) until the voltage at TP-1 is 4.75 V when "S" curve waveform is symmetry. (SSG, VTVM, Oscilloscope)</li> </ol> 
2	Distortion Factor	Output	T2 (BLK) (ATV-4001A)	Minimize the distortion factor (less than 0.1 %) under the condition is step 1.
3				Readjust in steps 1 and 2.
4	High Range Sensitivity (106 MHz)	Output	IF (GRN) TCA (WHT) TCR (WHT) TCM (WHT) (Front End)	<ol style="list-style-type: none"> <li>1) Input the 106 MHz Signal from the SSG into Ant Input.</li> <li>2) At the point where distortion factor is 3 %, adjust so that ATT of SSG is less than 6 dB. (SSG, Distortion meter)</li> </ol>
5	Low Range Sensitivity (90 MHz)	Output	IF (GRN) (Front End)	Input the 90 MHz Signal from the SSG into Ant Input, and adjust by the same as step 4-2).
6	Mid Range Sensitivity (98 MHz)	Output	Confirm	Check the sensitivity at 98 MHz by the same as step 4, and re-adjust in steps 4 to 6.
7	Mute Sensitivity (FM MUTE 1)	Output	VR2 (100 kB) (ATV-4001A)	<ol style="list-style-type: none"> <li>1) Set FM MUTE Switch to "1".</li> <li>2) Input the 98 MHz Signal from SSG to Ant Input.</li> <li>3) Adjust VR2 (100 kB) to the point where the Output Signal disappears at SSG's ATT 30 ± 3 dB. (SSG, VTVM)</li> </ol>
8	Mute Sensitivity (FM MUTE 2)	Output	VR1 (20 kB) (ATV-4006, Rear Panel)	<ol style="list-style-type: none"> <li>1) Set FM MUTE Switch to "2".</li> <li>2) Adjust by the same as step 7, that input level is approx. 15 to 30 dB in VR1 (20 kB) min to max. (SSG, VTVM)</li> </ol>
9	Signal LED Sensitivity	Signal LED	VR1 (30 kB) (ATV-4001A)	<ol style="list-style-type: none"> <li>1) Feed 98 MHz, 45 ± 5 dB from SSG to Ant Input.</li> <li>2) Adjust VR1 (30 kB) until the 5th LED is lighted. (SSG)</li> </ol>
10	MPX, PLL Free-run Frequency	TP-2 (ATV-4001A)	VR4 (10 kB) (ATV-4001A)	<ol style="list-style-type: none"> <li>1) No Signal input.</li> <li>2) Set MODE Switch to "STEREO".</li> <li>3) Adjust VR4 (10 kB) so that the counter reads 76 kHz ± 50 Hz. (Freq. Counter)</li> </ol>

Step	Adjustment Item	Test Point	Adjustment Parts	Result and Remarks
11	Pilot Cancellor	Output	VR3 (100 kB) T3 (BLK) (ATV-4001A)	<ol style="list-style-type: none"> <li>1) Feed a pilot signal (19 kHz, 10 %) from SSG to Ant Input.</li> <li>2) Adjust VR3 (100 kB) first so that output is minimum.</li> <li>3) Adjust T3 (BLK) so that the output level of L-ch and R-ch are balanced.</li> <li>4) Repeat steps 2) and 3) until output levels become 64 dB or less. (SSG, Distortion meter, VTVM)</li> </ol>
12	Separation	Output	VR5 (20 kB) VR6 (20 kB) (ATV-4001A)	<ol style="list-style-type: none"> <li>1) Connect 98 MHz, 60 dB stereo R-ch signal from SSG to Ant input.</li> <li>2) Adjust VR5 (20 kB) until R-ch output is maximum and L-ch output is minimum.</li> <li>3) Similarly, proceed for L-ch using VR6 (20 kB) as steps 1) and 2). (SSG, VTVM)</li> </ol>
13	Output Level	Output	VR2 (20 kBx2) (ATV-4006, Rear Panel)	<ol style="list-style-type: none"> <li>1) Feed a 98 MHz, 60 dB from SSG to Ant Input, and VR2 (20 kB x2, ATV-4006) to maximum position.</li> <li>2) Check the output level is 5.5 dBm <math>\pm</math> 2 dB.</li> </ol>
14	FL Display Frequency	FL Display	VR1 (10 kB) (ATV-4008)	<ol style="list-style-type: none"> <li>1) Feed a 98 MHz to Ant Input and receive this signal.</li> <li>2) Short TP-2 (ATV-4008) to ground.</li> <li>3) Adjust VR1 (10 kB) until 3rd numeral display become stable.</li> </ol>

## ***RTV servis Horvat***

**Kešinci, 31402 Semeljci**

**Tel : 031-856-637**

**Tel / fax : 031-856-139**

**Mob : 098-788-319**

**[rty-servis-horvat@os.tel.hr](mailto:rty-servis-horvat@os.tel.hr)**



SECTION 4

# SCHEMATIC DIAGRAM

1. SCHEMATIC DIAGRAM OF ICs
2. AT-K03 NO. 1601226A SCHEMATIC DIAGRAM
3. AT-V04,AT-V04L NO. 2-1 1601218A TUNER SCHEMATIC DIAGRAM
4. AT-V04,AT-V04L NO. 2-2 1601219A SYNTHESIZER SCHEMATIC DIAGRAM

MODEL AT-K03,AT-V04/L

LA1231, LA1231N

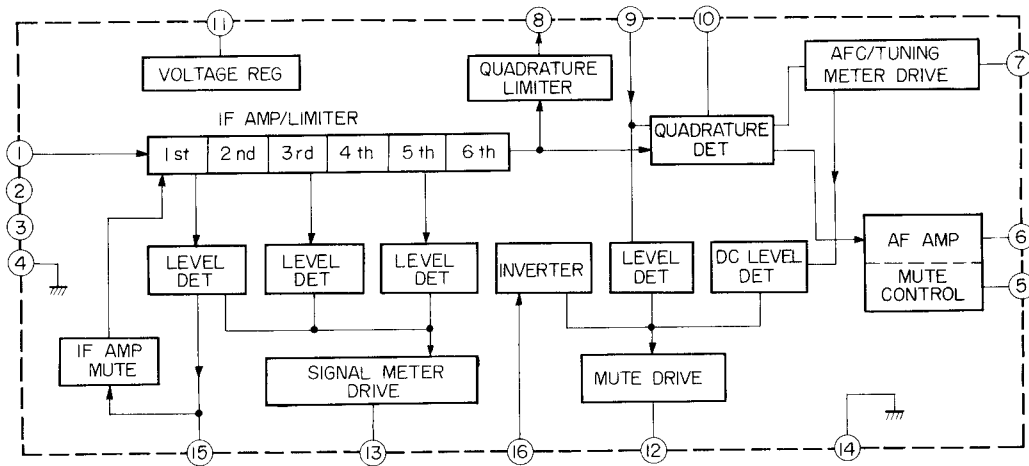

LA1240

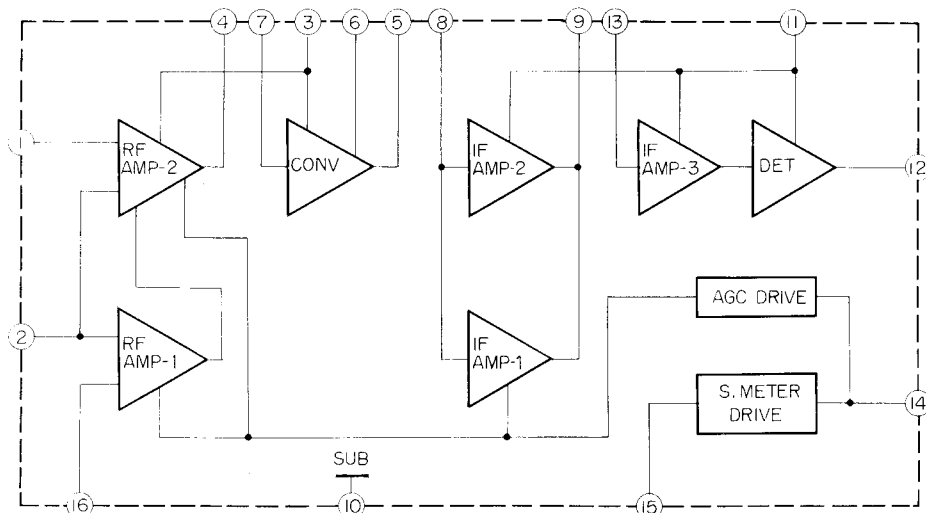

LA3380

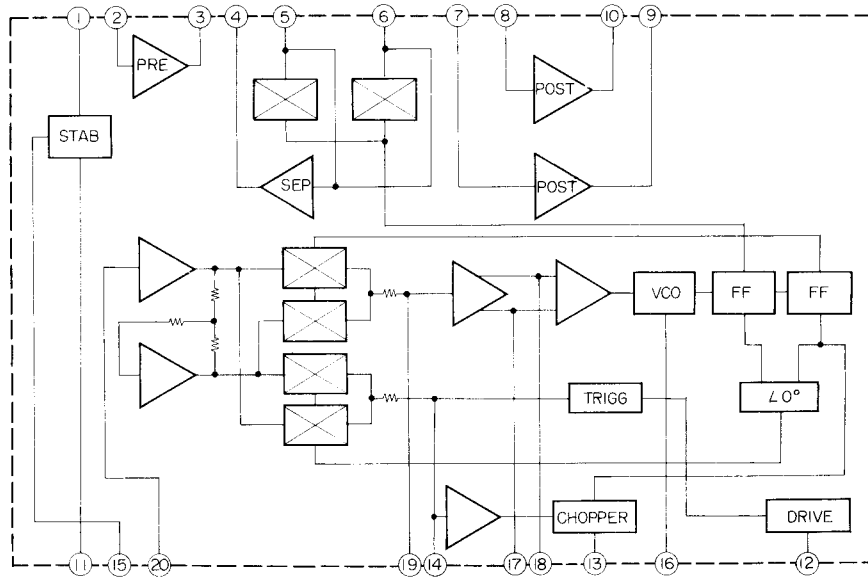

LB1405S

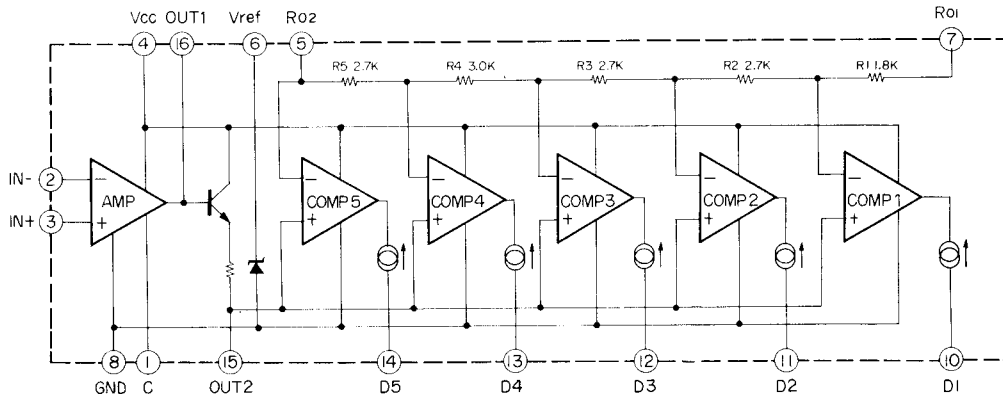

LC7258

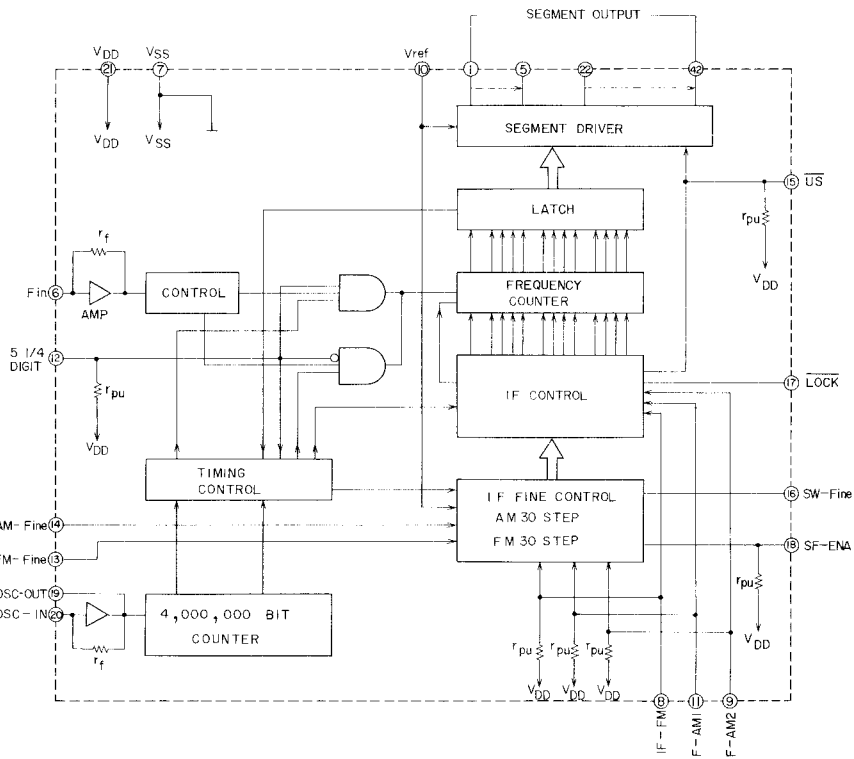

SP8629

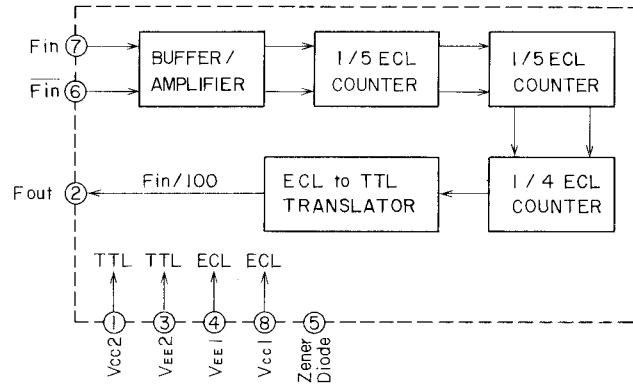

MODEL AT-V04/L

LA5700

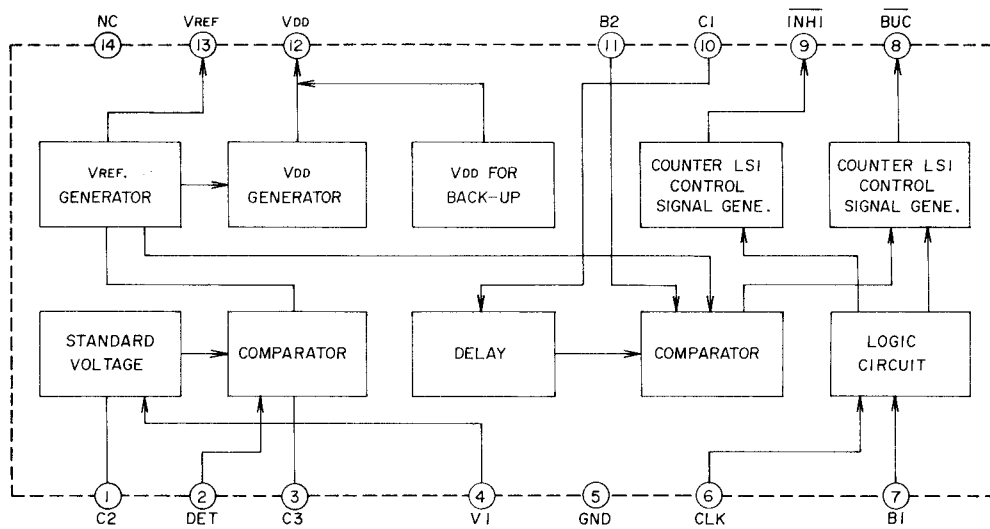

LOGIC CHART

BI	B2	CLK	Vdd	VREF	BUC	INH1	REMARK
L	H	L	≈5V	0V	L	L	AT BUCK-UP
H	H	L	≈9V	8V	H	H	RADIO "ON"
L	H	H	≈9V	8V	L	H	START THE TIME READING AT RADIO "OFF"
H	H	H	≈9V	8V	H	H	START THE TIME READING AT RADIO "ON"

TA7060P

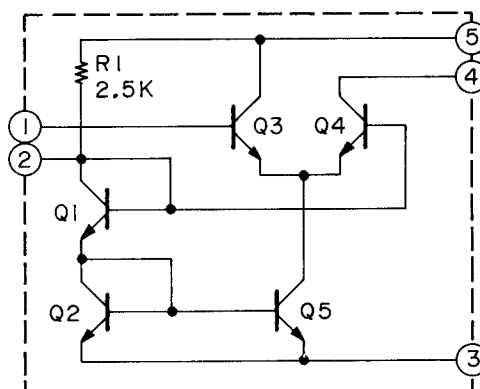

TA7324P

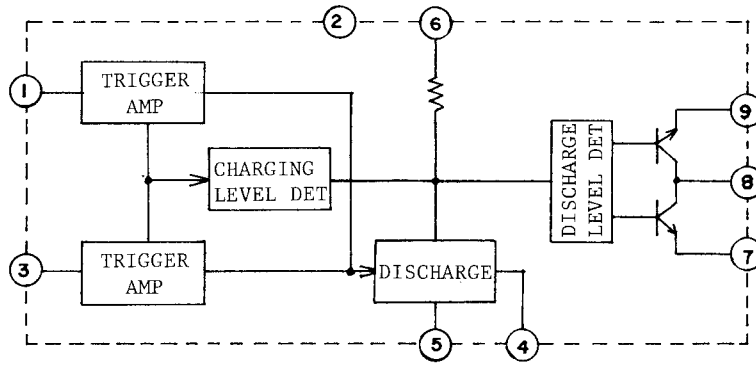

TA75902P

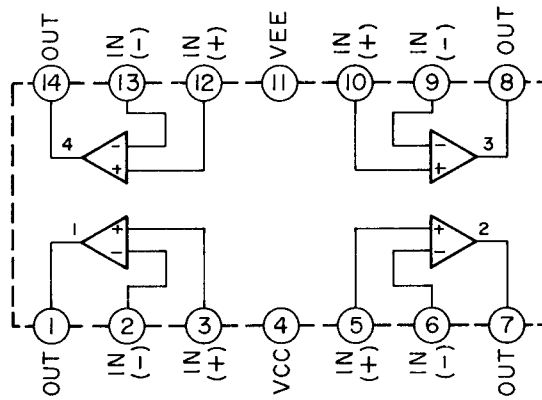

TC4011BP

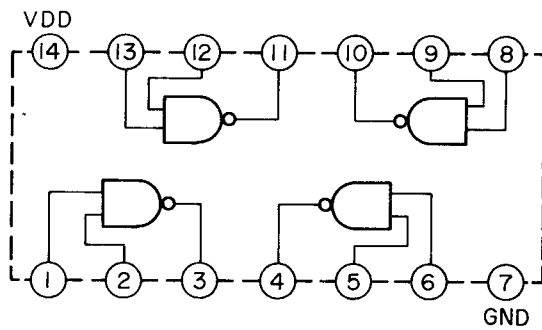

TC4012BP

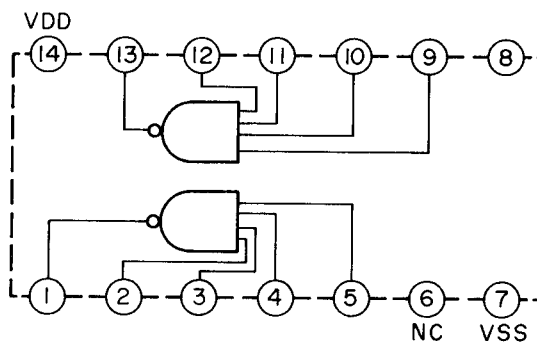

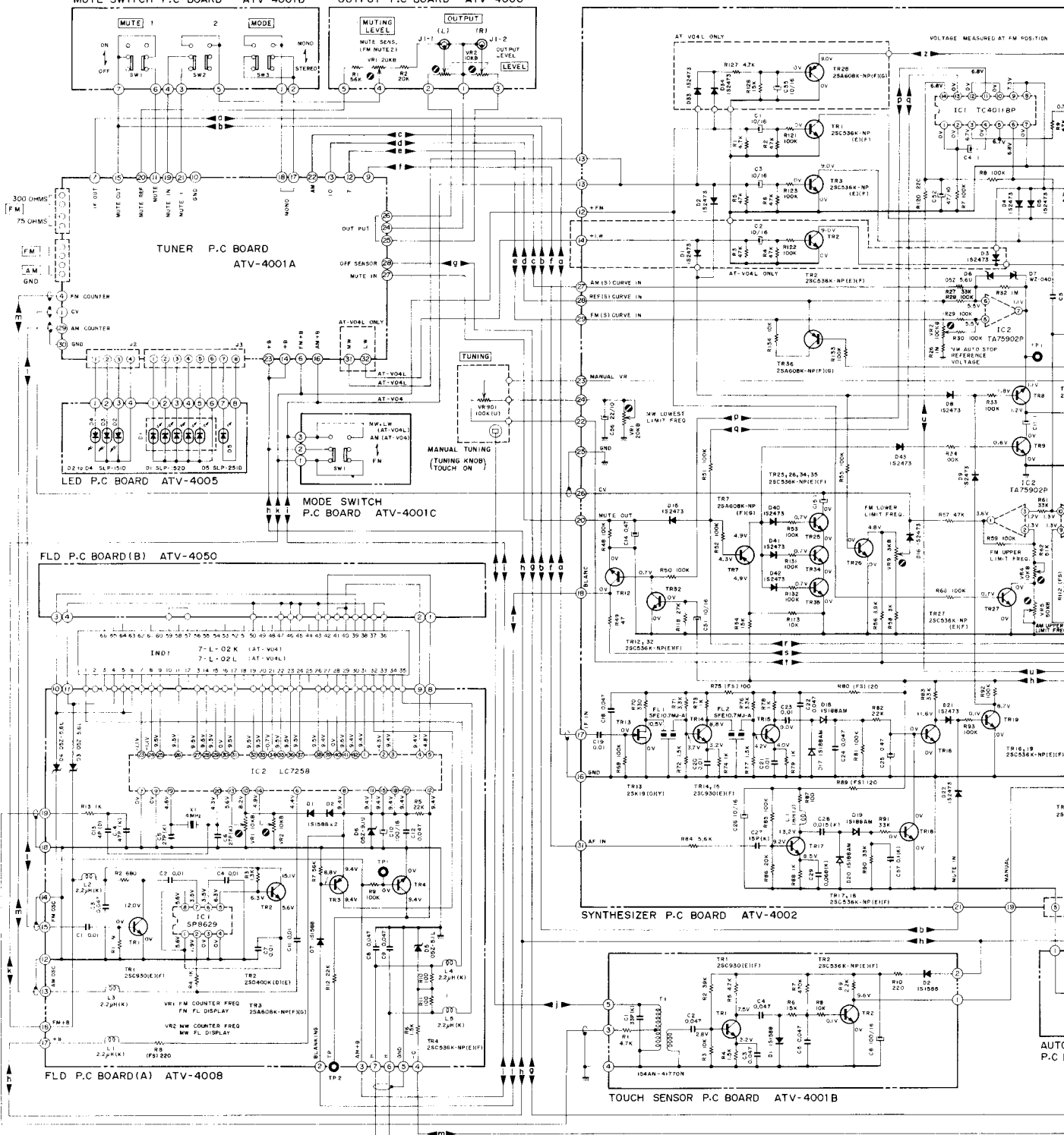

- 25A608K
- 25C336K
- 25C930
- 25D313
- 25K19

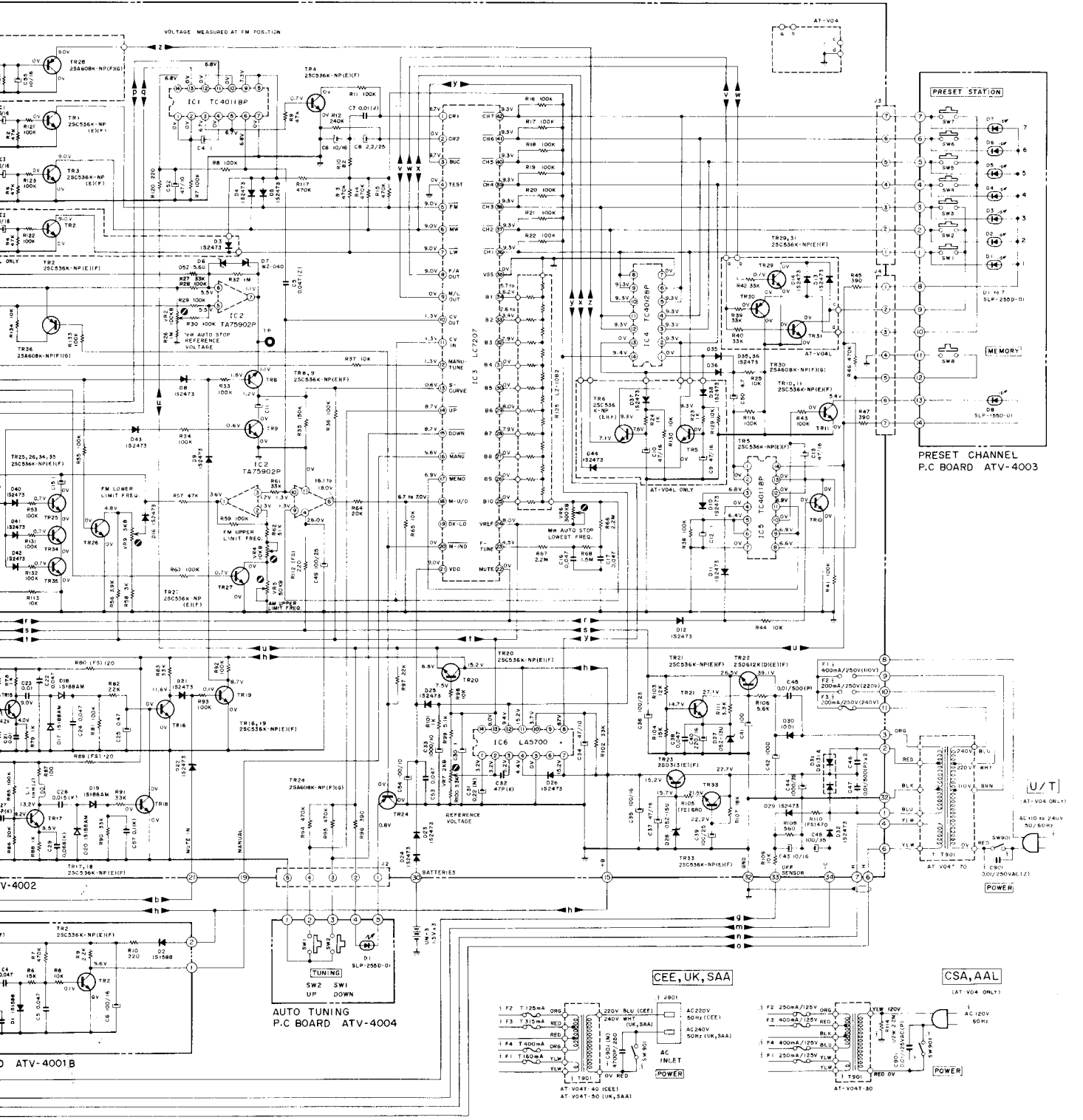

WARNING: INDICATES SAFETY CRITICAL COMPONENTS. FOR CONTINUED SAFETY, REPLACE SAFETY CRITICAL COMPONENTS ONLY WITH MANUFACTURER'S RECOMMENDED PARTS.  
 AVERTISSEMENT: IL INDIQUE LES COMPOSANTS CRITIQUES DE SÛRETÉ. POUR MAINTENIR LE DEGRÉ DE SÛRETÉ DE L'APPAREIL, NE REMPLACER LES COMPOSANTS DON'T LE FONCTIONNEMENT EST CRITIQUE POUR LA SÛRETÉ QUE PAR DES PIÈCES RECOMMANDÉES PAR LE FABRICANT.

NOTE: UNLESS OTHERWISE SPECIFIED ALL RESISTORS IN OHMS (1/4W/1/2W) ALL CAPACITORS IN UF 50WV(U) (FS) = FAIL SAFE RESISTORS (R) = NON-POLAR CAPACITORS POWER TRANSFORMER IS DIFFERENT ACCORDING TO AREA

AT-V04/L  
 SCHEMATIC DIAGRAM  
 No.2-1 1601218A

AT-VO4/L

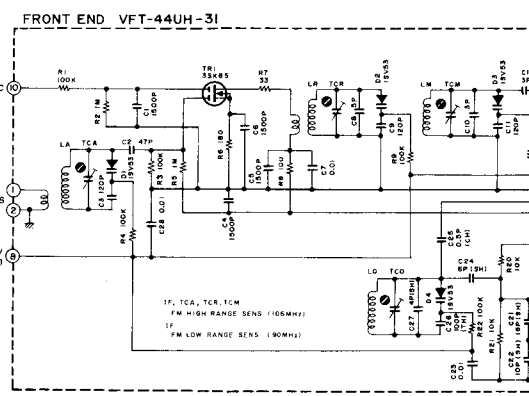
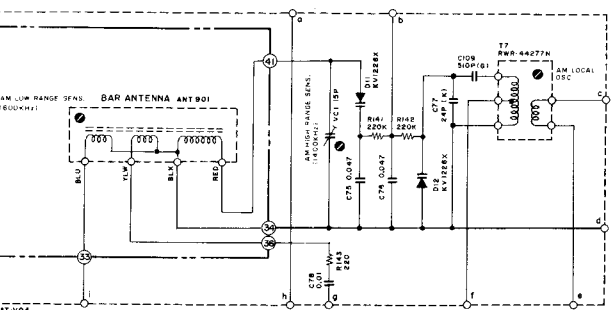
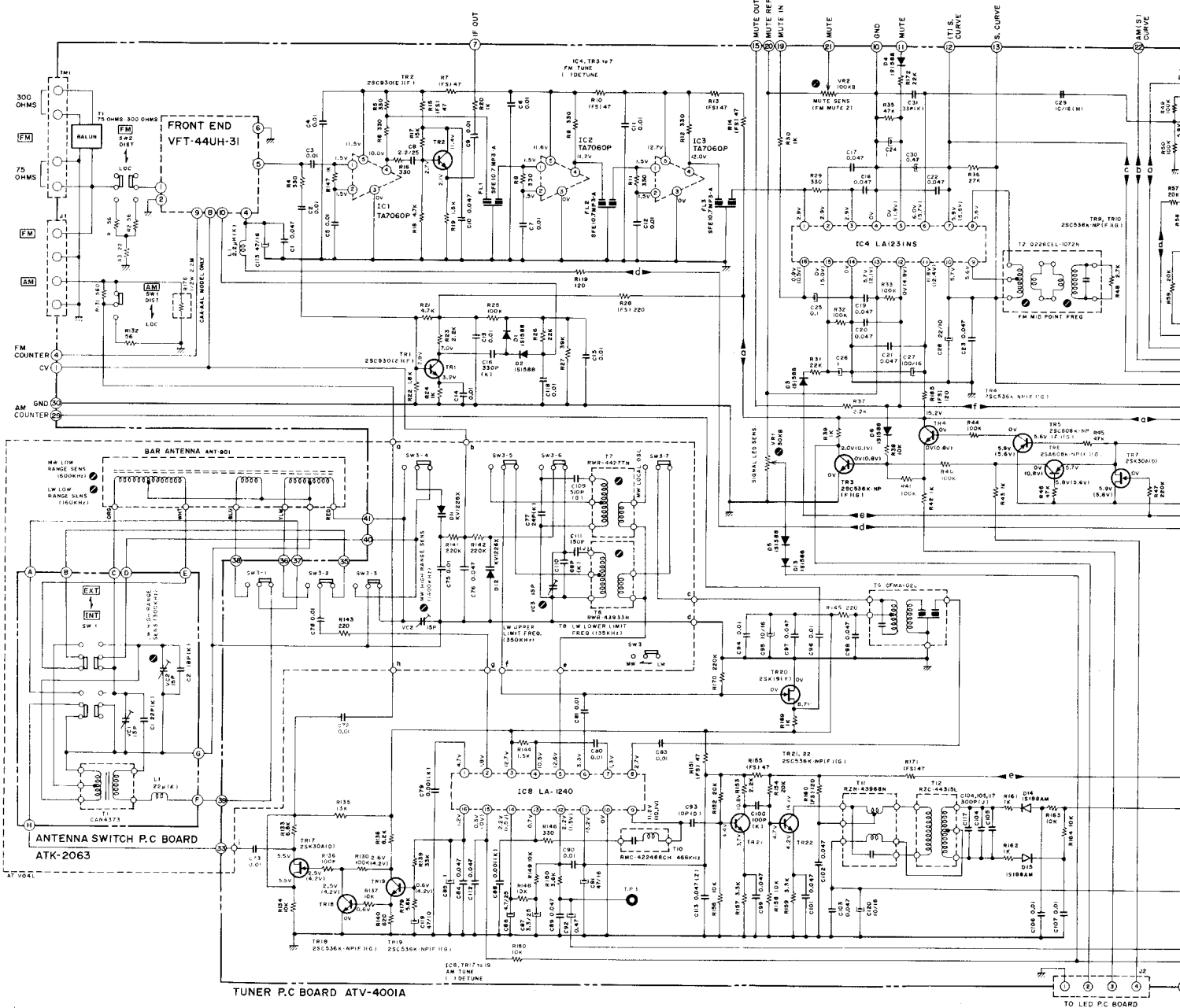

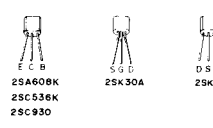
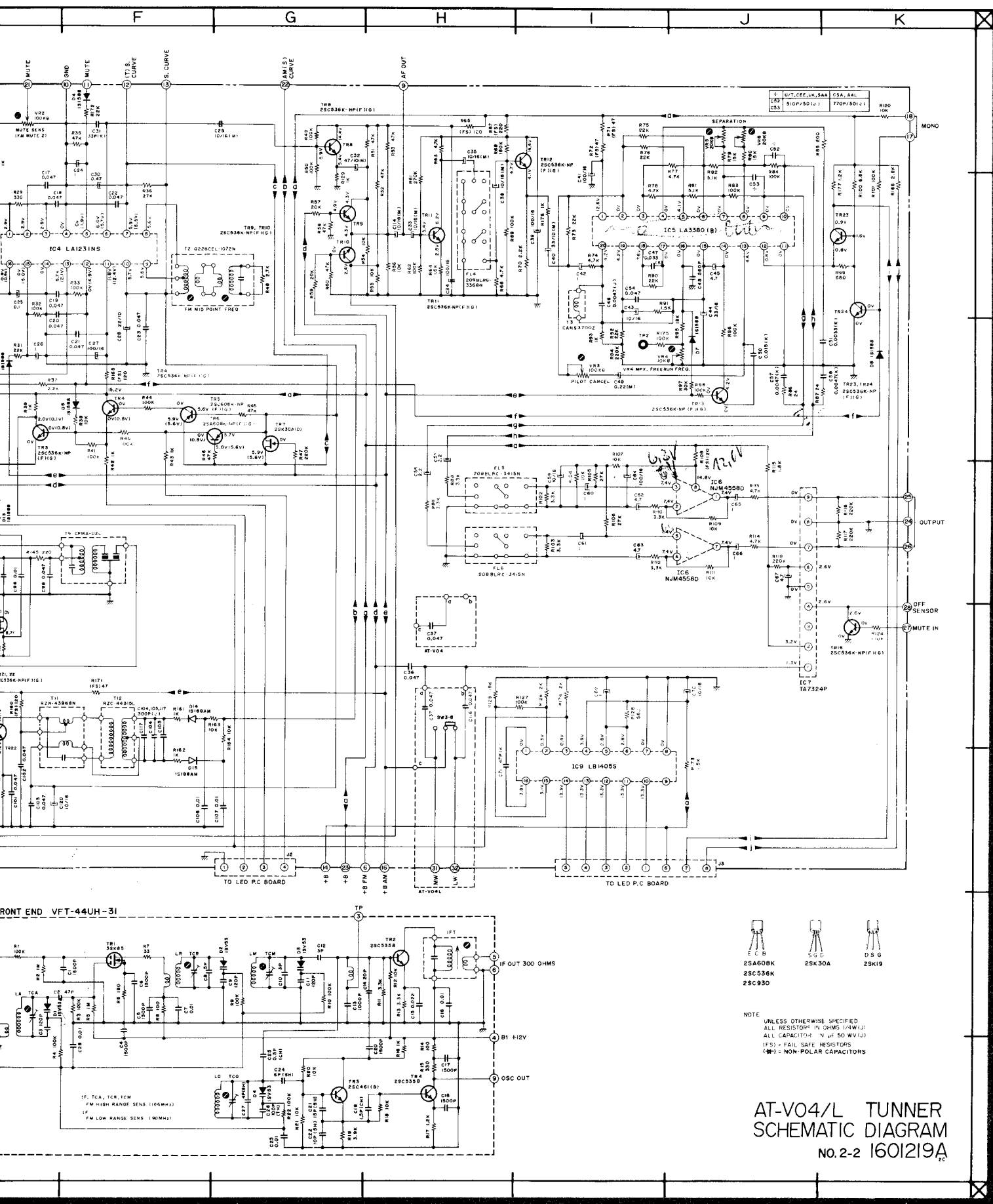

NOTE  
 UNLESS OTHERWISE SPECIFIED  
 ALL RESISTORS IN OHMS (1/4W/1%)  
 ALL CAPACITORS IN P.F. (50 MV/1%)  
 (FS) = FAIL SAFE RESISTORS  
 (NP) = NON-POLAR CAPACITORS

**AT-V04/L TUNER**  
**SCHEMATIC DIAGRAM**  
 No. 2-2 1601219A



TUNER P.C BOARD ATK-2001A

U1, CEE
U2, SAA
C1 330P(U)
C2 330P(U)

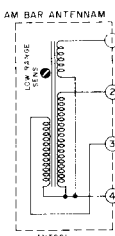
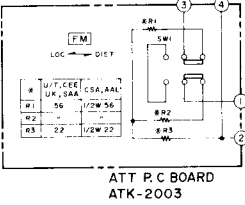
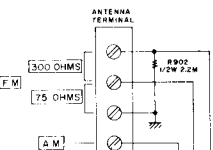
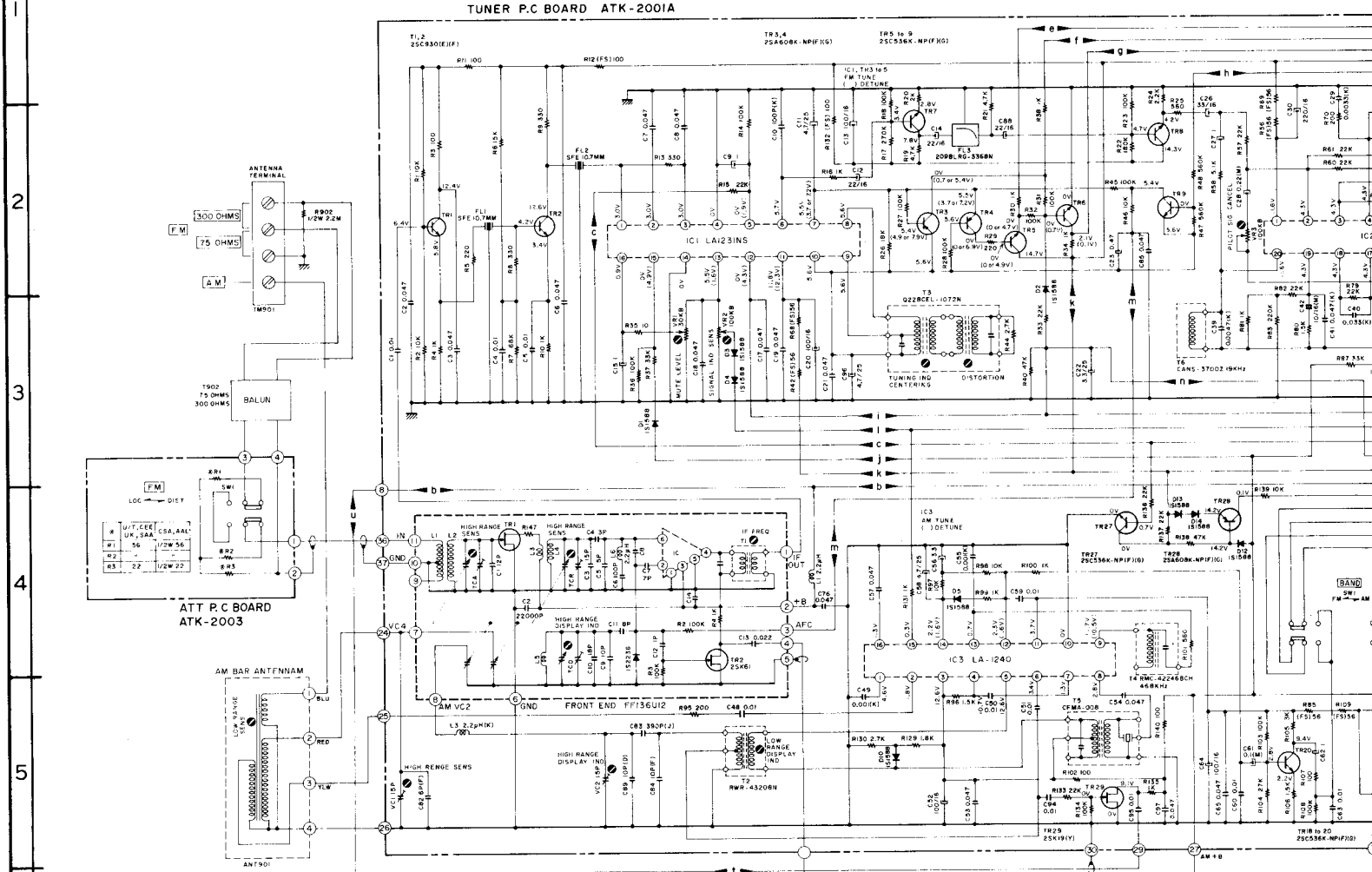

FLD P.C BOARD(B) ATV-4050

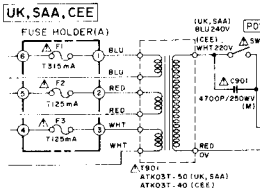
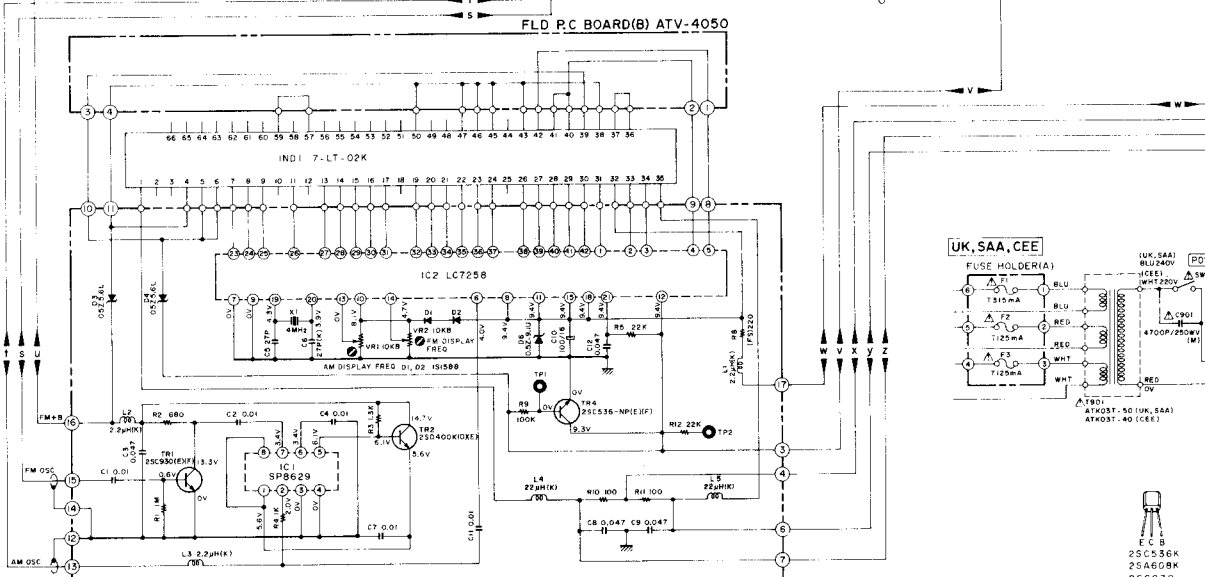

FLD P.C BOARD(A) ATV-4008

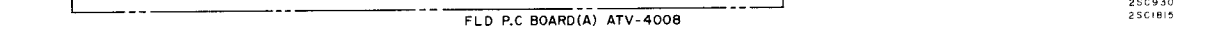

F G H I J K

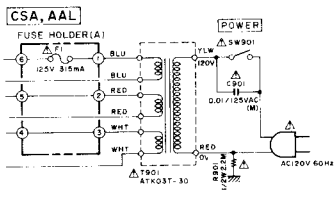
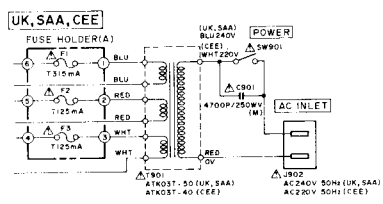
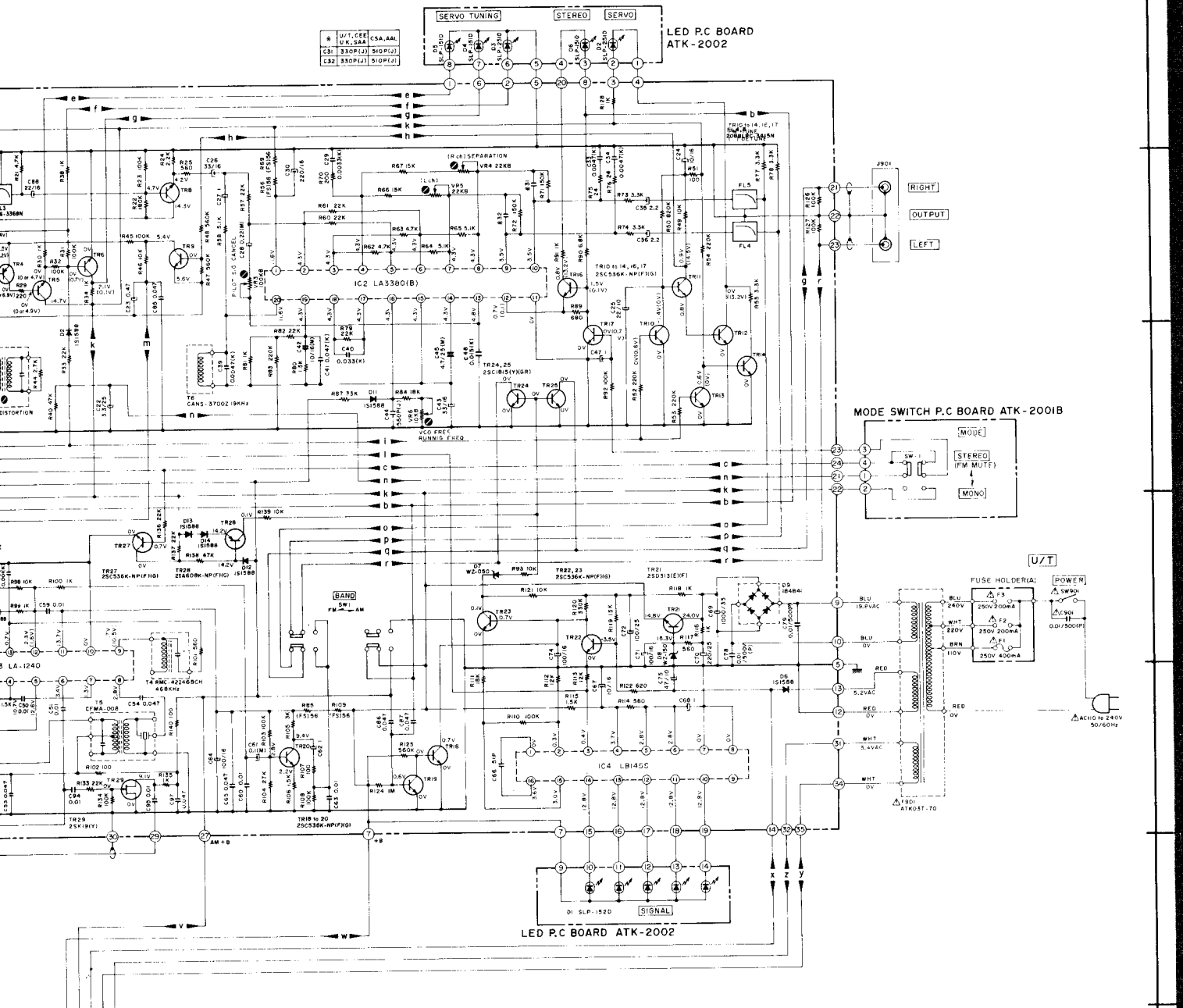

WARNING: AND RATED SAFETY CRITICAL COMPONENTS ONLY. EXTENDED WARRANTY. REPLACE SAFETY CRITICAL COMPONENTS ONLY WITH MANUFACTURER'S RECOMMENDED PARTS.  
 AVOID REVERSE POLARITY. UNUSABLE COMPONENTS CRITICAL TO YOUR MAINTENANCE. PLEASE BE SURE TO CHECK THE POLARITY OF ALL CAPACITORS. CONTACT THE FACTORY FOR MORE INFORMATION. PLEASE REFER TO THE SERVICE MANUAL FOR THE AT-K03.

NOTE  
 UNLESS OTHERWISE SPECIFIED  
 RESISTORS IN OHMS (1/4W/1%)  
 CAPACITORS IN pF 50WV(2)  
 (FS) = FAIL SAFE RESISTOR  
 (-) = NON-POLAR CAPACITORS  
 POWER TRANSFORMER IS DIFFERENT  
 ACCORDING TO AREA

- 25C536K
- 25A6GBK
- 25C930
- 25C1615
- 25D400
- 25D400
- 25K19

AT-K03  
 SCHEMATIC DIAGRAM  
 No. 1601226A