

AP-001C

SERVICE MANUAL

PARTS LIST

MODEL AP-001C

The AKAI logo consists of the word "AKAI" in a bold, white, sans-serif font. The letters are set against a solid black rectangular background. The letters are slightly shadowed, giving them a three-dimensional appearance as if they are floating above or attached to the black background.

ALSO APPLICABLE TO MODEL AP-001



TURNTABLE

MODEL AP-001C

ALSO APPLICABLE TO MODEL AP-001

SECTION 1	SERVICE MANUAL	1
SECTION 2	PARTS LIST	21

SECTION 1

SERVICE MANUAL

TABLE OF CONTENTS

I. TECHNICAL DATA	2
II. DISMANTLING OF UNIT	3
III. ARRANGEMENT OF PRINCIPAL PARTS	4
IV. AUTO STOP POSITION ADJUSTMENT	5
V. CYCLE CHANGE (MOTOR PULLEY REPLACEMENT)	6
VI. PLAYER CARE	7
1. LIFE OF STYLUS	7
2. STYLUS CHANGE	7
3. LUBRICATION	7
VII. BLOCK DIAGRAM	8
VIII. TROUBLE SHOOTING CHART	14

I. TECHNICAL DATA

1. TURNTABLE SECTION

TURNTABLE	300 mm aluminium alloy die cast
DRIVE SYSTEM	Belt drive
MOTOR	4-pole synchronous motor
SPEED	33-1/3 and 45 rpm
WOW & FLUTTER	0.06% WRMS
SIGNAL TO NOISE RATIO	Better than 50 dB

2. TONE ARM SECTION

TONE ARM	Static-balanced type stainless steel tubular arm with inside force canceler and lateral balance weight
ARM LENGTH	220 mm
STYLUS PRESSURE ADJUSTMENT RANGE	0 to 4 grams
APPLICABLE CARTRIDGE WEIGHT	4 to 10 grams (10 to 15 grams using sub-weight)
ARM LIFTER	Oil damped
OVERHANG	15 mm
SHELL WEIGHT	8.0 grams

3. CARTRIDGE SECTION

CARTRIDGE	VM (dual magnet type) Audio Technica Model AT-11 with 0.7 mil spherical diamond stylus. Model AP-001C only. (Model AP-001 does not include cartridge)
FREQUENCY RESPONSE	15 Hz to 25,000 Hz
OUTPUT VOLTAGE	4 mV (1,000 Hz 50 mm/sec)
CHANNEL SEPARATION	20 dB (1,000 Hz)
OPTIMUM STYLUS PRESSURE	2.5 grams
REQUIRED LOAD IMPEDANCE	47k to 100 k ohms
WEIGHT	5.5 grams

4. GENERAL SPECIFICATIONS

POWER REQUIREMENT	CSA Models 120V, 60 Hz CEE Models 220V, 50 Hz Other Models 110V/220V, 50/60 Hz and 240V, 50 Hz
DIMENSIONS	440(W) x 140(H) x 350(D) mm (17.3" x 5.5" x 13.8")
WEIGHT	6.3 kg (13.9 lbs.)

NOTE: For improvement purposes, specifications and design are subject to change without notice.

II. DISMANTLING OF UNIT

In case of trouble, etc. necessitating disassembly, please disassemble in the order shown in photographs. Reassemble in reverse order.

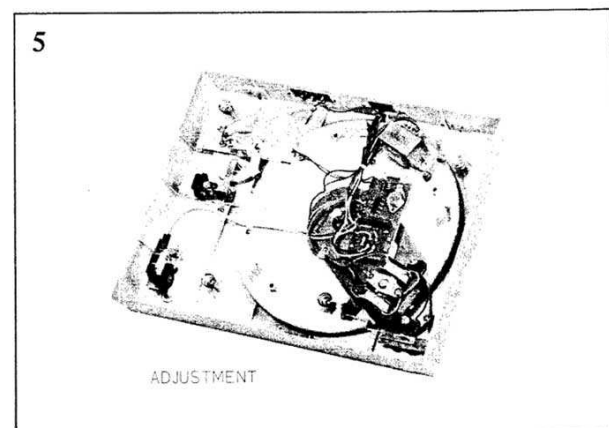
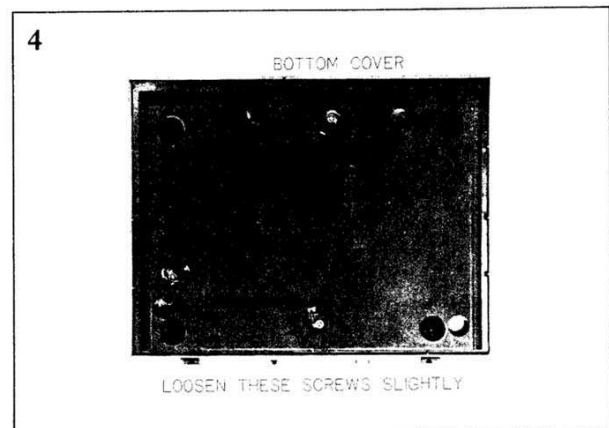
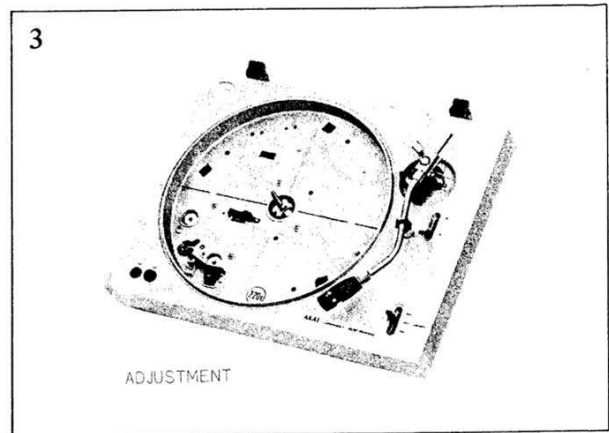
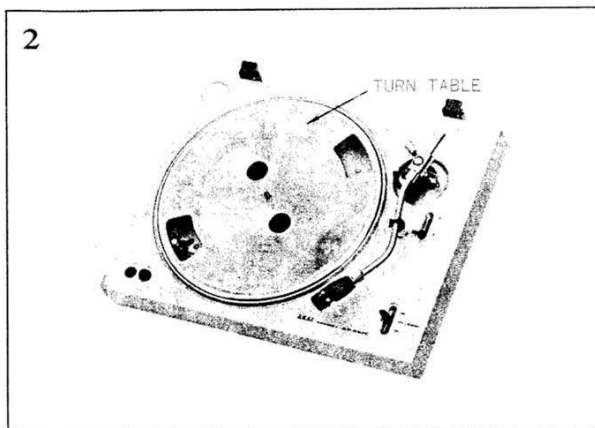

III. ARRANGEMENT OF PRINCIPAL PARTS

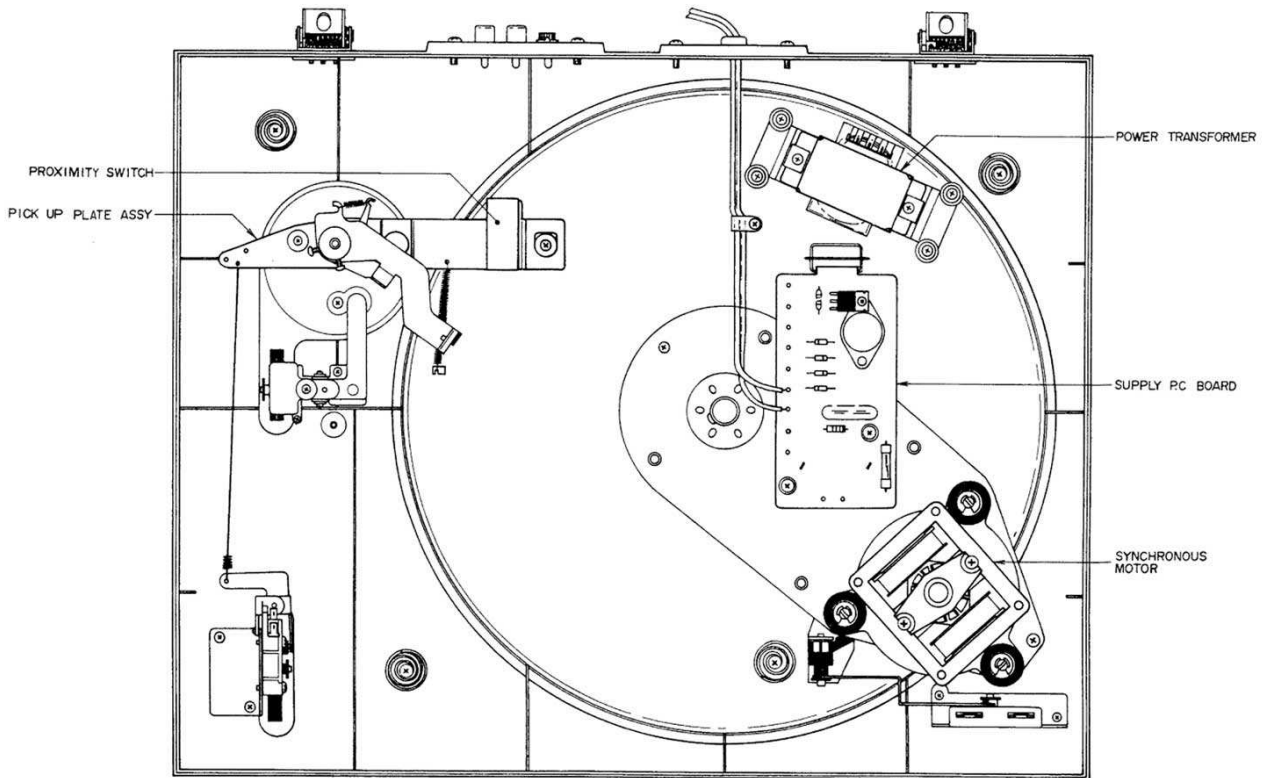
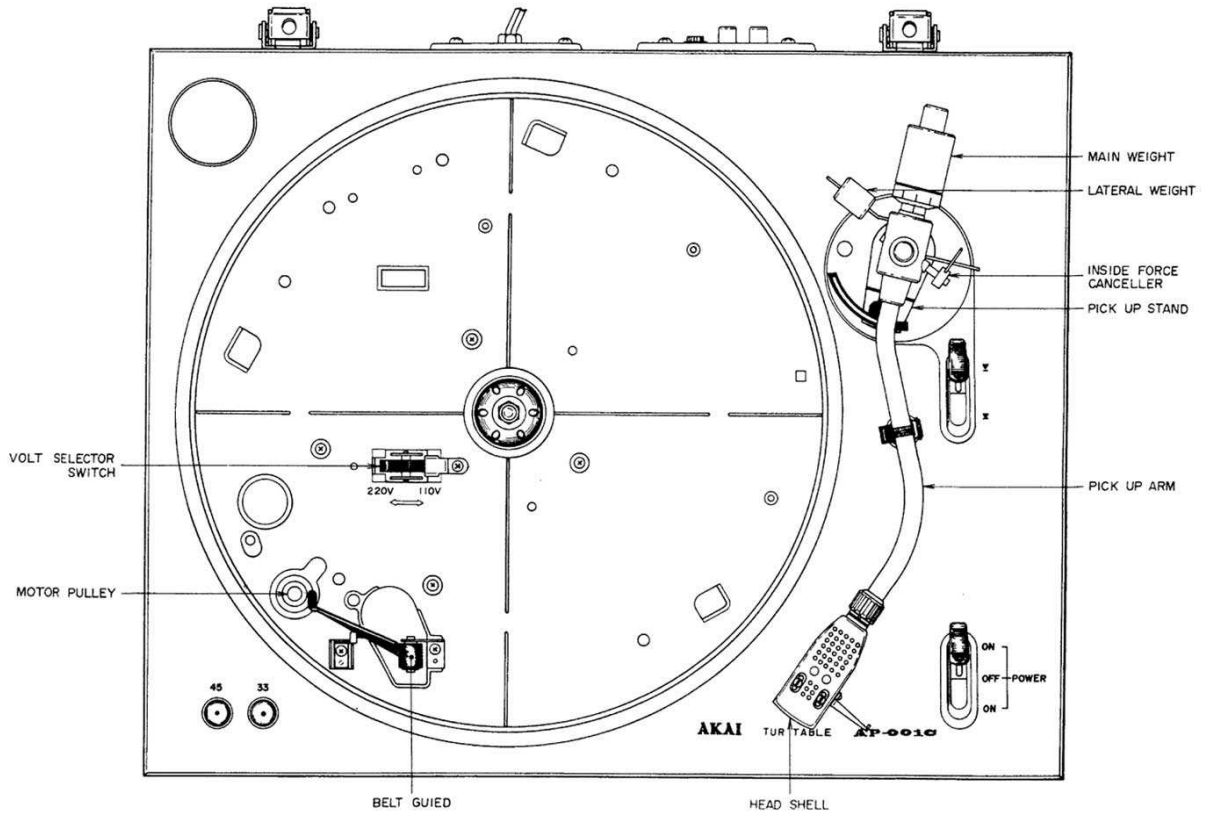

IV. AUTO STOP POSITION ADJUSTMENT

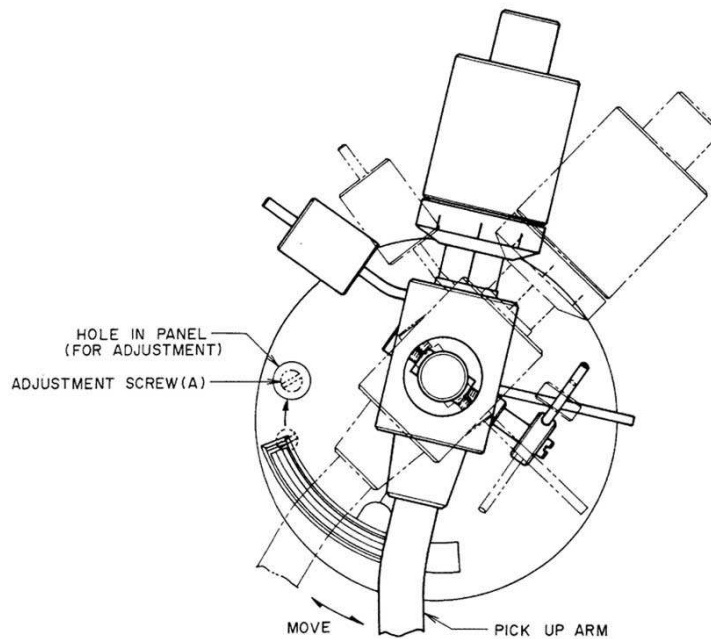

Fig. 1

Remove the rubber plug on panel toward the rear part of the pick up arm. When the pick up arm is moved as shown in Fig. 1, Adjustment Screw (A) becomes accessible through the hole from which the rubber plug has been removed. When Adjustment Screw (A) is turned clockwise, stop position will be advanced and when turned counter-clockwise, stop position will be delayed.

Use a 30 cm record as standard and adjust stop position as follows with Adjustment Screw (A).

For adjusting toward outer circumference turn clockwise.

For adjusting toward inner circumference turn counter-clockwise.

If only proper inner or outer adjustment can be attained, this means that adjustment at some other place is necessary. After source of trouble has been located and corrected, re-adjust adjustment screw (A).

- NOTE: 1. Because of one adjustment screw only, stop position of 30 cm 17 cm record will be the same.
2. After adjustment, be sure to re-install rubber plug.

V. CYCLE CHANGE (MOTOR PULLEY REPLACEMENT)

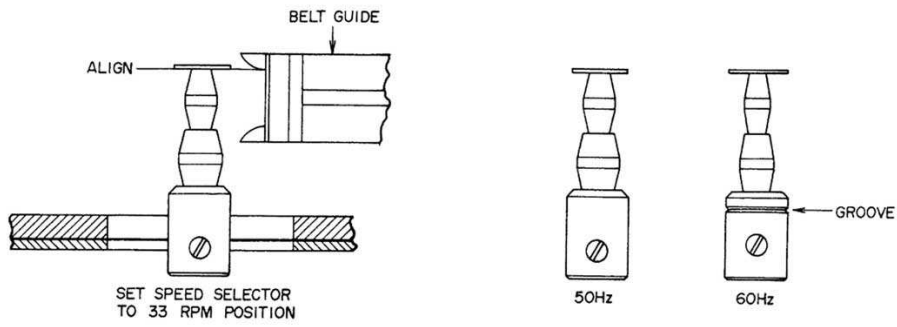

Fig. 2

50 Hz and 60 Hz cycle change is effected by changing the motor pulley.

50 Hz and 60 Hz differentiation can be determined by the groove on the 60 Hz pulley. While viewing horizontally as shown in Fig. 2, install so that the lower part of the motor pulley brim and the lower part of the belt guide are lined up. Set speed selector to 33 rpm position, install the belt and switch on power. If a rumbling noise from the belt can be heard and speed changing is not smooth, adjust installation position of motor pulley.

VI. PLAYER CARE

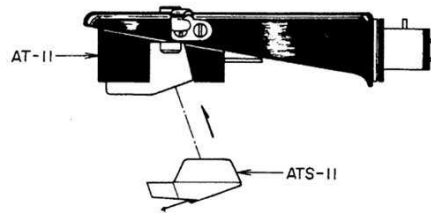

Fig. 3

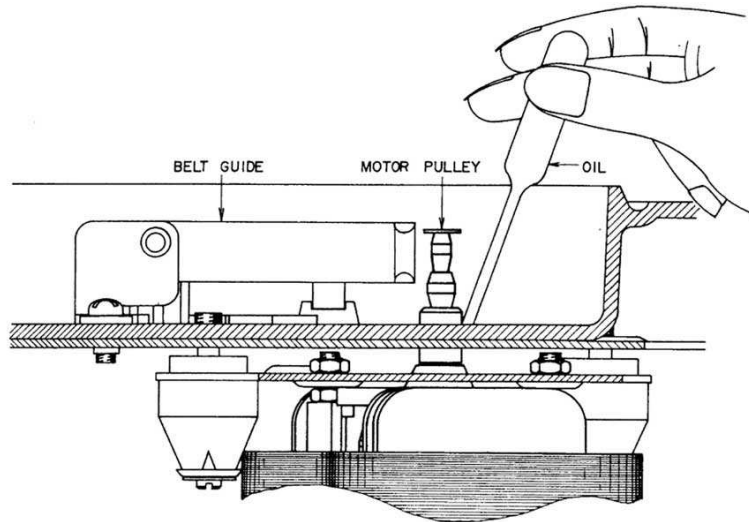

Fig. 4

1. LIFE OF STYLUS

The lifetime of stylus is about 500 hrs. of use (both sides of about 500 30 cm LP records). If the stylus becomes old, because the record will be damaged and tone quality will become inferior, be sure to replace as soon as is needed. If records on which dust is allowed to accumulate are played, the stylus will wear especially fast and the record surface will be scratched. Therefore, please be sure to keep record clean by wiping and cleaning the record grooves with water soaked gauze. Also if dust adheres to the turntable mat, as this will cause the record to become dirty easily, the mat should also be kept clean.

2. STYLUS CHANGE

When replacing stylus, be sure that the stylus (ATS-11) is inserted properly in the direction of the arrow mark shown in Fig. 3 and fits into cartridge firmly. Use only model ATS-11 stylus which is for use in model AT-11 cartridge.

3. LUBRICATION

Because for rotating parts and parts which rub together during operation, oilless metal and the best grease or oil is used, your machine will not need lubrication for some time. About once per year use standard accessory player oil, and apply one or two drops to the motor shaft as shown in Fig. 4. In case you do not have player oil, use #60 spindle oil or a high grade machine oil. If used continually for business purposes, etc., oil about once or twice per month.

CAUTION: Following lubrication, because oil will adhere to the drive belt and pulley and to the turntable etc., wipe the oil off of these parts with a cloth to which a little carbon tetrachloride or thinner (benzene can be also be used) has been applied.

VII. BLOCK DIAGRAM

1. CARTRIDGE

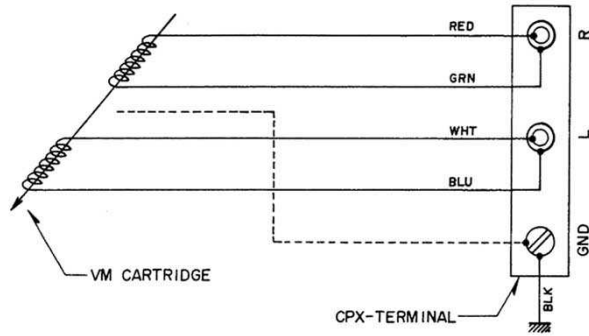

2. SWITCHABLE MODELS

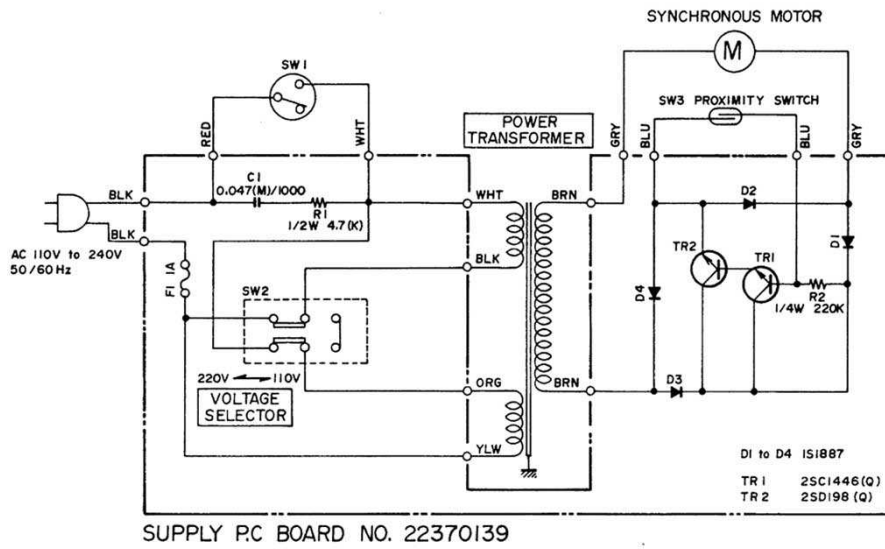

3. CSA MODELS

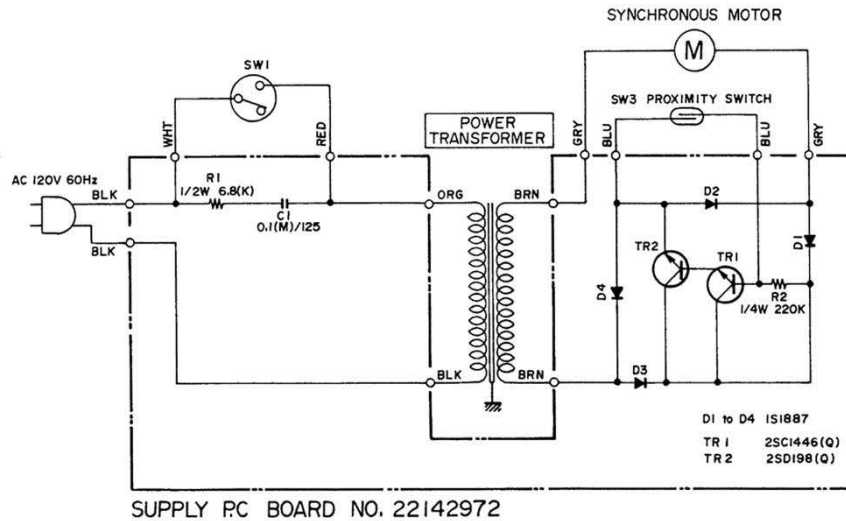

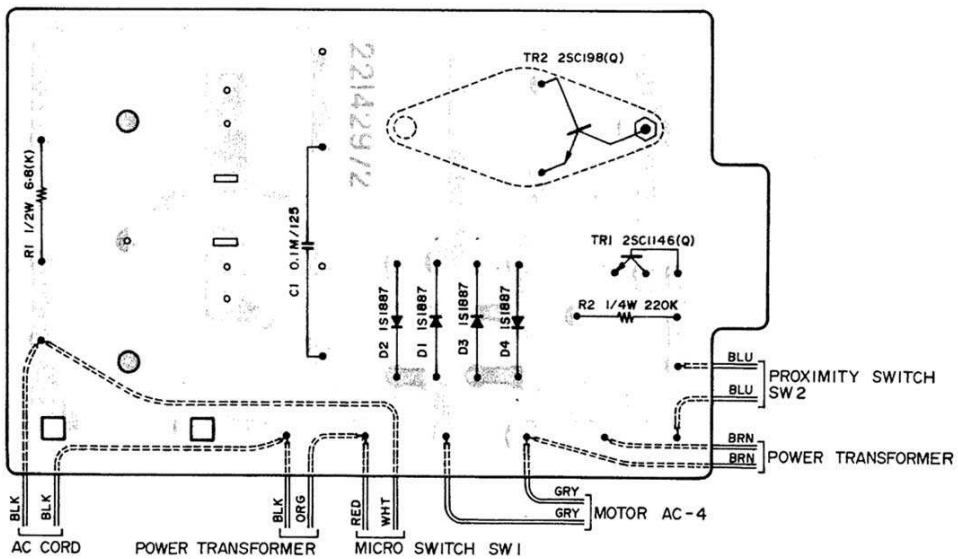
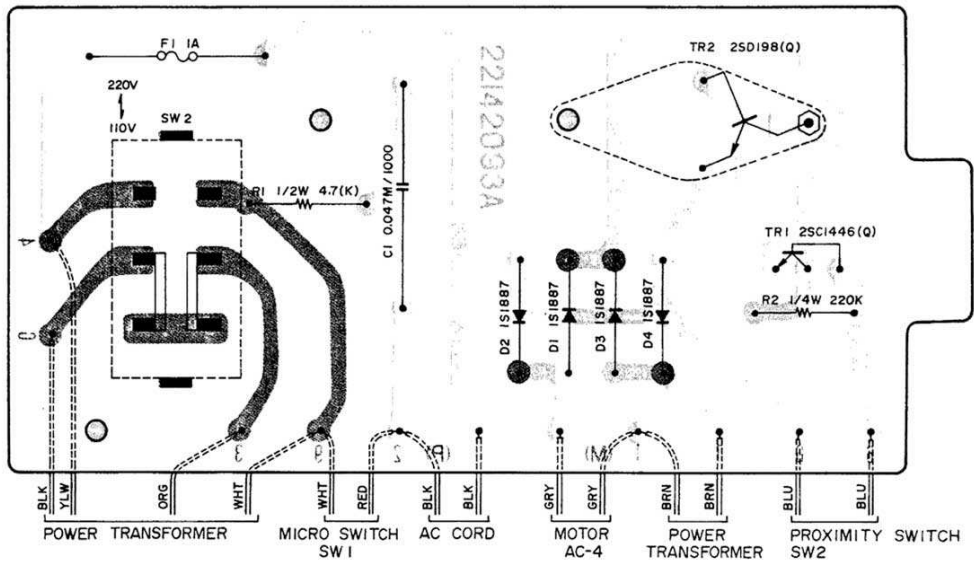

4. BSI MODELS

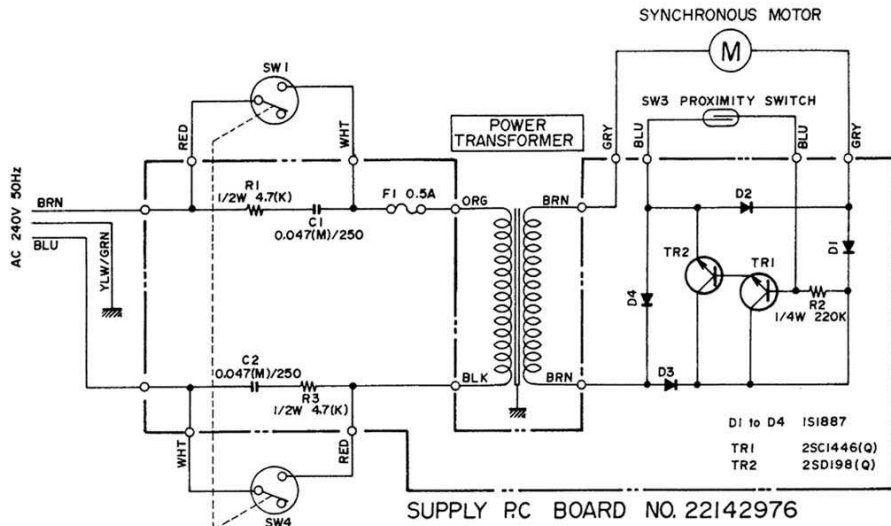

5. AST MODELS

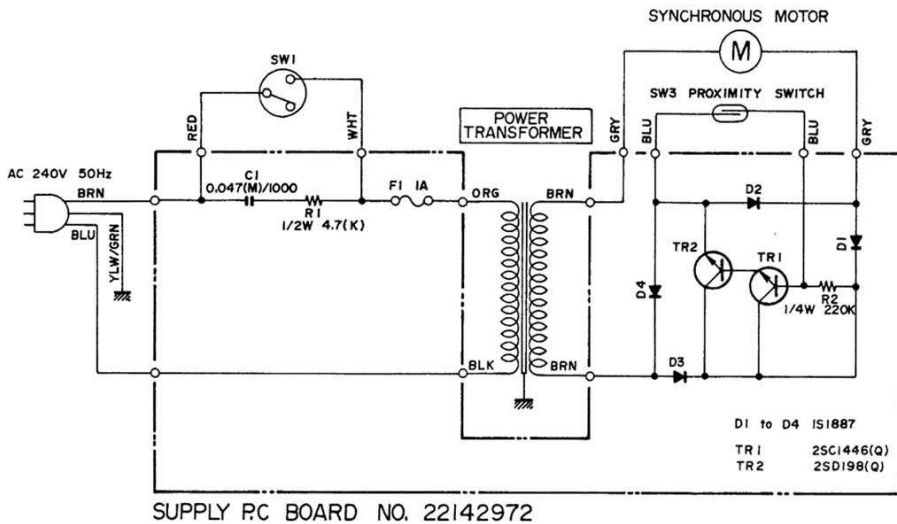

6. OTHER MODELS

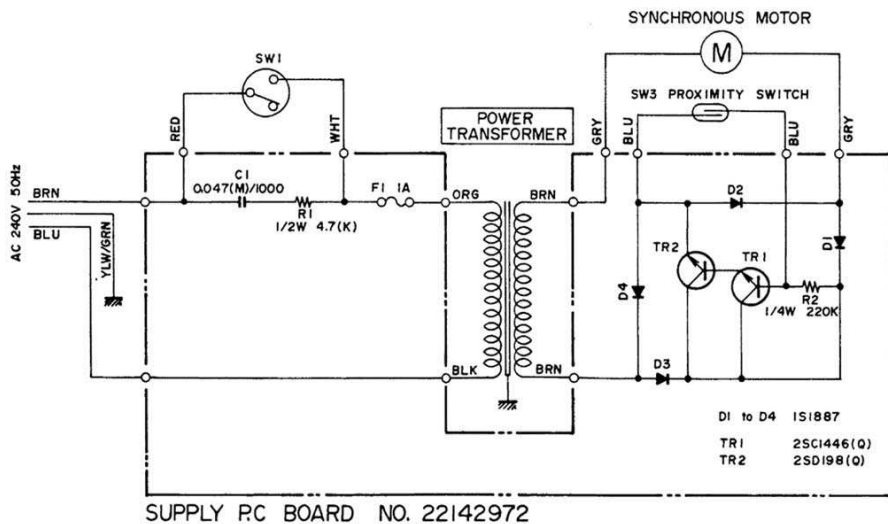

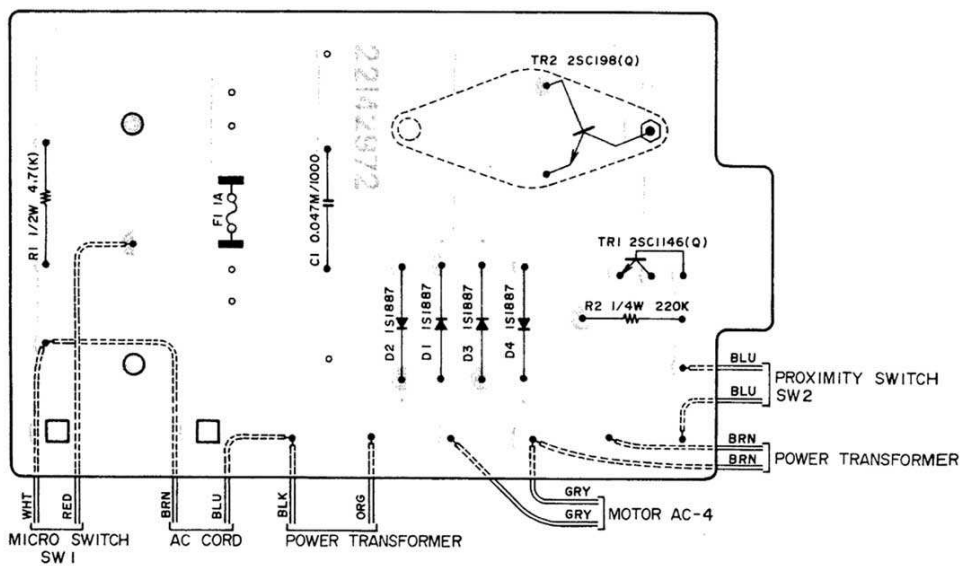
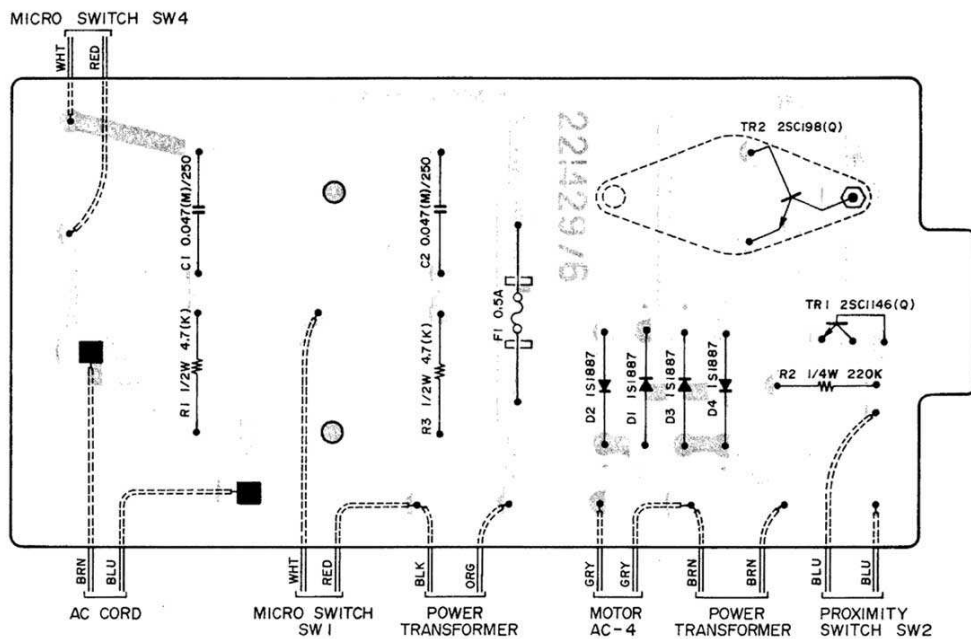

7. CEE MODELS

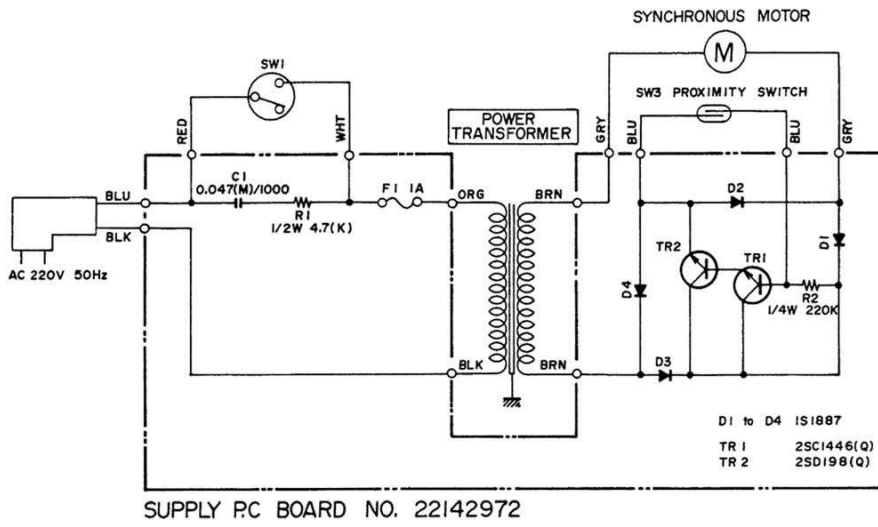

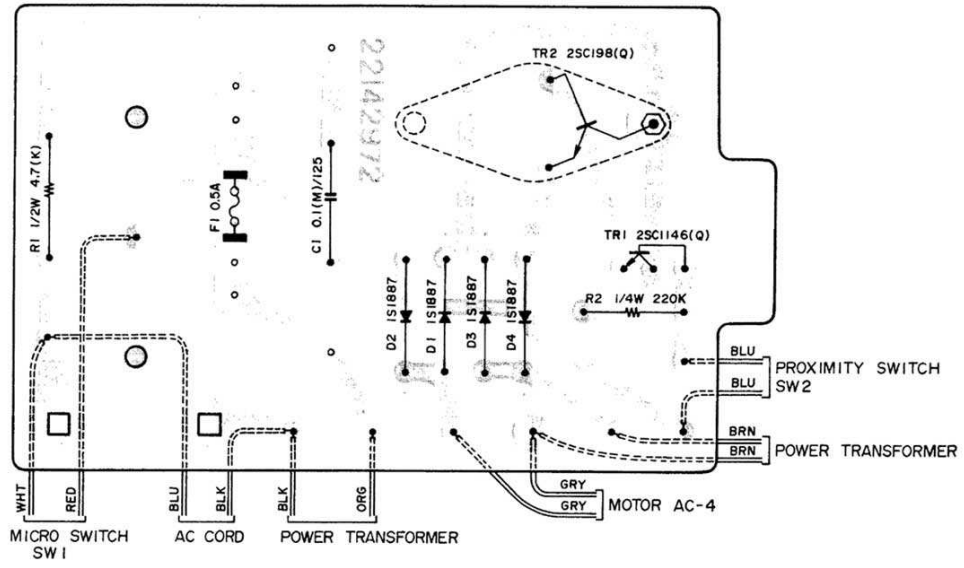

VIII. TROUBLE SHOOTING CHART

Condition	Explanation	Confirmation	Source	Countermeasure
Poor tone quality	1. Distortion (When using new record)	1. Distortion persists after changing stylus and confirming normal pick-up arm operation. (Amp. Speaker normal)	Faulty cartridge.	Replace cartridge
		2. Crackling sound even when playing new record. Especially vague at high range.	Worn stylus.	Replace stylus.
		3. A crunching sound exists and there is a sudden change in sound level. Also the level of right and left differs greatly.	Bent stylus.	
		4. Sound is vague or distortion exists.	Dust adhering to stylus.	Clean stylus.
		5. Stylus jumps.	Insufficient pressure.	Readjust stylus pressure.
		6. Stylus sinks to far into cartridge body during record playback.	Too much pressure.	
	2. Hum noise.	1. When pick up arm or player body is touched with your hand, hum noise increases.	Faulty grounding between cartridge and amp. input or turntable and amp.	Replace or repair ground wire.
		2. A hum is emitted from one channel (or both channels).	Faulty pin plug Connection.	Connect perfectly
		3. Hum is altered by changing position of lead wire from pick-up.	Lead wire from pick-up and source wiring is too close together.	Move lead wire to obtain minimum hum.
	3. Left/right sound separation poor.	Using a monaural record, left/right sound scatters and is not emitted from the center.	The plus and minus terminals are reversed on one side at cartridge out-put pin and shell pin connection or faulty cartridge.	Connect plus and minus correctly. Replace cartridge.
	4. Distortion at one channel only.	1. Observe pick-up arm head during record performance.	Bent pick-up head.	Replace pick-up arm.
		2. After pick-up arm side pressure and zero balance adjustment, pick-up arm does not move smoothly by means of inside force canceller.	Pick-up arm rotating shaft faulty.	Replace pick-up arm assy.
		3. Pick-up arm heavy or catches when moved to left and right by hand.	Installation of pick-up plate assy faulty.	Correct pick-up plate installation height as specified.
5. No sound	1. Check pin plug cord lead-through with tester.	Disconnected or broken wire.	Replace pin plug cord.	
	2. Check cartridge terminal DC resistance with tester. (L ch, R ch)	Broken or shorted wire inside cartridge.	Replace cartridge.	
Unusual noise	1. Mechanical noise (direct noise)	1. Belt contacting belt guide.	Faulty motor pulley height.	Adjust height of motor pulley.
		2. Observe motor pulley during revolutions.	Variation in motor pulley.	Replace motor pulley.
		3. During revolutions, vibration exists or noise is audible.	Faulty motor.	Replace motor.
		4. During motor rotation, if arm or table mount is touched with your hand, vibration is evident.	Faulty installation of motor or variation in motor cushions.	Adjust motor installation position. Replace motor cushion.

Condition	Explanation	Confirmation	Source	Countermeasure
	2. Electrical noise. (from speaker)	1. Sometimes shock noise and hum is emitted. Interference when lead wire is moved or no sound periodically.	Lead wire leak or lead wire is broken or disconnected. Faulty pin plug cord connection.	Repair or replace lead wire. Make proper pin plug cord connection.
		2. Interference when upper part of shell is lightly tapped.	Defective cartridge. Faulty cartridge terminal connection.	Replace cartridge. Make proper lead wire connection.
		3. Vibration and noise from motor during revolutions.	Faulty motor.	Replace motor.
Turntable does not rotate. (or rotation is unstable)	1. Electrical circuit problem.	1. Check Supply P.C Board fuse with tester.	Fuse blown.	Replace with proper fuse.
		2. Check Proximity switch lead-through with tester.	Shorted.	Replace Proximity switch.
		3. Check power switch lead-through with tester.	Open.	Replace micro switch.
		4. Check main lead wires with tester.	Disconnected or broken lead wire.	Replace or repair lead wire.
		5. Check motor coils with tester.	Disconnected or broken wire.	Replace motor.
		6. When rotor is rotated by hand, it catches or rotation is not light and smooth.	Insufficient oil.	Lubricate rotor shaft and clean.
	2. Table shaft out of order.	When turntable is rotated by hand it seems heavy. Unusual noise and too much rattle (with belt removed).	Insufficient oil.	Lubricate table shaft and bearing. Replace table shaft.
	3. Speed change mechanism defective.	1. Slippage between belt, motor pulley and turntable.	Worn out belt. Oil adhering to belt.	Replace belt. Clean with carbon tetrachloride or alcohol.
		2. Belt does not run on middle of motor pulley (drum-like part).	Faulty motor pulley height.	Adjust motor pulley height and motor slant.
		3. Belt rubbing noise.		
	4. Revolutions too slow. (or uneven)	Check for variation in shape of belt and whether dust is adhering to belt, motor pulley and turntable.	Variation of belt. Dust.	Replace belt. Clean with carbon tetrachloride or alcohol
Operation of manual lifter faulty. (at record performance)	1. Lifting or lowering takes place too fast when manipulating the lifter manually.	1. Observe plate spring.	Variation in shape or bent.	Repair or replace.
		2. Check lifter shaft silicon oil.	Insufficient silicon oil.	Apply silicon oil (200000CS).
	2. Lifting or lowering is too slow when manipulating the lifter manually.	1. Check strength of pressure coil spring.	Pressure coil spring has lost strength.	Replace pressure coil spring.
		2. Check lifter silicon oil.	Too much oil.	Wipe off oil.
Position of arm auto stop faulty.	1. Too soon.	Auto stop takes place too soon (17 cm, 30 cm record).	Faulty adjustment.	Use a 30 cm record as standard and adjust by turning adjustment screw (A) counter-clockwise.
	2. Too late.	Auto stop takes place too late (17 cm, 30 cm record).	Faulty adjustment	Use a 30 cm record as standard and adjust by turning adjustment screw (A) clockwise.

Condition	Explanation	Confirmation	Source	Countermeasure
	3. Auto stop of either 17 cm or 30 cm record sooner or later than normal auto stop.	When the bottom panel is removed and the movement of the aluminum plate (switch holder plate) on which the Proximity Switch is installed is changed by manipulating the change lever, the stopper screw sticks to part of the square hole in the aluminum plate and does not move freely.	Faulty connection pole or adjustment.	Replace connection pole and also change holes (choose the most suitable of the 3 holes) at tip of aluminum plate to which connection pole is connected.
	4. Specified stop position.	30 cm, 25 record operation begins between 115φ and 109φ (center 56R). 17 cm record operation begins between 106φ and 98φ (center 51R).		

MEMO

MEMO

MEMO

MEMO

SECTION 2

PARTS LIST

TABLE OF CONTENTS

1. ASSEMBLY BLOCK (1)	23
2. ASSEMBLY BLOCK (2)	24
3. CABINET BLOCK	27
INDEX	28

HOW TO USE THIS PARTS LIST

1. This parts list is compiled by various individual blocks based on assembly process.
2. When ordering parts, please describe parts number, serial number, and model number in detail.
3. How to read List

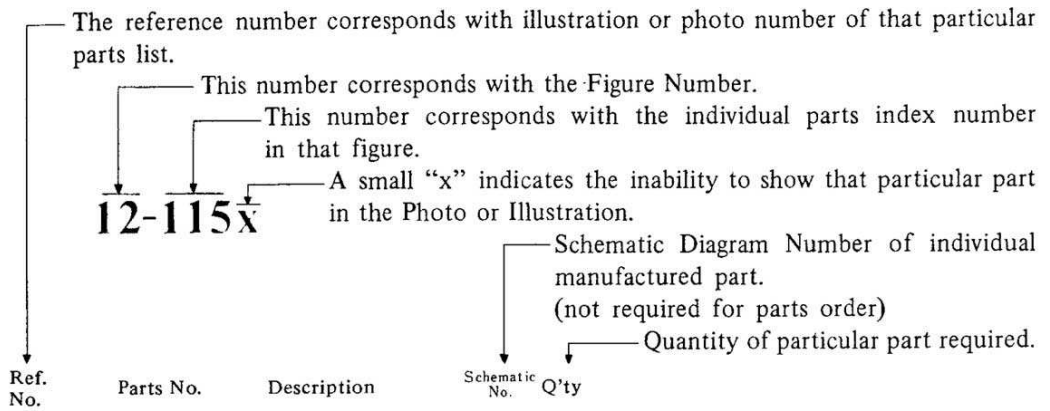

FLYWHEEL BLOCK #13

12-115x	800425	Flywheel Block Assy. Comp.	RDG #13	1
12-116	244506	Flywheel Only	RD-233	1
12-117x	244754	Felt, Flywheel	RD-275	1
12-118	251324	Main Metal Case	RD-236	1
12-119	253080	Main Metal	RD-237	1

4. The symbol numbers shown on the P.C. Board list can be matched with the Composite Views of Components of the Schematic Diagram or Service Manual.
5. Please utilize separate "Common List for Service Parts" for Resistor Parts orders.
6. The shape of the parts and parts name, etc. can be confirmed by comparing them with the parts shown on the Electrical Parts Table of P.C. Board.
7. Both the kind of part and installation position can be determined by the Parts Number. To determine where a parts number is listed, utilize Parts Index at end of Parts List.
It is necessary first of all to find the Parts Number. This can be accomplished by using the Reference Number listed at right of parts number in the Parts Index. (meaning of ref. no. outlined in Item 3 above).
8. Utilize separate "Price List for Parts" to determine unit price. The most simple method of finding parts Price is to utilize the reference number.

1) ASSEMBLY BLOCK (1)

Ref. No.	Parts No.	Description	Schematic No.	Q'ty
CABINET BLOCK				
1-1	TP710021	Rubber Cap	2088176800	1
1-2	TP720257	Rubber Cushion	2275683000	2
SPEED CHANGE BRACKET BLOCK				
1-3	BZ709323	Belt Guide Boock Comp. AP-001/C	2074690800	1
1-4	TP709334	Guard AP-001/C	2074051900	1
1-5	MB719008	Belt AP-003	2072861100	1
1-6	BM709356	AC Motor Block Comp. AP-001/C	2212547500	1
1-7	MB709391	Cushion Rubber AP-001/C	2088172200	3
1-8	MR709402	Motor Pulley 50 Hz AP-001/C	2071675000	1
1-9x	MR709413	Motor Pulley 60 Hz AP-001/C	2071675100	1
1-10	MS709424	Motor Hang Shaft (A) AP-001/C	2076463000	1
1-11	MS709435	Motor Hang Shaft (B) AP-001/C	2076463100	2
1-12	TP709446	Cushion Holder AP-001/C	2074672100	3
1-13	ZW712236	'E' Ring 4M		3
PU ARM BLOCK				
1-14	TP709457	PU Arm AP-001/C	2073174600	1
1-15	BL719381	Lifter Bar Block Comp. AP-003	2076165700	1
1-16	MS709468	Lifter Shaft AP-001/C	2076469000	1
1-17x	ZG709470	Cramp Coil Spring AP-001/C	2070381800	1
1-18x	ZW712361	'E' Ring 3M		1
1-19	BZ709481	PU Rest Block Comp. AP-001/C	2073871100	1
1-20	TP719594	Pick-up Stand AP-003	2073563700	1
1-21x	ZS712372	Screw, cone point Flat Socket 40x10		1
1-22x	ZS712653	Tapping Screw Pan head 30x10		3
TURN TABLE BLOCK				
1-23	TP709492	Turn Table AP-001/C	2072365300	1
1-24	TP709503	Table Sheet AP-001/C	2072368600	1
1-25	MV709514	Table Shaft Holder AP-001/C	2072568300	1
1-26	ZW719043	Special Nut AP-003	2079663100	1
1-27	ZW712697	Special Washer 101x170x10		1
1-28	ZS712765	Screw, pan head 30x4x4		1
1-29	MS709525	Table shaft AP-001/C	2076468900	1
LIFTER LEVER BLOCK				
1-30	BL709536	Lifter Lever Block Comp. AP-001/C	2075179400	1
1-31	SK715533	Knob	2283540100	2
RECORD SELECT CAM BLOCK				
1-32	BZ709547	Record Select Cam Block Comp. AP-001/C	2075772200	1
ELECTRICAL PARTS BLOCK				
1-33	ES718648	Micro SW. AP-003	2214633500	1
1-34x	ES709806	Micro SW. 5A 250V(SEMKO)	2214033600	1
1-35x	ES709817	Micro SW. 5A 250V (BSI)	2214035100	2

2) ASSEMBLY BLOCK (2)

Ref. No.	Parts No.	Description	Schematic No.	Q'ty
CABINET BLOCK				
2-1	ZG709132	Panel Spring (A) (Cone Type) AP-001/C	2070382700	1
2-2	ZG709143	Panel Spring (B) BLUE (Cone Type) AP-001/C	2070382800	1
2-3	ZG709154	Panel Spring (C) BLACK (Cone Type) AP-001/C	2070382900	1
2-4	ZG709165	Panel Spring (D) RED (Cone Type) AP-001/C	2070383000	1
2-5	ZS712135	Tapping Screw, pan head 40x8		4
2-6	TP720314	Cushion	2088180700	4
2-7	TP720268	Holder Plate	2074690000	1
2-8	ZS720281	Screw, w/washer 3x10 (Special)	2079477900	1
2-9	TP720270	Rubber Pad A	2088180400	2
2-10	TP720292	Rubber Pad B	2088180500	1
2-11	TP720303	Rubber Pad C	2088180600	1
SPEED CHANGE BRACKET BLOCK				
2-12	BZ709312	Speed Changing Bracket Block Comp. AP-001/C	2073564800	1
2-13	ZG718918	Turn-over Spring AP-003	2277172000	1
2-14	ZS712225	Tapping Screw, pan head 30x8		2
2-15	SB631157	Push Button E	CW-2014	2
RECORD SELECT CAM BLOCK				
2-16	TP709558	Connecting Pole AP-001/C	2076468800	1
2-17	TP709560	SW. Holder AP-001/C	2074687000	1
2-18	ZG709571	Pull Coil Spring AP-001/C	227178200	1
2-19	ZW713586	Special Washer, 32x100x5	2270351000	2
2-20	ZS715228	Tapping Screw, pan head 30x10		1
2-21	ES711786	Reed SW.	2214632200	1
2-22	BD709582	PU Plate Block Comp. AP-001/C	2075179500	1
2-23	ZS715230	Screw, countersunk head 26x8 (PC)		1
ELECTRICAL PARTS BLOCK				
2-24	EJ709593	Output Terminal Plate AP-001/C	2216235000	1
2-25x	EW709604	PU Cord AP-001/C	2216434700	1
2-26	TP709727	Spacer AP-001/C	2275289400	4
2-27	ZS715241	Tapping Screw 3x16 BR		4
2-28	MB718885	Cushion Rubber AP-003	2088161000	4
2-29	BT709751	Power Trans. (U/T, 110/220)/KMA	2222332800	1
2-30x	BT709762	Power Trans. (U/T, 240/50)/AST, BSI	2222334100	1
2-31x	BT709773	Power Trans. CEE (SEMKO)	2222334300	1
2-32x	BT709784	Power Trans. CSA	2222334400	1
2-33	TP711011	Cord Retainer	2074679000	1
2-34x	TP711022	Cord Retainer	2074682600	1
2-35	TP712001	Cord Stopper UL	2088167600	1
2-36x	TP712012	Cord Stopper 3 Core	2218512600	1
2-37x	TP709795	Cord Stopper KMA, CEE (SEMKO)	2218512900	1
2-38	BA709828	P.C Board Comp. (U/T, 110/220)/KMA AP-001/C	R-030207	1
2-39x	BA709830	P.C Board Comp. (U/T, 240/50)/AST AP-001/C	R-030227	1
2-40x	BA709841	P.C Board Comp. CSA AP-001/C	R-030226	1
2-41x	BA709852	P.C Board Comp. CEE (SEMKO)	R-030225	1
2-42x	BA709863	P.C Board Comp. BSI AP-001/C	R-030228	1
2-43	ET709874	Transistor 2SD198 (Q)	2211444000	1
2-44	ET709885	Transistor 2SC1446 (Q)	2211444100	1
2-45	ED709896	Diode 1S1887	3756870000	4
2-46	EC709907	Metalized/C. 0.047μF 1000V	22370139900	1
2-47	EC709918	Metalized/C. 0.1μF AC125V	2237014700A	1

When ordering parts, Please describe Parts Number, Serial Number, and Model Number in detail.

Ref. No.	Parts No.	Description	Schematic No.	Q'ty
2-48x	EC709920	Metalized/C. 0.047 μ F AC250V	2233011400	1
2-49	EF711966	Fuse 1A 250V	2214422400	1
2-50x	EF709931	Fuse 0.5A(T)	2214419200	1
2-51x	EJ709942	Fuse Holder AP-001/C	2216504700	2
2-52	ES712078	Seesaw SW.	2214649400	1
2-53x	ZW709953	Nut 3M (AP-001/C)		1
2-54x	ZW709964	Spring Washer 3M Small AP-001/C		1
2-55x	ZW709975	Spring Washer 3M Large AP-001/C		1
2-56	EW711955	AC Cord 2.5M UL	2217619900	1
2-57x	EW711990	AC Cord 2.5M 3 Core, SAA	2217705100	1
2-58x	EW709986	AC Cord KMA AP-001/C	2217652400	1
2-59x	EW709997	AC Cord BSI AP-001/C	2217706900	1
2-60x	EW710065	AC Cord CEE (SEMKO) AP-001/C	2217652500	1
2-61x	EW710741	AC Cord AST	2217653100	1

When ordering parts, Please describe Parts Number, Serial Number, and Model Number in detail.

3. PHOTO OF CABINET BLOCK



3) CABINET BLOCK

Ref. No.	Parts No.	Description	Schematic No.	Q'ty
3-1	BC709007	Cabinet AP-001	208477510	1
3-2x	BC709121	Cabinet AP-001C	208477690	1
3-3	TP719853	Hinge A AP-003	208616870	2
3-4x	ZS711808	Tapping Screw, pan head 30x10		6
3-5	BC709233	Dust Cover Block Comp. AP-001/C	208478210	1
3-6	TP719897	Hinge B AP-003	208616880	2
3-7	ZS712214	Screw, oval countersunk head 40x10		4
3-8	SP709244	Bottom Case AP-001/C	208466110	1
3-9x	SA718762	Foot (Rubber) AP-003	228745120	4
3-10x	TP709266	Lock Plate AP-001/C	207546020	3
3-11x	ZS718637	Screw (Special), w/washer 4x12	207959270	3
3-12x	TP720246	Vinyl Sheet	209436780	3

INDEX

Parts No.	Ref. No.	Parts No.	Ref. No.	Parts No.	Ref. No.	Parts No.	Ref. No.	Parts No.	Ref. No.
BA709828	2-38	TP720314	2-6						
BA709830	2-39x	ZG709132	2-1						
BA709841	2-40x	ZG709143	2-2						
BA709852	2-41x	ZG709154	2-3						
BA709863	2-42x	ZG709165	2-4						
BC709007	3-1	ZG709470	1-17x						
BC709121	3-2x	ZG709571	2-18						
BC709233	3-5	ZG718918	2-13						
BD709582	2-22	ZS711808	3-4x						
BL709536	1-30	ZS712135	2-5						
BL719381	1-15	ZS712214	3-7						
BM709356	1-6	ZS712225	2-14						
BT709751	2-29	ZS712372	1-21x						
BT709762	2-30x	ZS712653	1-22x						
BT709773	2-31x	ZS712765	1-28						
BT709784	2-32x	ZS715228	2-20						
BZ709312	2-12	ZS715230	2-23						
BZ709323	1-3	ZS715241	2-27						
BZ709481	1-19	ZS718637	3-11x						
BZ709547	1-32	ZS720281	2-8						
EC709907	2-46	ZW709953	2-53x						
EC709918	2-47x	ZW709964	2-54x						
EC709920	2-48x	ZW709975	2-55x						
ED709896	2-45	ZW712236	1-13						
EF709931	2-50x	ZW712361	1-18x						
EF711966	2-49	ZW712697	1-27						
EJ709593	2-24	ZW713586	2-19						
EJ709942	2-51x	ZW719043	1-26						
ES709806	1-34x								
ES709817	1-35x								
ES711786	2-21								
ES712078	2-52								
ES718648	1-33								
ET709874	2-43								
ET709885	2-44								
EW709604	2-25x								
EW709986	2-58x								
EW709997	2-59x								
EW710065	2-60x								
EW710741	2-61x								
EW711955	2-56								
EW711990	2-57x								
MB709391	1-7								
MB718885	2-28								
MB719008	1-5								
MR709402	1-8								
MR709413	1-9x								
MS709424	1-10								
MS709435	1-11								
MS709468	1-16								
MS709525	1-29								
MV709514	1-25								
SA718762	3-9x								
SB631157	2-15								
SK715533	1-31								
SP709244	3-8								
TP709266	3-10x								
TP709334	1-4								
TP709446	1-12								
TP709457	1-14								
TP709492	1-23								
TP709503	1-24								
TP709558	2-16								
TP709560	2-17								
TP709727	2-26								
TP709795	2-37x								
TP710021	1-1								
TP711011	2-33								
TP711022	2-34x								
TP712001	2-35								
TP712012	2-36x								
TP719594	1-20								
TP719853	3-3								
TP719897	3-6								
TP720246	3-12x								
TP720257	1-2								
TP720268	2-7								
TP720270	2-9								
TP720292	2-10								
TP720303	2-11								

1. ILLUSTRATION OF ASSEMBLY BLOCK (1)

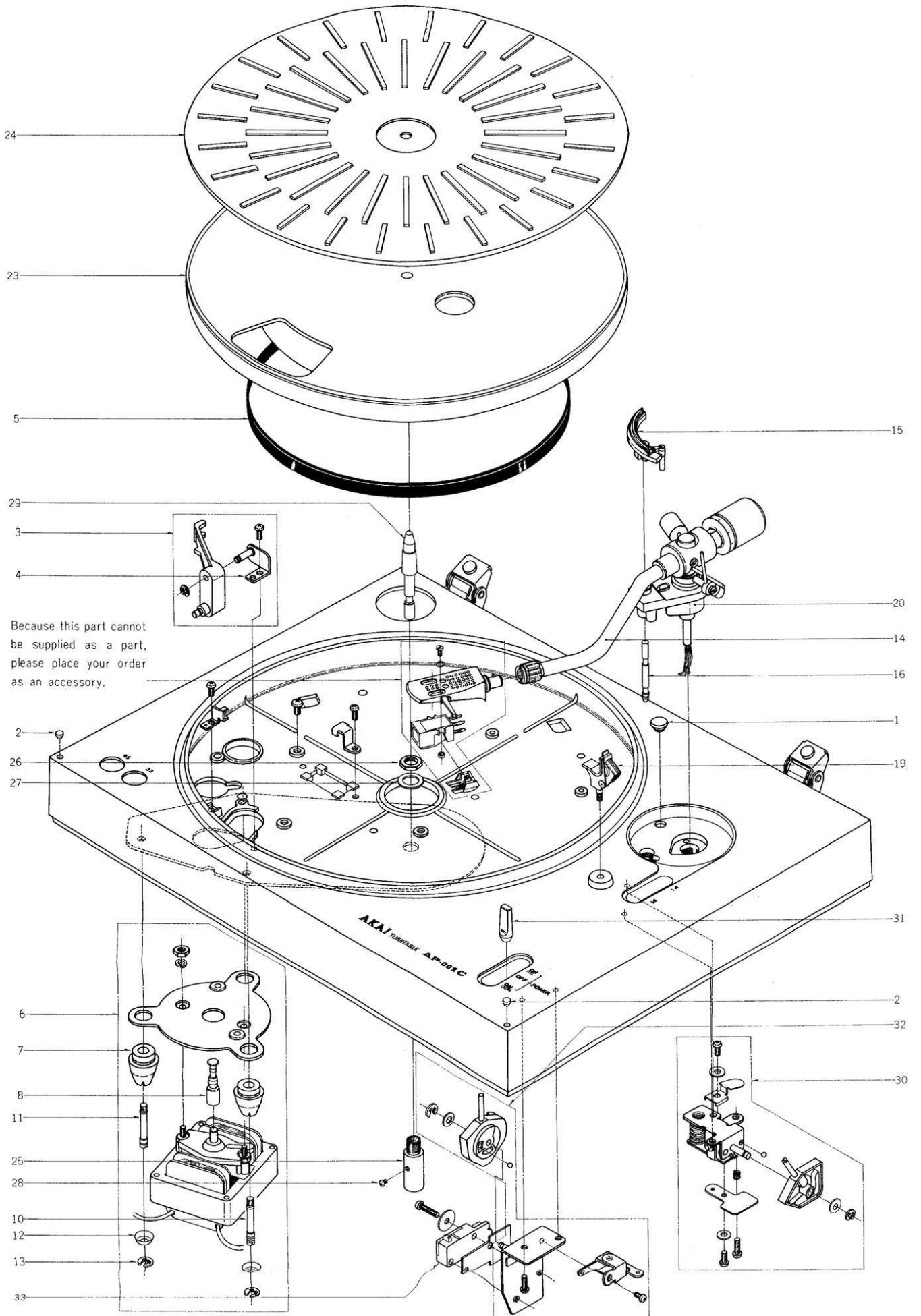

2. ILLUSTRATION OF ASSEMBLY BLOCK (2)

