

AA-5210

SERVICE MANUAL

PARTS LIST



AKAI STEREO AMPLIFIER

MODEL **AA-5210**

ALSO APPLICABLE TO MODEL AA-5210DB

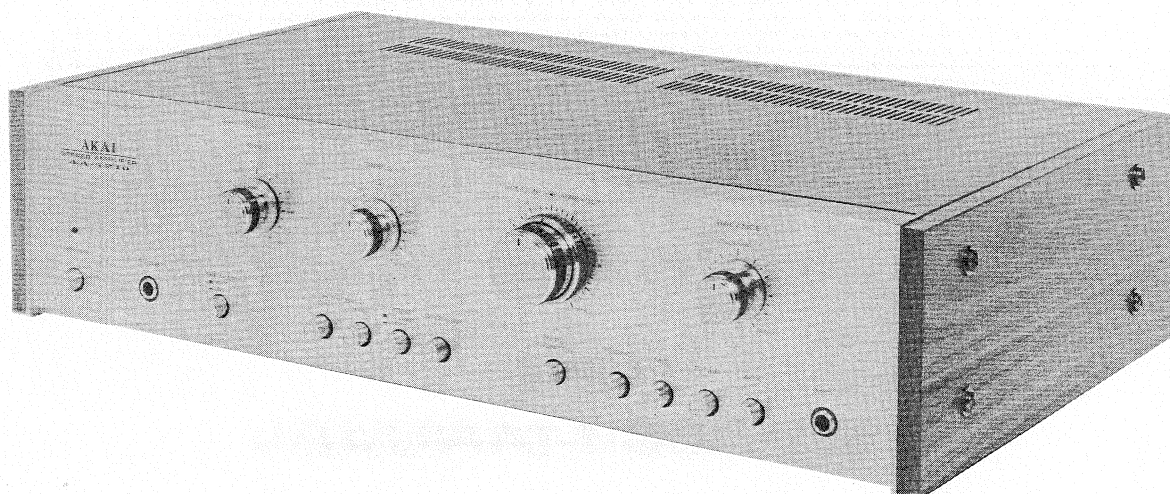

STEREO AMPLIFIER

MODEL **AA-5210**

ALSO APPLICABLE TO MODEL AA-5210DB
STEREO AMPLIFIER

SECTION 1 SERVICE MANUAL	2
SECTION 2 PARTS LIST	13
SECTION 3 SCHEMATIC DIAGRAM	28

SECTION 1

SERVICE MANUAL

TABLE OF CONTENTS

I.	SPECIFICATIONS	3
II.	DISMANTLING OF UNIT	4
III.	ADJUSTMENTS.....	5
	1. NECESSARY MEASURING INSTRUMENTS	5
	2. CLASSIFICATION OF VARIOUS P.C. BOARDS	5
	3. DOLBY N.R. ADJUSTMENT	5
	4. MAIN AMP. ADJUSTMENT	7
IV.	COMPOSITE VIEWS OF COMPONENTS	10

I. SPECIFICATIONS

An asterisk next to a figure indicates the minimum guaranteed performance.

RATED OUTPUT		15W x 2/8Ω (both channels activated)
HARMONIC DISTORTION		0.5% (8Ω) at rated output
POWER BAND WIDTH (IHF)		15 to 80,000 Hz *20 to 50,000 Hz at 1% distortion
INPUT SENSITIVITY	PHONO	2.75 mV (-49 dBm ±1.5 dB)
	MIC	2.75 mV (-49 dBm ±1.5 dB)
	TUNER	0.85 mV (-59 dBm ±1.5 dB) ... AA-5210DB
	AUX	155 mV (-14 dBm ±1.5 dB)
	TAPE	155 mV (-14 dBm ±1.5 dB)
RESIDUAL NOISE		Less than 1.4 mV (Less than -55 dBm)
SIGNAL TO NOISE RATIO	PHONO	Better than 37 dBm input shorted
	MIC	Better than 37 dBm input shorted
	TUNER	Better than 47 dBm input open
	AUX	Better than 47 dBm input open
	TAPE	Better than 47 dBm input open
TONE CONTROL	BASS	10 ±1.5 dB at 100 Hz -10 ±1.5 dB at 100 Hz
	TREBLE	10 ±1.5 dB at 10 kHz -10 ±1.5 dB at 10 kHz
LOUDNESS CONTROL		7 ±1.5 dB at 100 Hz 5 ±1.5 dB at 10 kHz
PHONO FREQUENCY RESPONSE		RIAA ±1 dB *13 ±1.5 dB at 100 Hz *-14 ±1.5 dB at 10 kHz
CHANNEL SEPARATION		Better than 50 dB at 1 kHz
L-R DEVIATION		Within 2 dB
RECORDING OUTPUT	PIN	140 mV (-15 ±1.5 dB)
	DIN	27 mV (-29 ±1.5 dB)
TRANSISTORS		2SA628 (E) (F) ... 0 (4) 2SC1312 (G) (H) ... 6 (6) 2SA720 (P) (Q) ... 2 (2) 2SC1312R (G) (H) ... 0 (10) 2SA725 (G) ... 2 (2) 2SC1313(F) (G) (H) ... 4 (2) 2SC711 (E) (F) (G) ... 0 (8) 2SC1318 (P) (Q) ... 4 (4) 2SC1061 (B) (C) ... 4 (4) 2SD313 (E) (F) ... 0 (1) 2SC1247A (B)(V) ... 1 (0) 2SD361 (D) (E) ... 0 (1)
F.E.T.		2SK30A (GR) ... 0 (2)
DIODES	10D-1 ... 0 (4) 1N4002 ... 4 (0)	
	HIFI SPECIAL 400V 3A ... 4 (4) 1S2473VE ... 0 (6)	
	1N34A ... 0 (8) ZW085 ... 0 (2)	
	ZW240 ... 0 (1)	
THERMISTERS		24D26 ... 0 (1)
VARISTORS		VD1222 ... 2 (2)
POWER SOURCE		100 to 240V A.C. 50/60 Hz
POWER CONSUMPTION		120W ... AA-5210, 150W ... AA-5210DB
DIMENSIONS		450(W) x 108(H) x 290(D) mm ... AA-5210 (17.7" x 4.2" x 11.4") 529(W) x 108 (H) x 340(D) mm ... AA-5210DB (20.8" x 4.3" x 13.4")
WEIGHT	7.2 kg (15.8 lbs.) ... AA-5210	
	9.6 kg (21.1 lbs.) ... AA-5210DB	

- NOTES: 1. The Transistors, F.E.T. Diodes, Thermistors and Varistors for model AA-5210DB are shown in parentheses.
2. Specifications subject to change without notice.

II. DISMANTLING OF UNIT

In case of trouble, etc. necessitating disassembly, please disassemble in the order shown in photographs. Reassemble in reverse order.

1

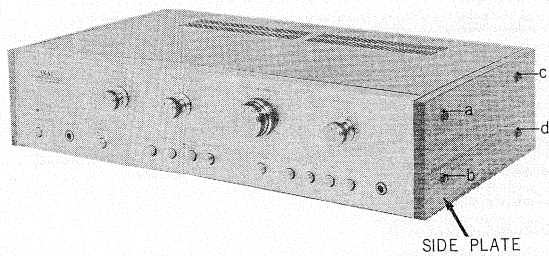

2

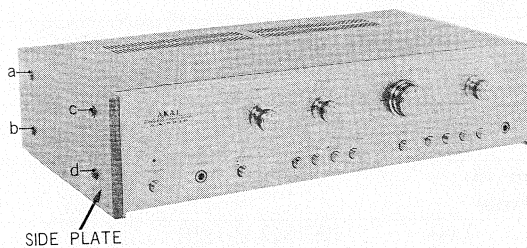

3

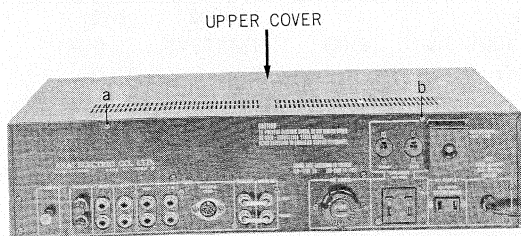

4

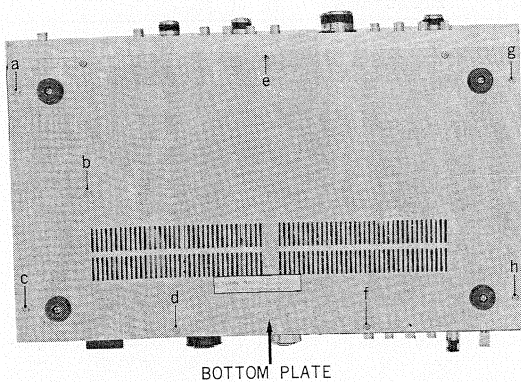

5

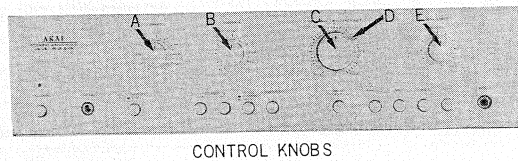

6

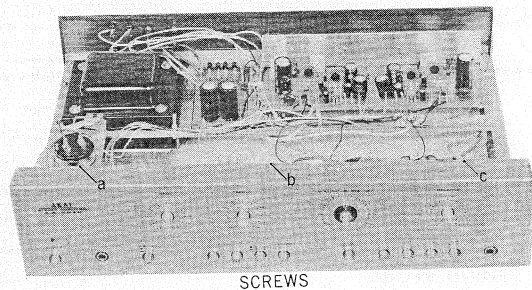

7

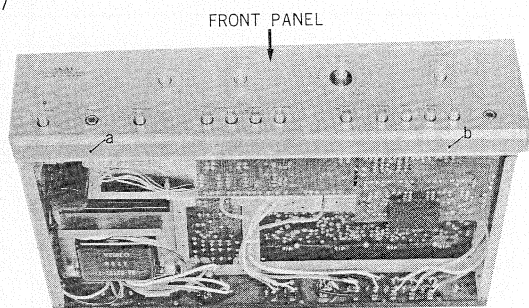

8

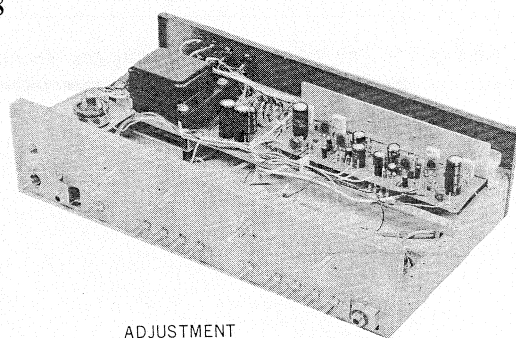

III. ADJUSTMENT

1. NECESSARY MEASURING INSTRUMENT

Measuring Instruments	Model	For
HIGH SENSITIVITY A.C. VOLTMETER	Kikusui 183E	DOLBY N.R. ADJUSTMENT
RC OSCILLATOR	Kikusui 418	
FREQUENCY COUNTER	National VP-475	
AMPERE METER OR TESTER	Yokogawa 2011	MAIN AMP. ADJUSTMENT
V.T.V.M. or Tester	Kikusui 107A	
Oscilloscope		

2. CLASSIFICATION OF VARIOUS P.C. BOARDS

P.C. Board	AA-5210	AA-5210DB
MAIN AMP. P.C. BOARD	96-5008	96-5008
EQUALIZER P.C. BOARD	A5-5028	A5-5083
TONE CONTROL P.C. BOARD	A5-5029	A5-5029
POWER SUPPLY P.C. BOARD	A5-5026	A5-5047
SWITCH P.C. BOARD	A5-5061	A5-5045
SPEAKER SW. P.C. BOARD	A5-5027	
DOLBY N.R. P.C. BOARD		A5-5046

3. DOLBY N.R. ADJUSTMENT

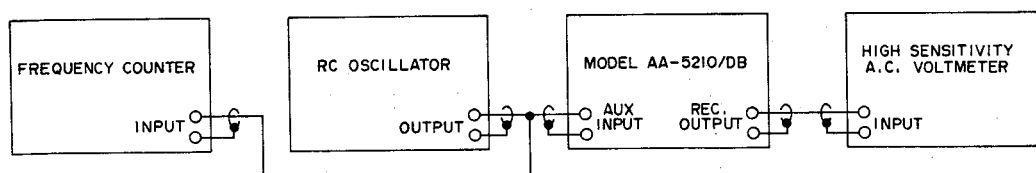

Fig. 1

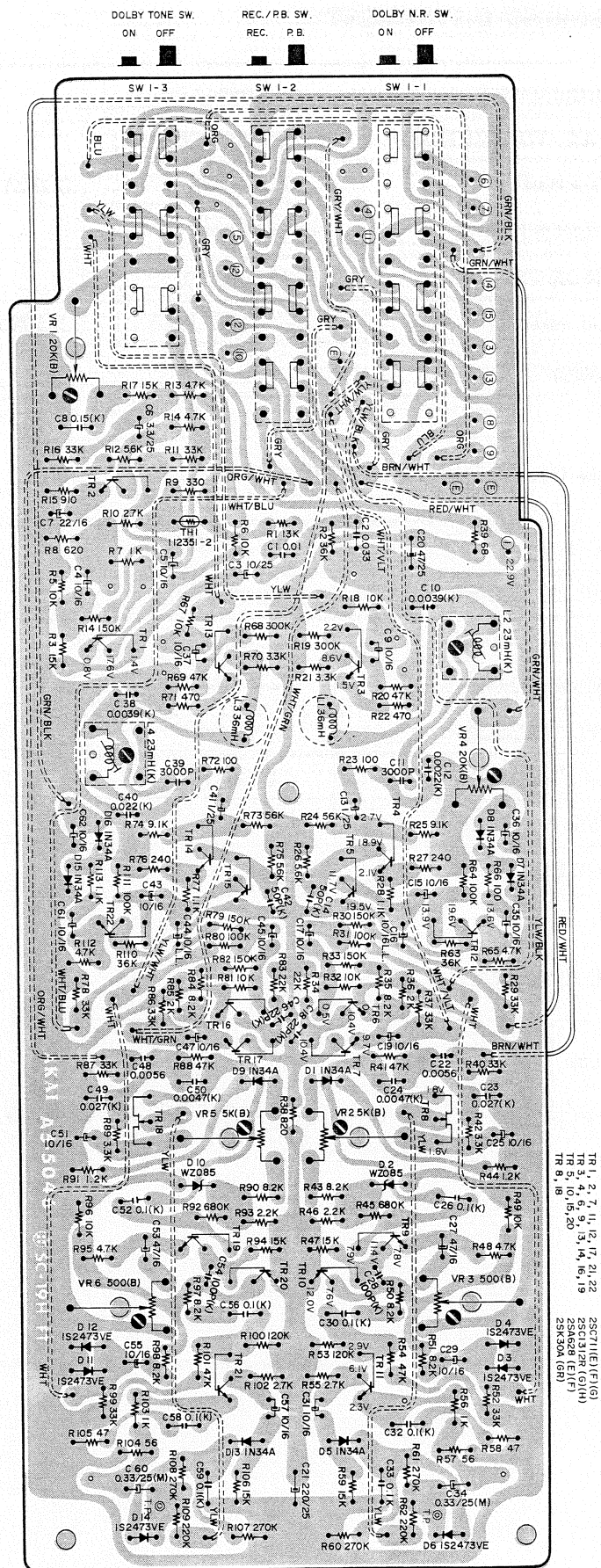

Fig. 2 DOLBY N.R. P.C. BOARD A5-5046 (reverse side)

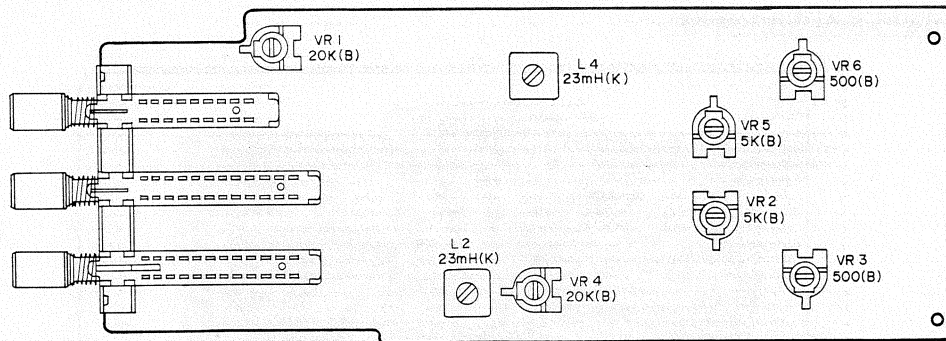

Fig. 3 DOLBY N.R. P.C. BOARD A5-5046 (face side)

DOLBY N.R. ADJUSTMENT

Adjustment Item	Adjustment Point	Reference Diagram	Remarks
19 KHz filter Adjustment	L2 (left channel), L4 (right channel) 23 mH	Figs. 1, 3	Adjust level of 19 KHz signal supplied to "Aux" to minimum.
REC. Mode Adjustment	VR3 (left channel), VR6 (right channel) 500 (B)	Figs. 1,2,3	With both semi-fixed volumes at maximum, ground T.P. and supply a 5 KHz signal to "AUX" and set output to -28.5 dB. Set Dolby SW. to ON and adjust for a 10 dB output increase.
	VR2 (left channel), VR5 (right channel) 5k (B)	Figs. 1,2,3	Disconnect T.P. from ground and adjust output to -20.5 dB.
Dolby Tone Level Adjustment	VR1 20k(B)	Fig. 3	Adjust to obtain right channel level meter indication of 0 VU.
Level Meter Sensitivity Adjustment	VR4 20k(B)	Fig. 3	Adjust to obtain left channel level meter indication of 0 VU.

NOTE: For Dolby Noise Reduction System operating principles, please refer to GENERAL OPERATING PRINCIPLES AND ADJUSTMENTS FOR AKAI TAPE RECORDERS AND TUNER AMPLIFIERS.

4. MAIN AMP. ADJUSTMENT

(1) IDLING CURRENT ADJUSTMENT

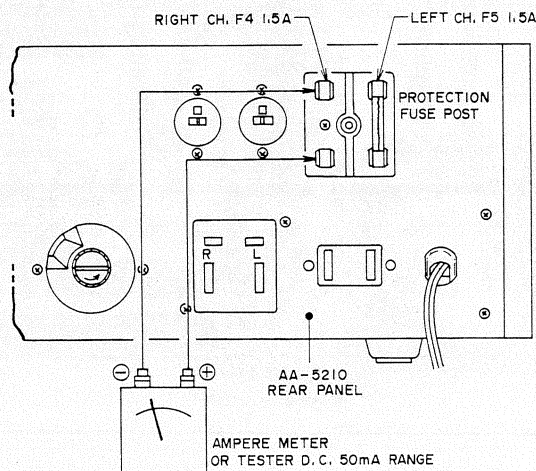

Fig. 4

(2) D.C. BALANCE ADJUSTMENT

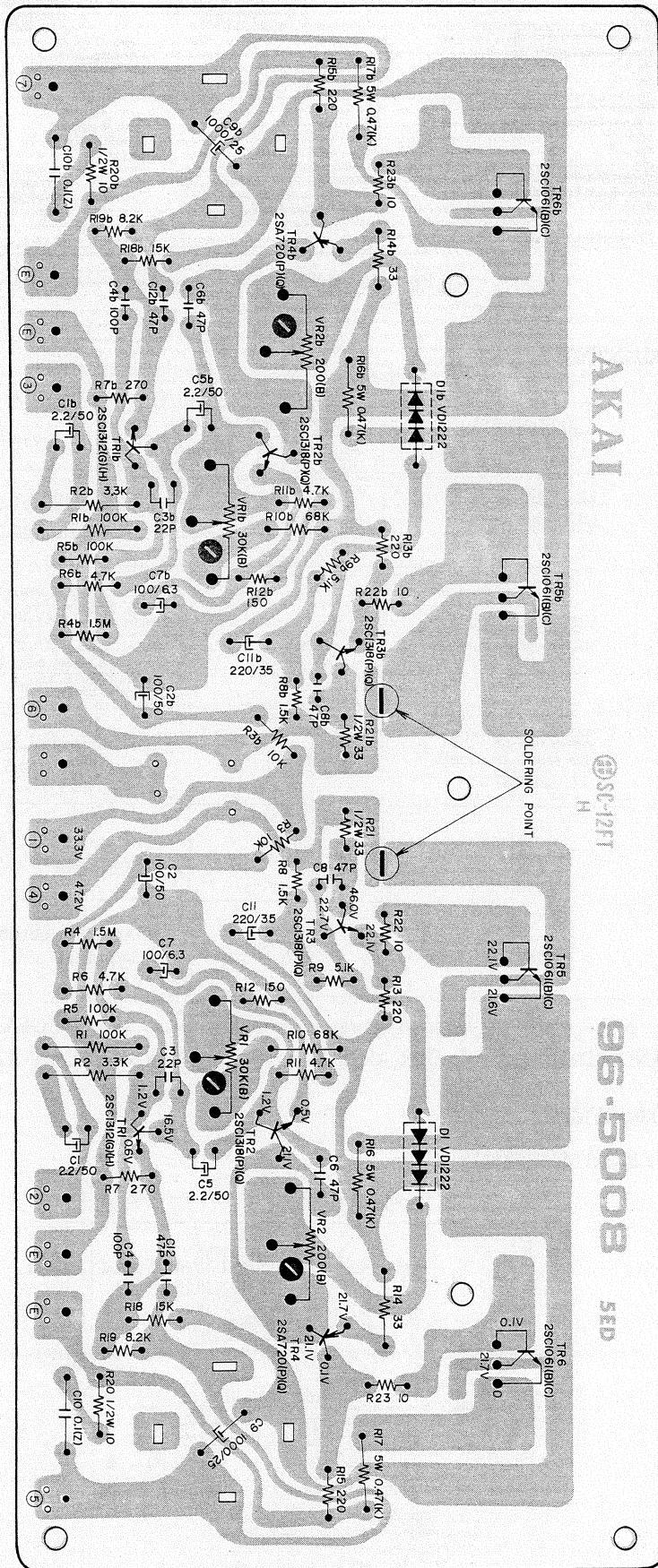

Fig. 5 MAIN AMP. P.C. BOARD 96-5008 (reverse side)

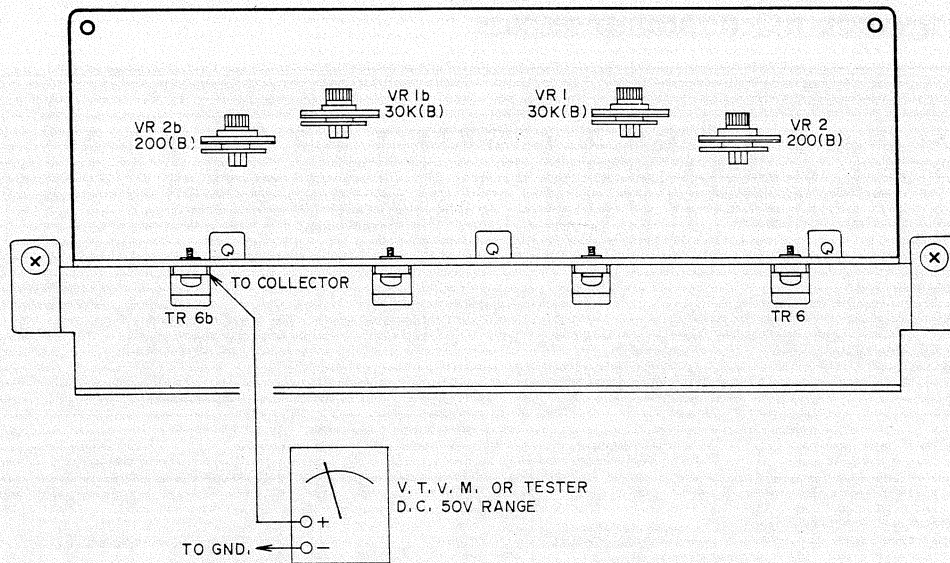

Fig. 6 MAIN AMP. P.C. BOARD 96-5008 (face side)

MAIN AMPLIFIER ADJUSTMENT

Adjustment Item	Adjustment Point	Reference Diagram	Remarks
IDLING CURRENT ADJUSTMENT	VR2, 2b 200(B)	Fig. 4	Adjust so that idling current is 25 to 30 mA.
D.C. BALANCE ADJUSTMENT	VR1, 1b 30k(B)	Figs. 5, 6	Adjust so that measured voltage is 1/2 the value of supply voltage.

IV. COMPOSITE VIEWS OF COMPONENTS

1. TONE CONTROL P.C. BOARD A5-5029

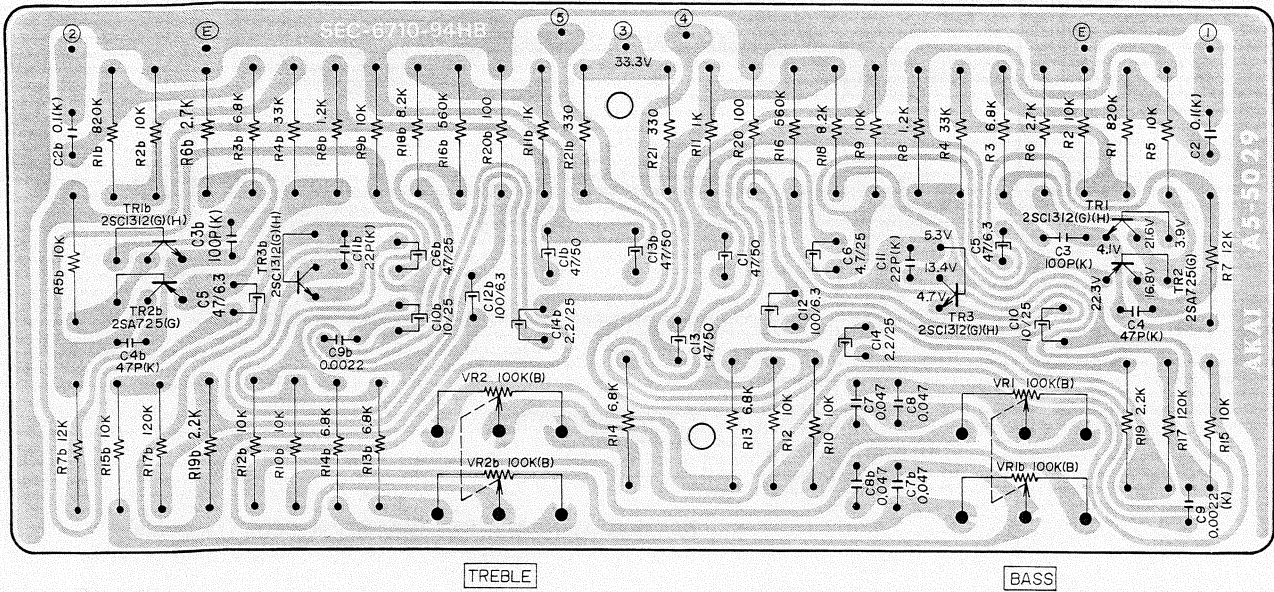

2. EQUALIZER P.C. BOARD A5-5028

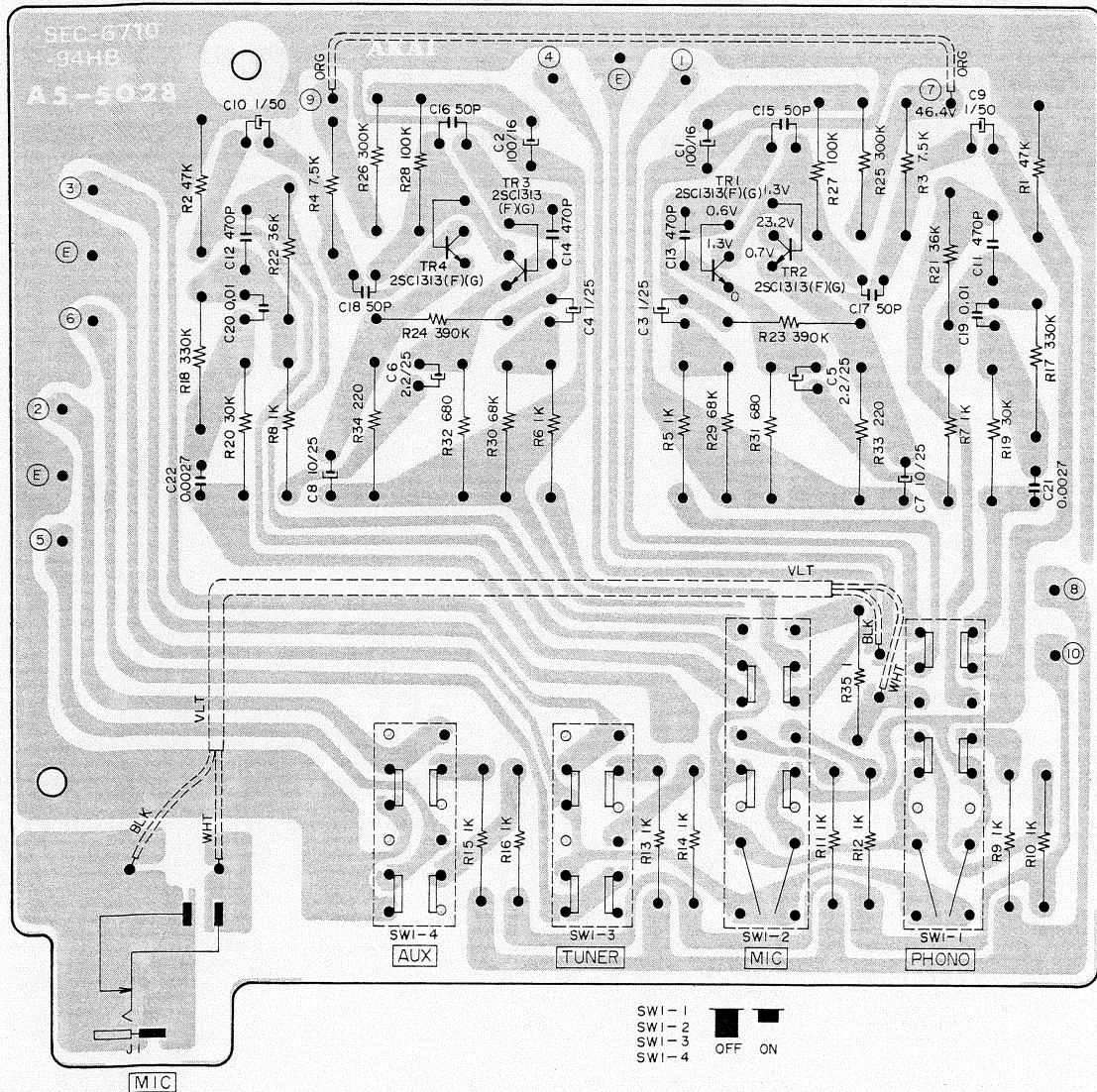

3. EQUALIZER P.C. BOARD A5-5083

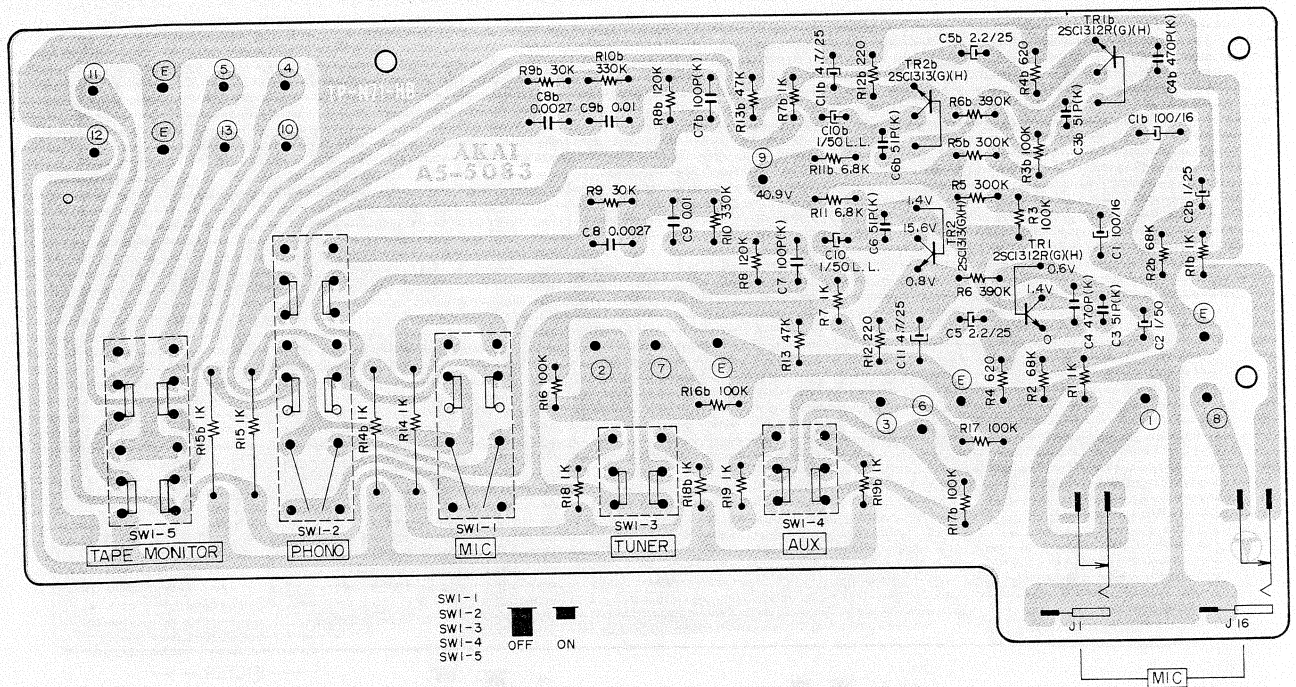

4. POWER SUPPLY P.C. BOARD A5-5047

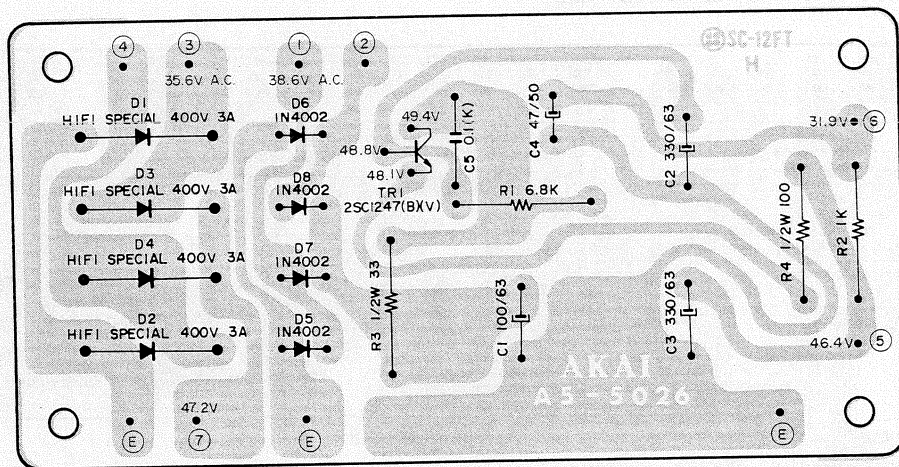

5. POWER SUPPLY P.C. BOARD A5-5047 (DB)

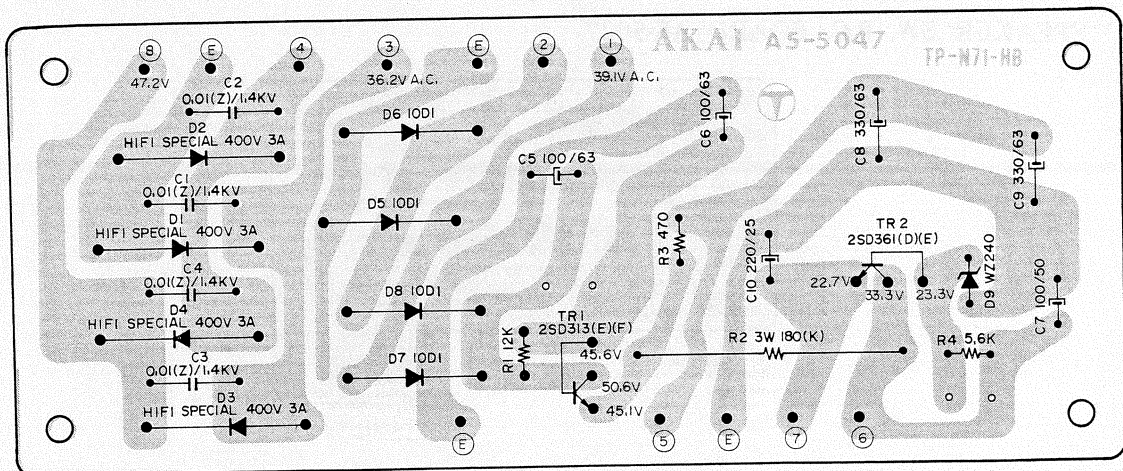

6. SW. P.C. BOARD A5-5061

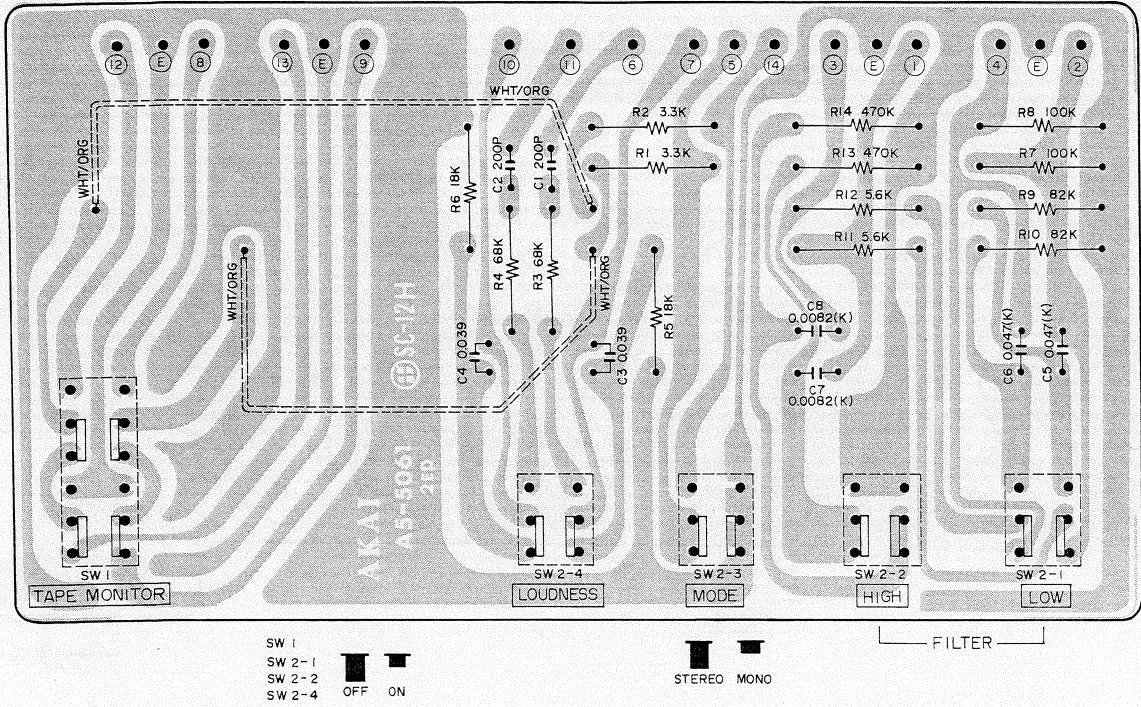

7. SW. P.C. BOARD A5-5061 (DB)

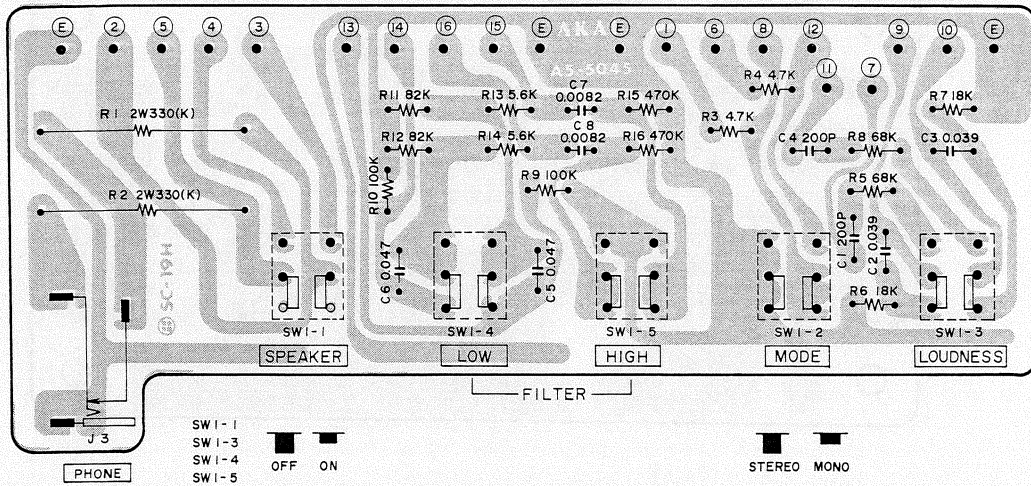

8. SPEAKER SW. P.C. BOARD A5-5027

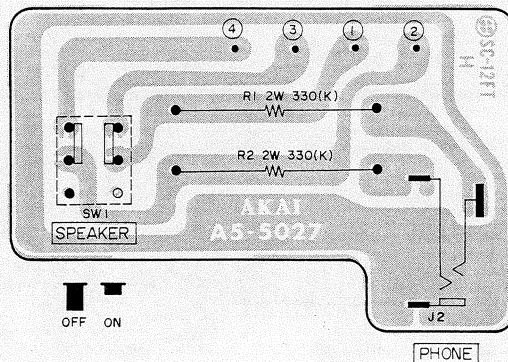

SECTION 2

PARTS LIST

TABLE OF CONTENTS

Fig. 1	MAIN AMP. P.C. BOARD (96-5008) BLOCK	16
Fig. 2	TONE CONTROL P.C. BOARD (A5-5029) BLOCK	17
Fig. 3	EQ. P.C. BOARD (A5-5028) BLOCK	18
Fig. 4	EQ. P.C. BOARD (A5-5083) BLOCK	19
Fig. 5	POWER SUPPLY P.C. BOARD (A5-5026) BLOCK	20
Fig. 6	POWER SUPPLY P.C. BOARD (A5-5047) BLOCK	20
Fig. 7	SW. P.C. BOARD (A5-5061) BLOCK	21
Fig. 8	SW. P.C. BOARD (A5-5045) BLOCK	21
Fig. 9	SPEAKER SW. P.C. BOARD (A5-5027) BLOCK	22
Fig. 10	DOLBY P.C. BOARD (A5-5046) BLOCK	22
Fig. 11	ASSEMBLY BLOCK	24
Fig. 12	FINAL ASSEMBLY BLOCK	26
INDEX	27

HOW TO USE THIS PARTS LIST

1. This parts list is compiled by various individual blocks based on assembly process.
2. When ordering parts, please describe parts number, serial number, and model number in detail.
3. How to read list.

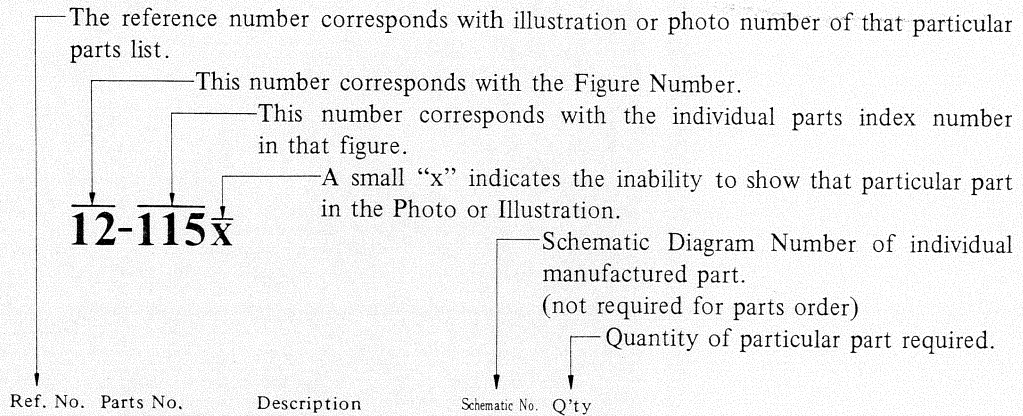

Ref. No.	Parts No.	Description	Schematic No.	Q'ty
FLYWHEEL BLOCK #13				
12-115x	800425	Flywheel Block Assy. Comp.	RDG #13	1
12-116	244506	Flywheel Only	RD-233	1
12-117x	244754	Felt, Flywheel	RD-275	1
12-118	251324	Main Metal Case	RD-236	1
12-119	253080	Main Metal	RD-237	1

4. The symbol numbers shown on the P.C. Board list can be matched with the Composite Views of components of the Schematic Diagram or Service Manual.
5. The indications of Resistors and Capacitors in the photos of P.C. Board are being eliminated.
6. The shape of the parts and parts name, etc. can be confirmed by comparing them with the parts shown on the Electrical Parts Table of P.C. Board.
7. Please utilize separate "Common List for Service Parts" for Resistor parts orders.
8. Both the kind of part and installation position can be determined by the Parts Number. To determine where a parts number is listed, utilize Parts Index at end of Parts List.
It is necessary first of all to find the Parts Number. This can be accomplished by using the Reference Number listed at right of parts number in the Parts Index. (meaning of ref. no. outlined in Item 3 above).
9. Utilize separate "Price List for Parts" to determine unit price. The most simple method of finding parts Price is to utilize the reference number.

ELECTRICAL PARTS TABLE

<p>Because the indication of resistors and capacitors in the P. C. Board photos are being eliminated, please confirm parts name and shape by comparing them with the parts shown in this table.</p>	<p style="text-align: center;">1</p>  <p style="text-align: center;">Solid Resistor</p>	<p style="text-align: center;">2</p> <p style="text-align: right;">Stopper Type</p>  <p style="text-align: center;">Insulator Type</p> <p style="text-align: center;">Carbon Resistor</p>	<p style="text-align: center;">3</p>  <p style="text-align: center;">Metal Oxide Film Resistor</p>
<p style="text-align: center;">4</p>  <p style="text-align: center;">Cement Resistor</p>	<p style="text-align: center;">5</p>  <p style="text-align: center;">Wire-Wound Resistor</p>	<p style="text-align: center;">6</p>  <p style="text-align: center;">Thermister</p>	<p style="text-align: center;">7</p>  <p style="text-align: center;">Enamel Resistor</p>
<p style="text-align: center;">1</p>  <p style="text-align: center;">MP Capacitor (Tubular Type)</p>	<p style="text-align: center;">2</p>  <p style="text-align: center;">Plastic Capacitor</p>	<p style="text-align: center;">3</p>  <p style="text-align: center;">Mylar Capacitor</p>	<p style="text-align: center;">4</p>  <p style="text-align: center;">VFM (Hi-Q) Capacitor</p>
<p style="text-align: center;">5</p>  <p style="text-align: center;">Mylar Capacitor</p>	<p style="text-align: center;">6</p>  <p style="text-align: center;">Tantalum Capacitor</p>	<p style="text-align: center;">7</p>  <p style="text-align: center;">Oil Capacitor (Tubular Type)</p>	<p style="text-align: center;">8</p> <p style="text-align: right;">Vertical Type</p> <p>(Tubular Type)</p>  <p style="text-align: center;">Styrol Capacitor</p>
<p style="text-align: center;">9</p>  <p style="text-align: center;">Electrolytic Capacitor (Tubular Type)</p>	<p style="text-align: center;">10</p> <p style="text-align: right;">Vertical Type</p> <p>(Tubular Type)</p>  <p style="text-align: center;">Electrolytic Capacitor</p>	<p style="text-align: center;">11</p>  <p style="text-align: center;">Ceramic Capacitor</p>	<p style="text-align: center;">12</p>  <p style="text-align: center;">Metalized Mylar (Paper) Capacitor</p>
<p style="text-align: center;">13</p>  <p style="text-align: center;">Trimmer Condenser</p>		<p style="text-align: center;">VR</p>  <p style="text-align: center;">Semi-Fixed Volume</p>	
<p style="text-align: center;">L</p>  <p style="text-align: center;">Ferri Inductor</p>	<p style="text-align: center;">TR</p>  <p style="text-align: center;">Transistor</p>		
<p style="text-align: center;">CR</p>  <p style="text-align: center;">Spark Quencher</p>	<p style="text-align: center;">D</p>  <p style="text-align: center;">Diode (Silicon, Zener, Germanium)</p>		

FIG. 1 PHOTO OF MAIN AMP. P.C. BOARD (96-5008) BLOCK

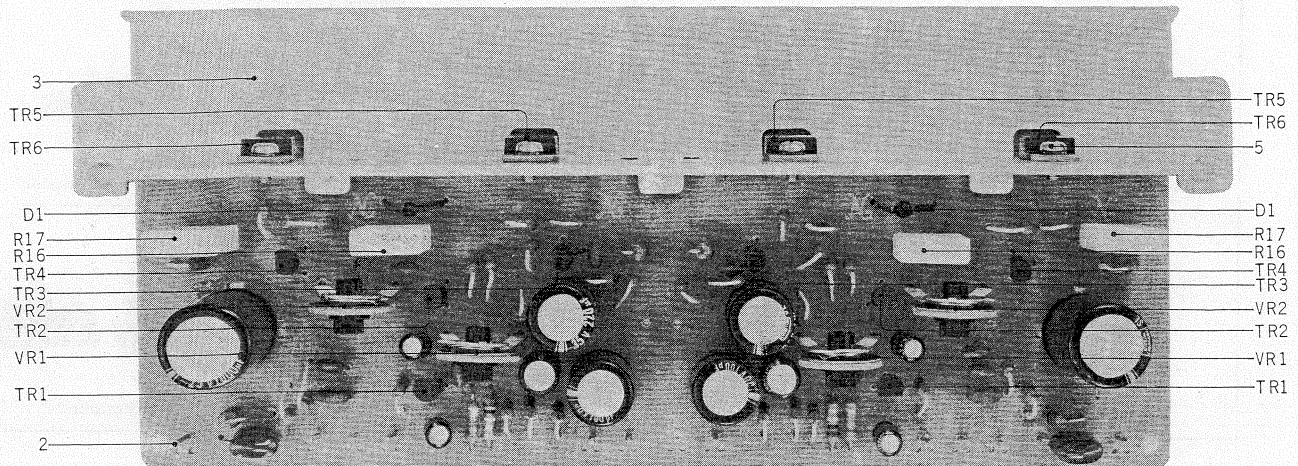

MAIN AMP. P.C. BOARD (96-5008) BLOCK

Symbol No.	Parts No.	Description	Q'ty
1-1x	BA602752	Main Amp. P.C. Board Comp. (96-5008)	1
1-TR1	ET516263	Transistor 2SC1312(G)(H)	2
1-TR2,3	ET562858	Transistor 2SC1318(P)(Q)	4
1-TR4	ET562860	Transistor 2SA720(P)(Q)	2
1-TR5,6	ET375603	Transistor 2SC1061(B)(C)	4
1-D1	ED490511	Varistor VD1222	2
1-VR1	EV383398	Semi-fixed/Vol. V18K3-2 30 kB (4 US)	2
1-VR2	EV221815	Semi-fixed/Vol. V18K3-2 200B (4 US)	2
1-2	EJ539662	Wrapping Post 1x17	11
1-3	EZ605957	Heat-sink	1
1-4	EZ602403	Insulator Washer YN27B	4
1-5	ZS379350	ISO Screw, Pan Head 3x6	4
1-6	ZS325495	Tapping Screw #2 3x6	3
1-R16,17	ER622978	Metal Plate/R.	4
Capacitor, Vertical Type			
1-C1	EC354947	Elect. 2.2 μ F 50WV	2
1-C2	EC321221	Elect. 100 μ F 50WV	4
1-C3	EC399565	VFM 22PF(J) 50WV	2
1-C4	EC290520	VFM 100PF(J) 50WV	2
1-C5	EC354947	Elect. 2.2 μ F 50WV	2
1-C6	EC377212	VFM 47PF(J) 50WV	2
1-C7	EC336104	Elect. 100 μ F 6.3WV	2
1-C8	EC377212	VFM 47PF(J) 50WV	2
1-C9	EC450270	Elect. 1000 μ F 25WV	2
1-C10	EC398957	Mylar 0.1 μ F(M) 50WV	2
1-C11	EC372148	Elect. 220 μ F 35WV	2
1-C12	EC377212	VFM 47PF(J) 50WV	2
Carbon Resistor Omitted			

FIG. 2 PHOTO OF TONE CONTROL P.C. BOARD (A5-5029) BLOCK

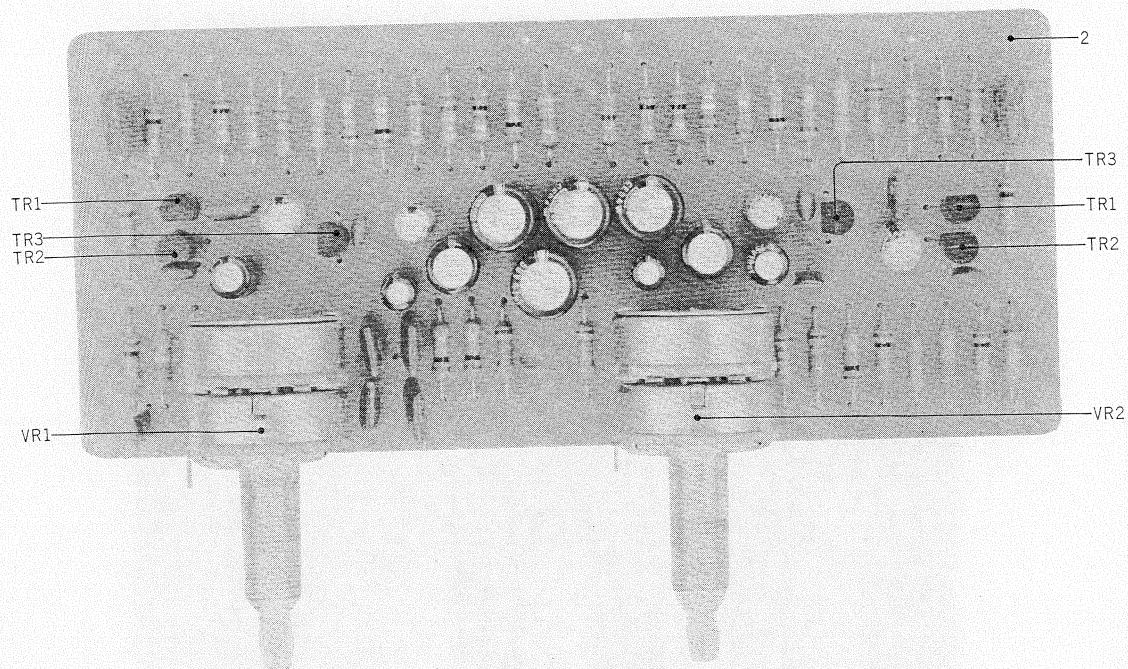

**TONE CONTROL P.C. BOARD
(A5-5029) BLOCK**

Symbol No.	Parts No.	Description	Q'ty
2-1x	BA602807	Tone Control P.C. Board Comp. (A5-5029)	1
2-TR1	ET517263	Transistor 2SC1312(G)(H)	2
2-TR2	ET555952	Transistor 2SA725(G)	2
2-TR3	ET517263	Transistor 2SC1312(G)(H)	2
2-VR1,2	EV602458	Co-axial 2-Throw Vol.(w/click) V24L5GPHN 1kB 100kx2	2
2-2	EJ539662	Wrapping Post 1x17	7
Capacitor, Vertical Type			
2-C1	EC346735	Elect. 47 μ F 50WV	2
2-C2	EC251291	Mylar 0.1 μ F(K) 50WV	2
2-C3	EC290531	VFM 100PF(K) 50WV	2
2-C4	EC487394	VFM 47PF(K) 50WV	2
2-C5	EC329771	Elect. 47 μ F 6.3WV	2
2-C6	EC450527	Elect. 4.7 μ F 25WV	2
2-C7, 8	EC379214	Mylar 0.047 μ F(J) 50WV	4
2-C9	EC250716	Mylar 0.0022 μ F(K) 50WV	2
2-C10	EC220994	Elect. 10 μ F 25WV	2
2-C11	EC556525	FM 22PF(K) 500WV	2
2-C12	EC336104	Elect. 100 μ F 6.3WV	2
2-C13	EC346735	Elect. 47 μ F 50WV	2
2-C14	EC220432	Elect. 2.2 μ F 25WV	2
Carbon Resistor Omitted			

FIG. 3 PHOTO OF EQ. P.C. BOARD (A5-5028) BLOCK

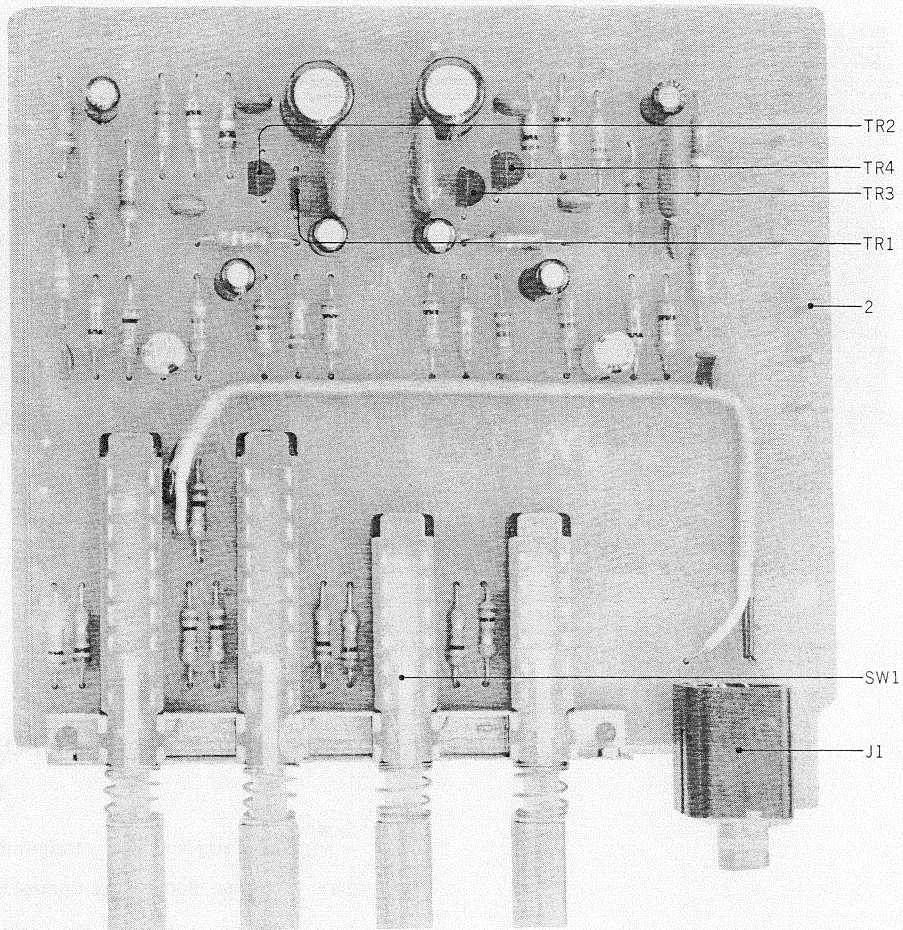

EQ. P.C. BOARD (A5-5028) BLOCK

Symbol No.	Parts No.	Description	Q'ty
3-1x	BA602818	EQ. P.C. Board Comp. (A5-5028)	1
3-TR1to4	ET602460	Transistor 2SC1313(F)(G)(H)	4
3-J1	EJ391094	Mic. Jack 2PMJ1P	1
3-SW1	ES628626	Push SW. 4FTM-0001FF-9920	1
3-2	EJ539662	Wrapping Post 1x17	13
Capacitor, Vertical Type			
3-C1,2	EC220127	Elect. 100 μ F 16WV	2
3-C3,4	EC450055	Elect. 1 μ F 25WV	2
3-C5,6	EC220432	Elect. 2.2 μ F 25WV	2
3-C7,8	EC220994	Elect. 10 μ F 25WV	2
3-C9,10	EC313108	Elect. 1 μ F 50WV	2
3-C11to14	EC423562	VFM 470PF(J) 50WV	4
3-C15to18	EC350616	VFM 50PF(J) 50WV	4
3-C19,20	EC302321	Mylar 0.01 μ F(J) 50WV	2
3-C21,22	EC379765	Mylar 0.002 μ F(J) 50WV	2
Carbon Resistor Omitted			

FIG. 4 PHOTO OF EQ. P.C. BOARD (A5-5083) BLOCK

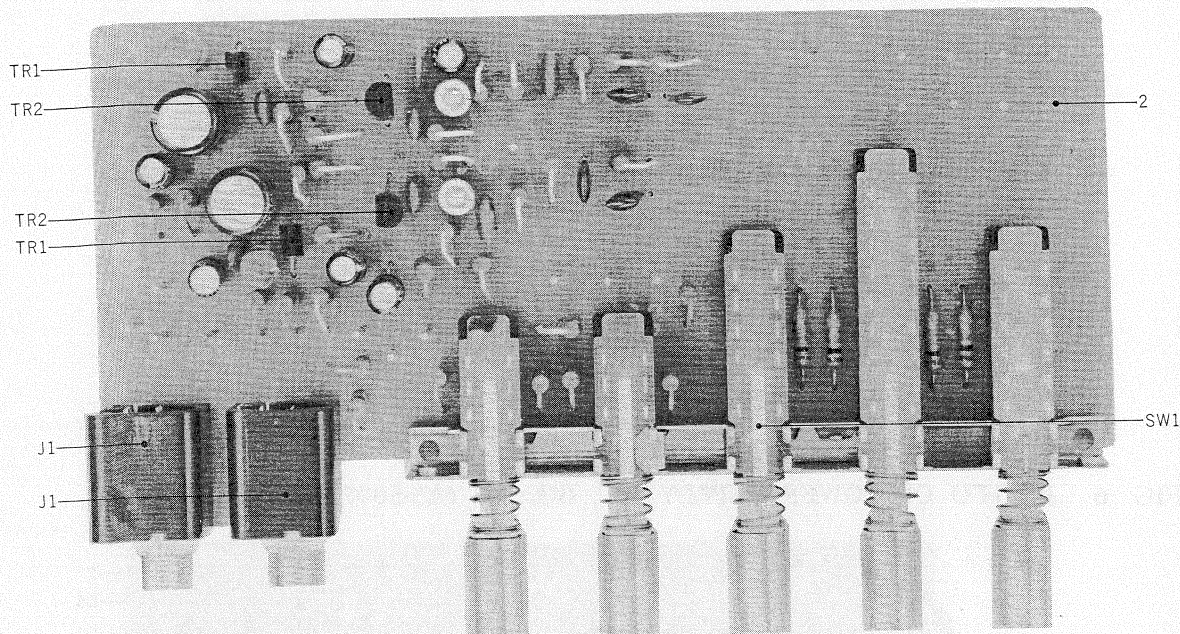

EQ. P.C. BOARD (A5-5083) BLOCK

Symbol No.	Parts No.	Description	Q'ty
4-1x	BA604258	EQ. P.C. Board Comp. (A5-5083) (DB)	1
4-TR1	ET517263	Transistor 2SC1312(G)(H)	2
4-TR2	ET604124	Transistor 2SC1313(G)(H)	2
4-SW1	ES628648	Push SW. 5FTM-0001FF-9920	1
4-J1	EJ391094	Mic. Jack 2PMJ1P	2
4-2	EJ539662	Wrapping Post 1x17	18
Capacitor, Vertical Type			
4-C1	EC220127	Elect. 100 μ F 16WV	2
4-C2	EC450055	Elect. 1 μ F 25WV	2
4-C3	EC556075	VFM 51PF(K) 50WV	2
4-C4	EC516767	Styrol 470PF(K) 50WV	2
4-C5	EC220432	Elect. 2.2 μ F 25WV	2
4-C6	EC556075	VFM 51PF(K) 50WV	2
4-C7	EC290531	VFM 100PF(K) 50WV	2
4-C8	EC379765	Mylar 0.0027 μ F(J) 50WV	2
4-C9	EC250841	Mylar 0.01 μ F(J) 50WV	2
4-C10	EC479621	Elect. 1 μ F 50WV NL	2
4-C11	EC450527	Elect. 4.7 μ F 25WV	2
Carbon Resistor Omitted			

FIG. 5 PHOTO OF POWER SUPPLY P.C. BOARD (A5-5026) BLOCK

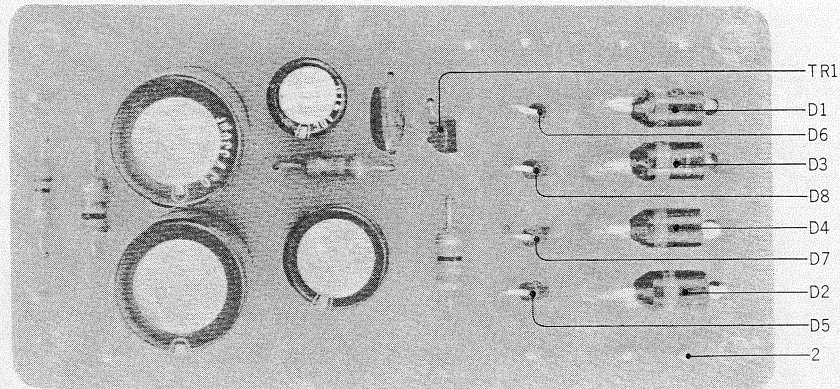
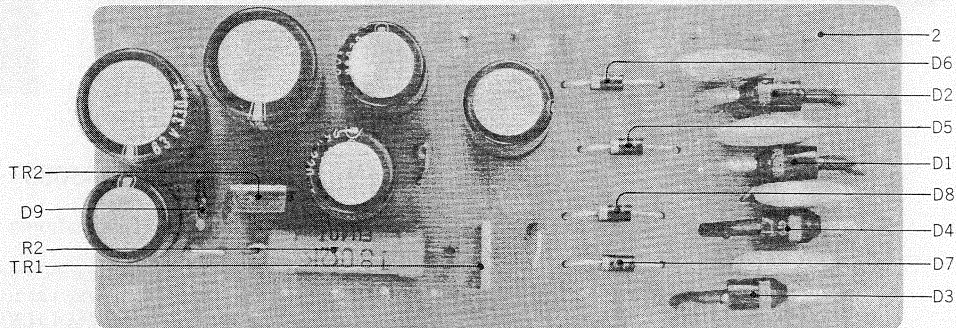

FIG. 6 PHOTO OF POWER SUPPLY P.C. BOARD (A5-5047) BLOCK



**POWER SUPPLY P.C. BOARD
(A5-5026) BLOCK**

Symbol No.	Parts No.	Description	Q'ty
5-1x	BA602763	Power Supply P.C. Board Comp. (A5-5026)	1
5-TR1	ET511920	Transistor 2SC1247(B)(V)	1
5-D 1to4	ED558033	Silicon Diode HIFI 400V 3A (Special)	4
5-D 5to8	ED511907	Silicon Diode 1N4002	4
5-2	EJ539662	Wrapping Post 1x17	10
Capacitor, Vertical Type			
5-C1	EC349604	Elect. 100 μ F 63WV	1
5-C2, 3	EC603112	Elect. 330 μ F 63WV	2
5-C4	EC346735	Elect. 47 μ F 50WV	1
5-C5	EC251291	Mylar 0.1 μ F(K) 50WV Carbon Resistor Omitted	1

**POWER SUPPLY P.C. BOARD
(A5-5047) BLOCK**

Symbol No.	Parts No.	Description	Q'ty
6-1x	BA604225	Power Supply P.C. Board Comp. (A5-5047) (DB)	1
6-TR1	ET452531	Transistor 2SD313(E)(F)	1
6-TR2	ET537300	Transistor 2SD361(D) (E)	1
6-D 1to4	ED558033	Silicon Diode HIFI 400V 3A(Special)	4
6-D 5to8	ED224526	Silicon Diode 10D1	4
6-D9	ED511918	Zener Diode WZ-240	1
6-2	EJ539662	Wrapping Post 1x17	16
6-R2	ER604078	Metal Oxide FILM/R. 3W 180 Ω (K)	1
Capacitor, Vertical Type			
6-C1to4	EC551160	Ceramic NB821 YZ 0.01 μ F(Z) 1.4WV	4
6-C5, 6	EC349604	Elect. 100 μ F 63WV	2
6-C7	EC321221	Elect. 100 μ F 50WV	1
6-C8, 9	EC603112	Elect. 330 μ F 63WV	2
6-C10	EC336115	Elect. 220 μ F 25WV Carbon Resistor Omitted	1

FIG. 7 PHOTO OF SW. P.C. BOARD (A5-5061) BLOCK

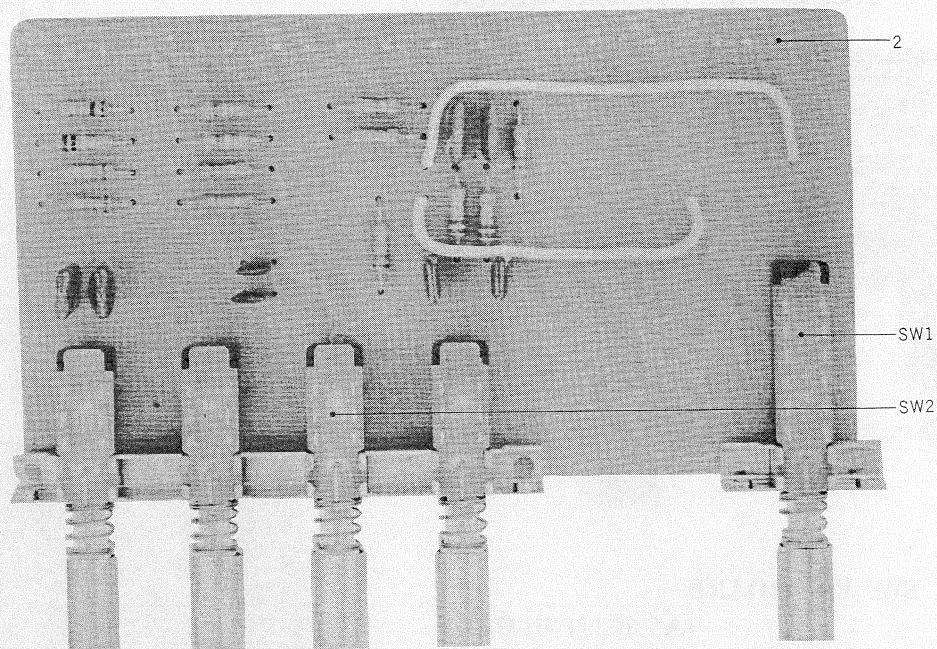
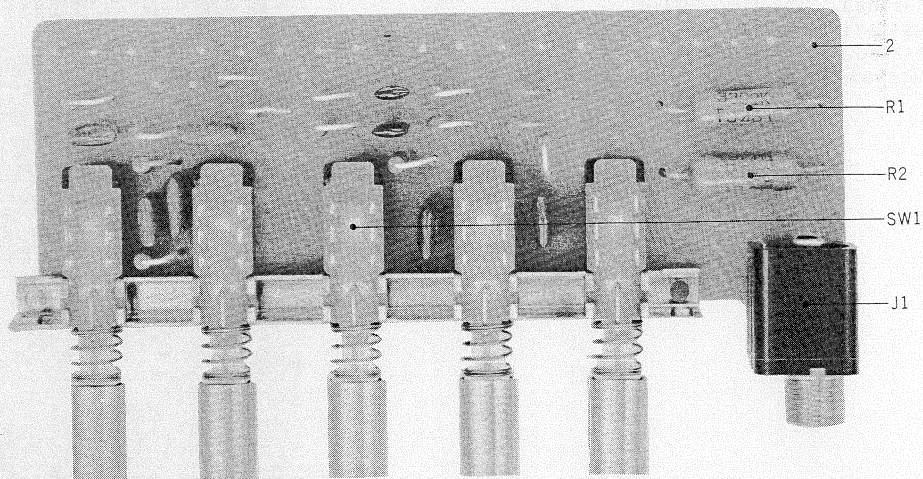

FIG. 8 PHOTO OF SW. P.C. BOARD (A5-5045) BLOCK



SW. P.C. BOARD (A5-5061) BLOCK

Symbol No.	Parts No.	Description	Q'ty
7-1x	BA602831	SW. P.C. Board Comp. (A5-5061)	1
7-SW1	ES562781	Push SW. 1FS-4U-8	1
7-SW2	ES628560	Push SW. 4FT-0007FF-1320	1
7-2	EJ539662	Wrapping Post 1x17	18
Capacitor, Vertical Type			
7-C1, 2	EC389237	VFM 200PF(J) 50WV	2
7-C3, 4	EC379192	Mylar 0.039μF(J) 50WV	2
7-C5, 6	EC308711	Mylar 0.047μF(K) 50WV	2
7-C7, 8	EC379833	Mylar 0.0082μF(K) 50WV	2
Carbon Resistor Omitted			

SW. P.C. BOARD (A5-5045) BLOCK

Symbol No.	Parts No.	Description	Q'ty
8-1x	BA604260	SW. P.C. Board Comp. (A5-5045) (DB)	1
8-SW1	ES628650	Push SW. 5FT-0004FF-2020	1
8-J1	EJ391083	Mic. Jack 3PMJ1P	1
8-2	EJ539662	Wrapping Post 1x17	18
8-R1, 2	ER517094	Metal Oxide Film/R. 2W 330Ω(K)	2
Capacitor, Vertical Type			
8-C1	EC389237	VFM 200PF(J) 50WV	1
8-C2, 3	EC379192	Mylar 0.039μF(J) 50WV	2
8-C4	EC389237	VFM 200PF(J) 50WV	1
8-C5, 6	EC379124	Mylar 0.047μF(J) 50WV	2
8-C7, 8	EC411827	Mylar 0.0082μF(J) 50WV	2
Carbon Resistor Omitted			

FIG. 9 PHOTO OF SPEAKER SW.
P.C. BOARD (A5-5027) BLOCK

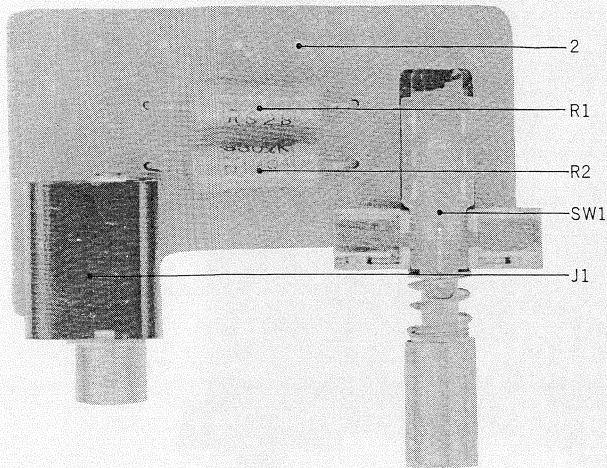

SPEAKER SW. P.C. BOARD
(A5-5027) BLOCK

Symbol No.	Parts No.	Description	Q'ty
9-1x	BA602820	Speaker SW. P.C. Board Comp. (A5-5027)	1
9-J1	EJ391083	Mic. Jack 3PMJ1P	1
9-SW1	ES551171	Push SW. 1FS-2U-12	1
9-2	EJ539662	Wrapping Post 1x17	4
9-R1, 2	ER559034	Metal Oxide Film/R. 2W 330Ω(K)	2

FIG. 10 PHOTO OF DOLBY P.C. BOARD
(A5-5046) BLOCK

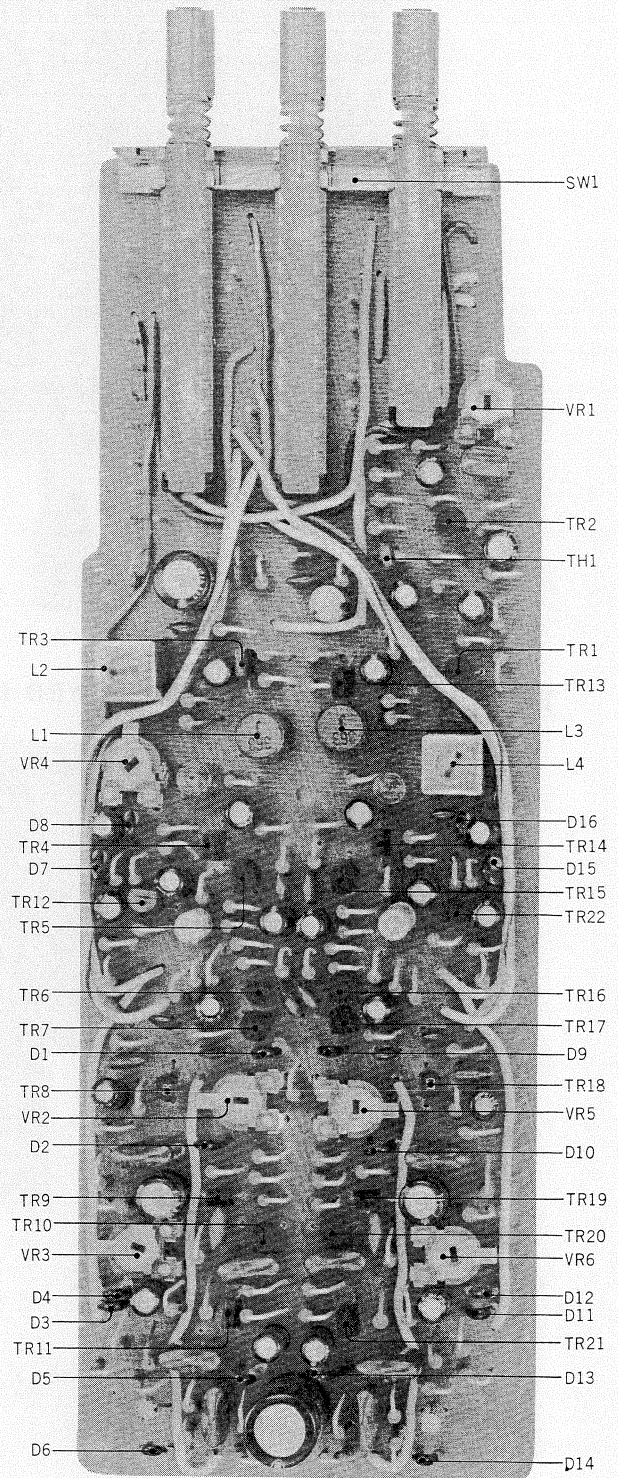

DOLBY P.C. BOARD (A5-5046) BLOCK

Symbol No.	Parts No.	Description	Q'ty	Symbol No.	Parts No.	Description	Q'ty
10-1x	BA 604247	Dolby P.C. Board Comp. (A5-5046)	1	10-C26	EC251291	Mylar 0.1 μ F(K) 50WV	1
10-TR1, 2	ET 520841	Transistor 2SC711(E)(F)(G)	2	10-C27	EC320040	Elect. 47 μ F 16WV	1
10-TR3, 4	ET 517263	Transistor 2SC1312(G) (H)	2	10-C28	EC290531	VFM 100PF(K) 50WV	1
10-TR5	ET 557976	Transistor 2SA628(E)(F)	1	10-C29	EC320051	Elect. 10 μ F 16WV	1
10-TR6	ET 517263	Transistor 2SC1312(G)(H)	1	10-C30	EC251291	Mylar 0.1 μ F(K) 50WV	1
10-TR7	ET 520841	Transistor 2SC711(E)(F) (G)	1	10-C31	EC320051	Elect. 10 μ F 16WV	1
10-TR8	ET 491051	FET 2SK30A(GR)	1	10-C32, 33	EC251291	Mylar 0.1 μ F(K) 50WV	2
10-TR9	ET 517263	Transistor 2SC1312(G)(H)	1	10-C34	EC604440	Solid Aluminum 0.33 μ F(M) 25WV	1
10-TR10	ET 557976	Transistor 2SA628(E)(F)	1	10-C35to37	EC320051	Elect. 10 μ F 16WV	3
10-TR11,12	ET 520841	Transistor 2SC711(E)(F)(G)	2	10-C38	EC357232	Mylar 0.0039 μ F(K) 50WV	1
10-TR13,14	ET 517263	Transistor 2SC1312(G)(H)	2	10-C39	EC495865	Styrol 3000PF(J) 50WV	1
10-TR15	ET 557976	Transistor 2SA628(E)(F)	1	10-C40	EC250716	Mylar 0.0022 μ F(K) 50WV	1
10-TR16	ET 517263	Transistor 2SC1312(G)(H)	1	10-C41	EC450055	Elect. 1 μ F 25WV	1
10-TR17	ET 520841	Transistor 2SC711(E)(F)(G)	1	10-C42	EC357827	VFM 50PF(K) 50WV	1
10-TR18	ET 491051	FET 2SK30A(GR)	1	10-C43	EC320051	Elect. 10 μ F 16WV	1
10-TR19	ET 517263	Transistor 2SC1312(G)(H)	1	10-C44	EC432810	Elect. 10 μ F 16WV NL	1
10-TR20	ET 557976	Transistor 2SA628(E) (F)	1	10-C45	EC320051	Elect. 10 μ F 16WV	1
10-TR21,22	ET 520841	Transistor 2SC711(E)(F)(G)	2	10-C46	EC556525	FM 22PF(K) 500WV	1
10-D1	ED219464	Germanium Diode 1N34A	1	10-C47	EC320051	Elect. 10 μ F 16WV	1
10-D2	ED491130	Zener Diode WZ-085	1	10-C48	EC362125	Mylar 0.0056 μ F(K) 50WV	1
10-D3, 4	ED 560913	Silicon Diode 1S2473 VE	2	10-C49	EC251122	Mylar 0.027 μ F(K) 50WV	1
10-D5	ED219464	Germanium Diode 1N34A	1	10-C50	EC362158	Mylar 0.0047 μ F(K) 50WV	1
10-D6	ED 560913	Silicon Diode 1S2473 VE	1	10-C51	EC320051	Elect. 10 μ F 16WV	1
10-D7,8,9	ED219464	Germanium Diode 1N34A	3	10-C52	EC251291	Mylar 0.1 μ F(K) 50WV	1
10-D10	ED491130	Zener Diode W Z-085	1	10-C53	EC320040	Elect. 47 μ F 16WV	1
10-D11,12	ED 560913	Silicon Diode 1S2473 VE	2	10-C54	EC290531	VFM 100PF(K) 50WV	1
10-D13	ED219464	Germanium Diode 1N34A	1	10-C55	EC320051	Elect. 10 μ F 16WV	1
10-D14	ED 560913	Silicon Diode 1S2473 VE	1	10-C56	EC251291	Mylar 0.1 μ F(K) 50WV	1
10-D15, 16	ED219464	Germanium Diode 1N34A	2	10-C57	EC320051	Elect. 10 μ F 16WV	1
10-VR1	EV 560136	Semi-Fixed/Vol. V10K8-4-2 20k Ω	1	10-C58,59	EC251291	Mylar 0.1 μ F(K) 50WV	2
10-VR2	EV 499364	Semi-Fixed/Vol. V10K8-4-2 5k Ω	1	10-C60	EC604440	Solid Aluminum 0.33 μ F(M) 25WV	1
10-VR3	EV 484863	Semi-Fixed/Vol. V10K8-4-2 1k Ω (Metalized Film)	1	10-C61,62	EC320051	Elect. 10 μ F 16WV Carbon Resistor Omitted	2
10-VR4	EV 560136	Semi-Fixed/Vol. V10K8-4-2 20k Ω	1				
10-VR5	EV 499364	Semi-Fixed/Vol. V10K8-4-2 5k Ω	1				
10-VR6	EV 484863	Semi-Fixed/Vol. V10K8-4-2 1k Ω (Metalized Film)	1				
10-L1	EO 496350	Inductor 146LY 36MH(J)	1				
10-L2	EO 496361	Inductor 6070GE 23MH(J)	1				
10-L3	EO 496350	Inductor 146Y 36MH(J)	1				
10-L4	EO 496361	Inductor 6070GE 23MH(J)	1				
10-SW1	ES 628637	Push SW. 3FT-0008FF-2020	1				
10-TH1	ED 485370	Thermister 24D26	1				
10-2	EJ 539662	Wrapping Post 1x17	20				
		Capacitor, Vertical Type					
10-C1	EC 250841	Mylar 0.01 μ F(J) 50WV	1				
10-C2	EC 379157	Mylar 0.03 μ F(J) 50WV	1				
10-C3	EC 220994	Elect. 10 μ F 25WV	1				
10-C4, 5	EC 320051	Elect. 10 μ F 16WV	2				
10-C6	EC 331828	Elect. 3.3 μ F 25WV	1				
10-C7	EC 331705	Elect. 22 μ F 16WV	1				
10-C8	EC 302253	Mylar 0.15 μ F(K) 50WV	1				
10-C9	EC 320051	Elect. 10 μ F 16WV	1				
10-C10	EC 357232	Mylar 0.0039 μ F(K) 50WV	1				
10-C11	EC 495865	Styrol 3000PF(J) 50WV	1				
10-C12	EC 250716	Mylar 0.0022 μ F(K) 50WV	1				
10-C13	EC 450055	Elect. 1 μ F 25WV	1				
10-C14	EC 357827	VFM 50PF(K) 50WV	1				
10-C15	EC 320051	Elect. 10 μ F 16WV	1				
10-C16	EC 432810	Elect. 10 μ F 16WV NL	1				
10-C17	EC 320051	Elect. 10 μ F 16WV	1				
10-C18	EC 556525	FM 22PF(K) 500WV	1				
10-C19	EC 320051	Elect. 10 μ F 16WV	1				
10-C20	EC 336126	Elect. 47 μ F 25WV	1				
10-C21	EC 336115	Elect. 220 μ F 25WV	1				
10-C22	EC 362125	Mylar 0.0056 μ F(K) 50WV	1				
10-C23	EC 251122	Mylar 0.027 μ F(K) 50WV	1				
10-C24	EC 362158	Mylar 0.0047 μ F(K) 50WV	1				
10-C25	EC 320051	Elect. 10 μ F 16WV	1				

When ordering parts, please describe Parts Number, Serial Number, and Model Number in detail.

Dolby is a trademark of Dolby Laboratories, Inc. Under License from Dolby Laboratories, Inc.

FIG. 11 PHOTO OF ASSEMBLY BLOCK

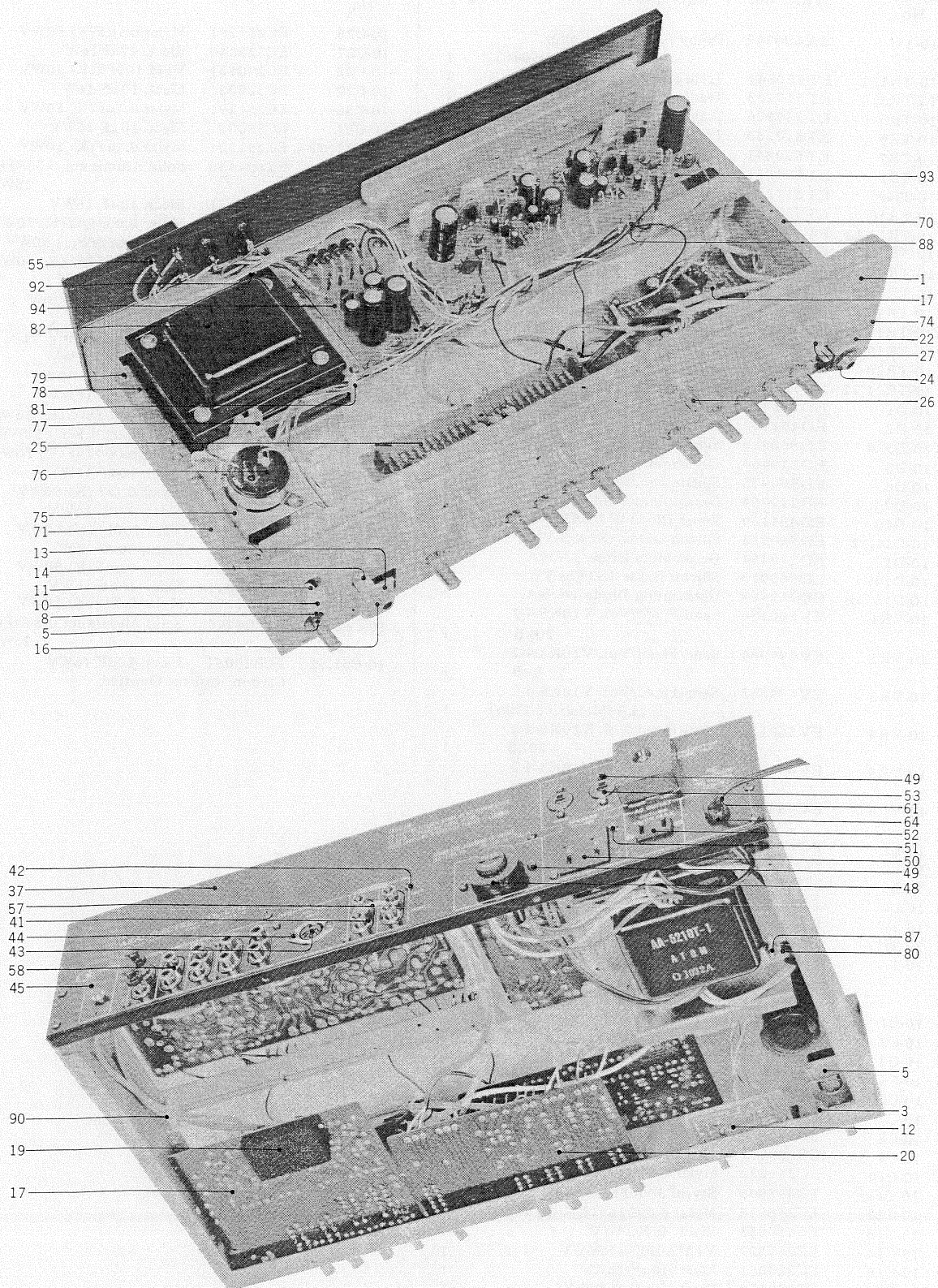

ASSEMBLY BLOCK

Ref. No.	Parts No.	Description	Schematic No.	Q'ty
FRONT CHASSIS BLOCK				
11-1	TA605970	Front Chassis	A5-5008	1
11-2x	TA604236	Front Chassis B(DB)	A5-5034	1
11-3	TA609761	SW. Angle	A5-5009	1
11-4x	TA609761	SW. Angle (EC)	A5-5009	1
11-5	ES469541	Push SW. TV-3 JB52	25-5-60	1
11-6x	ES602594	Push SW. 250V 4A(EC)	25-5-147	1
11-7x	EC551160	Ceramic/C. NB821 YZ 0.01μF(Z) 1.4KWV	24-5-55	1
11-8	ZS422076	Screw, Pan Head 3x5		2
11-9x	TA606576	Power Insulator Paper (CSA,EC)	A5-5074	1
11-10	EL458864	Pilot Lamp (L/T) 8V 80MA(150M/Mx2)	28-2-22	1
11-11	TA510502	Lamp Holder	T5-5035	1
11-12	BA602820	Speaker SW. P.C. Board Comp. AA-5210	A5-5027	1
11-13	TA609772	Jack MT. Table A	A5-5010	1
11-14	ZS325495	Tapping Screw #2 3x6		2
11-15x	ZW434597	Washer (ALP) D9.3x14.2x0.7T		1
11-16	ZW554624	E Jack Nut	7-1-56	2
11-17	BA602818	EQ. SW. P.C. Board Comp. AA-5210	A5-5028	1
11-18x	BA604258	EQ. P.C. Board Comp. AA-5210DB	A5-5083	1
11-19	EZ478675	Upper Cover Cushion	55-5053	1
11-20	BA602831	SW. P.C. Board Comp. AA-5210	A5-5061	1
11-21x	BA604260	SW. P.C. Board Comp. AA-5210DB	A5-5045	1
11-22	TA609783	Jack MT. Table B	A5-5011	1
11-23x	EZ225180	Nylon Collar, Jack	LD-520	1
11-24x	ZW260368	Washer (Fiber) D9.2x18x0.5T		1
11-25	BA602807	Tone Control P.C. Board Comp. AA-5210	A5-5029	1
11-26	EV602414	Co-axial 2-throw Vol. (W/Preset) V24L5DGM 2BM250K x 2	36-29-4	1
11-27	EV602425	Co-axial 2-throw Vol. V24L5GWTN 1Z500Kx2	36-1-33	1
11-28x	TA610031	Jack Retaining Base C (DB)	A5-5035	1
11-29x	BA604247	Dolby P.C. Board Comp. AA-5210DB	A5-5046	1
11-30x	TA610007	Spring, Meter Retainer	A5-5036	1
11-31x	EM604091	Meter	46-1-95	2
11-32x	TA610018	Lamp Case	A5-5037	1
11-33x	EL539684	Lamp, Fuse Type 8V 0.3A	28-2-27	1
11-34x	EJ367986	Fuse Holder 1P AC125V 5A	40-1-8	1
11-35x	EV604080	2-axial 2-throw/Vol. V24L5DWTN 15A 250Kx2	36-3-57	2
11-36x	TA610042	Vol. Retaining Plate	A5-5052	1
REAR PANEL BLOCK				
11-37	SP605981	Rear Panel A	A5-5012	1
11-38x	SP605992	Rear Panel B (CSA)	A5-5012	1
11-39x	SP606003	Rear Panel C (EC)	A5-5012	1
11-40x	TA610154	Rear Panel 1 (DB)	A5-5038	1
11-41	EJ539763	4P Wrapping pin Jack B T5346-B	31-1-106	2
11-42	ZS570385	ISO Screw, Pan Head 3x8		4
11-43	EJ299316	Jack, 5P Din S-1 8123	31-1-24	1
11-44	ZS447761	Tapping Screw #2 3x6 (BR) (Black)		2
11-45	EZ486257	Metal Terminal T-10	32-1-27	1
11-46x	ZW273802	Toothed Lock Washer M3		1
11-47x	EC551160	Ceramic/C. NB821 YZ 0.01μF(Z) 1.4KWV	24-4-55	1
11-48	EJ233370	Socket (Volt. Selector) S-18010	40-2-3	1
11-49	ZS421740	Screw, Pan Head 3x8		6

Ref. No.	Parts No.	Description	Schematic No.	Q'ty
11-50	EJ551316	Speaker Consent Assy. P0409	31-1-98	1
11-51	ZS570385	ISO Screw, Pan Head 3x8		2
11-52	EJ378944	Socket, AC U/L S-1 9122	31-1-47	1
11-53	EJ602537	Connector Socket 2P	31-1-116	2
11-54x	ZW516993	Nut M3		4
11-55	EJ539796	2P Fuse Holder	40-1-29	1
11-56x	ZS463353	Tapping Screw #2 3x8(BR)		2
11-57	EJ554578	Short Plug	42-1-66	2
11-58	EJ551340	6P Wrapping Pin Jack B T-5347(B)	31-1-102	1
11-59x	ER452777	Carbon/R. (Insu. Type) RD1/4 160K(J)	35-9-5	2
11-60x	ER364994	Carbon/R. (Insu. Type) RD1/4 39K(J)	35-9-5	2
11-61	EW374894	U/L AC Cord 3M	26-3-19	1
11-62x	EW559260	Power Cord (EC) TYPE-412	26-3-33	1
11-63x	EW315448	Australia Cord (3 Core)	26-3-11	1
11-64x	EZ382263	Strain Relief SR-4K-4	2-7-12	1
11-65x	EZ246936	Strain Relief SR-6W-1 (WG. 3 Core)	2-7-8	1
11-66x	EF563703	Fuse 2A 250V	39-1-50	1
11-67x	ZW273881	Earth Lug M4 (3 Core)		1
11-68x	ZW413188	Nut M4 (3 Core)		1
11-69x	ZW273914	Spring Washer M4(3 Core)		1
ASSEMBLY BLOCK				
11-70	TA605924	Side Plate Metal Parts A (Right)	A5-5002	1
11-71	TA606058	Side Plate Metal Parts B (Left)	A5-5002	1
11-72x	TA610446	Side Plate Metal Fitting D (Right) (DB)	A5-5031	1
11-73x	TA610132	Side Plate Metal Fitting C (Left) (DB)	A5-5031	1
11-74	ZS325495	Tapping Screw #2 3x6		20
11-75	EZ594325	Condenser Retaining Plate	A5-5004	1
11-76	EC602368	Elect./C. (Lug Type) 2200μF 63WV	24-10-93	1
11-77	EJ254957	Lug Plate KP1L	33-3-2	1
11-78	TA605935	Trans. MT. Table	A5-5003	1
11-79	ZS447840	Tapping Screw #2 3x8(BR)		4
11-80	EZ621900	Cord Holder 4772	2-7-47	1
11-81	MZ229138	Wire Bundle Holder N-108	2-35-1	1
11-82	BT602370	Power Trans. AA-5210T-1	38-4-300	1
11-83x	BT602638	Power Trans. AA-5210T-2	38-4-299	1
11-84x	BT602548	Power Trans. AA-5210T-3	38-4-298	1
11-85x	BT604067	Power Trans. AA-5210DBT-1	38-4-303	1
11-86x	ZW273914	Spring Washer M4		4
11-87	ZW273960	Nut M4		4
11-88	EJ551035	4P Wrapping Terminal T-5251	32-1-36	2
11-89x	EJ539447	2P Earth Terminal T4460	32-1-32	1
11-90	EJ496686	Wire Clip 220-JD486010-110	2-7-16	4
11-91x	EJ551057	Wire Clip 220-JD481010-0021(DB)	2-7-27	4
11-92	TA605878	Lead Protector	A5-5007	1
11-93	BA602752	Main Amp. P.C. Board Comp. AA-5210	96-5008	1
11-94	EA602763	Power Supply P.C. Board Comp. (DB)	A5-5026	1
11-95x	BA604225	Power Supply P.C. Board Comp.	A5-5047	1
11-96x	EZ629820	Main Amp. Cushion	A5-5090	1
11-97x	EA606914	Fuse P.C. Board (EC,CSA)	A5-5062	1
11-98x	EJ592503	Fuse Clip, P.C. Board H0426 (EC, CSA)	40-1-37	10
11-99x	EJ539662	Wrapping Post 1x17 (EC, CSA)	32-1-48	10
11-100x	EZ605913	Fuse Angle A5 (EC,CSA)	A5-5064	2
11-101x	EZ605902	Terminal Mt. Table (EC, CSA)	A5-5063	1
11-102x	EZ546625	Connector Insulator Paper (EC, CSA)	ND-1081	1
11-103x	EJ561227	Terminal No. 500/2 (EC, CSA)	52-1-19	1

When ordering parts, please describe Parts Number, Serial Number, and Model Number in detail.

FIG. 12 PHOTO OF FINAL ASSEMBLY BLOCK

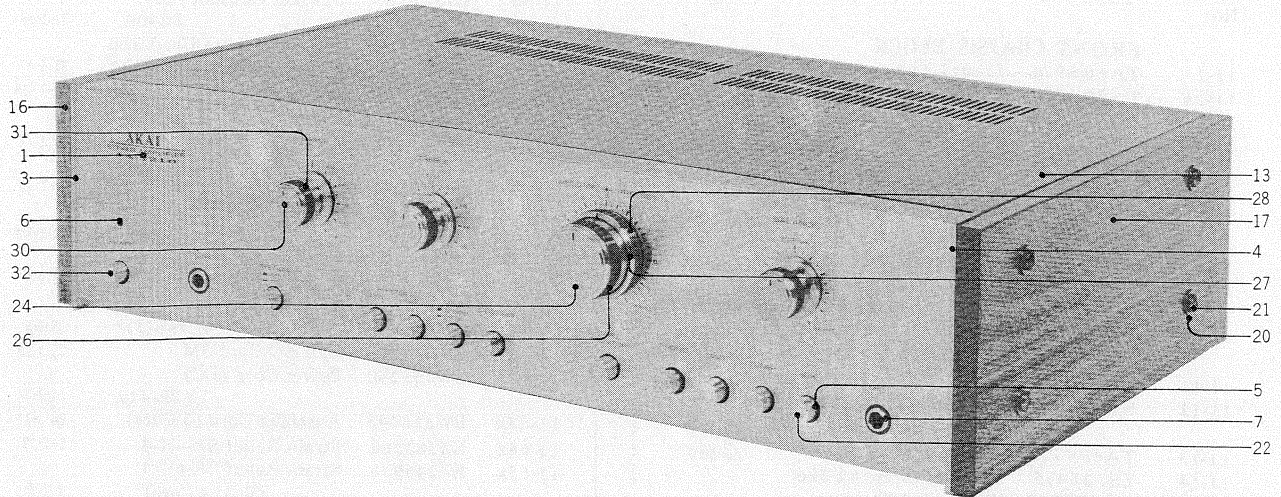

FINAL ASSEMBLY BLOCK

Ref. No.	Parts No.	Description	Schematic No.	Q'ty	Ref. No.	Parts No.	Description	Schematic No.	Q'ty
FRONT PANEL BLOCK									
12-1	SP606014	Front Panel	A5-5014	1	12-39x	TA539537	2P Fuse Holder Cover	2-34-78	1
12-2x	TA610200	Front Panel B (DB)	A5-5041	1	12-40x	EF601986	Fuse 1.5A 125V (CSA)	39-1-52	2
12-3	TA609794	Side Fitting Left	A5-5017	1	12-41x	EF623092	Fuse (SEMKO) 1.25A(EC)	39-1-54	2
12-4	TA609816	Side Fitting Right	A5-5017	1	12-42x	EF562746	Fuse 3A 125V (CSA)	39-1-47	1
12-5	TA545905	Push Button Bush	98-5061	11	12-43x	EF623103	Fuse (SEMKO T Type) 1AT (EC)	39-1-53	1
12-6	SZ457975	Lamp Lens B	55-5012	1	12-44x	EF602627	Fuse 0.3A 125V (CSA)	39-1-52	1
ASSEMBLY BLOCK									
12-7	ZW526577	Collar B, Jack	MC-5006	2	12-45x	EF623114	Fuse (SEMKO T Type) 200MAT (EC)	39-1-53	1
12-8x	SP606025	Bottom Plate	A5-5018	1	12-46x	EF588420	Fuse 1A 125V	39-1-52	1
12-9x	TA610187	Bottom Plate B (DB)	A5-5040	1	12-47x	EF623125	Fuse (SEMKO T Type) 2.5AT (EC)	39-1-53	1
12-10x	ZS447840	Tapping Screw #2 3x8(BR)		8	12-48x	EF563703	Fuse 2A 250V	39-1-50	1
12-11x	SA609952	Tran Leg D	2-6-11	4	12-49x	EJ552778	Short Pin Plug ASB-2	42-1-65	2
12-12x	ZW565942	Tapping Screw #2 4x8 Pan Head		4	12-50x	EJ550912	Speaker Plug ASP-1	42-1-64	2
12-13	SP606036	Upper Plate	A5-5019	1	12-51x	EJ602346	Speaker Plug CP045-1-1	42-1-75	2
12-14x	TA610108	Upper Plate B (DB)	A5-5043	1					
12-15x	ZS447761	Tapping Screw #2 3x6 (BR) (Black)		2					
12-16	SP605946	Side Plate A (Left)	A5-5020	1					
12-17	SP606047	Side Plate B (Right)	A5-5020	1					
12-18x	SP610143	Side Plate D (Left) (DB)	A5-5059	1					
12-19x	SP610435	Side Plate C (Right) (DB)	A5-5059	1					
12-20	ZW602381	Washer D4.2x11x1t		8					
12-21	ZW552824	ISO Screw, Binding Head 4x18		8					
12-22	SK531224	Push Button Knob	91-5051	10					
12-23x	SB628108	Push Button F (Green) (DB)	91-5051	1					
12-24	SK609838	Volume Knob	A5-5049	1					
12-25x	ZS444240	Set Screw, Hexagon Socket 4x8 (CUP/P.)		1					
12-26	MB609851	Knob Rubber Ring C	A5-5054	1					
12-27	SK631192	Memory Knob Ring	A5-5048	1					
12-28	MB605880	Knob Rubber Ring D	A5-5055	1					
12-29x	ZW493312	Washer D6.2x10x1t		1					
12-30	SK627535	Single Knob B-2	A5-5053	3					
12-31	MB551103	Double Knob Lower Rubber Ring	3-10-5	3					
12-32	SK627524	Push Button Knob G	91-5051	1					
12-33x	SK628110	Double Knob 2 (DB)	A5-5087	2					
12-34x	MB610097	Knob Rubber Ring	A5-5419	2					
12-35x	SK628121	Double Knob 1	A5-5086	2					
12-36x	MB610086	Knob Rubber Ring	A5-5051	2					
12-37x	EF563681	Fuse 1A 250V	39-1-50	1					
12-38x	EF563692	Fuse 1.5A 250V	39-1-50	2					

When ordering parts, please describe Parts Number, Serial Number, and Model Number in detail.

SECTION 3

SCHEMATIC DIAGRAM

1. AA-5210 SCHEMATIC DIAGRAM
2. AA-5210 DB SCHMATIC DIAGRAM
3. AA-5210 DB (DOLBY) SCHMATIC DIAGRAM

AA-5210

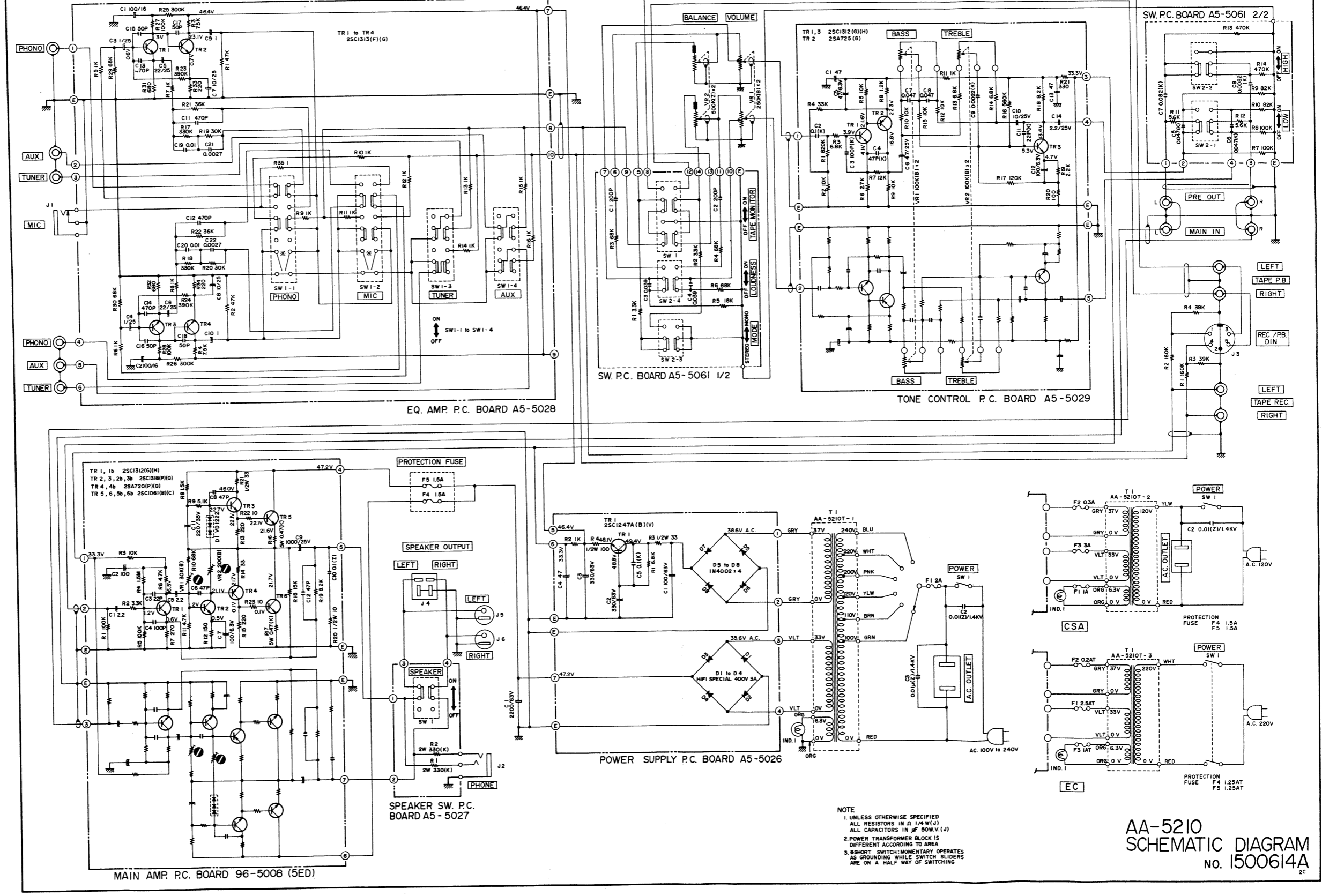

NOTE
 1. UNLESS OTHERWISE SPECIFIED
 ALL RESISTORS IN Ω, 1/4 W.(J)
 ALL CAPACITORS IN μF 50W.V.(J)
 2. POWER TRANSFORMER BLOCK IS
 DIFFERENT ACCORDING TO AREA
 3. SHORT SWITCH; MOMENTARY OPERATES
 AS GROUNDING WHILE SWITCH SLIDERS
 ARE ON A HALF WAY OF SWITCHING

AA-5210
 SCHEMATIC DIAGRAM
 NO. 1500614A
 2C

AA-5210DB

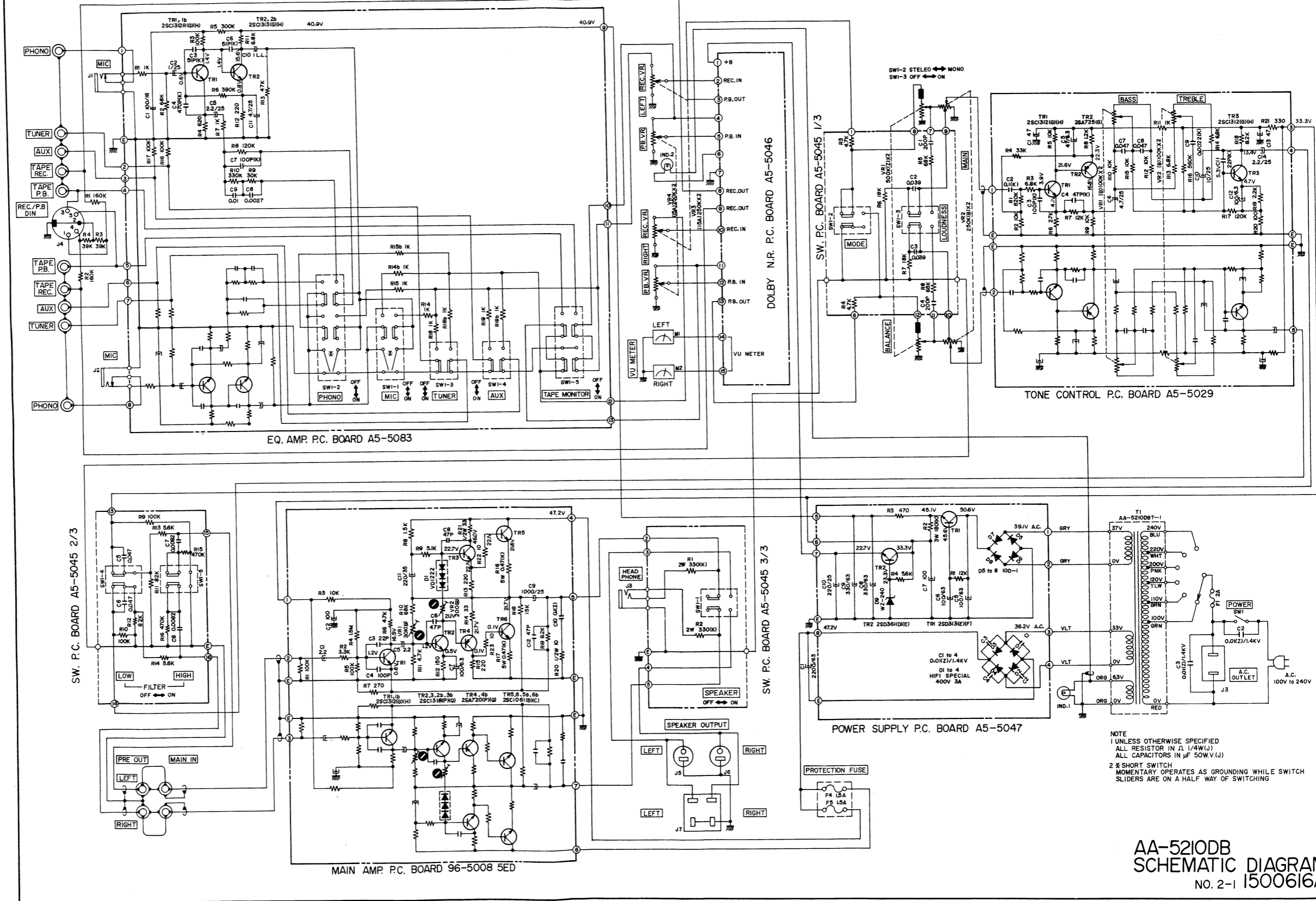

NOTE
 1 UNLESS OTHERWISE SPECIFIED
 ALL RESISTOR IN Ω 1/4W(J)
 ALL CAPACITORS IN μ F 50W.V.(J)
 2 \times SHORT SWITCH
 MOMENTARY OPERATES AS GROUNDING WHILE SWITCH
 SLIDERS ARE ON A HALF WAY OF SWITCHING

AA-5210DB
 SCHEMATIC DIAGRAM
 NO. 2-1 1500616A
 2c

AA-5210DB

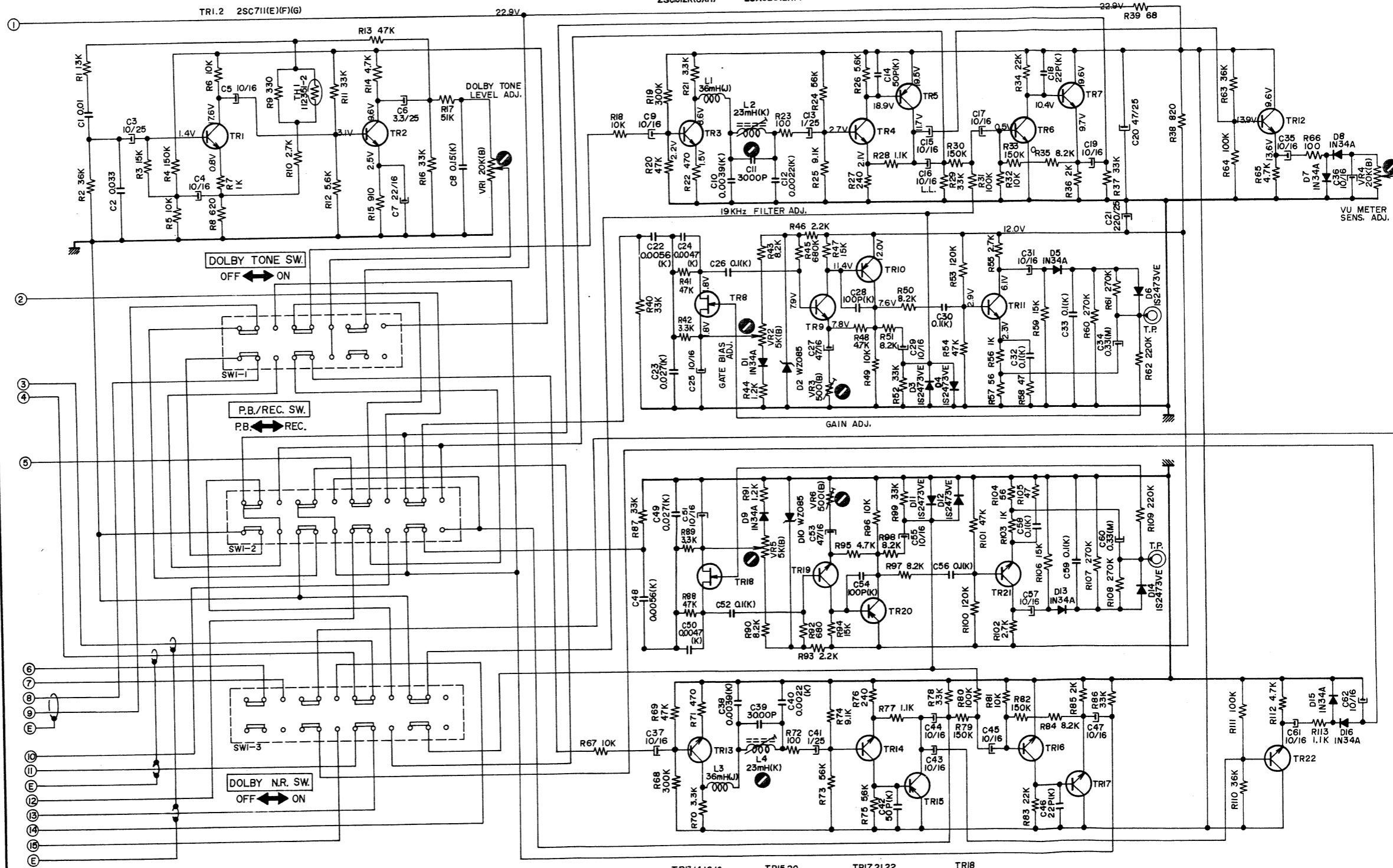

TR3,4,6,9 2SC312R(G)(H) TR5,10 2SA628(E)(F) TR8 2SK30A(GR) TR7,11,12 2SC711(E)(F)(G)

TR13,14,16,18 2SC312R(G)(H) TR15,20 2SA628(E)(F) TR17,21,22 2SC711(E)(F)(G) TR18 2SK30A(GR)

DOLBY N.R. P.C. BOARD A5-5046

AA-5210DB (DOLBY)
SCHEMATIC DIAGRAM
NO.2-2 1500617A
2C