

# Accuphase

FM STEREO TUNER T-101

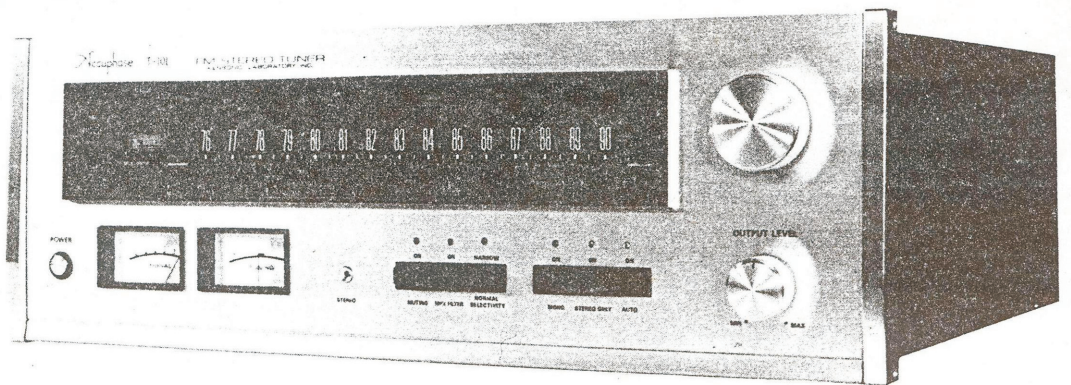

## Service Information

STARTING WITH SERIAL NO. D4Y001

# EXTERNAL VIEW

## FRONT

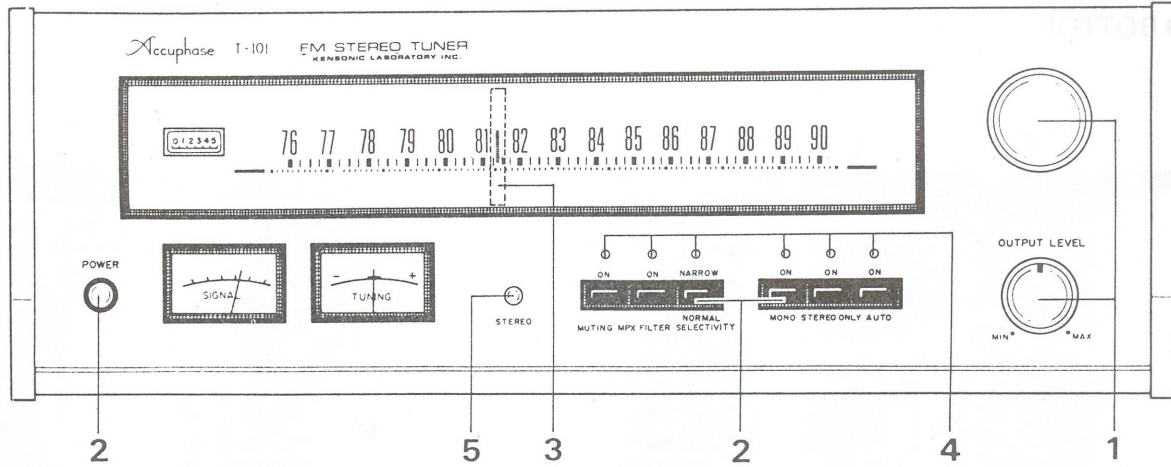

## REAR

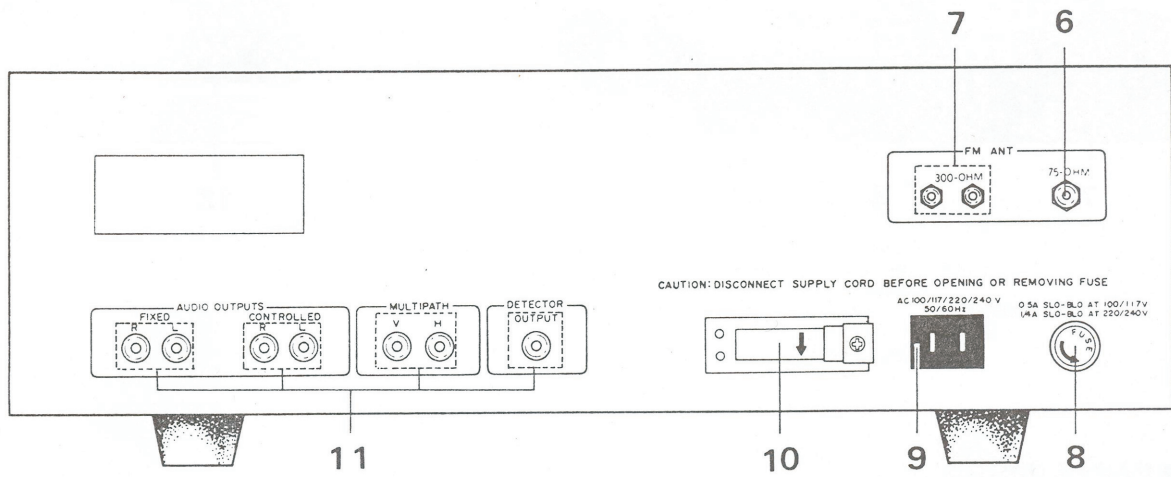

## PARTS LIST

No.	Description	Part No.	Remarks
1	Knob for TUNING OUTPUT LEVEL	381-4004-04 381-2603-00	Ref. INTERNAL VIEW ⑤⑬
2	Push-button for Power Switch Push-button Assembly	389-1202-04 389-5001-14	Ref. INTERNAL VIEW ⑪⑫
3	Dial Pointer Assembly	206-0001-10	
4	Position Indicator	173-0901-14	Ref. EXPLODED VIEW ①
5	Stereo Indicator	173-1201-14	(Indicator Assembly)
6	Coaxial Cable Receptacle	302-7001-00	

No.	Description	Part No.	Remarks
7	Balun Transformer Assembly Belun Transformer	708-0001-00 509-0001-00	
8	Fuse Holder Fuse At 100, 117V Fuse At 220, 240V	306-0201-00 310-1051-00 310-1141-00	for UL, CSA. 0.5A SLO-BLO 1/4A SLO-BLO
9	AC Connector Plug	301-3201-00	
10	Voltage Selector Jack Voltage Selector Plug Voltage Selector Fixed Bracket	302-4001-00 301-4001-00 248-0001-14	
11	Pin Jack Pin Jack	302-0101-00 302-0201-00	1-pin 2-pin

# TABLE OF CONTENTS

EXTERNAL VIEW .....	1
INTERNAL VIEW .....	2
EXPLODED VIEW .....	3
MISCELLANEOUS .....	4
HOW TO REPLACE THE FOLLOWING PARTS .....	4
FM FRONT-END ASSEMBLY .....	5
FM IF AMP ASSEMBLY .....	6
MPX AUDIO ASSEMBLY .....	7
POWER SUPPLY ASSEMBLY .....	8
PUSH-BUTTON SWITCH ASSEMBLY .....	8
BALUN TRANSFORMER ASSEMBLY .....	8
HOW TO RE-STRING THE DIAL MECHANISM .....	9
TRANSISTOR LEADS .....	9
CIRCUIT DESCRIPTION .....	10
SCHEMATIC DIAGRAM .....	11
FM/MPX ALIGNMENT .....	13
SPECIFICATIONS .....	15

## BLOCK DIAGRAM

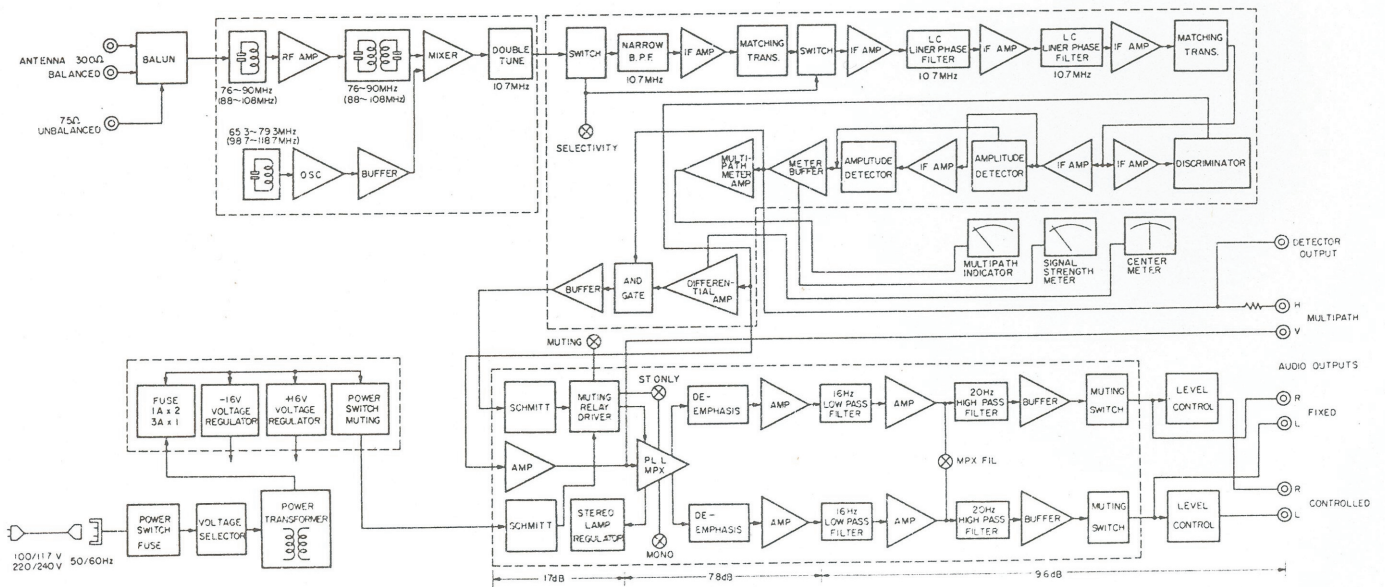

# INTERNAL VIEW

## ● BOTTOM SIDE

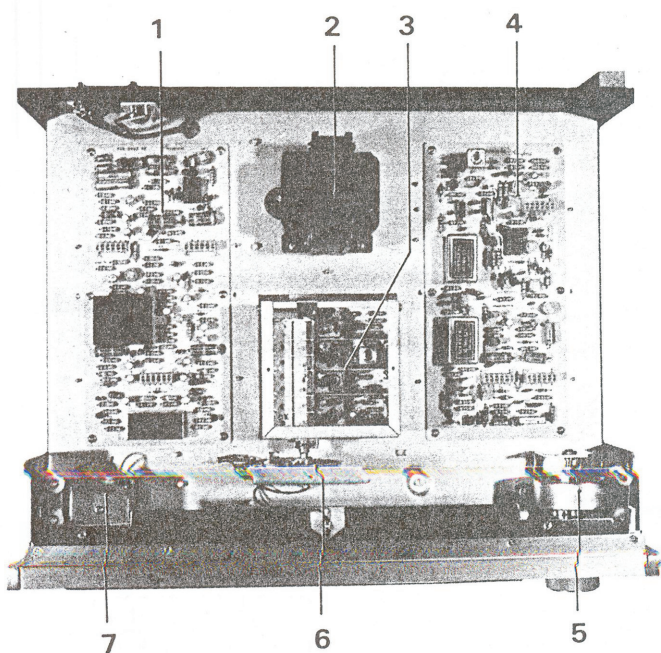

## ● TOP SIDE

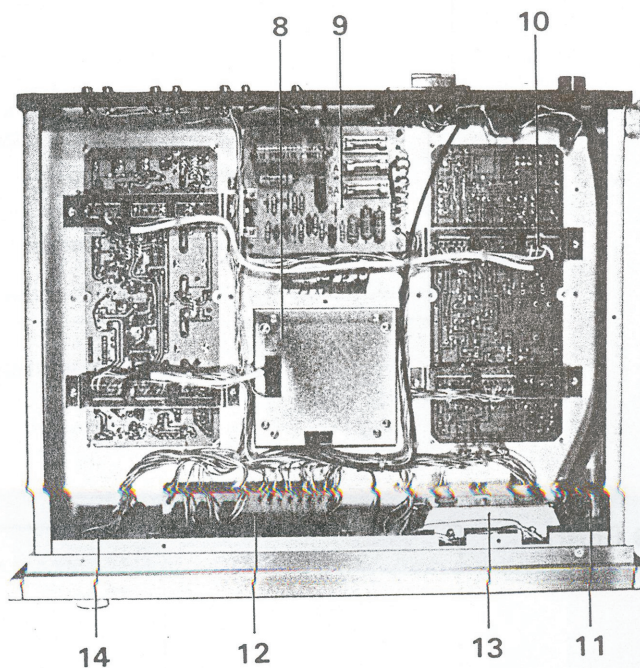

## ● PARTS LIST

No.	Description	Part No.	Remarks
1	MPX & Audio Assembly	706-0002-00	
2	Power Transformer	510-0002-00	
3	FM, Front-end	700-0001-02	
4	FM IF AMP Assembly	703-0002-00	
5	Tuning Shaft Assembly	203-0001-23	included Flywheel.(Old type)
	Tuning Shaft Assembly	203-0002-05	(New type: with out Holder)
	Tuning Shaft Holder	247-0061-04	
6	Plate	230-0014-04	
7	Meter Lamp Fixed Bracket	247-0038-14	for MULTIPATH Ref. EXPLODED VIEW⑦
8	Front-end Shield Plate	230-0013-03	
9	Power Supply Assembly	719-0006-00	
	Fuse	310-0101-00	1 A
	Fuse	310-0301-00	3 A

No.	Description	Part No.	Remarks
10	Connector Plug Fixed Bracket	247-0035-04	
	Connector Plug	304-0601-00	
11	Push Switch for Power	354-1003-00	
	Push-button	389-1202-04	
12	Push-button Switch Assembly	716-0011-00	
	Push Switch	354-6401-00	
	Push Switch Fixed Bracket	247-0020-03	
	Pilot Lamp (8V/150mA)	176-4401-00	Ref. EXPLODED VIEW⑨
	Lamp Fixed Bracket	247-0023-03	
	Push-button	389-5001-04	
13	T & S Meter Fixed Bracket	247-0034-03	Ref. EXPLODED VIEW⑦
14	Variable Resistor for OUTPUT LEVEL	573-2102-00	10kΩ×2

# EXPLODED VIEW

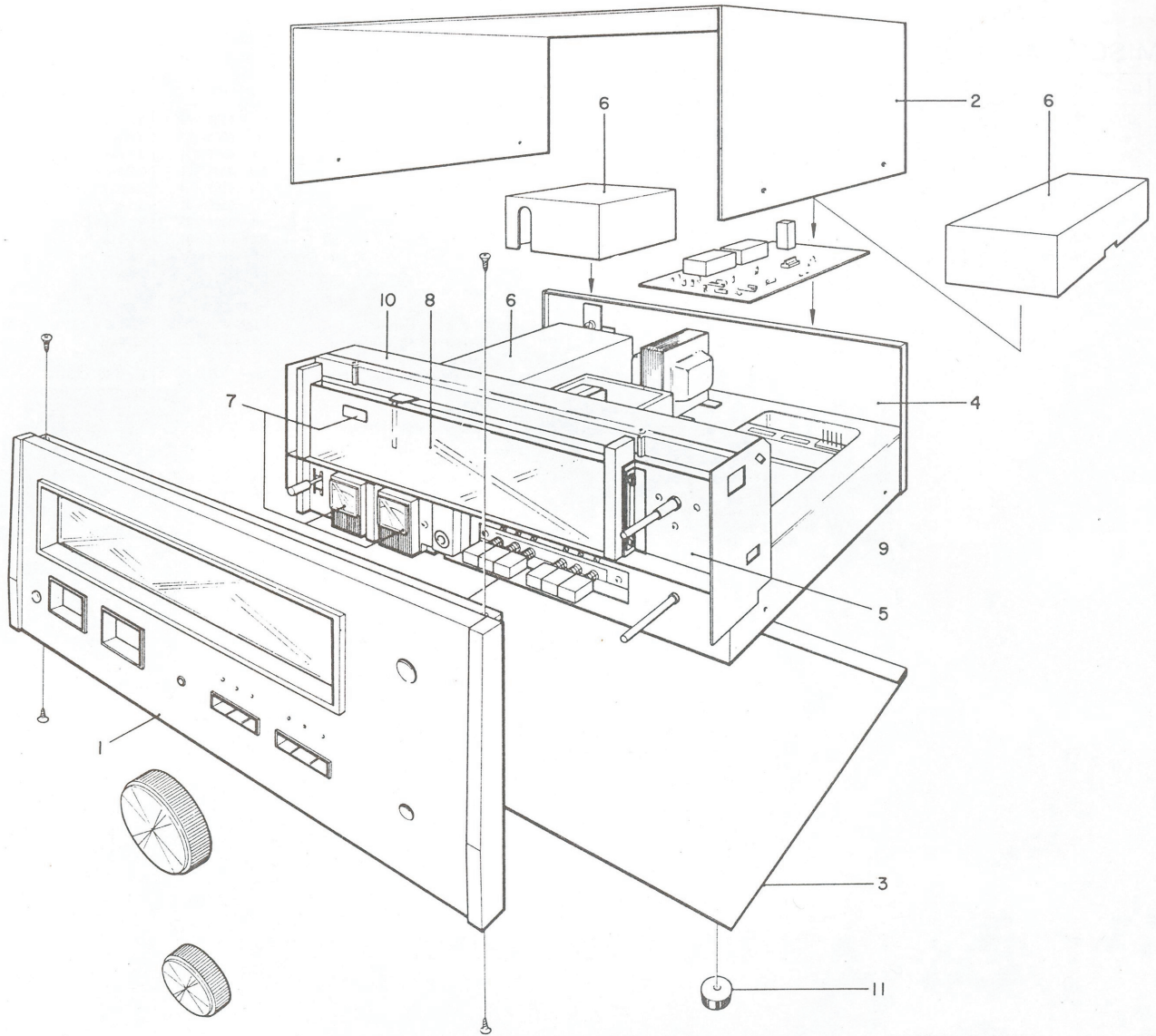

## ● PARTS LIST

No.	Description	Part No.	Remarks
1	Front Panel Assembly	130-0005-23	
	Front Panel	131-0005-02	
	Panel End Cap (L)	132-0005-04	
	Panel End Cap (R)	132-0006-04	
	Panel End Spacer	250-1001-14	
	Front Glass	172-0001-03	
	Front Glass Fixed Bracket	248-0010-14	
	Dial Frame	112-6001-00	
	Meter Frame	113-0005-03	
	Push-button Frame	113-0007-04	
	Push-button Frame	113-0008-14	for Power Switch.
	Indicator Assembly	173-1202-06	Stereo Indicator.
	Position Indicator	173-0901-14	Ref, EXTERNAL VIEW
	Position Filter	179-0011-04	④ ⑤
2	Case	100-0001-01	
3	Bottom Plate	155-0004-12	
4	Rear Panel	135-0005-12	
5	Dial Back Board	117-0002-22	
	Dial Back Plate	180-9003-03	
6	Shield Case	231-0007-03	for { MPX & Audio. FM IF AMP.
	Front-end Shield Case	231-0008-03	

No.	Description	Part No.	Remarks
7	Meter		
	SIGNAL Meter	178-0001-10	
	TUNING Meter	178-1001-10	
	MULTIPATH Meter	178-9002-00	
	Lamp Fixed Bracket	247-0034-13	for S & T Meter.
	Lamp Fixed Bracket	247-0038-14	for MULTIPATH Meter.
	Meter Filter	179-0008-04	for S & T Meter.
	Meter Filter	179-0004-24	for MULTIPATH Meter.
	Pilot Lamp for S & T Meter	176-5401-00	8V/300mA Ref. 9
	Pilot Lamp for MULTIPATH Meter	176-4401-00	8V/150mA Ref. 9
8	Dial Glass	175-2002-03	
	Dial Glass Fixed Bracket (L)	248-0015-04	
	Dial Glass Fixed Bracket (R)	248-0016-04	
	Dial Glass Holder	249-0002-14	
	Dial Glass Filter	179-0010-04	
	Pilot Lamp	176-2301-00	8V/300mA Ref. 9
	Pilot Lamp Socket	305-2201-00	
9	Pilot Lamp (8V/300mA)	176-2301-00	for Dial Scale.
	Pilot Lamp (8V/150mA) with wire.	176-4401-00	for Indicator.
	Pilot Lamp (8V/300mA) with wire.	176-5401-00	for S & T Meter.
10	Dial Shield Cover	230-0012-02	
11	Plastic Foot	238-0001-14	

## MISCELLANEOUS

No.	Description	Part No.	Remarks
D1	Silicon Diode	1BZ61	
	Fuse for Main Fuse At 100, 117V	310-1051-00	0.5A SLO-BLO
	Fuse for Main Fuse At 220, 240V	310-1141-00	1.4A SLO-BLO
F1,2	Fuse	310-0101-00	1A
F3	Fuse	310-0301-00	3A
	Connector Plug	304-0601-00	
	Dial String	210-0001-00	6 Feet (180cm)
	Tuning Capacitor Drum	200-5401-00	
	Tension Spring	285-0001-04	
	Pulley	201-1401-00	
	Pulley Bushing	221-0601-04	
	Screw for		(1) Binding Head B Type Self Tapping Screw
			(2) Pan Head B Type Self Tapping Screw
			(3) Pan Head ISO Metallic Screw
			(4) Flat Head B Type Self Tapping Screw
	Case (Upper)	614-0306-02	3×6mm (1) 4pcs.
	Nylon Washer	637-1031-50	4pcs.
	Case (Side)	630-4101-02	4×10mm 4pcs.
	Washer	637-0041-02	4pcs.
	Front Panel	613-0308-01	3×8mm (4) 4pcs.
	Panel End Cap	617-0315-01	3×5mm (2) 4pcs.

No.	Description	Part No.	Remarks
	Rear Panel	614-0308-02	3×8mm (1) 7pcs.
	Bottom Plate	614-0308-02	3×8mm 8pcs.
	Dial Shield Cover	600-0306-01	3×6mm (3) 2pcs.
	Dial Shield Cover	614-0308-01	3×8mm (1) 1pc.
	Dial Shield Cover	251-6101-04	Hexa Head Boss 2pcs.
	Shield Case	600-0360-01	3×60mm (3) 4pcs.
	Front Shield Case	600-0304-01	3×4mm (3) 2pcs.
	Plastic Foot	600-0414-01	4×14mm (3) 4pcs.
R1	Carbon Film Resistor	RD142HA100J	10Ω ± 5% ½W
R2,3	Carbon Film Resistor	RD142HA104J	100kΩ ± 5% ½W
R4	Carbon Film Resistor	RD142HA225J	2.2MΩ ± 5% ½W
C2	Ceramic Capacitor	CK45F1H103Z	0.01μF ± 80% 50WV
C3	Mylar Film Capacitor	CQ93M2E103MUL	0.01μF ± 20% 250WV
C4	Electrolytic Capacitor	CE02W1A222	2200μF 10WV
	Accessories		
	Coaxial Connector Plug	301-7001-00	for 75Ω Coaxial Cable, 6mm dia.
	Stereo Cord	685-0401-00	
	Power Supply Cord	680-2201-00	
	Carton Box		
	Outer Box	800-0005-00	
	Inner Box	801-0005-00	
	Front Protector	803-0015-00	
	Side Protector(L)	803-0013-00	
	Side Protector(R)	803-0014-00	
	Top Protector	803-0017-04	

## HOW TO REPLACE THE FOLLOWING PARTS

### SIGNAL AND TUNING METER

Ref. Exploded View 7

1. Remove in order Case, Knobs(2) and Front Panel (4 screws).
2. Take out the Meter after removing the Cushion between the Meter and the Plastic Plate.
3. Attach Cushion (258-3055-04) to the new Meter, wire Meter in, and affix to Plastic Plate with adhesive.

### PILOT LAMP FOR THE DIAL SCALE

Ref. Exploded View 9

1. Take of the Case, Knobs and Front Panel.
2. Insert new lamp into Pilot Lamp Socket.

### PILOT LAMP FOR SIGNAL AND TUNING METERS

Ref. Exploded View 7

1. Remove Bottom Plate and take off the Rubber Bushing of the Pilot Lamp from the Lamp Fixed Bracket.
2. Prepare new lamp and push its Bushing into the lamp holding tip of the Fixed Bracket.

### MULTIPATH METER PILOT LAMP

Ref. Exploded View 7

1. Remove in order, Case, Dial Cover and Bottom Plate.
2. Remove Rubber Bushing from Lamp Fixed Bracket and insert new lamp.
3. The job can be finished by completing the wiring within the chassis.

### MULTIPATH METER

Ref. Exploded View 7 10

1. Remove Case, and then the Dial Shield Cover.
2. Remove Lamp from Lamp Fixed Bracket, and then take out Fixed Bracket.
3. Remove Meter and Meter Filter after loosening the Meter locking screw (Fixes meter in place from the rear).
4. Wire up new Meter and attach it, keeping the Meter Filter at its rear in place, as is.
5. Reattach the Lamp Fixed Bracket. This completes the job of replacing the Multipath Meter.

### REPLACEMENT OF POSITION INDICATOR LAMP AND PUSH BOTTOM SWITCH ASSEMBLY

Ref. Internal View 12

1. Take off the Bottom Plate.
2. Assembly can be taken out after removing the Push Switch Fixed Bracket from the Chassis interior.
3. Lamp can be replaced after taking off the Lamp Fixed Bracket from the Assembly.

### HOW TO REMOVE THE PRINTED CIRCUIT BOARD

FM IF AMP Assembly Ref. Exploded View 6  
MPX & AUDIO Assembly Ref. Internal View 1 4 10

1. Take off the Shield Case.
2. Board can be removed after the 6 screws holding it in place are taken off since only the Connector wires will then remain.

FRONT-END Assembly

Ref. Internal View 3 6

1. Just remove the Front-end Shield Case and the Front-end Shield Plate if all that is required is checking.
2. To take off the Front-end Assembly, the Tuning Drum, connecting wires and the screws holding the Assembly in place must be removed.

# FM IF AMP. ASSEMBLY (703-0002-00)

## ● PRINTED CIRCUIT BOARD

\* Printed circuit board as seen from the reverse side.

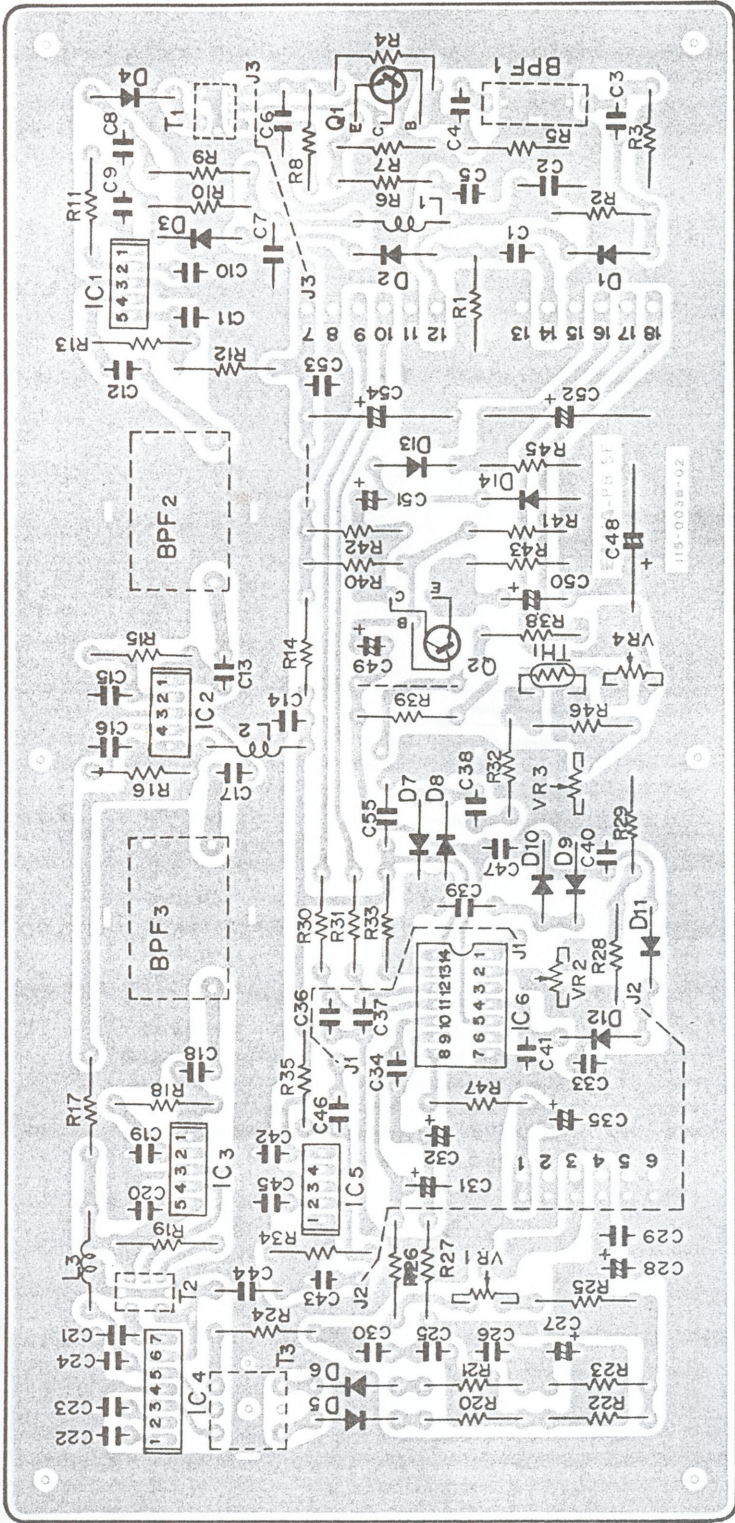

## ● PARTS LIST

No.	Description	Part No.	Remarks
IC1, 2, 3, 5	IC	TA7060P	
IC4	IC	TA7061AP	
IC6	IC	TA7106P	
Q1	Transistor	2SC381-0	
Q2	Transistor	2SC1746-GR or BL	
D1-14	Diode	1N60	
TH1	Thermistor	5D-19	
T1, 2	IFT	500-0002-00	
T3	FM Discriminator Transformer	505-0001-00	
L1, 2, 3	Choke Coil	506-1201-00	100mH
BPF1	IF Ceramic Filter	523-0001-00	
BPF2, 3	IF BPF	520-0001-00	
VR1	Potentiometer 2.2kΩ	580-0231-00	for Output Level Adj.
VR2	Potentiometer 470Ω	580-0521-00	for Muting Width Adj.
VR3	Potentiometer 1kΩ	580-0131-00	for Muting Level Adj.
VR4	Potentiometer 4.7kΩ	580-0531-00	for Signal Meter Adj.
	Connector Jack	304-5601-00	
	IC Socket	300-1141-00	for TA7106P
R1, 2, 9, 10, 10, 26, 27, 34, 47	Carbon Film Resistor	RD142HA103J	10kΩ ± 5% ½W
R28	Carbon Film Resistor	RD142HA331J	330Ω ± 5% ½W
R22, 23	Carbon Film Resistor	RD142HA332J	3.3kΩ ± 5% ½W
R7, 11, 25, 13, 16, 20, 21, 35, 39	Carbon Film Resistor	RD142HA102J	1kΩ ± 5% ½W
R6, 24, 46	Carbon Film Resistor	RD142HA101J	100Ω ± 5% ½W
R8	Carbon Film Resistor	RD142HA183J	18kΩ ± 5% ½W
R12	Carbon Film Resistor	RD142HA361J	360Ω ± 5% ½W
R14	Carbon Film Resistor	RD142HA750J	75Ω ± 5% ½W
R15, 18	Carbon Film Resistor	RD142HA561J	560Ω ± 5% ½W
R17	Carbon Film Resistor	RD142HA100J	10Ω ± 5% ½W
R19	Carbon Film Resistor	RD142HA272J	2.7kΩ ± 5% ½W
R33, 48	Carbon Film Resistor	RD142HA202J	2kΩ ± 5% ½W
R29	Carbon Film Resistor	RD142HA391J	390Ω ± 5% ½W
R30, 31	Carbon Film Resistor	RD142HA682J	6.8kΩ ± 5% ½W
R32	Carbon Film Resistor	RD142HA221J	220Ω ± 5% ½W
R38	Carbon Film Resistor	RD142HA563J	56kΩ ± 5% ½W
R40	Carbon Film Resistor	RD142HA104J	100kΩ ± 5% ½W
R41	Carbon Film Resistor	RD142HA333J	33kΩ ± 5% ½W
R42	Carbon Film Resistor	RD142HA472J	4.7kΩ ± 5% ½W
R43	Carbon Film Resistor	RD142HA222J	2.2kΩ ± 5% ½W
R45	Carbon Film Resistor	RD142HA471J	470Ω ± 5% ½W
R4	Carbon Film Resistor	RD142HA152J	1.5kΩ ± 5% ½W
R5	Carbon Film Resistor	RD142HA431J	430Ω ± 5% ½W
C1, 3, 4, 5, 8-24, 29, 33, 34, 36, 37, 38, 42, 44, 45, 47, 53	Ceramic Capacitor	CK45F1H103Z	0.01μF +80% -20% 50WV
C2, 6, 7, 55	Ceramic Capacitor	CK45F1H473Z	0.047μF +80% -20% 50WV
C25, 26, 30	Ceramic Capacitor	CC45SL1H221J	220pF ± 5% 50WV
C27, 28	Electrolytic Capacitor	CE04W1C100	10μF 16WV
C31, 32	Electrolytic Capacitor	CE04W1E3R3	3.3μF 25WV
C35, 49, 51	Electrolytic Capacitor	CE04W1H010	1μF 50WV
C39, 43, 46	Ceramic Capacitor	CC45SL1H220J	22pF ± 5% 50WV
C40	Ceramic Capacitor	CK45B1H471K	470pF ± 10% 50WV
C41	Ceramic Capacitor	CK45B1H821M	820pF ± 20% 50WV
C48, 52	Electrolytic Capacitor	CE02W0J101	100μF 6.3WV
C50	Electrolytic Capacitor	CE04W1E4R7	4.7μF 25WV
C54	Electrolytic Capacitor	CE02W1C101	100μF 16WV

# FM FRONT-END ASSEMBLY (700-0001-02)

● PRINTED CIRCUIT BOARD

\* Printed circuit board as seen from the reverse side.

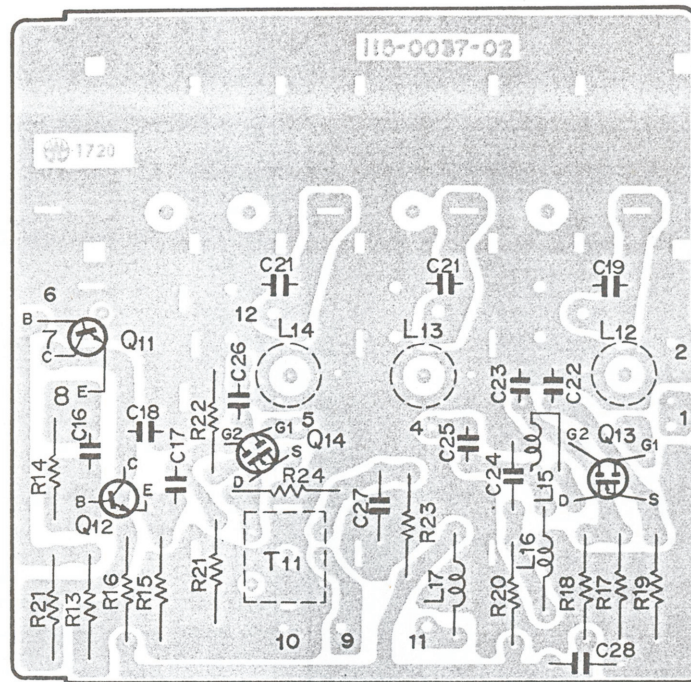

## ● PARTS LIST

No.	Description	Part No.	Remarks	No.	Description	Part No.	Remarks
Q11, 12,	Transistor	2SC785		C16	Ceramic Capacitor 10pF ±5% 50WV	CC45CH1H100J	Black(TC)
Q13, 14	MOS FET	3SK41		C17	Ceramic Capacitor 22pF ±5% 50WV	CC45CH1H220J	Black(TC)
T11	IFT	500-0001-00		C18, 24, 27, 28	Ceramic Capacitor 0.022μF $\begin{matrix} +80\% \\ -20\% \end{matrix}$ 50WV	CK45F1H223Z	
L11	OSC Coil	501-0004-00		C19, 20, 21	Ceramic Capacitor 12pF ±5% 50WV	CC45SH1H120J	Green(TC)
L12	ANT Coil	503-0006-00		C22, 23, 25, 26	Ceramic Capacitor 0.01μF $\begin{matrix} +80\% \\ -20\% \end{matrix}$ 50WV	CK45F1H103Z	
L13	RF Coil	502-0007-00		C29	Minic Capacitor 0.38pF ±10% 50WV	CC14SL1HR38K	(TC)
L14	RF Coil	502-0008-00		R11	Caroon Film Resistor 820Ω ±5% 1/4W	RD142EA821J	
L15	Choke Coil	506-0002-00	0.18mH	R12, 18	Caroon Film Resistor 12kΩ ±5% 1/2W	RD142HA123J	
L16	Choke Coil	506-1003-00	0.68mH	R13	Caroon Film Resistor 10kΩ ±5% 1/2W	RD142HA103J	
L17	Choke Coil	506-1002-00	1mH	R14	Carbon Film Resistor 8.2kΩ ±5% 1/2W	RD142HA822J	
CT1	Ceramic Trimmer	552-0601-00	6pF	R15	Carbon Film Resistor 1kΩ ±5% 1/2W	RD142HA102J	
CT2, 3, 4	Ceramic Trimmer Variable Condenser	552-1002-00 550-4001-00	10pF	R16	Carbon Film Resistor 560Ω ±5% 1/2W	RD142HA561J	
C11	Ceramic Capacitor 22pF ±5%50WV	CC45SH1H220J	Green(TC)	R17	Carbon Film Resistor 3.9kΩ ±5% 1/2W	RD142HA392J	
C12	Ceramic Capacitor 12pF ±5%50WV	CC45TH1H120J	Blue(TC)	R19	Carbon Film Resistor 22Ω ±5% 1/2W	RD142HA220J	
C13	Ceramic Capacitor 33pF ±5%50WV	CC45CH1H330J	Black(TC)	R20, 23	Carbon Film Resistor 470Ω ±5% 1/2W	RD142HA471J	
C14	Ceramic Capacitor 8pF ±5%50WV	CC45CH1H080J	Black(TC)	R21	Carbon Film Resistor 100kΩ ±5% 1/2W	RD142HA104J	
C15	Ceramic Capacitor 1000pF +100%-0%	CK183E102P		R22	Carbon Film Resistor 220Ω ±5% 1/2W	RD142HA221J	
				R24	Carbon Film Resistor 13kΩ ±5% 1/2W	RD142HA133J	



# MPX AUDIO ASSEMBLY (706-0002-00)

## ● PRINTED CIRCUIT BOARD

\* Printed circuit board as seen from the reverse side.

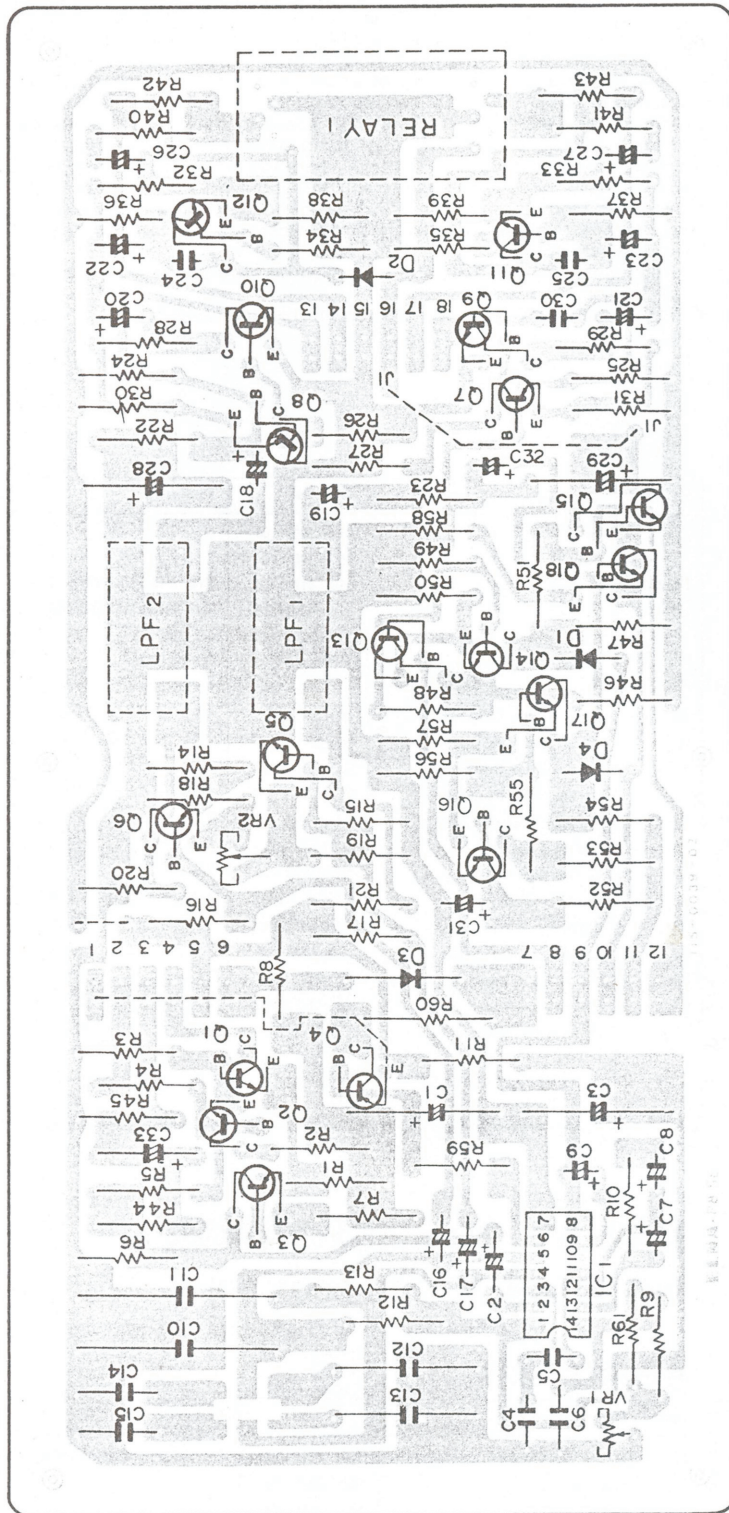

## ● PARTS LIST

No.	Description	Part No.	Remarks
IC1	IC	MC1310P	
Q1, 2	Transistor	2SC1746A-GR or BL	
Q3, 7, 8	Transistor	2SA856-Y or GR	
Q4	Transistor	2SA562-O or Y	
Q5, 6	Transistor	2SC1746-GR	
Q9, 10,	Transistor	2SC1746-GR or BL	
11, 12, 13,			
14, 15, 16,			
17, 18			
D1, 2, 3, 4	Silicon Diode	1S1555	
FIL 1, 2	Low Pass Filter	520-5001-10	
VR1	Potentiometer	4.7kΩ 580-0531-00	19kHz Osc Adj.
VR2	Potentiometer	100kΩ 580-0151-00	Separation Adj.
	IC Socket	300-1141-00	for MC1310P
S1	Slide Switch	350-0201-00	
RELAY 1	Reed Relay	363-1202-00	
	Connector Jack	304-5601-00	
R1, 2	Carbon Film Resistor	RD142HA682J	6.8kΩ ± 5% ½W
R3, 28, 29	Carbon Film Resistor	RD142HA472J	4.7kΩ ± 5% ½W
R4	Carbon Film Resistor	RD142HA153J	15kΩ ± 5% ½W
R5	Carbon Film Resistor	RD142HA134J	130kΩ ± 5% ½W
R6, 51	Carbon Film Resistor	RD142HA223J	22kΩ ± 5% ½W
R7	Carbon Film Resistor	RD142HA221J	220Ω ± 5% ½W
R8, 50, 57	Carbon Film Resistor	RD142HA471J	470Ω ± 5% ½W
R9	Carbon Film Resistor	RD142HA163J	16kΩ ± 5% ½W
R30, 31	Carbon Film Resistor	RD142HA102J	1kΩ ± 5% ½W
R11	Carbon Film Resistor	RD142HA151J	150Ω ± 5% ½W
R12, 13	Carbon Film Resistor	RD142HA7501G	7.5kΩ ± 2% ½W
R14, 15, 36, 37	Carbon Film Resistor	RD142HA154J	150kΩ ± 5% ½W
R16, 17	Carbon Film Resistor	RD142HA434J	430kΩ ± 5% ½W
R18, 19	Carbon Film Resistor	RD142HA152J	1.5kΩ ± 5% ½W
R20, 21, 59	Carbon Film Resistor	RD142HA222J	2.2kΩ ± 5% ½W
R22, 23, 48, 55	Carbon Film Resistor	RD142HA273J	27kΩ ± 5% ½W
R24, 25	Carbon Film Resistor	RD142HA392J	3.9kΩ ± 5% ½W
R26, 27	Carbon Film Resistor	RD142HA303J	30kΩ ± 5% ½W
R32, 33	Carbon Film Resistor	RD142HA183J	18kΩ ± 5% ½W
R34, 35	Carbon Film Resistor	RD142HA304J	300kΩ ± 5% ½W
R38, 39, 10	Carbon Film Resistor	RD142HA332J	3.3kΩ ± 5% ½W
R40, 41, 42, 43	Carbon Film Resistor	RD142HA560J	56Ω ± 5% ½W
R44	Carbon Film Resistor	RD142HA621J	620Ω ± 5% ½W
R45	Carbon Film Resistor	RD142HA104J	100kΩ ± 5% ½W
R46, 47, 49,	Carbon Film Resistor	RD142HA103J	10kΩ ± 5% ½W
53, 54, 56, 55			
R52	Carbon Film Resistor	RD142HA105J	1MΩ ± 5% ½W
R58	Carbon Film Resistor	RD142HA680J	68Ω ± 5% ½W
R60	Carbon Film Resistor	RD142HA150J	15Ω ± 5% ½W
C1, 3	Electrolytic Capacitor	CE02W1C221	220 <sup>μ</sup> F 16WV
C2	Tantalum Solid Capacitor	CS15E1C220M	22 <sup>μ</sup> F ± 20% 16WV
C4, 34	Ceramic Capacitor	CK45B1H471K	470pF ± 10% 50WV
C5	Mylar Film Capacitor	CQ93M1H473K	0.047 <sup>μ</sup> F ± 10% 50WV
C6, 14, 15	Polystyrene Film Capacitor	CQ08S2B471G	470pF ± 2% 125WV
C7, 9, 20,	Tantalum Solid Capacitor	CS15E1VR22K	0.22 <sup>μ</sup> F ± 10% 35WV
21, 22, 23			
C8	Tantalum Solid Capacitor	CS15E1VR47M	0.47 <sup>μ</sup> F ± 20% 35WV
C10, 11	Polystyrene Film Capacitor	CQ08S2B682G	6800pF ± 2% 125WV
C12, 13	Polystyrene Film Capacitor	CQ08S2B432G	4300pF ± 2% 125WV
C16, 17	Tantalum Solid Capacitor	CS15E1VOR1M	0.1 <sup>μ</sup> F ± 20% 35WV
C18, 19, 26, 27	Tantalum Solid Capacitor	CS15E1C100M	10 <sup>μ</sup> F ± 20% 16WV
C24, 25	Polystyrene Film Capacitor	CQ08S2B471J	470pF ± 5% 125WV
C28, 29	Electrolytic Capacitor	CE02W1C101	100 <sup>μ</sup> F 16WV
C30	Mylar Film Capacitor	CQ93M1H103M	0.01 <sup>μ</sup> F ± 20% 50WV
C31	Tantalum Solid Capacitor	CS15E0F100M	10 <sup>μ</sup> F ± 20% 3.15WV
C33	Electrolytic Capacitor	CE02W1C100	10 <sup>μ</sup> F 16WV
C35	Ceramic Capacitor	CC45SLIH220J	22pF ± 5% 50WV
C36, 37	Ceramic Capacitor	CK45B1H471K	470pF ± 10% 50WV

# HOW TO RE-STRING THE DIAL MECHANISM

1. Prepare a Dial String that is 6 feet long. (80 cm)
2. Connect one end to the Tension Spring as shown in Figure 1.
3. Hook the other end of the Tension Spring through a hole in the spoke of the Tuning Capacitor Drum as shown in Figure 2.
4. Now attach the spring end of the Tension Spring to the protruding hook at the rim of the Drum.
5. Set Drum so that its protruding hook is at the top when the Variable Capacitor Plates are fully meshed. (maximum capacity)
6. Guide String exactly as shown from 1 to 5 in Figure 2.
7. Tie String (B) to (A) firmly three times at the protruding hook of the Drum.
8. Release the Tension Spring from the protruding hook of the Drum.
9. Turn the Tuning Shaft to see whether the Variable Capacitor works smoothly from closed (maximum capacity) to fully open position (minimum capacity)
- Now fix the Drum firmly to the Shaft.
10. With the Tuning Condenser fully closed, attach the Dial pointer lightly to the dial string at a point in line with  $\nabla$  ( $\blacktriangle$ ).
11. Lock the Dial Pointer to the string permanently by tightening the fingers of the metal clasp after confirming the accuracy of the pointer setting to the frequency of the broadcasting station.

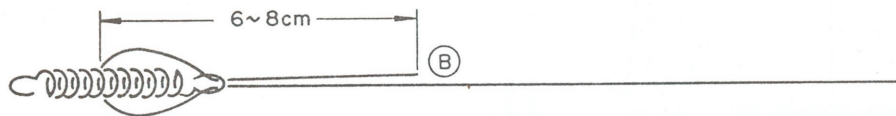

Fig. 1

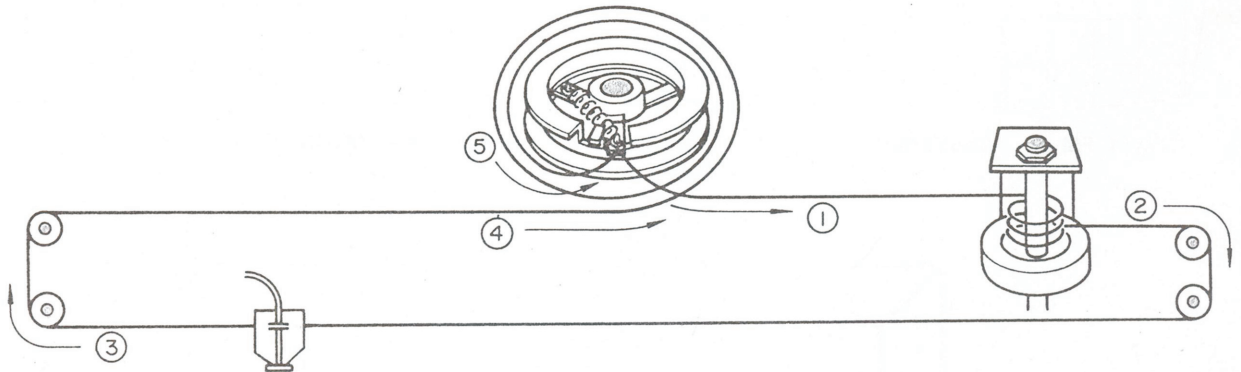
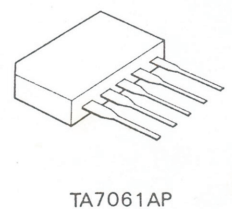
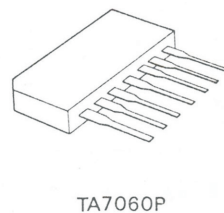
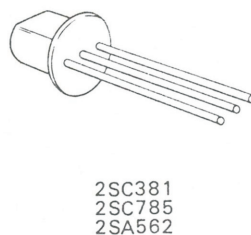
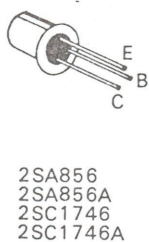
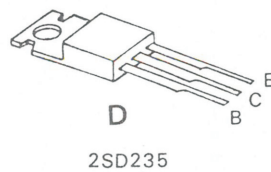
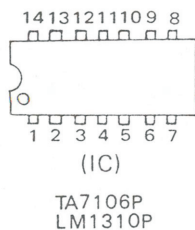
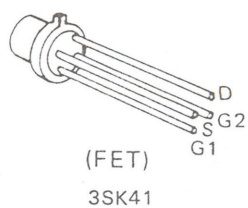

Fig. 2

## TRANSISTOR LEADS



# POWER SUPPLY ASSEMBLY (719-0006-00)

## ● PRINTED CIRCUIT BOARD

\* Printed circuit board as seen from the reverse side.

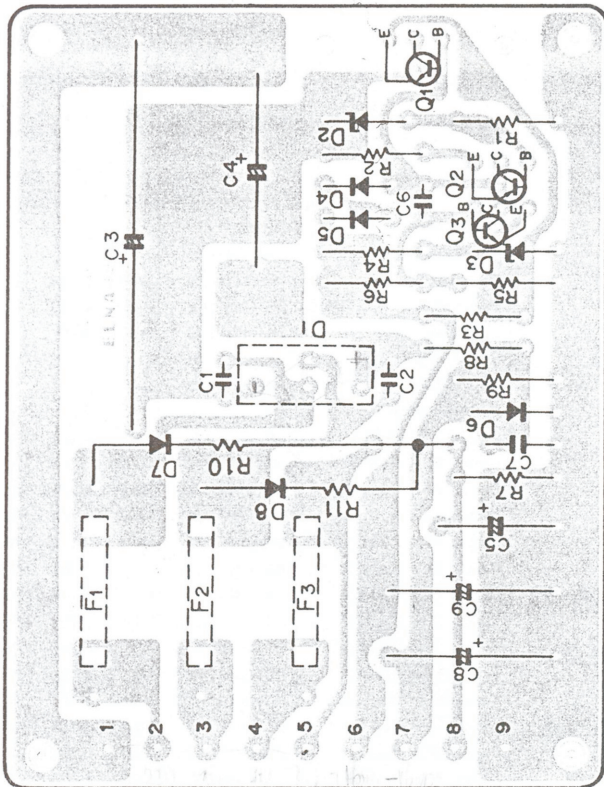

## POWER SUPPLY PROTECTION

A Slow-Blow type fuse which is unaffected by initial "rush" currents is employed in the primary side of the power transformer. Since temporary current surges such as initial "rush" currents can cause ordinary type fuses to blow, it is general practice with such fuses to adopt a rating that is considerably higher than the normal current flow. This, of course, reduces the protective function of a fuse, so a slow-blow fuse has been employed in this amplifier to increase the safety factor.

On the other hand, a short circuit may occur in the power transformer secondary circuit (such as the pilot lamp circuit) which may not cause the fuse on the primary side to blow. Therefore, a fuse is also inserted in the secondary circuit to counteract this possibility and prevent the transformer from overheating. This fuse is mounted on a printed circuit board located in the chassis interior. Check this fuse in case of the following indications:

- Pilot lamps fail to light although all other operations are normal. → (F3)
- No output when the power switch is turned ON. → (F1, 2)

## ● PARTS LIST

No.	Description	Part No.	Remarks
Q1	Transistor	2SD235-0 or Y	
Q2	Transistor	2SA562-0 or Y	
Q3	Transistor	2SC735-0 or Y	
D1	Silicon Diode Bridge	S1RB-10	
D2	Zener Diode	XZ-053	
D3	Zener Diode	XZ-060	
D4,5	Silicon Diode	1S1555	
D6	Zener Diode	XZ-162	
D7,8	Silicon Diode	1S-1553	

No.	Description	Part No.	Remarks
	Heat Sink	240-1007-04	
	Fuse Holder	306-1001-00	
F1,2	Fuse (1A)	310-0101-00	Ref. MISCELLANEOUS
F3	Fuse (3A)	310-0301-00	Ref. MISCELLANEOUS
	Transistor Insulator	318-0201-00	for 2SD235
	Transistor Insulation Washer	318-1102-00	for 2SD235
R1	Carbon Film Resistor	RD142HA272J	2.7kΩ ± 5% 1/2W
R2	Carbon Film Resistor	RD142HA471J	470Ω ± 5% 1/2W
R3	Metal Film Resistor	RN143AA1R5JX	1.5Ω ± 5% 1W
R4	Carbon Film Resistor	RD142HA102J	1kΩ ± 5% 1/2W
R5, 7	Carbon Film Resistor	RD142HA152J	1.5kΩ ± 5% 1/2W
R6, 10, 11	Carbon Film Resistor	RD142HA222J	2.2kΩ ± 5% 1/2W
R8	Carbon Film Resistor	RD142HA821J	820Ω ± 5% 1/2W
R9	Carbon Film Resistor	RD142HA163J	16kΩ ± 5% 1/2W
C1, 2, 6	Caramic Capacitor	CK45F1H103Z	0.01μF +80% -20% 50WV
C3	Electrolytic Capacitor	CE02W1V222	2200μF 35WV
C4	Electrolytic Capacitor	CE02W1V101	100μF 35WV
C5	Electrolytic Capacitor	CE02W1A220	22μF 10WV
C7	Ceramic Capacitor	CK45F1H473Z	0.047μF +80% -20% 50WV
C8,9	Electrolytic Capacitor	CE02W1C101	100μF 16WV

# PUSH-BUTTON SWITCH ASSEMBLY (716-0011-00)

## ● PARTS LIST

No.	Description	Part No.	Remarks
	Push-button Switch	354-6401-00	
	Pilot Lamp (8V/150mA)	176-4401-00	Ref. EXPLODED VIEW®
R1	Carbon Film Resistor	RD142HA105J	1MΩ ± 5% 1/2W
C1	Electrolytic Capacitor	CE02W1H010	1μF 50WV

# BALUN TRANSFORMER ASSEMBLY (708-0001-00)

## ● PARTS LIST

No.	Description	Part No.	Remarks
	Balun Transformer	509-0001-00	Ref. EXTERNAL VIEW®
	Terminal	313-0021-00	
	Nut for Terminal	633-2031-01	

# CIRCUIT DESCRIPTION

## T-101 ALIGNMENT INSTRUCTIONS

All ACCUPHASE tuners are carefully aligned and tested at the factory using the finest available test equipment. All ACCUPHASE tuners will meet their published specifications when shipped from the factory.

After extensive operation, or servicing, it may be desirable to realign the tuner circuits for best performance. The alignment charts give complete information on the circuit realignment procedure for the T-101.

The test equipment listed (or it's equivalent) is necessary to properly align a T-101. The accuracy of the alignment will be directly related to the accuracy and calibration of the test equipment used.

If the necessary test equipment is not available, alignment should not be attempted. For additional information contact Technical Service Department of our ACCUPHASE Distributor.

## TEST EQUIPMENT REQUIRED

1. FM Signal Generator (Measurements 188 or equivalent)
2. VTVM
3. Multiplex Generator (Radio meter SMG 1, or equivalent)
4. 10.7MHz Generator (Preferably crystal controlled)
5. Oscilloscope (Commercial Grade or equivalent)
6. Harmonic Distortion Analyzer (Hewlett-Packard 333A or equivalent)

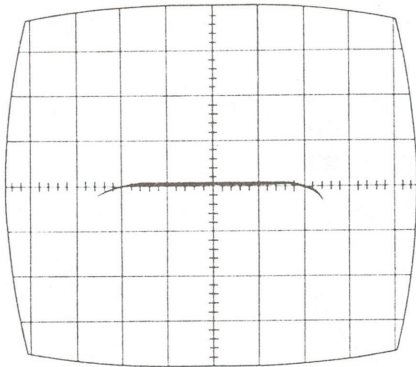

Fig. 1 FM IF WAVEFORM

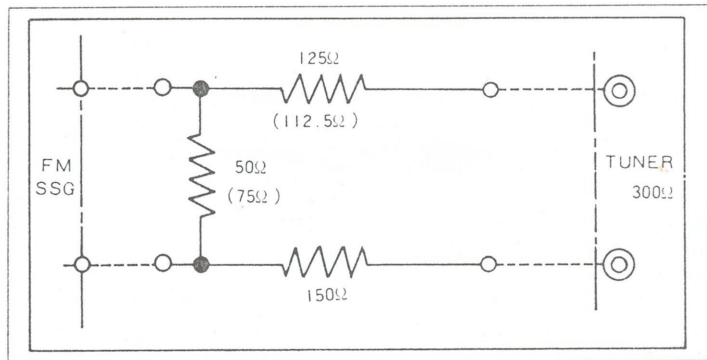

Fig. 2 FM ANTENNA MATCHING NETWORK

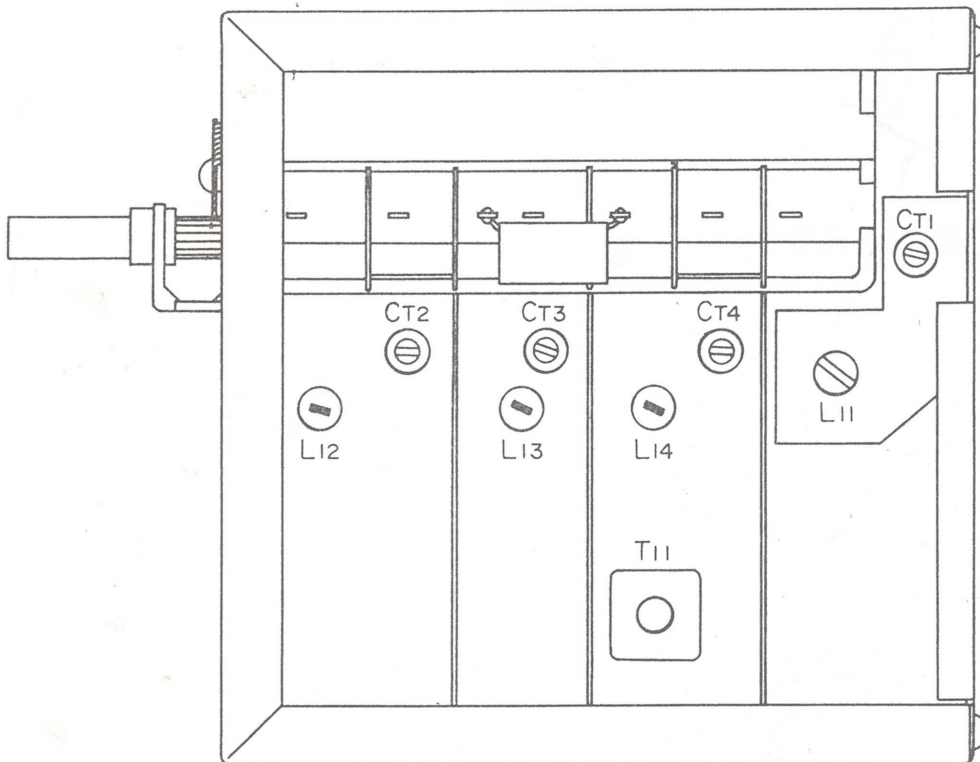
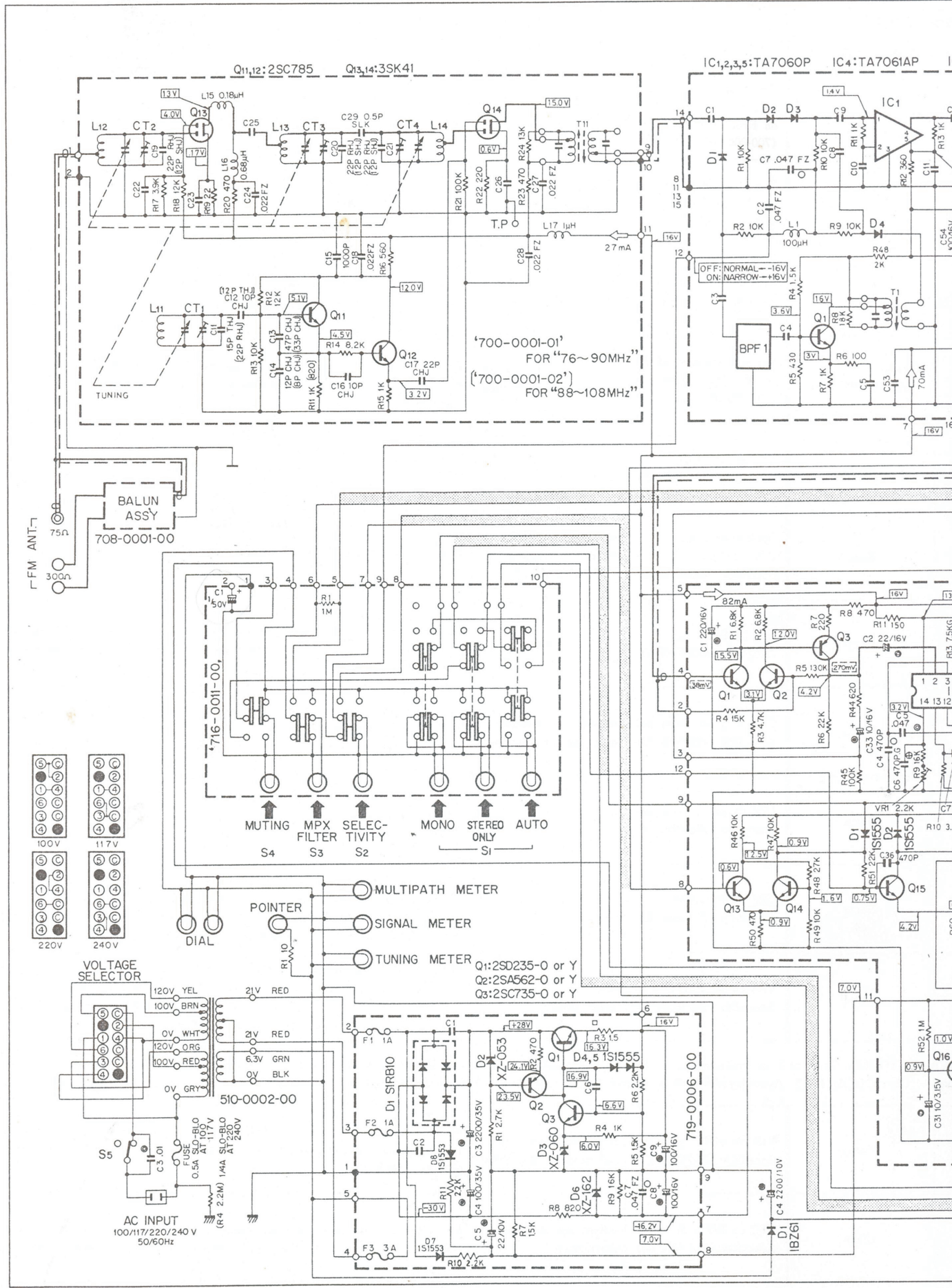
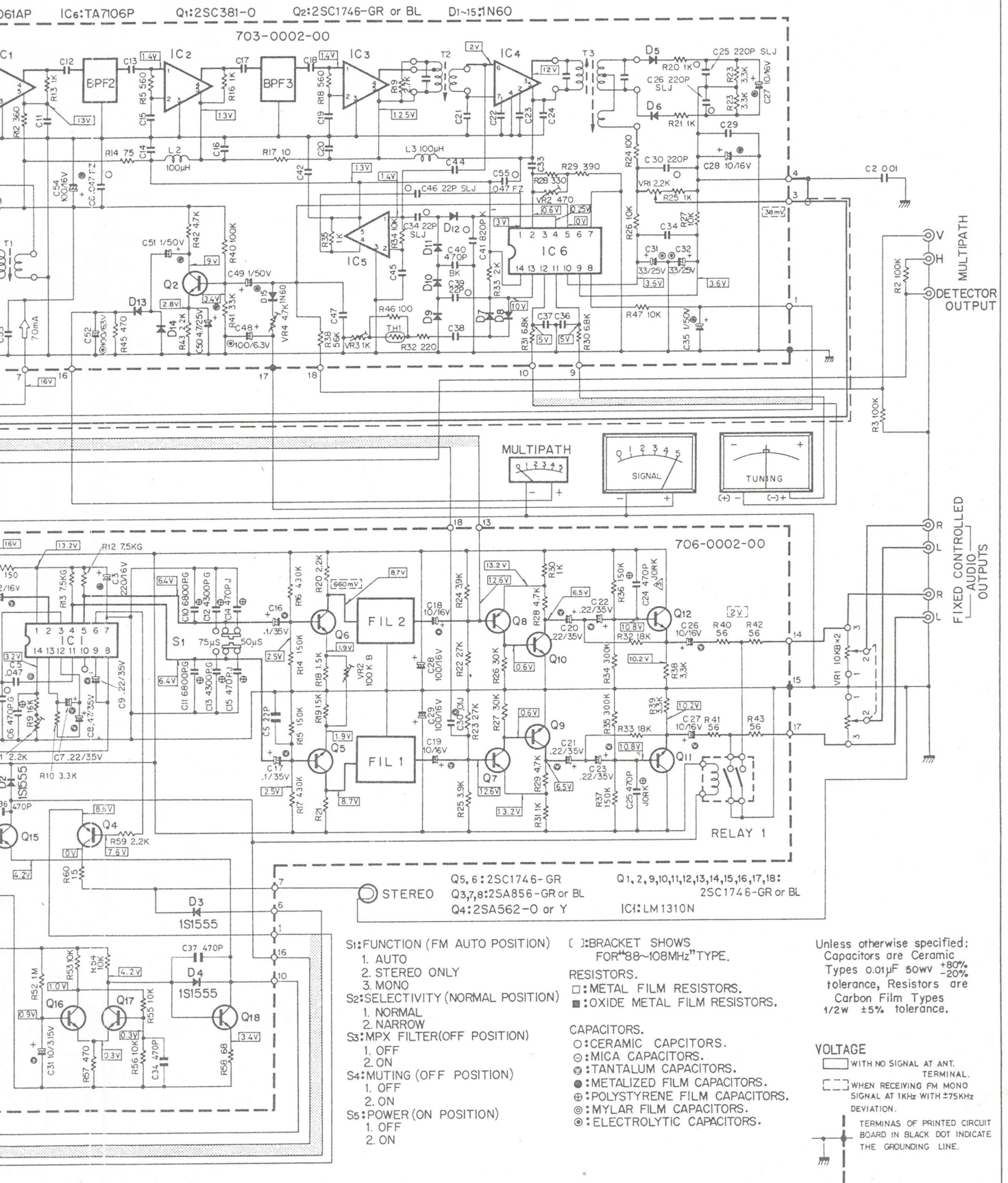

Fig. 3 ADJUST POINT ON FM FRONT-END ASSEMBLY

# T-101 REVISED SCHEMATIC DIAGRAM





# FM/MPX ALIGNMENT

STEP	ADJUST ITEM	TUNER DIAL SETTING	SIGNAL GENERATOR					INDICATOR	
			TYPE	FREQ	OUTPUT	COUPLING	MODURATION	TYPE	CON
1	IF	98MHz (Point of no interference around center)	FM Signal Generator	98MHz	14dB (5 $\mu$ V)	Through antenna matching network to 300 $\Omega$ ANT terminal	400Hz $\pm$ 22.5kHz deviation (30%)	Oscilloscope	Fixed MULT
2	DETECTOR	Point of no interference	Received FM noise					SIGNAL METER	
3	SIGNAL METER	106MHz	FM Signal Generator	106MHz	86dB	Through antenna matching network to 300 $\Omega$ ANT terminal	400Hz $\pm$ 22.5kHz deviation (30%)	SIGNAL METER	
4	DETECTOR	106MHz	Same	106MHz	66dB	Same	400Hz $\pm$ 75kHz deviation	Oscilloscope VTVM Distortion Meter	Fixed AUD
5	AUDIO OUTPUT	106MHz	Same	106MHz	66dB	Same	Same	Same	
6	CALIBRATION	106MHz	Same	106MHz		Same	Same	Same	
7	Same	90MHz	Same	90MHz		Same	Same	Same	
8	TRACKING	106MHz	Same	106MHz	12dB	Same	Same	Same	
9	Same	90MHz	Same	90MHz	12dB	Same	Same	Same	
10	MUTING WIDTH LEVEL	90MHz	Same	90MHz	86dB	Same	400Hz $\pm$ 22.5kHz deviation (30%)	Same	
11	MUTING LEVEL	90MHz	Same	90MHz	22dB	Same	Same	Same	
	Note:	Since the ANT. and RF circuits are double tuned, an RF sweep generator is necessary for realignment. Avoid touching parts in the circuit from the DETECTOR OUTPUT. If so, it will be an indication of some trouble within the MPX Assembly. The DE-EMPHASIS switch S1 should be in the OFF position.							
12	MULTIPLEX	100MHz	FM Signal Generator MULTIPLEX Generator	100MHz	66dB	Same	400Hz L-R	Same	
13	SEPARATION	100MHz	Same	100MHz	66dB	Same	400Hz L or R	Same	

INDICATOR		ADJUST	TEST LIMITS	REMARKS
	CONNECTED TO			
	Fixed MULTIPATH V and H	Top (secondary) and bottom(primary) of T11 on Front-end Assembly (700-0001-02)	Maximum height and best Symmetry curves as Fig.1	The alignment of T11 should be carried out first, then that of T2. Finally with the SELECTIVITY Control set to NARROW, align T1.
R		Top (secondary) of T3 on IF AMP. Assembly (703-0002-00)	Midpoint indication of TUNING METER	Keep TUNER in MONO mode with MUTING at OFF and SELECTIVITY at NORMAL.
R		VR4 on IF AMP. Assembly (703-0002-00)	"5" Point indication of SIGNAL METER	About 1/2 clockwise turn should produce a METER reading of "5". If unattainable repeat this step after completing step-9.
er	Fixed AUDIO OUTPUT	Bottom (primary) of T3 on IF AMP. Assembly (703-0002-00)	Maximum audio output and minimum distortion	Indicated by maximum deflection of the SIGNAL METER and midpoint indication of the TUNING METER. Distortion will be less than 0.2% if a high quality FM signal generator is used.
	Same	VR1 on IF AMP. Assembly (703-0002-00)	2.0V audio output	Same as above.
	Same	Oscillation trimmer CT1 on Front-end Assembly (700-0001-02)	Maximum SIGNAL METER. Midpoint TUNING METER	Keep FM signal generator output to obtain reading of "2.5" on the SIGNAL METER.
	Same	L11 on Front-end Assembly (700-0001-02)	Same	Keep repeating step-6 and 7 back and forth, until dial accurately indicates 90MHz and 106MHz during resonance with FM signal generator. Also check accuracy of other frequency reading.
	Same	CT2, 3, 4 on Front-end Assembly (700-0001-02)	Adjust for minimum noise and distortion	S/N will be more than 40 dB. Distortion less than 3%.
	Same	L12, 13, 14 on Front-end Assembly (700-0001-02)	Same	Same as above. Repeat step 8 and check again.
	Same	VR2 on IF AMP. Assembly (703-0002-00)	Adjust the working point	①Set VR2 to full counterclockwise position. ②Tune correctly. (maximum deflection of the S-Meter, Center indication of T-Meter) ③With MUTING set to ON, shift SSG frequency to the lower side of 50kHz. ④Turn VR2 clockwise to the position where output becomes available.
	Same	VR3 on IF AMP. Assembly (703-0002-01)	ON/OFF audio output	With MUTING set to ON, turn VR3 to full clockwise position. Then start turning it counterclockwise slowly and stop at the position where output signal appears. Then check the ON/OFF action of the Muting Switch by varying the output of the Sweep Signal Generator over a range by about 22dB.
parts in the FM Front-end for replacing parts thereof. If not audio output is obtained during step 4, see if it becomes available when an oscilloscope is connected switch S1 within the MPX Assembly (706-0002-00) should be set to 50 $\mu$ S or 75 $\mu$ S whichever conforms with the practice in the country in which this tuner is used.				
	Same	VR1 on MPX & Audio Assembly (706-0002-00)	Maximum audio output and minimum distortion	Be sure to tune correctly. If a Frequency Counter is to be used, set FM SSG modulation to CW and connect the counter to No.10 terminal of IC1. Then adjust VR1 for 19kHz.
	Same	VR2 on MPX & Audio Assembly (706-0002-00)	Adjust for Maximum Separation	Balance output of Left and Right channels by feeding identical signal alternately to each. Gain should become over 45dB when adjustments are made completely.



# SPECIFICATIONS

## PERFORMANCE GUARANTY:

Products of Accuphase guarantee specifications stated.  
All specifications are measured in accordance with the new  
IHF measurement method.

### Monophonic Performance

SENSITIVITY: Usable Sensitivity: 11 dBf (2.0  $\mu$ V\*)  
50 dB Quieting Sensitivity: 18 dBf (4.5  $\mu$ V\*)  
VOLTAGE STANDING WAVE RATIO: 1.5  
SIGNAL TO NOISE at 65 dBf (1 mV\*): 75 dB  
DISTORTION: with SELECTIVITY switch set to "NORMAL"  
65 dBf (1 mV\*) Input: 100 Hz 1,000 Hz 10,000 Hz  
0.1 % 0.1 % 0.2 %  
INTERMODULATION DISTORTION: will not exceed 0.2 %  
(Antenna input 65 dBf (1 mV\*), 100% mod., 14kHz and  
15kHz=1 : 1)  
FREQUENCY RESPONSE: +0, -1 dB 20 Hz to 15,000 Hz  
SELECTIVITY:  
with SELECTIVITY switch set to "NORMAL" "NARROW"  
Alternate Channel: 55dB 100dB  
Adjacent Channel: 6dB 20dB  
CAPTURE RATIO: 2.0dB  
RF INTERMODULATION: 70dB  
SPURIOUS RESPONSE RATIO: 100dB  
IMAGE RESPONSE RATIO: 80dB  
IF RESPONSE RATIO: 100dB  
AM SUPPRESSION RATIO: 55dB  
SUBCARRIER PRODUCT RATIO: 70dB  
SCA REJECTION RATIO: 60dB  
OUTPUT: 2.0 Volts

### Stereo Performance

SENSITIVITY: Usable Sensitivity: 31 dBf (20  $\mu$ V\*)  
50dB Quieting Sensitivity: 38 dBf ((45  $\mu$ V\*)  
SIGNAL TO NOISE at 65 dBf (1 mV\*): 70dB  
DISTORTION: with SELECTIVITY switch set to "NORMAL"  
65 dBf (1 mV\*) Input: 100Hz 1,000 Hz 10,000Hz  
0.2% 0.2% 0.5%  
INTERMODULATION DISTORTION: will not exceed 0.2%  
(Antenna input 65 dBf (1 mV\*), Standard Stereo mod. 10kHz)  
FREQUENCY RESPONSE: +0, -1dB 20Hz to 15,000Hz  
STEREO SEPARATION: 100Hz 1,000Hz 10,000Hz  
35dB 45dB 30dB  
STEREO AND MUTING THRESHOLD: 19 dBf (5  $\mu$ V\*)  
(\* old IHF methods at 300 ohms)

### General

TUNING CAPACITOR: Frequency Linear 4-gang  
OUTPUT IMPEDANCE: Audio Output FIXED: 200 ohms  
Audio Output CONTROLLED; 2.5K ohms  
FM ANTENNA INPUTS: 300-ohm balanced; 75-ohm unbalanced  
METERS: Signal Strength Meter Center Tuning Meter  
Multipath Meter  
TUNING RANGE: 88MHz to 108MHz  
POWER REQUIREMENT:  
Voltage selector for 100V, 117V, 220V, 240V 50/60Hz operation  
Consumption; 26 watts  
SEMICONDUCTOR COMPLEMENT:  
2 FET's, 7 IC's, 25 Transistors, 24 Diodes  
DIMENSIONS: 455mm (18 inches) wide, 152mm (6 inches)  
high, 355mm (14 inches) deep  
WEIGHT: 11.1 kgr. (24.4 lbs) net, 15.4 kgr. (33.8 lbs)  
in shipping carton.

MODEL

Issued AUG. 1982.

SUBJECT : Improvement of Relays at  
low level signal stage.

Effective Serial No.

Details;

Following new, high-reliable, closed type relays are currently employed for use of low-level signal path.

- For parts order, please refer to new numbers.

RECEIVED NOV 2 1982

	Part No.	
362-2403-00	→ 362-2404-00	or 362-2404-10
362-2205-00	→ 362-2212-00	or 362-2212-10
362-2208-00	→ 362-2208-10	

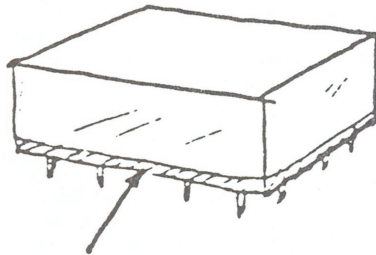

Closed Type



# Service Information

No. COM-009

MODEL

Issued Aug. 1982

SUBJECT : Re Substitution of  
Transistors

Effective Serial No.

## Details; Substitutions

### C-220 Power Supply Circuit

Q1,2,16,17,28,29 : 2SK30A-0 → 2SK117-0  
 Q13 : 2SK30A-GR → 2SK30A-Y  
 Q18 : 2SB435-0 or Y → 2SB834-0  
 Q19 : 2SD235-0 or Y → 2SD880-0  
 R11 : 470 ohms → Jumper Wire (to be changed)

### E-202/P-250

Power Supply Circuit

2SC1451-G or B → 2SC2229-0 or Y

### P-20

Protection Circuit

2SC1596-V/003 → 2SC2229-0 or Y

### P-300S/P-300/ E-202

Final Stage

2SA679-R → 2SB555-R  
 2SC1079-R → 2SD425-R

### P-300/ E-202

Main Drive Circuit

2SA809-V/002 } → 2SA939-B or V  
 2SA931-V/002 }  
 2SC1451-V/004 } → 2SC2071-B or V  
 2SC1596-V/003 }

### E-202 Equalizer Circuit

2SC1451-V/004 } → 2SC2071-B or V  
 2SC2229 }

### P-300S Main Drive Circuit

2SA810-B → 2SB648A-C  
 2SC1452-B → 2SD668A-C

### M-60 Main Drive Circuit

Q5,8,10,12 : 2SA809-V/002 → 2SA970-BL  
 Q6,7,9,11 : 2SC1451-V/004 → 2SC2240-BL

\*\*Q9,10,11,12 — with Heat Sink (240-2006-00)

Q13 : 2SA810-B/101 → 2SA818-0 or Y  
 Q14 : 2SC1452-B/101 → 2SC1628-0 or Y

D15,16 : CZ-060 → RD6.2F-B

For All Models

2SA856A-GR or BL → 2SA970-BL  
 2SC1746-GR or BL → 2SC2240-BL