

Accuphase

STEREO CONTROL AMPLIFIER C-200



Service Information

STARTING WITH SERIAL NO. J3Y101

TABLE OF CONTENTS

BLOCK DIAGRAM	1
EXTERNAL VIEW	2
INTERNAL VIEW	3, (6)
EXPLODED VIEW	4
MISCELLANEOUS	5
CIRCUIT DESCRIPTION	7
EQUALIZER AMP. ASSEMBLY	10
FUSE CIRCUIT ASSEMBLY	11
PUSH BUTTON SWITCH ASSEMBLY	11
TONE CONTROL ASSEMBLY	12
FILTER/OUTPUT ASSEMBLY	13
HEADPHONE AMP. ASSEMBLY	14
POWER SUPPLY ASSEMBLY	15
BASS CONTROL SWITCH ASSEMBLY	16
TREBLE CONTROL SWITCH ASSEMBLY	16
RESISTOR COLOR CODE	17
TRANSISTOR LEADS	18
SCHEMATIC DIAGRAM	19
SPECIFICATIONS	21

BLOCK DIAGRAM

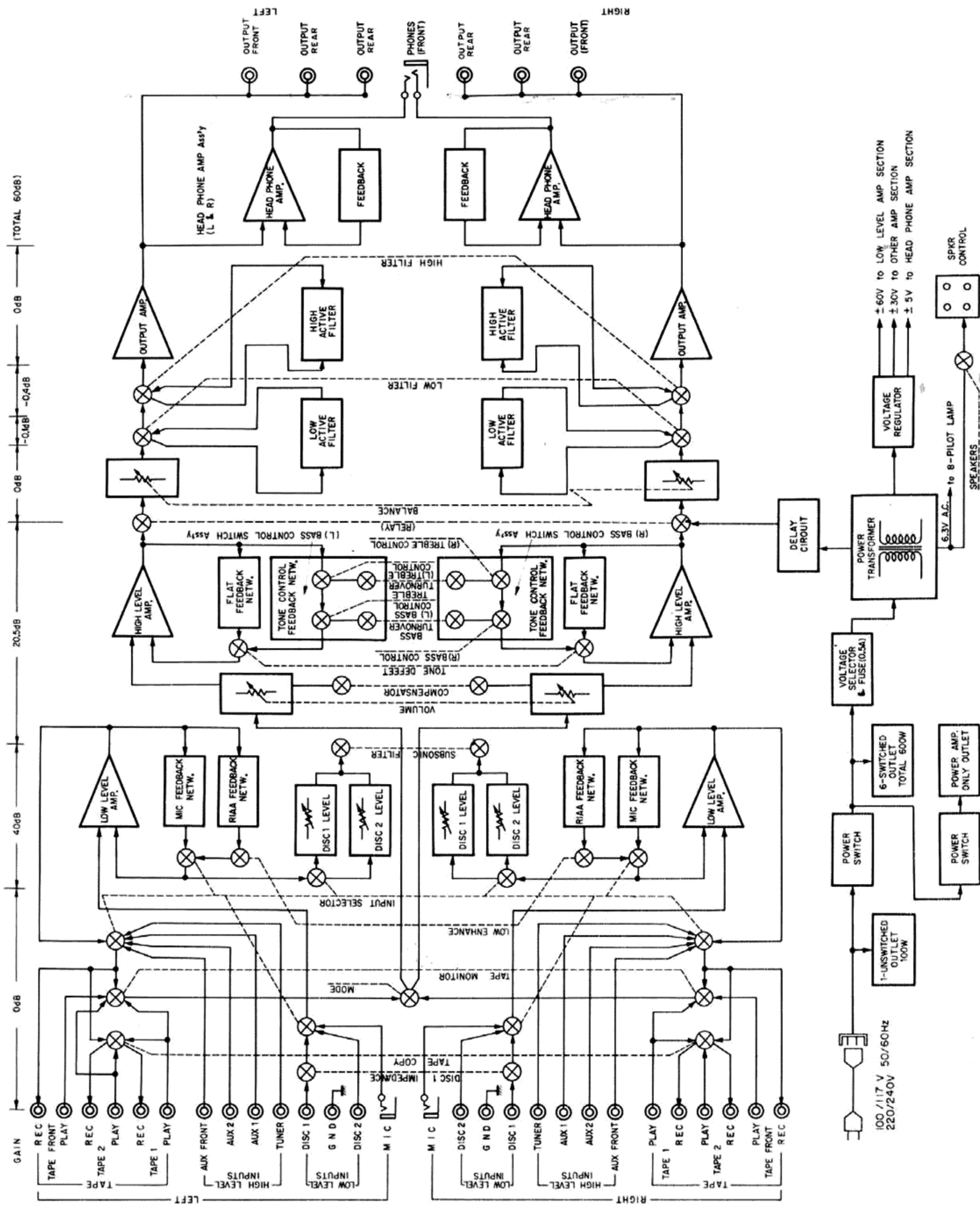

EXTERNAL VIEW

FRONT

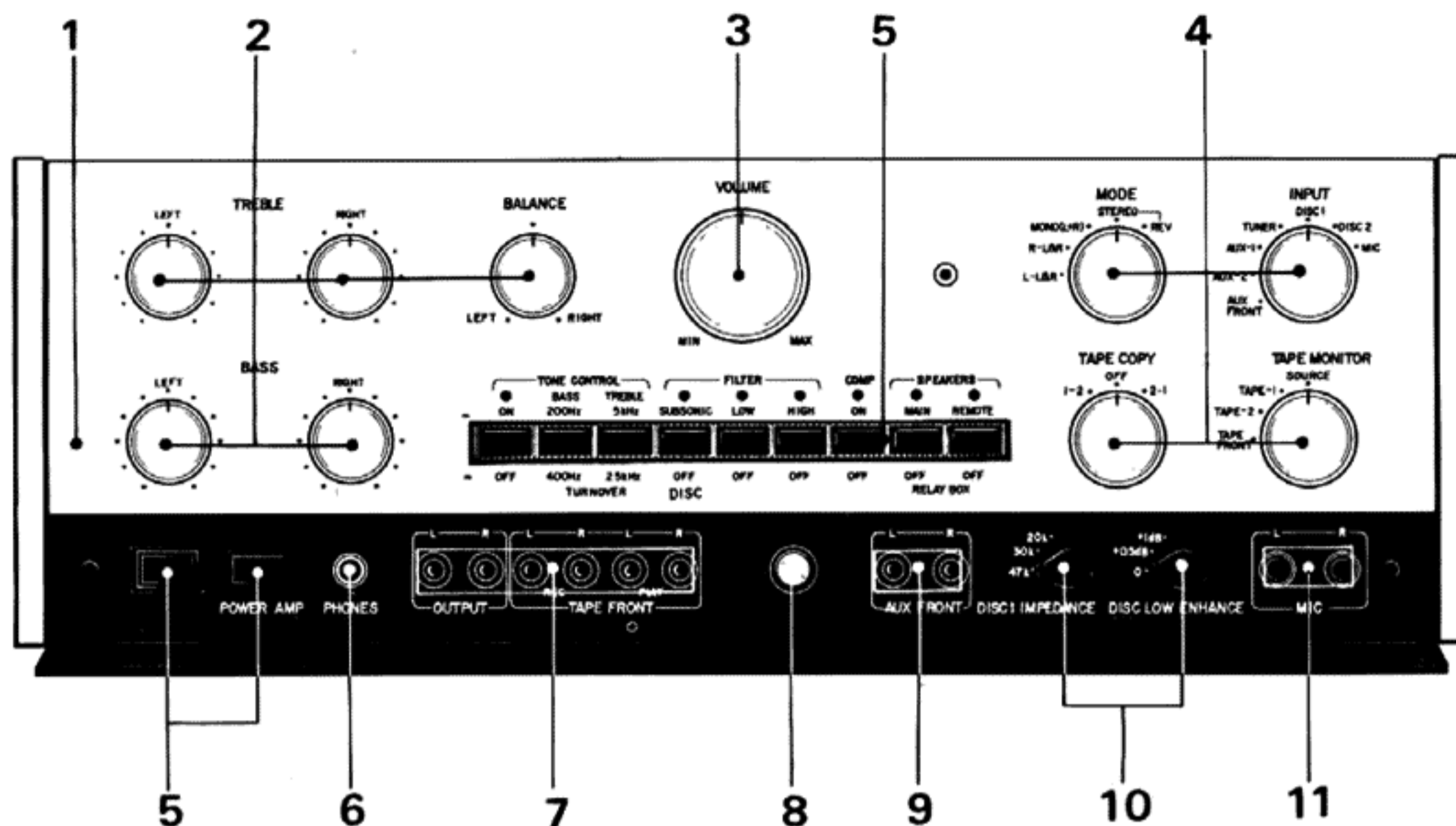

REAR

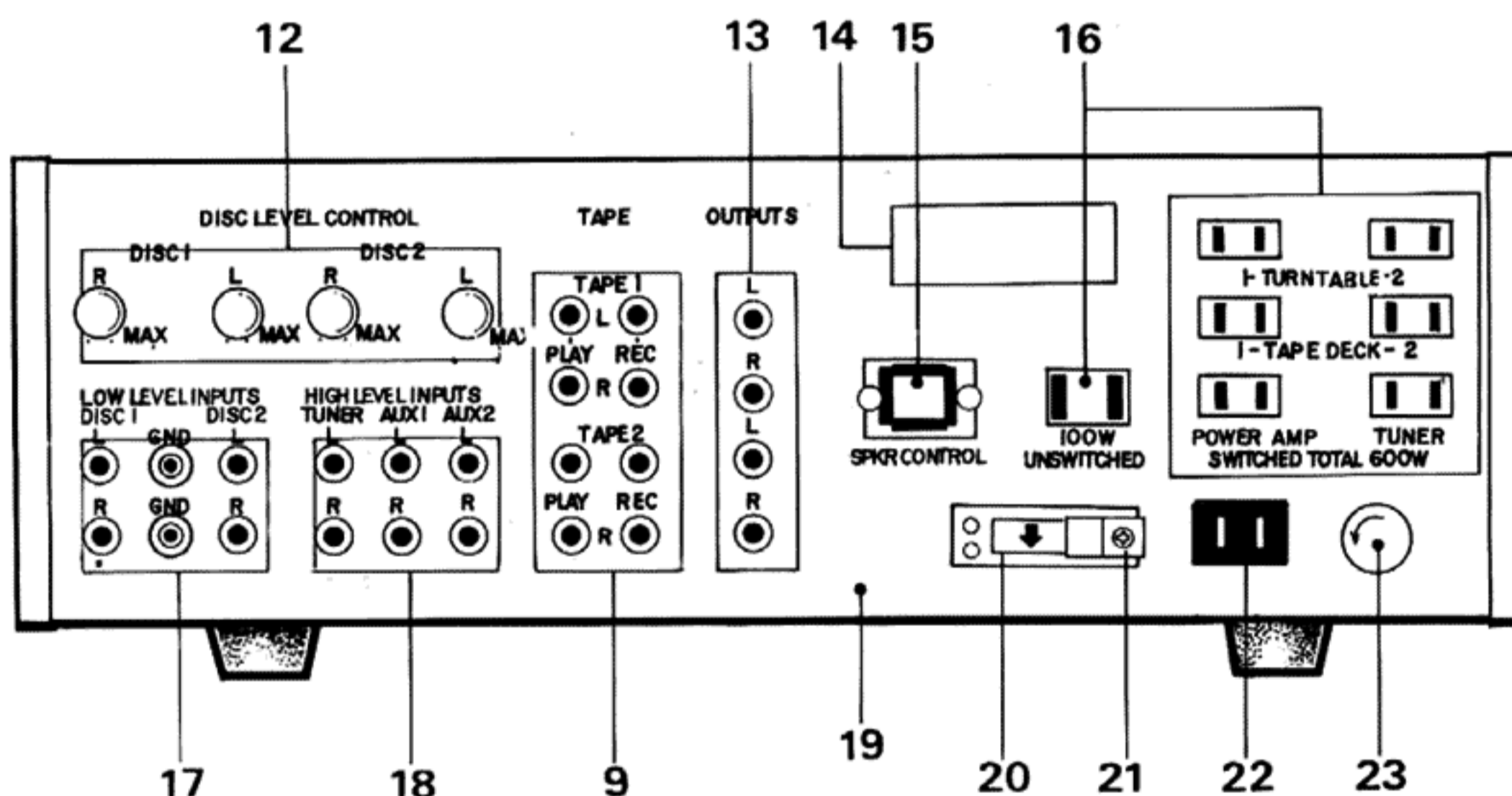

PARTS LIST

Ref. No.	Description	Part No.	Remarks
1	Front Panel Assembly	130-0001-00	
2	Knob	381-2603-00	for TREBLE, BASS, BALANCE
3	Knob	381-4003-00	for VOLUME
4	Knob	381-3003-00	for MODE, INPUT, TAPE COPY, TAPE MONITOR
5	Push button	389-5001-04	
6	Headphone Jack	302-1201-00	
7	Pin Jack	302-0601-00	6-pin
8	Push button	389-1203-00	with Magnet
9	Pin Jack	302-0201-00	2-pin
10	Knob	384-1101-04	
11	Phone Jack	302-1401-00	for Microphone
12	Knob	385-1801-04	for DISC LEVEL CONTROLS
13	Pin Jack	302-0101-00	1-pin for OUTPUTS
14	Set Name Plate	181-0001-24	
15	Square Type Connector	302-6401-00	
16	A. C. Outlet	305-1201-00	
17	Pin Jack	302-0901-00	2-pin with ground terminal
18	Pin Jack	302-0301-00	3-pin
19	Rear Panel	135-0007-02	
20	Voltage Selector Plug	301-4001-00	Voltage Selector Jack 302-4001-00
21	Voltage Selector Plug Fixed Bracket	248-0001-04	
22	AC. Connector Plug	301-3201-00	
23	Fuse Holder	306-0101-00	for MAIN FUSE

INTERNAL VIEW

Internal View shown below has been changed after from Serial No. L4W001.

TOP SIDE

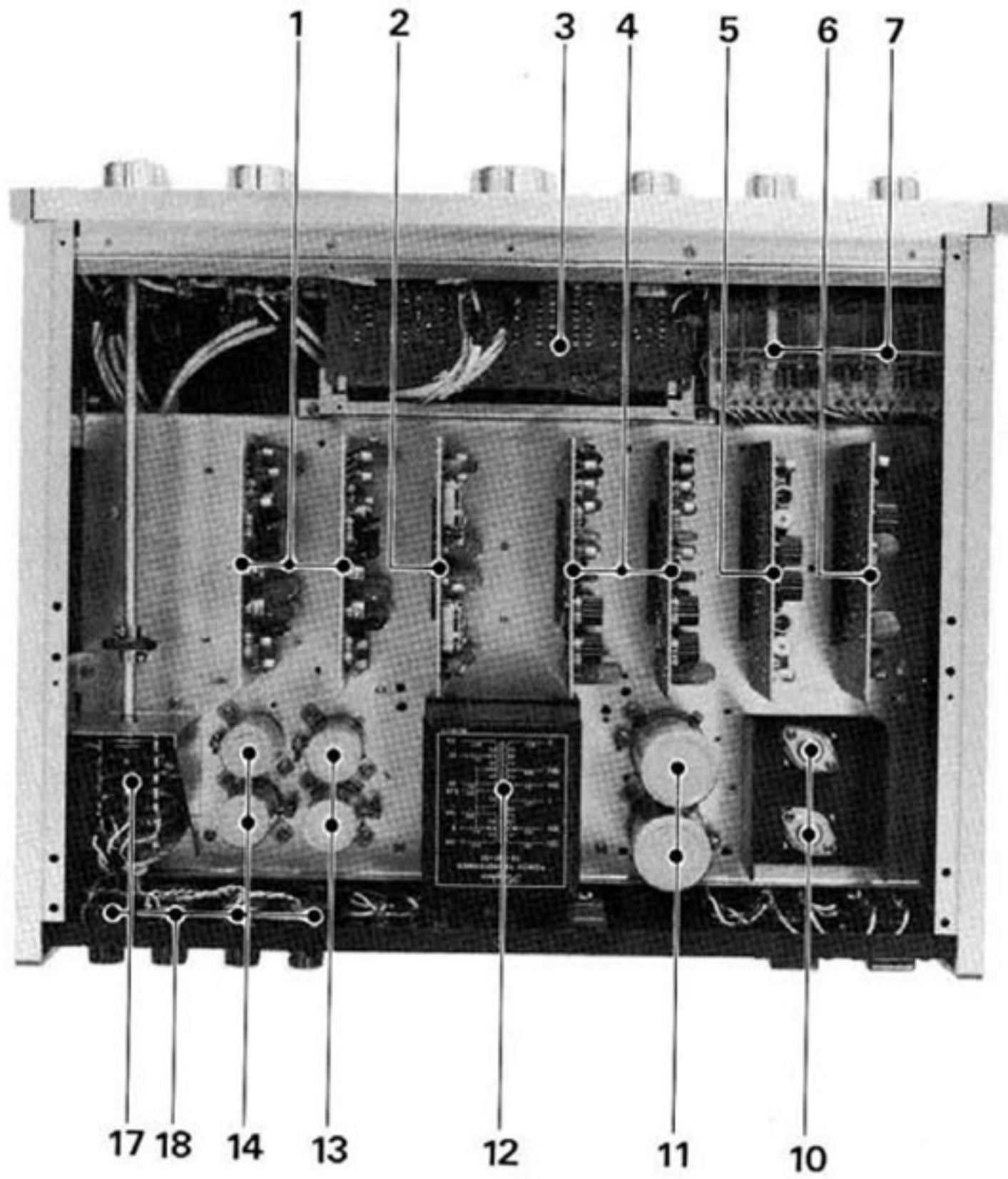

BOTTOM SIDE

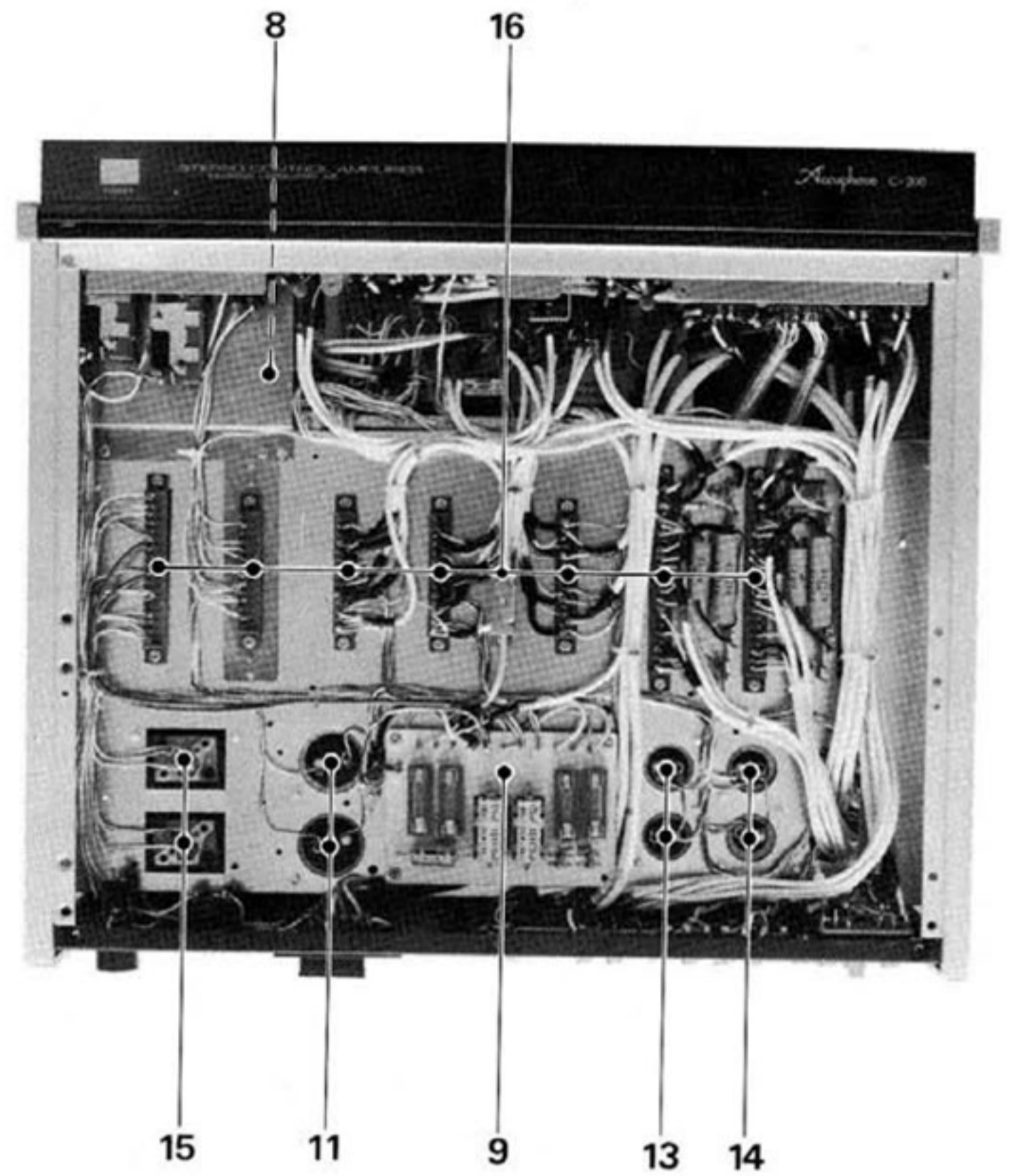

PARTS LIST

Ref. No.	Description	Part No.	Remarks	Ref. No.	Description	Part No.	Remarks
1	Equalizer AMP. Assembly	711-0001-00		13	Electrolytic Capacitor	CE62W0J103LG	C007, 008 10000 μ F 6.3WV
2	Tone Control AMP. Assembly	712-0001-00		14	Electrolytic Capacitor	CE62W1K102LG	C005, 006 1000 μ F 80WV
3	Push-button Switch Assembly	716-0002-00		15	Transistor Socket	300-0101-00	for Q1, Q2
	Bush-button Switch	354-9001-00		16	Printed Circuit Board Connector	303-1401-00	14-pin
4	Filter Output AMP. Assembly	714-0001-00			Printed Circuit Board Connector	303-1801-00	18-pin
5	Headphone AMP. Assembly	715-0001-00			Printed Circuit Board Connector	303-2201-00	22-pin
6	Power Supply Assembly	719-0001-00		17	Rotary Switch	332-7201-10	for S3, INPUT
7	TREBLE Control Assembly	716-0013-00			Shaft	203-5003-04	for INPUT
8	BASS Control Assembly	716-0001-00			Shaft Coupling	282-0001-00	for INPUT
9	Fuse Circuit Assembly	716-0014-00			Rotary Switch	332-5301-00	for S6, MODE
10	Transistor	2SA483-R	Q1		Rotary Switch	332-4002-00	for S5, TAPE MONITOR
	Transistor	2SC783-R	Q2		Rotary Switch	332-3001-00	for S4, TAPE COPY
	Headsink	240-1003-04	for Q1, Q2		Rotary Switch	336-1503-00	for ST1, TREBLE
	Transistor Insulator	318-0101-00	for Q1, Q2		Rotary Switch	336-1501-00	for SB1, BASS
11	Electrolytic Capacitor	CE62W2C102LG	C003, 004 1000 μ F 160WV		Rotary Switch	332-3002-10	for S1, DISC IMPEDANCE
12	Power Trans	510-1001-00		18	Variable Resistor	573-1103-00	for S2, LOW ENHANCE for VR1 ~ 4, DISC LEVEL

EXPLODED VIEW

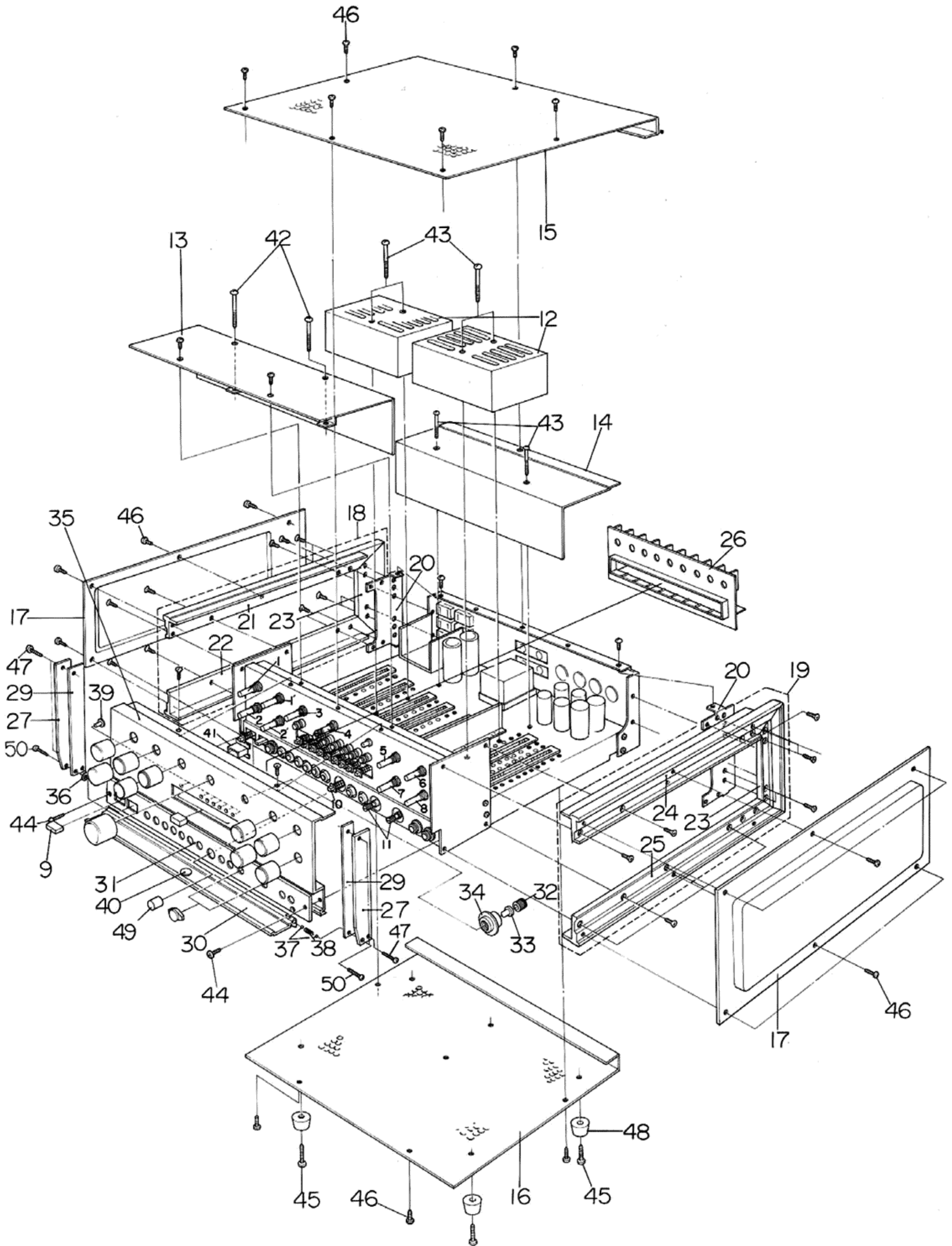

EXPLODED VIEW

PARTS LIST

Ref. No.	Description	Part No.	Remarks	Ref. No.	Description	Part No.	Remarks
1, 1'	Rotary Switch	336-1503-00	for ST1, TREBLE	26	Push-button Frame	113-0001-13	Front Panel Assembly: for Push-button Switch Assembly for left side
2, 2'	Rotary Switch	336-1501-00	for SB1, BASS	27	Panel End Cap (L)	132-0003-04	
3	Variable Resistor	573-2302-00	for VR6, BALANCE	28	Panel End Cap (R)	132-0004-04	for right side
4	Variable Resistor	573-2001-00	for VR5, VOLUME	29	Panel End Spacer	250-1001-14	
5	Rotary Switch	332-5301-00	for S6, MODE	30	Sub Panel	134-0001-42	
6	Rotary Switch	332-7201-10	for S3, INPUT	31	Panel Name Plate	180-1001-33	
7	Rotary Switch	332-3001-00	for S4, TAPE COPY	32	Indicator Holder	631-0804-04	32, 33, 34 → Position Indicator Assembly 173-1201-14 Red color
8	Rotary Switch	332-4002-00	for S5, TAPE MONITOR	33	Position Indicator	173-0201-04	
9	Push-button Switch	354-1002-00	for S7, POWER Switch S8, POWER AMP. Switch	34	Position Indicator Bracket	174-0001-14	
10	Push-button Switch	354-1201-00	for Sub Panel Magnet Opener	35	Front Panel	131-0001-02	
11	Rotary Switch	332-3002-10	for S1, DISC IMPEDANCE S2, LOW ENHANCE	36	Nylon Washer	637-1031-50	
12	Shield Case (Left side)	231-0011-02	for Printed Circuit Assembly for Printed Circuit Assembly	37	Ball Bearing	220-0301-00	
12'	Shield Case (Right side)	231-0010-03					
13	Sub Chassis Shield Cover	230-0024-02		38	Coil Spring	285-1001-04	
14	Back Panel Shield Cover	230-0023-02		39	Position Indicator	173-0901-14	
15	Top Plate	150-0001-02		40	Catcher	272-0001-04	Catch for Sub Panel Opener
16	Bottom Plate	155-0001-12		41	Push-button Frame	113-0002-04	for Power Switch
17	Side Plate	151-0001-02		42	Pan Head ISO Metric Screw	600-0375-01	3x75mm: Fixed for Sub Chassis Shield Cover
18	Frame Assembly (L)	112-0001-22		43	Pan Head ISO Metric Screw	600-0390-01	3x90mm: Fixed for Back Panel Shield Cover, Printed Circuit Board Assembly
19	Frame Assembly (R)	112-0002-22		44	Binding Head B type Self tapping Screw	614-0312-00	3x12mm: Fixed for Front Panel Assembly
20	Frame Fixed Plate	244-0001-04	Frame Assembly for both side rear	45	Pan Head ISO Metric Screw	600-0414-01	4x14mm: Fixed for Plastic Foot
21	Frame A	112-1001-23	Frame Assembly (L): for upper	46	Binding Head B type Self tapping Screw	614-0306-01	3x6mm: Fixed for SIDE, BOTTOM Plates
22	Frame B	112-1002-23	Frame Assembly (L): for bottom	47	Pan Head B type Self tapping Screw	610-0314-01	3x14mm: Fixed for Panel End Cap
23	Frame C	112-1003-04	Frame Assembly: for rear	48	Plastic Foot	238-0001-04	
24	Frame D	112-1004-23	Frame Assembly (R): for upper	49	Push-button	389-1203-00	with Magnet
25	Frame E	112-1005-23	Frame Assembly (R): for bottom	50	Pan Head ISO Metric Screw	615-0312-01	3x12mm: Fixed for Panel End Cap

MISCELLANEOUS

PARTS LIST

Ref. No.	Description	Part No.	Remarks	Ref. No.	Description	Part No.	Remarks
F1~3	Fuse	310-0101-00	1A } Ref: Fuse Circuit 2A } Assembly	C001, 002	Mylar Film Capacitor	CQ93M2E103MUL	0.01μF ±20% 250WV
F4	Fuse	310-0201-00					
	Fuse 0.5A SLO-BLO	310-1051-00	for Main Fuse at 100, 117V	C003, 004	Electrolytic Capacitor	CE62W2C102LG	1000μF 160WV
	Fuse ¼A SLO-BLO	310-1141-00	for Main Fuse at 220, 240V	C005, 006	Electrolytic Capacitor	CE62W1K102LG	1000μF 80WV
	Terminal	313-4031-00	3-terminal	C007, 008	Electrolytic Capacitor	CE62W0J103LG	10000μF 6.3WV
	Terminal	313-4041-00	4-terminal	C101, 102	Metallized Film Capacitor	CQ91M2E475M	4.7μF ±20% 250WV
	Lug Strip	315-1001-00		C103, 104	Metallized Film Capacitor	CQ91M2E225M	2.2μF ±20% 250WV
	Lug Strip	315-0011-00		C-105~112 C-301~303	Ceramic Capacitor	CK45E2H102P	1000pF +100% -0% 500WV
	Position Indicator Assembly	173-1201-14	for Pilot Lamp		Power Supply Cord	680-1201-00	
R101, 102	Carbon Film Resistor	RD142HA913J	91kΩ ±5% ½W		Stereo Cord	685-0402-00	4-pin
R117, 118	Carbon Film Resistor	RD142HA433J	43kΩ ±5% ½W		Carton Box		
R103, 104	Carbon Film Resistor	RD142HA433J	43kΩ ±5% ½W		Inner Box	801-0001-20	
R105~112	Carbon Film Resistor	RD142HA472J	4.7kΩ ±5% ½W		Outer Box	800-0001-20	
R113, 114	Carbon Film Resistor	RD142HA222J	2.2kΩ ±5% ½W		Front Protector	803-0001-00	
R115, 116	Carbon Film Resistor	RD142HA104J	100kΩ ±5% ½W		Rear Protector	803-0002-00	
R201, 202	Carbon Film Resistor	RD142HA101J	100Ω ±5% ½W				

INTERNAL VIEW

This diagram shows the Internal View of the parts location for earlier Model C-200 units.

TOP SIDE

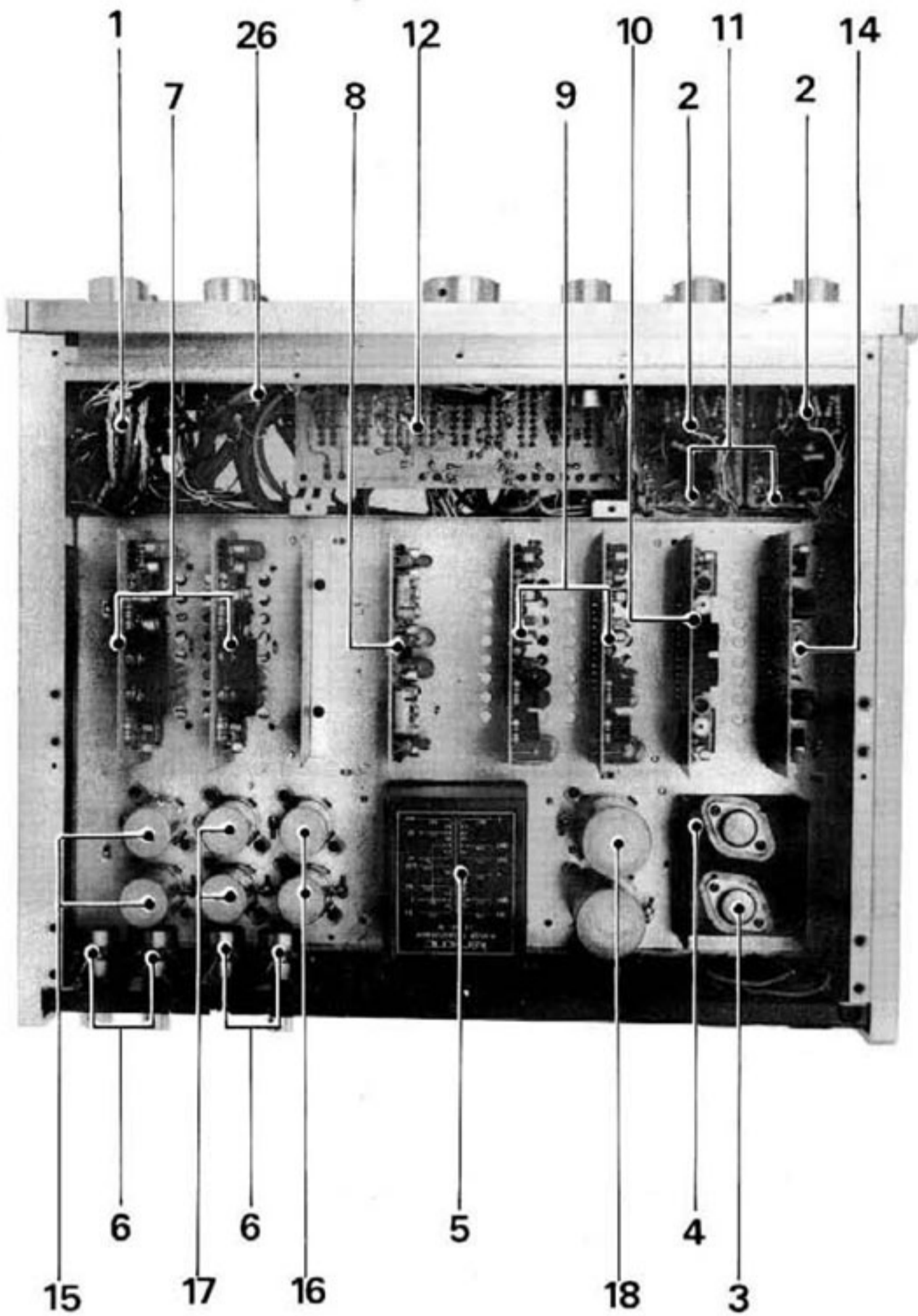

BOTTOM SIDE

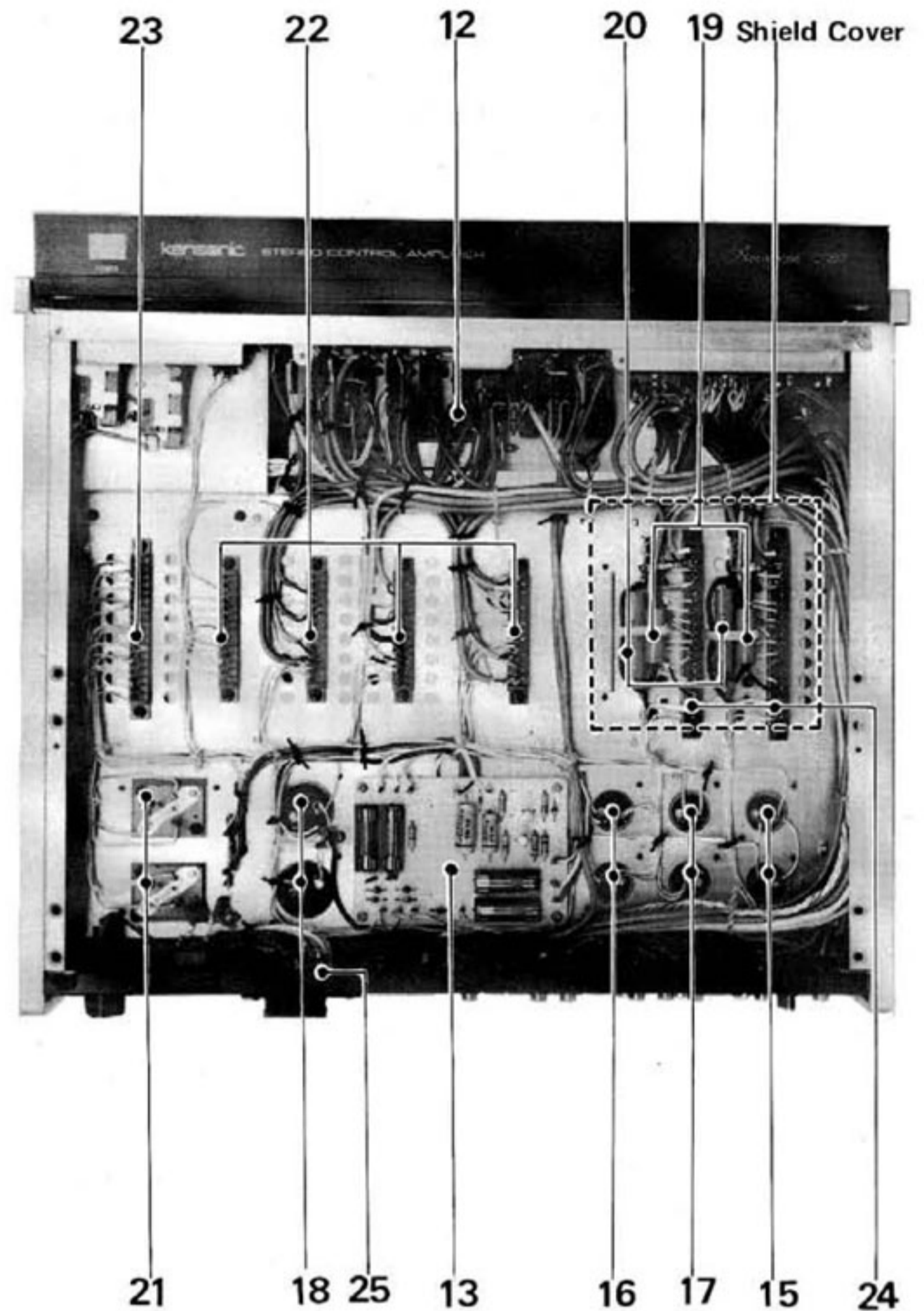

PARTS LIST

Ref. No.	Description	Part No.	Remarks
1	Rotary Switch	332-7201-00	S3 INPUT SELECTOR
2	Rotary Switch	332-1501-00	S7, 8 TREBLE
3	Transistor PNP	2SA483R	Q1
4	Transistor NPN	2SC783R	Q2
5	Power Transformer	510-1001-00	
6	Variable Resistor 5kΩB	573-2201-00	VR, 2, 3, 4: DISC Level
7	Equalizer AMP. Assembly	711-0001-00	
8	Tone Control Assembly	712-0001-00	
9	Filter Output AMP. Assembly	714-0001-00	
10	Headphone AMP. Assembly	715-0001-00	
11	Base Control Assembly	716-0001-00	
12	Push button Switch Assembly	716-0002-00	
13	Fuse Circuit Assembly	716-0003-02	
14	Power Supply Assembly	719-0001-00	
15	Electrolytic Capacitor 10000μF 6.3WV	CE62WOJ103LG	C23, 24
16	Electrolytic Capacitor 2200μF 35WV	CE62W1V222LG	C21, 22
17	Electrolytic Capacitor 1000μF 80WV	CE62W1K102LG	C19, 20
18	Electrolytic Capacitor 1000μF 160WV	CE62W2C102LG	C17, 18
19	Metalised Capacitor 2.2μF ±20% 250WV	CQ91M2E225M	
20	Metalised Capacitor 4.7μF ±20% 250WV	CQ91M2E475M	
21	Transistor Socket	300-0101-00	
			for 2SA483R, 2SC783R
22	Printed Circuit Board Connector	303-1401-00	14-pin
23	Printed Circuit Board Connector	303-1801-00	18-pin
24	Printed Circuit Board Connector	303-2201-00	22-pin
25	Voltage Selector jack	302-4001-00	
26	Rotary Switch	332-5301-00	S6: MODE

CIRCUIT DESCRIPTION

1. BASIC CIRCUIT

The circuitry of this control amplifier is based on a complementary—symmetrical, push-pull amplification system that is powered by positive, negative dual power supplies. Fig. 1 illustrates its basic principle. Q1 and Q2 comprise a NPN type differential amplifier system while Q4 and Q5 form, a PNP type differential amplifier. This circuit has numerous advantageous features including high gain, good thermal stability and low distortion amplification due to the ease in applying stabilized negative feedback.

Q3 and Q6 are common emitter amplifiers that respectively constitute constant current loads that enable high stability amplification.

Circuits that require wide dynamic range and low output impedance such as equalizer and headphone amplifiers are all further connected into complementary-symmetry stages.

In servicing a C-200, bear in mind that —

- a. All circuits within a circuit block are direct coupled.
- . Gain is determined by Z1 and Z2 (Negative Feedback loop).
- c. Circuits such as equalizer amplifier and tone control which control frequency response do so by varying the frequency response characteristics of Z1 and Z2. Since Z2 is not grounded in terms of DC in almost all circuits, direct current becomes 100% NF. As a result, the electric potential of the output stage collector never exceeds ± 50 mV DC.

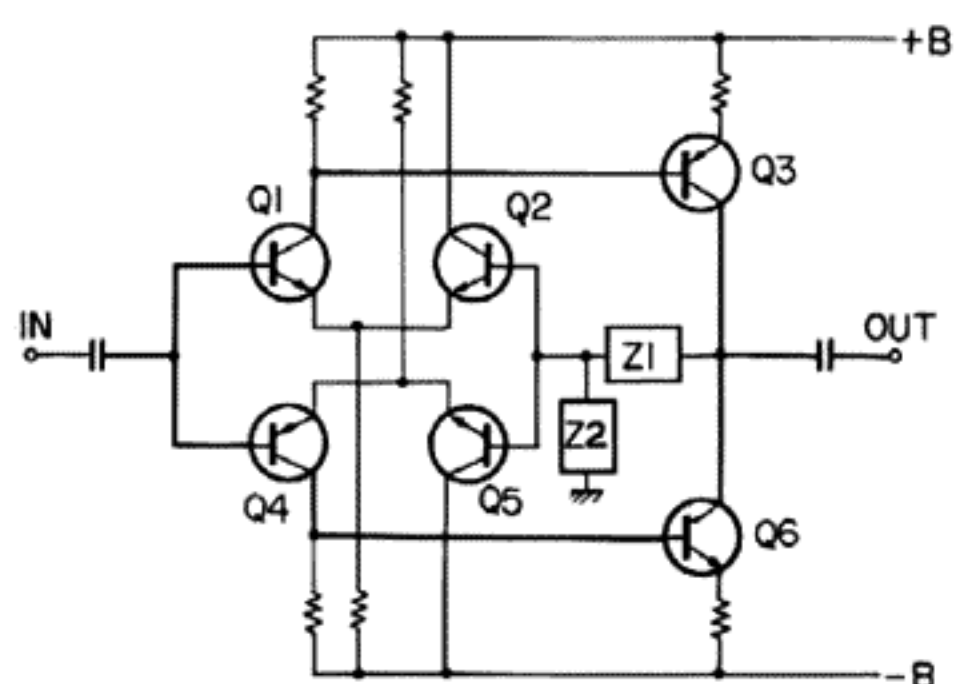

Fig. 1 BASIC CIRCUIT

2. EQUALIZER AMPLIFIER

The equalizer amplifier consists of the basic circuit shown in Fig. 1 to which connected are two stages of complementary—symmetry amplification. A high DC voltage of ± 60 V is applied to them to permit handling dynamic range inputs as large as 400mV with distortion confined to less than 0.1% at 1 kHz.

- a. ± 23 V is applied to the basic circuit section.
- b. Q11 and Q12 serve to stabilize the power source. This stage gains the above ± 23 V and increase the stability of the power source as well.
- c. D1, D2, D3 and D4 are heat compensating diodes that serve to stabilize the collector current in the output stage.
- d. The gain (40dB at 1kHz) and frequency response characteristics of this circuit are determined by the Negative Feedback (NF) Loop (Fig. 2). The tolerances of all main resistors and capacitors therein have been kept rigidly within $\pm 1\%$, permitting close adherence to the RIAA standard equalization curve within ± 0.2 dB from 20Hz to 20,000Hz.
- e. Subsonic vibrations of phono motors can cause inter modulation distortion and harm disc reproduction quality. The following circuit design has been adopted in this amplifier to prevent this.
 - * 6dB/oct attenuation is applied to all frequencies below 9Hz. This is achieved by the time constants of C1 and C7 in the Z2 section.
 - * In addition, a subsonic filter is built-in which permits cut-off of subsonic frequencies. (Switching C1 in or out by means of S3). The cut-off point of this filter is 25Hz.

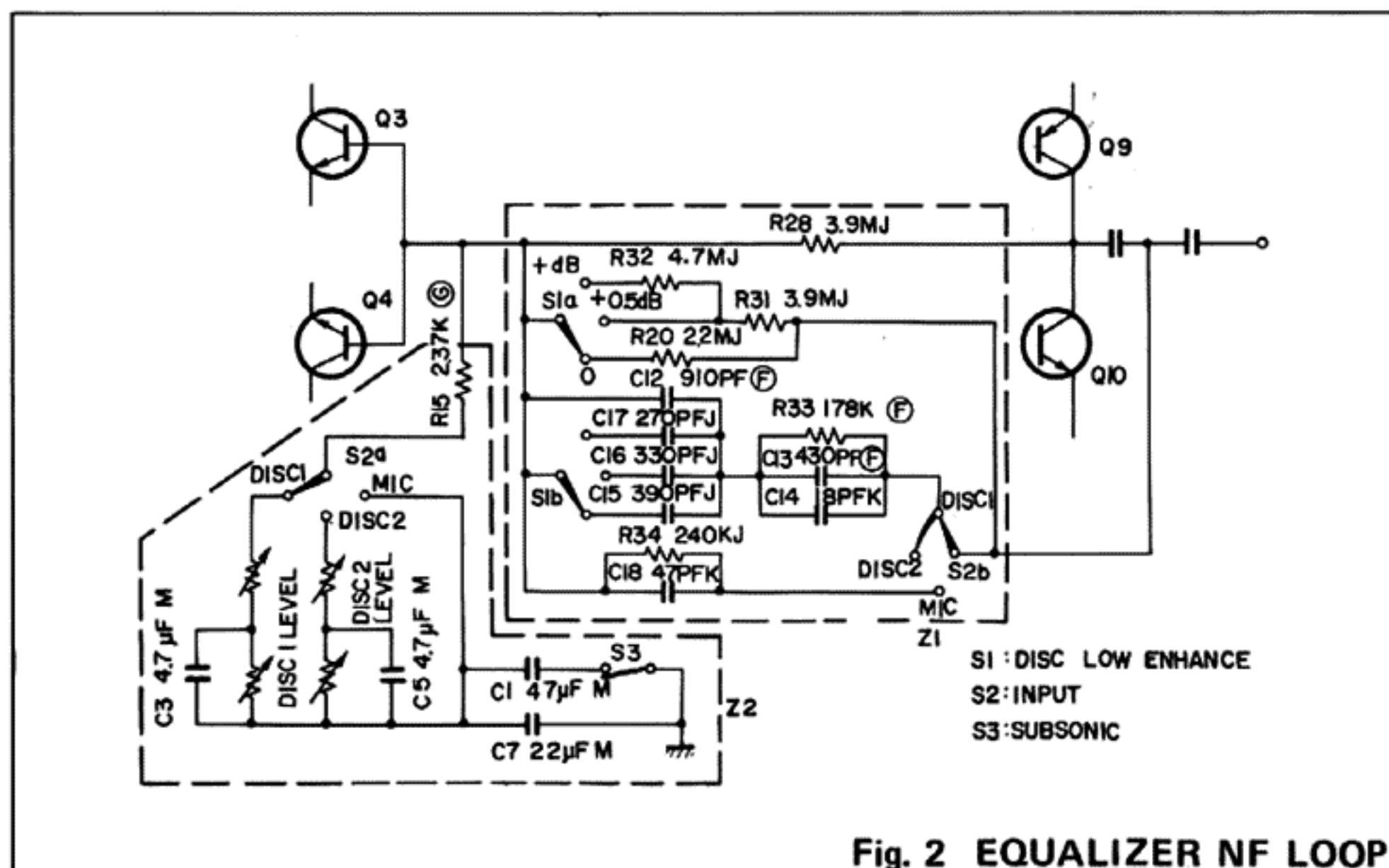

Fig. 2 EQUALIZER NF LOOP

3. TONE CONTROL CIRCUIT AND ITS SURROUNDINGS

The basic circuit in Fig. 1 is used. Tone control is achieved by varying Z_1 and Z_2 as previously pointed out.

a. DURING FLAT RESPONSE OR TONE CONTROL SWITCH AT OFF.

R_3 and R_4 of $10\text{ k}\Omega$ shown in the schematic diagram in page 19 and 20 constitute Z_1 and R_5 and R_6 of $1\text{ k}\Omega$, Z_2 . For reference sake the gain at this time is

$$\text{Gain} = 20 \log \frac{Z_1 + Z_2}{Z_2} = 20 \log \frac{11\text{K}\Omega}{1\text{K}\Omega} = 20 \text{ (dB)}$$

b. LOW BOOST

An abbreviated schematic for low boost circuit in the NF loop is shown in Fig. 3 (A). The low boost curve is obtained by changing the values of R_3 and C_1 by means of a rotary switch. R_3 here represents R_6 to R_{10} within the Bass control switch assembly No. 716-0001-00, and C_1 here represents C_{13} , and C_{20} to C_{24} . This applies only, however, when the TURN-OVER switch is at 400Hz. When this switch is at 200Hz, C_{14} to C_{17} are further connected into the circuit in parallel.

c. LOW CUT

Fig. 3 (B) briefly illustrates this low-cut circuit in the NF loop in which the low-cut curve is obtained by varying the values of R_4 and C_2 . As explained above, R_4 here represents R_1 to R_5 and C_2 here represents C_7 to C_{12} . With turnover at 200Hz, C_1 to C_6 are further connected into the circuit in parallel.

d. HIGH BOOST

Fig. 3 (C) shows the representative circuit in the NF loop for high boost, the curve for which is obtained by varying the values of R_5 and R_6 . R_5 and R_6 in this abbreviated schematic represents R_{17} , R_{19} , R_{21} , R_{23} , R_{25} , R_{27} , R_{37} , R_{39} , R_{41} , R_{43} , R_{45} and R_{47} .

Turnover is accomplished by fixing the C_3 value beforehand with 2 capacitors connected in parallel for 2.5kHz turnover, and one being cut off for 5kHz turnover. C_3 in this abbreviated schematic represents C_9 and C_{11} .

e. HIGH CUT

Fig. 3 (D) shows the representative circuit in the NF loop for high cut, the curve for which is obtained by varying the values of R_7 and R_8 . R_7 and R_8 in this abbreviated schematic represents R_{37} , R_{39} , R_{41} , R_{43} , R_{45} , and R_{47} . Turnover is accomplished by fixing the C_4 value beforehand with 2 capacitors connected in parallel for 2.5kHz turnover, and one being cut off for 5kHz turnover. C_4 in this abbreviated schematic represents C_{13} and C_{15} .

Note: $330\text{ k}\Omega$ or $470\text{ k}\Omega$ resistors are connected in parallel with some of the above capacitors in order to prevent click noises during switching.

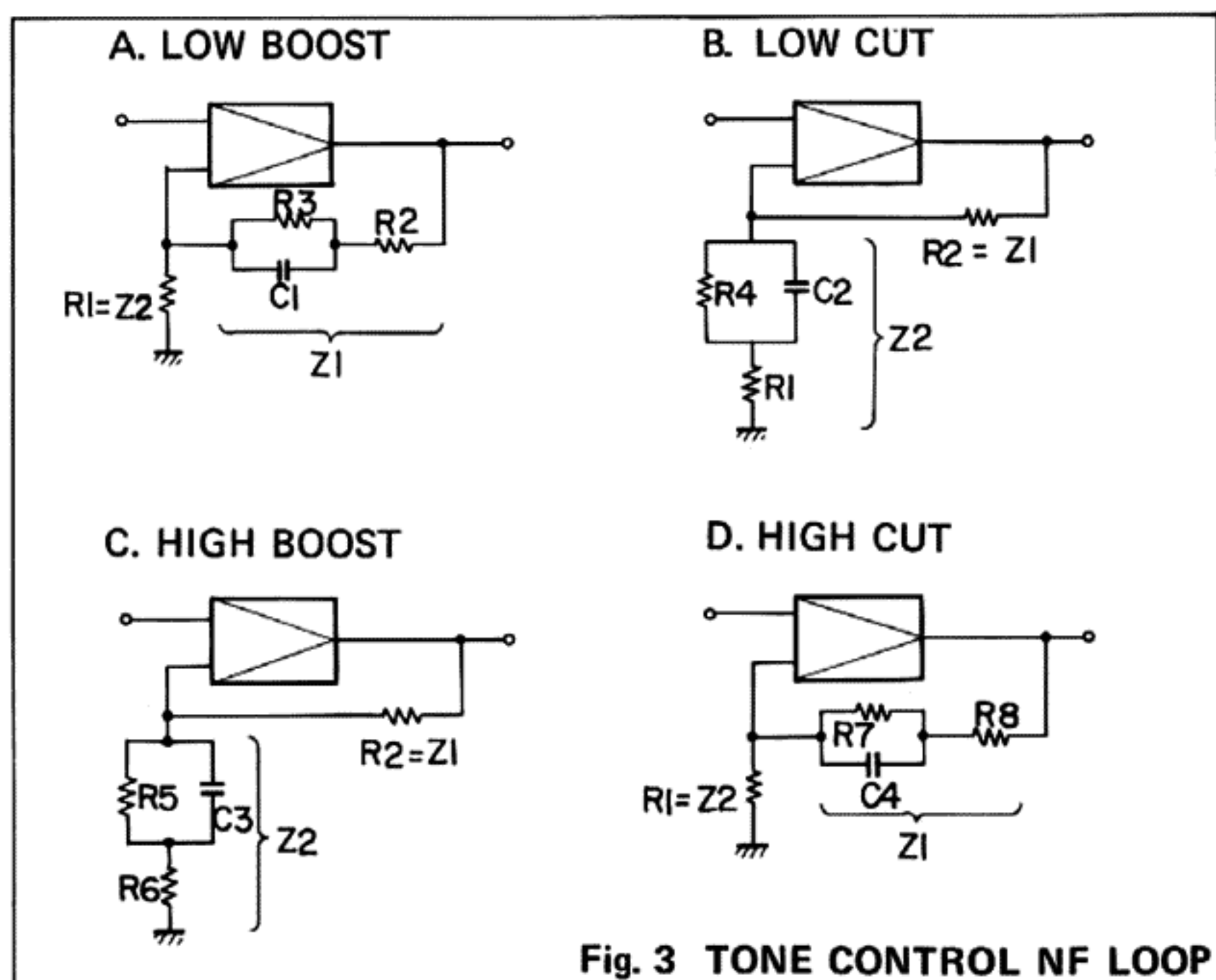

Fig. 3 TONE CONTROL NF LOOP

4. FILTER AND SURROUNDING CIRCUITS

a. FILTER CIRCUIT

Since gain is not necessary here, this circuit differs from the basic circuit and employs a complementary-symmetrical connection to incorporating, PNP and NPN type emitter follower circuits respectively. Low distortion and high stability are ensured through ingenious utilization of the mutual compensating characteristics. This circuit is by-passed when the filter is switched OFF.

b. OUTPUT CIRCUIT

This circuit also requires no gain and therefore employs an emitter follower a complementary-symmetrical connection, which further utilizes Darlington coupling to ensure a low output impedance.

5. HEADPHONE AMPLIFIER

The final stage in the basic circuit of this amplifier circuit is a real output amplifier, which employs a complementary symmetrical amplification equivalent to a main amplifier in every respect. Moreover, it is an output capacitor less type and possesses a damping factor of more than 50 against an 8 ohm load.

6. CONSTANT VOLTAGE POWER SUPPLY CIRCUIT

The positive side sets the standard for this dual power supply system with the negative side conforming to it. Therefore, plus and minus levels are always identical and cancel out pulse rise and fall values during ON-OFF switching and the consequent "shock" noise that otherwise would occur with switching. The output voltage of the high voltage side is 60 – 65V and that of the low voltage side is 30V, which is suppressed from the 60V. D-7, R7 and R9 determine the output voltage preciseness of the positive side, while R8 and R10 determine that of the negative side. These resistors therefore become natural check points when troubleshooting abnormal power supply voltages.

7. OTHER AUXILIARY CIRCUITS

a. PREVENTION RESIDUAL OUTPUT

Large capacity condensers are used in the power supply circuits. As a result, there is a lapse of time after power is turned OFF before these capacitors are fully discharged. This results in an undesirable residual output after AC is switched off.

To prevent this, this unit is equipped with a relay in the signal circuit which opens the circuit when power is turned off.

This reed relay is located on a printed-circuit board which is equipped with a push-button switch.

b. POWER SUPPLY PROTECTION

A Slow-Blow type fuse which is unaffected by initial "rush" currents is employed in the primary side of the power transformer. Since temporary current surges such as initial "rush" currents can cause ordinary type fuses to blow, it is general practice with such fuses to adopt a rating that is considerably higher than the normal current flow. This, of course, reduces the protective function of a fuse, so a slow-blow fuse has been employed in this amplifier to increase the safety factor.

On the other hand, a short circuit may occur in the power transformer secondary circuit (such as the pilot lamp circuit) which may not cause the fuse on the primary side to blow. Therefore, a fuse is also inserted in the secondary circuit to counteract this possibility and prevent the transformer from overheating. This fuse is mounted on a printed circuit board located in the chassis interior. Check this fuse in case of the following indications:

- * Indicator lamps fail to light although all other operations are normal.
- * Output is unavailable at the headphone jack only.
- * No output. No reed relay clicking, though very weak, sounds when the power switch is turned ON and OFF.

EQUALIZER AMP. ASSEMBLY (711-0001-00)

PRINTED CIRCUIT BOARD

*Printed circuit board as seen from the reverse side.

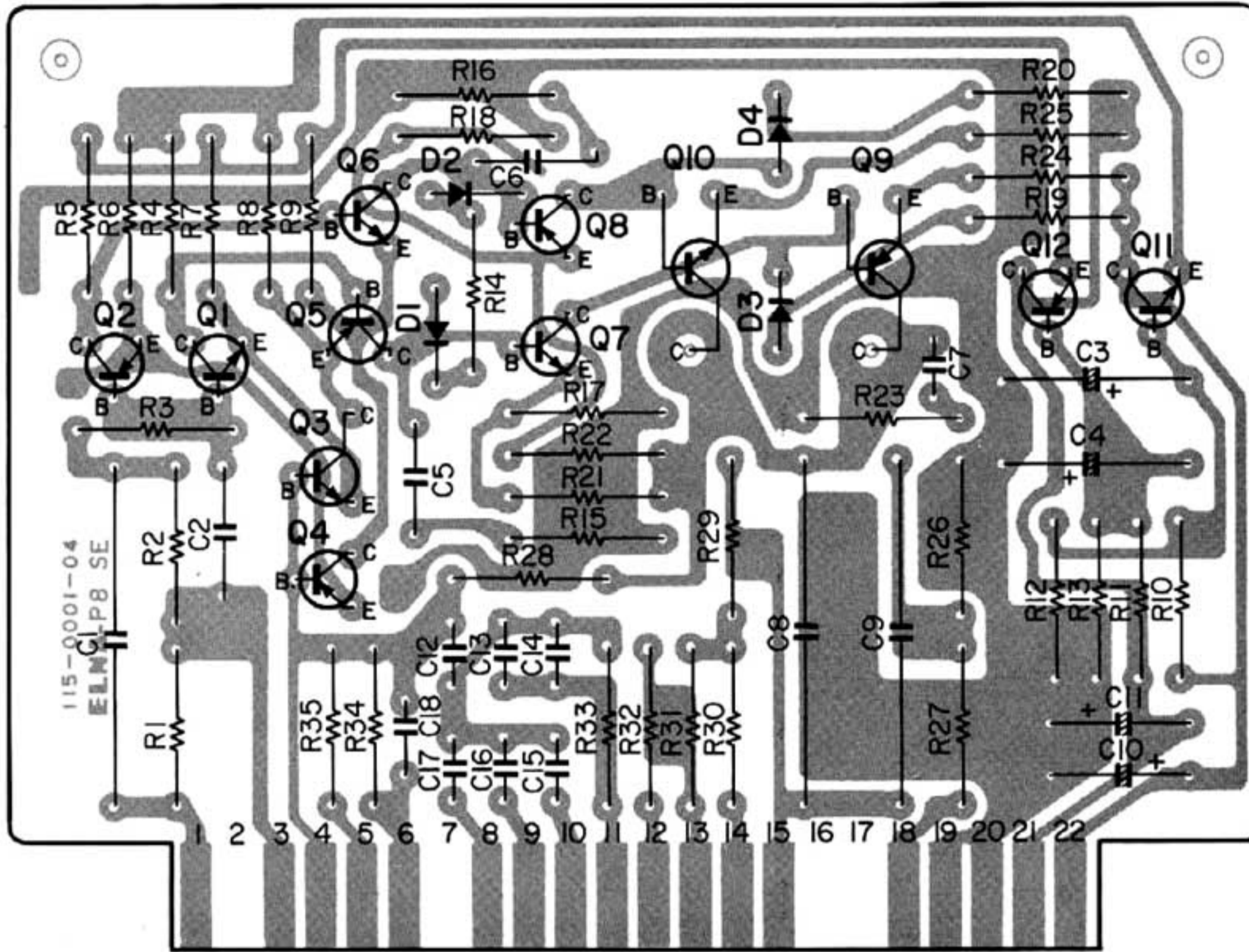

PARTS LIST

Ref. No.	Description	Part No.	Remarks
D3, 4	Silicon Diode	1S1555	
D1, 2	Silicon Varistor	SV-02	
Q2, 4, 5	Transistor PNP	2SA776A Y or GR	
Q1, 3, 6	Transistor NPN	2SC1416AGR	
Q8	Transistor PNP	2SA497R O or Y	
Q11	Transistor NPN	2SC1416GR	
Q9	Transistor PNP	2SA762-2-1 or 2-2	
Q10	Transistor NPN	2SC1431-2-1 or 2-2	
R24, 25	Carbon Film Resistor	120Ω ±5% 1/2W	RD142HA121J
R15, 16, 23	Carbon Film Resistor	180Ω ±5% 1/2W	RD142HA181J
R27	Carbon Film Resistor	200Ω ±5% 1/2W	RD142HA201J
R8, 9	Carbon Film Resistor	220Ω ±5% 1/2W	RD142HA221J
R19, 20	Carbon Film Resistor	330Ω ±5% 1/2W	RD142HA331J
R3	Carbon Film Resistor	1.8kΩ ±5% 1/2W	RD142HA182J
R17, 18	Carbon Film Resistor	2.2kΩ ±5% 1/2W	RD142HA222J
R35	Carbon Film Resistor	2.37kΩ ±2% 1/2W	RD142HA2371G
R14	Carbon Film Resistor	7.5kΩ ±5% 1/2W	RD142HA752J
R1	Carbon Film Resistor	130kΩ ±5% 1/2W	RD142HA134J
R12, 13, 21, 22	Carbon Film Resistor	82kΩ ±5% 1/2W	RD142HA823J
R10, 11	Carbon Film Resistor	120kΩ ±5% 1/2W	RD142HA124J
R33	Carbon Film Resistor	178kΩ ±1% 1/2W	RD142HA1783F
R34	Carbon Film Resistor	240kΩ ±5% 1/2W	RD142HA244J
R2	Carbon Film Resistor	430kΩ ±5% 1/2W	RD142HA434J
R26	Carbon Film Resistor	910kΩ ±5% 1/2W	RD142HA914J
R4, 5	Metal Film Resistor	47kΩ ±5% 1/2W	RN142HA473JO
R6, 7	Metal Film Resistor	330kΩ ±5% 1/2W	RN142HA334JO
R30	Metal Film Resistor	2.2MΩ ±5% 1/2W	RN142HA225JL
R28, 31	Metal Film Resistor	3.9MΩ ±5% 1/2W	RN142HA395JL
R29, 32	Metal Film Resistor	4.7MΩ ±5% 1/2W	RN142HA475JL
C3, 4	Electrolytic Capacitor	10μF 25WV	CE02W1E100
C10, 11	Electrolytic Capacitor	1μF 80WV	CE02W1K010
C14	Ceramic Capacitor	18pF ±10% 50WV	CC45SL1H180K
C18	Ceramic Capacitor	47pF ±10% 50WV	CC45SL1H470K
C17	Mica Capacitor	270pF ±5% 100WV	CM93D2A271J
C15	Mica Capacitor	390pF ±1% 100WV	CM93D2A391F
C16	Mica Capacitor	330pF ±5% 100WV	CM93D2A331J

Ref. No.	Description	Part No.	Remarks
C13	Mica Capacitor 430pF ±1% 100WV	CM93D2A431F	
C12	Mica Capacitor 910pF ±1% 100WV	CM93D2A911F	
C5, 6	Mica Capacitor 1500pF ±5% 100WV	CM93D2A152J	
C7	Mica Capacitor 1200pF ±5% 100WV	CM93D2A122F	
C1, 8, 9	Metallized Film Capacitor 2.2μF ±20% 250WV	CQ91M2E225M	
C2	Polystyrene Film Capacitor 22pF ±5% 125WV	CQ08S2B220J	
	Toothed Washer	639-2031-01	

FUSE CIRCUIT ASSEMBLY (716-0014-00)

PARTS LIST

Ref. No.	Description	Part No.	Remarks
F1~3	Fuse Holder	306-1001-00	
F4	Fuse	310-0101-00	1A
D1~5	Silicon Diode	310-0201-00	2A
C1, 2	Ceramic Capacitor	1BZ61	
C3, 4	Electrolytic Capacitor	CK45F1H103Z	0.01μF +80% -20% 50WV
C5	Electrolytic Capacitor	CE02W1V471	470μF 35W
		CE02W1E221	220μF 25WV

PUSH BUTTON SWITCH ASSEMBLY (716-0002-00)

PARTS LIST

Ref. No.	Description	Part No.	Remarks
SAB-232H	Pilot Lamp	176-4401-00	8V/150mA
	Push button Switch	354-9001-00	
	Reed Relay	363-1201-00	
R7, 8	Carbon Film Resistor 560Ω ±5% 1/2W	RD142HA561J	
R5, 6	Carbon Film Resistor 1kΩ ±1% 1/2W	RD142HA1001F	
R9, 10	Carbon Film Resistor 3.3kΩ ±5% 1/2W	RD142HA332J	
R3, 4	Carbon Film Resistor 10kΩ ±1% 1/2W	RD142HA1002F	
R1, 2	Carbon Film Resistor 16kΩ ±5% 1/2W	RD142HA163J	
C1, 2	Mylar Film Capacitor 0.033μF ±5% 50WV	CQ93M1H333J	

tone control assembly (712-0001-00)

PRINTED CIRCUIT BOARD

*Printed circuit board as seen from the reverse side.

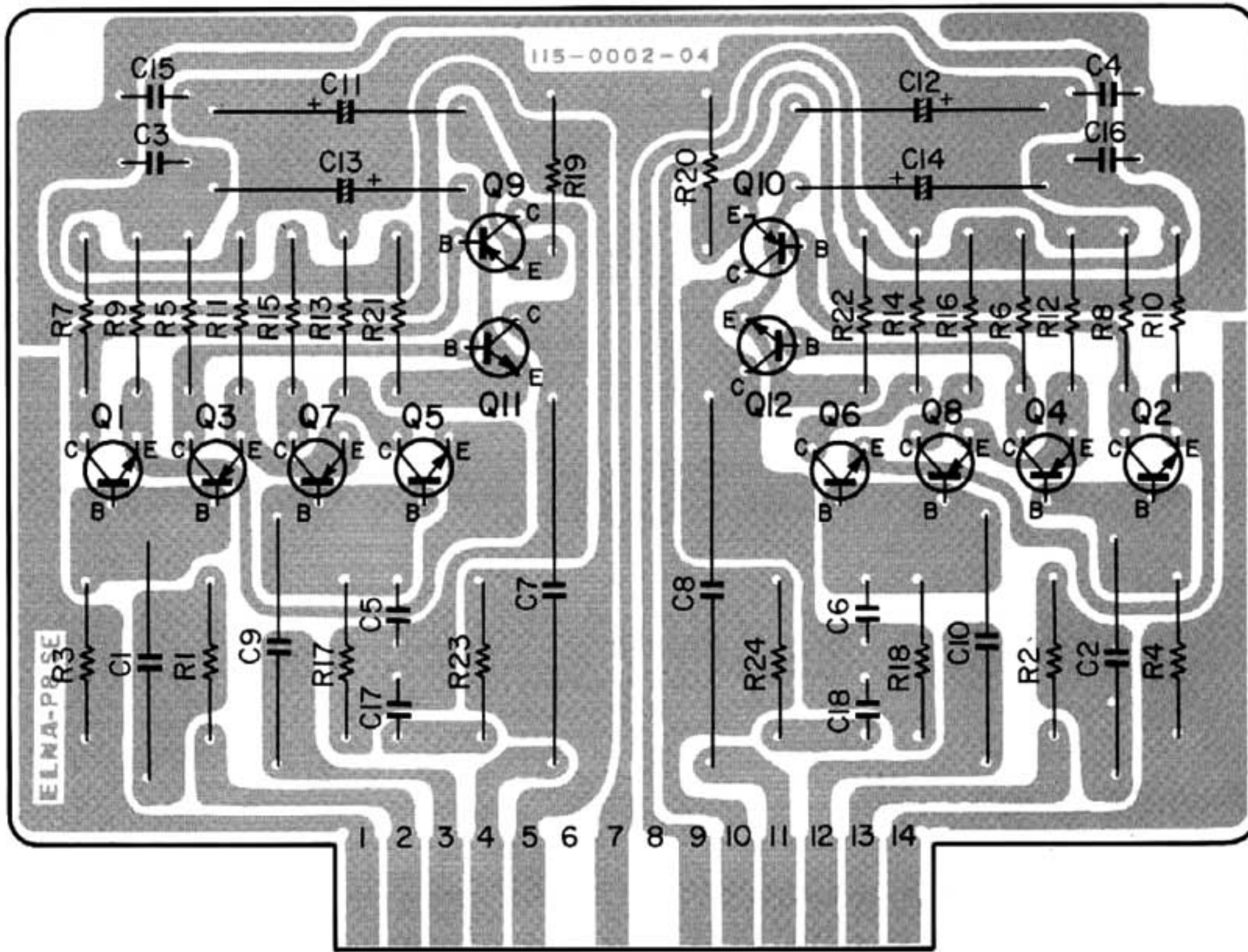

PARTS LIST

Ref. No.	Description	Part No.	Remarks
Q3, 4, 7, 8	Transistor PNP	2SA776A Y or GR	
Q1, 2, 5, 6	Transistor NPN	2SC1416A GR	
Q9, 10	Transistor PNP	2SA776GR	
Q11, 12	Transistor NPN	2SC1416GR	
R23, 24, 25, 26	Carbon Film Resistor 100Ω ±5% 1/2W	RD142HA101J	
R19, 20, 21, 22	Carbon Film Resistor 2.4kΩ ±5% 1/2W	RD142HA242J	
R1, 2	Carbon Film Resistor 390Ω ±5% 1/2W	RD142HA391J	
R13, 14, 15, 16	Carbon Film Resistor 7.5kΩ ±5% 1/2W	RD142HA752J	
R3, 4	Carbon Film Resistor 330kΩ ±5% 1/2W	RD142HA334J	
R17, 18	Carbon Film Resistor 910kΩ ±5% 1/2W	RD142HA914J	
R5, 6, 7, 8	Metal Film Resistor 82kΩ ±5% 1/2W	RN142HA823JO	
R9, 10, 11, 12	Metal Film Resistor 100kΩ ±5% 1/2W	RN142HA104JO	
C11, 12, 13, 14	Electrolytic Capacitor 220μF 10WV	CE02WA221	
C9, 10	Bipolar Electrolytic Capacitor 10μF 35WV	CE02D1V100(BP)	
C3, 4, 15, 16	Ceramic Capacitor 0.01μF +80%, -20% 50WV	CK45F1H103Z	
C7, 8	Metallized Film Capacitor 2.2μF ±20% 250WV	CQ91M2E225M	
C1, 2	Metallized Film Capacitor 1μF 250WV	CQ93M2E105M	
C5, 6	Mica Capacitor 20pF ±5% 100WV	CM93D2A200J	
C17, 18	Mica Capacitor 820pF ±5% 100WV	CM93D2A821J	

FILTER/OUTPUT ASSEMBLY (714-0001-00)

PRINTED CIRCUIT BOARD

*Printed circuit board as seen from the reverse side.

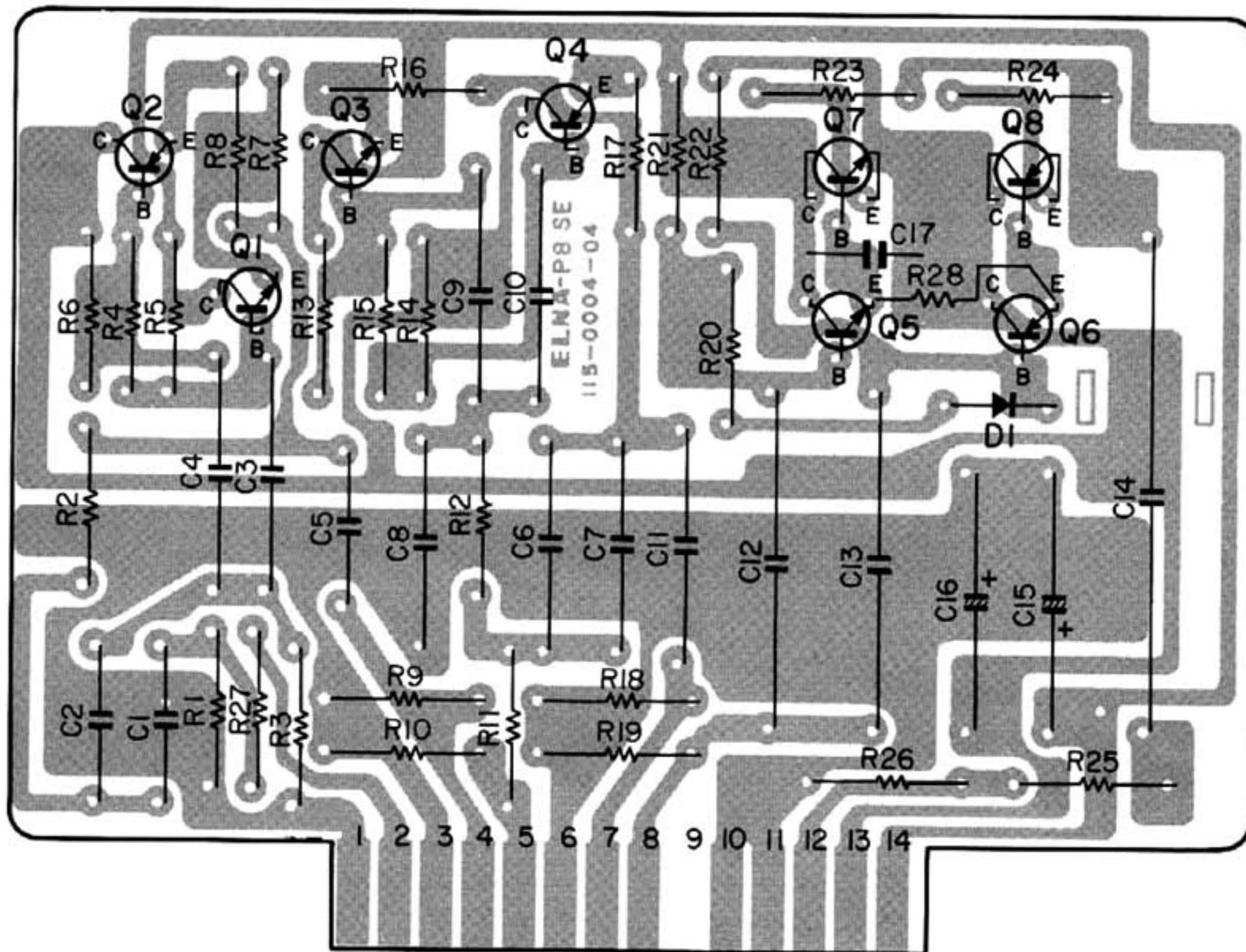

PARTS LIST

Ref. No.	Description	Part No.	Remarks
	Heatsink	240-2001-00	
	Spacer	250-0001-00	
Q8	Transistor PNP	2SA497R or O	
Q2, 4	Transistor PNP	2SA776Y or GR	
Q6	Transistor PNP	2SA776A GR	
Q7	Transistor NPN	2SC497R or O	
Q1, 3, 5	Transistor NPN	2SC1416GR	
D1	Silicon Varister	SV-02	
R23, 24	Carbon Film Resistor 91Ω ±5% 1/2W	RD142HA910J	
R25	Carbon Film Resistor 150Ω ±5% 1/2W	RD142HA151J	
R7, 8, 16, 17, 27	Carbon Film Resistor 220Ω ±5% 1/2W	RD142HA221J	
R11, 12	Carbon Film Resistor 8.2kΩ ±5% 1/2W	RD142HA822J	
R2	Carbon Film Resistor 13kΩ ±5% 1/2W	RD142HA133J	
R9	Carbon Film Resistor 39kΩ ±5% 1/2W	RD142HA393J	
R3	Carbon Film Resistor 51kΩ ±5% 1/2W	RD142HA513J	
R20	Carbon Film Resistor 62kΩ ±5% 1/2W	RD142HA623J	
R10	Carbon Film Resistor 240kΩ ±5% 1/2W	RD142HA244J	
R26	Carbon Film Resistor 470kΩ ±5% 1/2W	RD142HA474J	
R1, 18, 19	Carbon Film Resistor 910kΩ ±5% 1/2W	RD142HA914J	
R4, 15	Metal Film Capacitor 220kΩ ±5% 1/2W	RN142HA224JO	
R21, 22	Metal Film Capacitor 470kΩ ±5% 1/2W	RN142HA474JO	
R5, 6, 13, 14	Metal Film Capacitor 1.8MΩ ±5% 1/2W	RN142HA185JL	
C15, 16	Erectolytic Capacitor 47μF 35WV	CE02W1V470	
C1, 2, 5	Mylar Film Capacitor 0.22μF ±5% 50WV	CQ93M1H224J	
C8	Polystyrene Film Capacitor 2400pF ±5% 125WV	CQ08S2B242J	
C6, 7	Polystyrene Film Capacitor 3300pF ±5% 125WV	CQ08S2B332J	
C12, 13	Metallized Film Capacitor 0.47μF ±20% 250WV	CQ91M2E474M	
C14	Metallized Film Capacitor 4.7μF ±20% 250WV	CQ91M2E475M	
C3, 4, 9, 10, 11, 12, 13	Metallized Film Capacitor 0.47μF ±20% 250WV	CQ93M2E474M	
C17	Ceramic Capacitor 0.001μF +100%, -0% 500WV	CK45E2H102P	
R28	Carbon Film Resistor 4.7kΩ ±5% 1/2W	RD142H472J	

HEADPHONE AMP. ASSEMBLY (715-0001-00)

PRINTED CIRCUIT BOARD

*Printed circuit board as seen from the reverse side.

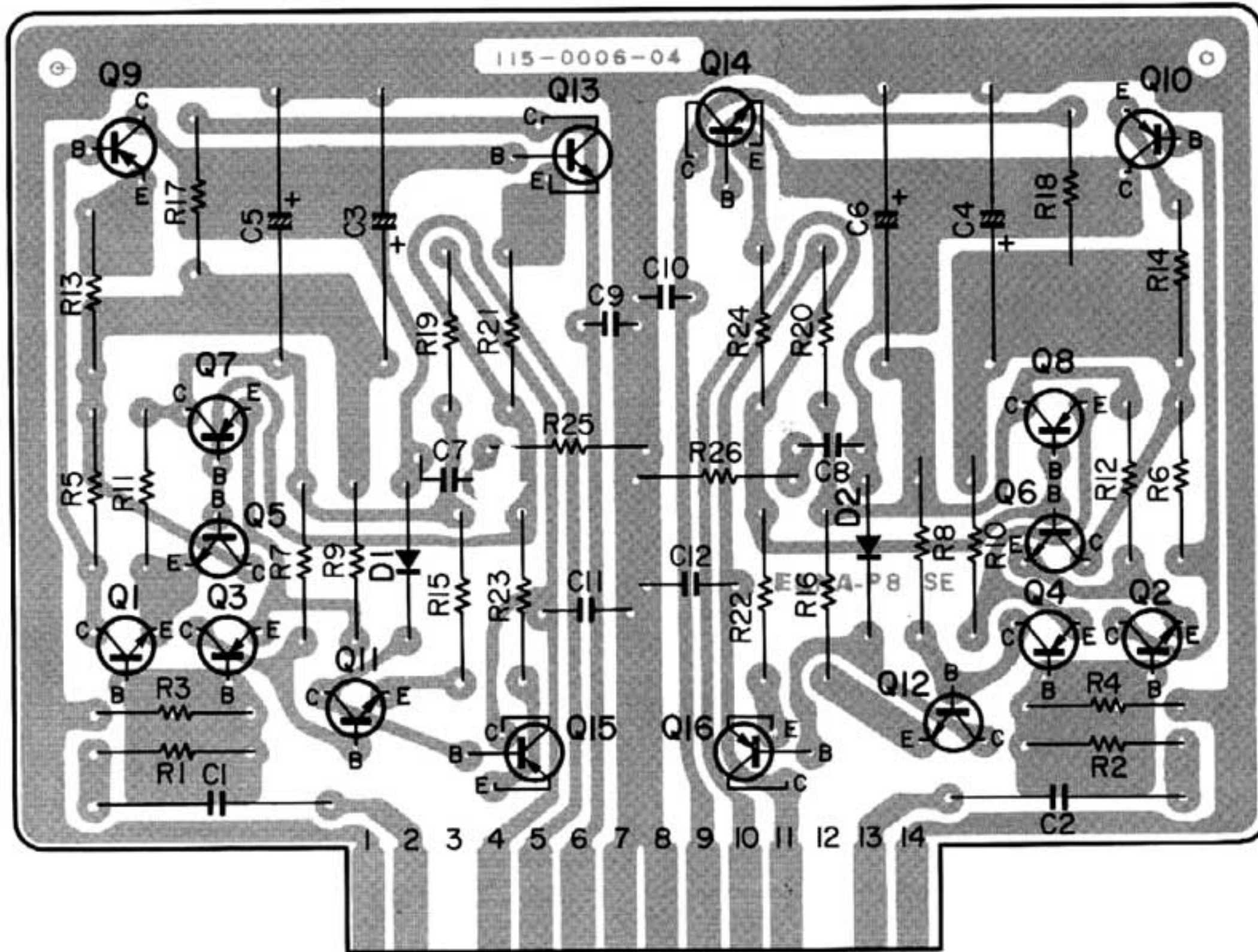

PARTS LIST

Ref. No.	Description	Part No.	Remarks
	Heatsink	240-2001-00	
	Spacer	250-0001-00	
Q15,16	Transistor PNP	2SA497R O or Y	
Q3,4,7,8,9,10	Transistor PNP	2SA776GR	
Q13,14	Transistor NPN	2SC497R O or Y	
Q1,2,5,6,11,12	Transistor NPN	2SC1416GR	
D1,2	Varistor	STV-3	
R25,26	Carbon Film Resistor 8.2Ω ±5% 1/2W	RD142HA802J	
R13,14,15,16	Carbon Film Resistor 33Ω ±5% 1/2W	RD142HA330J	
R17,18,19,20	Carbon Film Resistor 47Ω ±5% 1/2W	RD142HA470J	
R5,6,7,8	Carbon Film Resistor 4.7kΩ ±5% 1/2W	RD142HA472J	
R9,10,11,12	Carbon Film Resistor 8.2kΩ ±5% 1/2W	RD142HA822J	
R3,4	Carbon Film Resistor 10kΩ ±5% 1/2W	RD142HA103J	
R1,2	Carbon Film Resistor 43kΩ ±5% 1/2W	RD142HA433J	
R21,22,23,24	Metal Film Resistor 3.3Ω ±5% 1W	RN143AA3R3JX	
C3,4,5,6	Electrolytic Capacitor 470μF 6.3WV	CE02W0J471	
C1,2	Metallized Film Capacitor 1μF ±20% 250WV	CQ93M2E105M	
C9,10,11,12	Ceramic Capacitor 0.01μF +80% -20% 50WV	CK45F1H103Z	
C7,8	Metal Film Capacitor 1800PF ±5% 50WV	CQ93M1H182J	
C13,14	Polystyrene Film Capacitor 330pF ±5% 125WV	CQ08S2B331J	

POWER SUPPLY ASSEMBLY (719-0001-00)

PRINTED CIRCUIT BOARD

*Printed circuit board as seen from the reverse side.

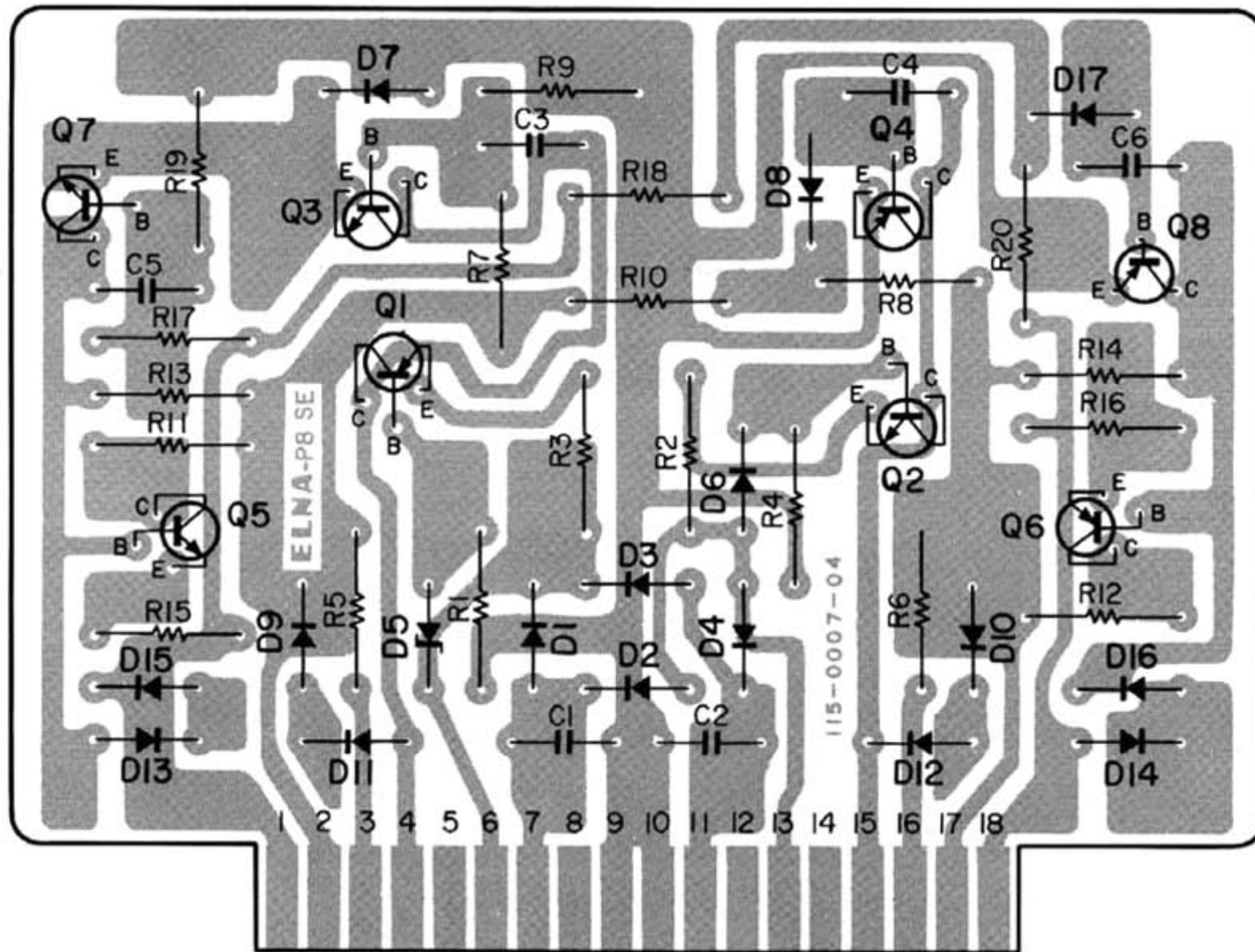

PARTS LIST

Ref. No.	Description	Part No.	Remarks
	Heatsink	240-2001-00	
	Spacer	250-0001-00	
Q1, 4	Transistor PNP	2SA497R, O or Y	
Q6	Transistor PNP	2SA497R O or Y	
Q8	Transistor PNP	2SA776GR	
Q2, 3	Transistor NPN	2SC497R, O or Y	
Q5	Transistor NPN	2SC497R O or Y	
Q7	Transistor NPN	2SC1416GR	
D8, 9, 10, 11	Silicon Diode	1S1555	
12, 13, 14, 15, 16, 17			
D1, 2, 3, 4	Silicon Diode	1GZ61	
D5, 6, 7	Zener Diode	XZ-162	
R15, 16	Carbon Film Resistor 10Ω ±5% 1/2W	RD142H100J	
R2, 3	Carbon Film Resistor 3.9kΩ ±5% 1/2W	RD142H392J	
R1, 4	Carbon Film Resistor 9.1kΩ ±5% 1/2W	RD142H912J	
R13, 14, 17	Carbon Film Resistor 27kΩ ±5% 1/2W	RD142H273J	
R9	Carbon Film Resistor 27.4kΩ ±2% 1/2W	RD142H2742G	
R19, 20	Carbon Film Resistor 33kΩ ±5% 1/2W	RD142H333J	
R18	Carbon Film Resistor 36kΩ ±5% 1/2W	RD142H363J	
R7, 8	Carbon Film Resistor 68.1kΩ ±2% 1/2W	RD142H6812G	
R10	Carbon Film Resistor 71.5kΩ ±2% 1/2W	RD142H7152G	
R5, 6	Metal Film Resistor 3.3Ω ±5% 1W	RN43AA3R3JX	
R11, 12	Oxide Metal Film Resistor		
	560Ω ±5% 2W	RS143DA561J	
C5, 6	Ceramic Capacitor 0.01μF +80%, -20% 50WV	CK45F1H103Z	
C1, 2, 3, 4	Ceramic Capacitor 0.01μF +100%, -0% 500WV	CK45F2H103P	
C7	Electrolytic Capacitor 33μF 25WV	CE02W1E330	

BASS CONTROL SWITCH ASSEMBLY (716-0001-00)

PARTS LIST

Ref. No.	Description	Part No.	Remarks
	Rotary Switch	336-1501-00	
R1	Carbon Film Resistor 510Ω ±5% 1/2W	RD142HA511J	
R2	Carbon Film Resistor 1.3kΩ ±5% 1/2W	RD142HA132J	
R3	Carbon Film Resistor 3kΩ ±5% 1/2W	RD142HA302J	
R10	Carbon Film Resistor 4.7kΩ ±5% 1/2W	RD142HA472J	
R4, 5	Carbon Film Resistor 8.2kΩ ±5% 1/2W	RD142HA822J	
R9	Carbon Film Resistor 13kΩ ±5% 1/2W	RD142HA133J	
R8	Carbon Film Resistor 30kΩ ±5% 1/2W	RD142HA303J	
R6	Carbon Film Resistor 43kΩ ±5% 1/2W	RD142HA433J	
R7	Carbon Film Resistor 91kΩ ±5% 1/2W	RD142HA913J	
R15, 16	Carbon Film Resistor 470kΩ ±5% 1/2W	RD142HA474J	
C20	Mylar Film Capacitor 0.015μF ±5% 50WV	CQ93M1H153J	
C21	Mylar Film Capacitor 0.039μF ±5% 50WV	CQ93M1H393J	
C13, 19, 24	Mylar Film Capacitor 0.047μF ±5% 50WV	CQ93M1H473J	
C11, 22	Tantalum Capacitor 0.1μF ±20% 35WV	CS15E1V0R1M	
C23	Tantalum Capacitor 0.22μF ±20% 35WV	CS15E1VR22M	
C10	Tantalum Capacitor 0.33μF ±20% 35WV	CS15E1VR33M	
C6, 8, 12	Tantalum Capacitor 0.47μF ±20% 35WV	CS15E1VR47M	
C9	Tantalum Capacitor 1μF ±20% 35WV	CS15E1V010M	
C7	Tantalum Capacitor 2.2μF ±20% 35WV	CS15E1V2R2M	

TREBLE CONTROL SWITCH ASSEMBLY (716-0013-00)

PARTS LIST

Ref. No.	Description	Part No.	Remarks
	Rotary Switch	336-1503-00	
R1, 2, 9, 10	Carbon Film Resistor	RD142HA334J	330kΩ ±5% ½W
R3	Carbon Film Resistor	RD142HA331J	330Ω ±5% ½W
R4	Carbon Film Resistor	RD142HA181J	180Ω ±5% ½W
R5	Carbon Film Resistor	RD142HA111J	110Ω ±5% ½W
R6	Carbon Film Resistor	RD142HA131J	130Ω ±5% ½W
R7	Carbon Film Resistor	RD142HA820J	82Ω ±5% ½W
R8	Carbon Film Resistor	RD142HA201J	200Ω ±5% ½W
R11	Carbon Film Resistor	RD142HA362J	3.6kΩ ±5% ½W
R12	Carbon Film Resistor	RD142HA162J	1.6kΩ ±5% ½W
R13	Carbon Film Resistor	RD142HA152J	1.5kΩ ±5% ½W
R14	Carbon Film Resistor	RD142HA122J	1.2kΩ ±5% ½W
R15	Carbon Film Resistor	RD142HA102J	1kΩ ±5% ½W
R16	Carbon Film Resistor	RD142HA112J	1.1kΩ ±5% ½W
C1, 2	Mylar Film Capacitor	CQ93M1H393J	0.039μF ±5% 50WV
C3, 4	Mylar Film Capacitor	CQ93M1H332J	3300pF ±5% 50WV

RESISTOR COLOR CODE

4 COLOR CODE RESISTOR

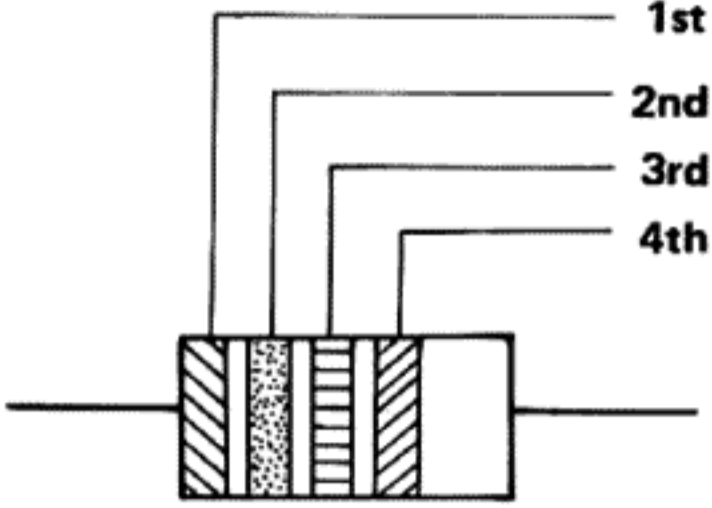
COLOR (Meaning)	1st (Value)	2nd (Value)	3rd (Multiplier)	4th (Tolerance)	Remarks
Black	0	0	10^0		
Brown	1	1	10^1	$\pm 1\%$	
Red	2	2	10^2	$\pm 2\%$	
Orange	3	3	10^3		
Yellow	4	4	10^4		
Green	5	5	10^5		
Blue	6	6	10^6		
Purple	7	7	10^7		
Grey	8	8	10^8		
White	9	9	10^9		
Gold	—	—	10^{-1}	$\pm 5\%$	
Silver	—	—	10^{-2}	$\pm 10\%$	
Non-Color	—	—	—	$\pm 20\%$	

5 COLOR CODE RESISTOR

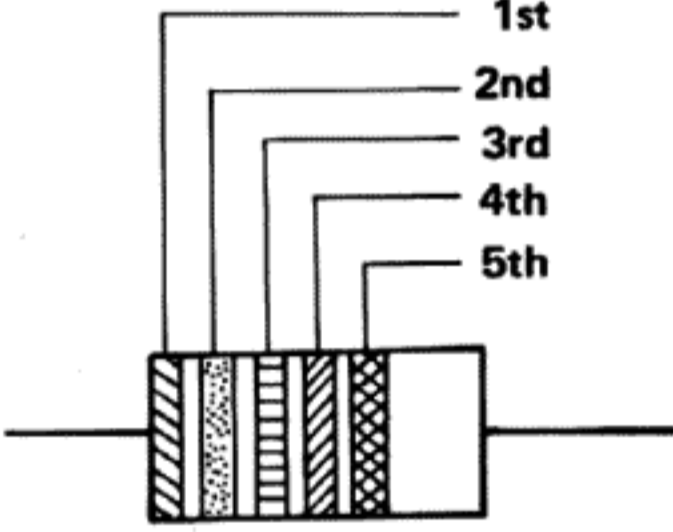
COLOR (Meaning)	1st (Value)	2nd (Value)	3rd (Value)	4th (Multiplier)	5th (Tolerance)	Remarks
Black	0	0	0	10^0		
Brown	1	1	1	10^1	$\pm 1\%$	
Red	2	2	2	10^2	$\pm 2\%$	
Orange	3	3	3	10^3		
Yellow	4	4	4	10^4		
Green	5	5	5	10^5		
Blue	6	6	6	10^6		
Purple	7	7	7	10^7		
Grey	8	8	8	10^8		
White	9	9	9	10^9		
Gold	—	—	—	10^{-1}	$\pm 5\%$	
Silver	—	—	—	10^{-2}	$\pm 10\%$	
Non-Color	—	—	—	—	$\pm 20\%$	

EXAMPLE

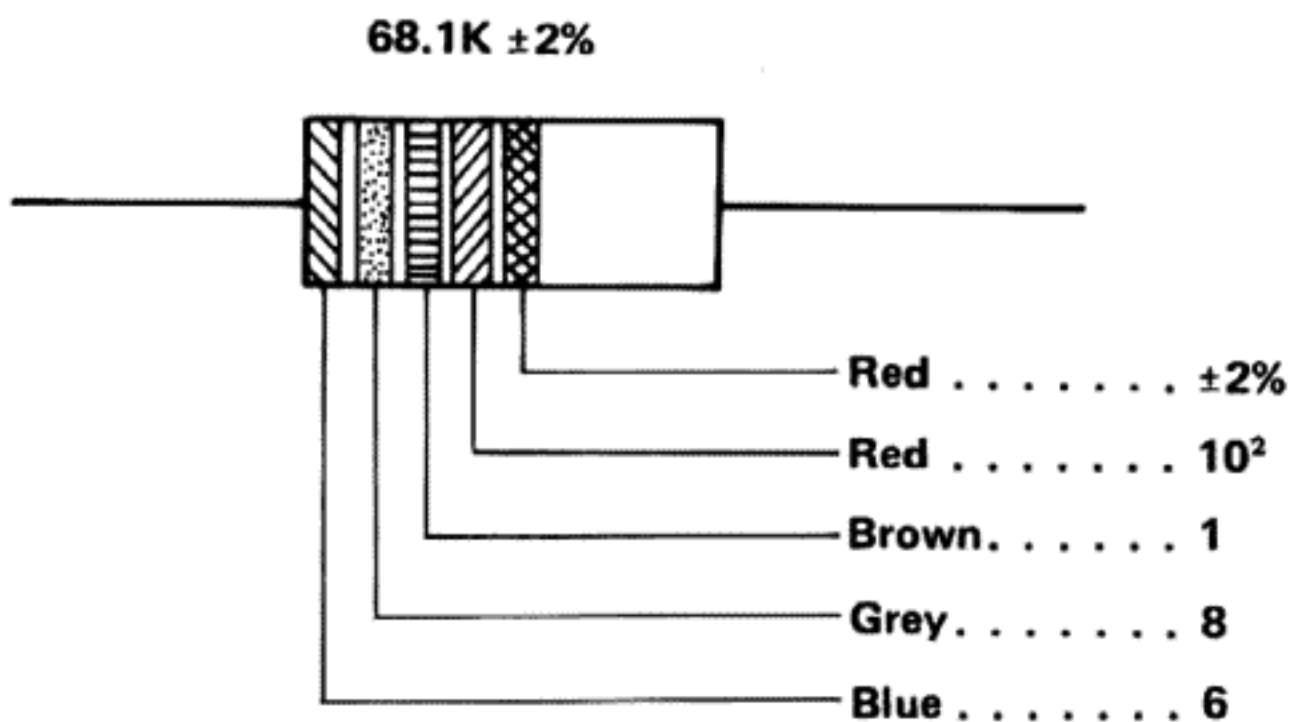

TRANSISTOR LEADS

FILTER/OUTPUT ASSEMBLY

REF. NO.	DESCRIPTION	PICTURE 1
Q1, 3, 5	2SC1416 GR	A
Q2, 4	2SA776 Y or GR	A
Q6	2SA776A GR	A
Q7	2SC497 R or O	B
Q8	2SA497 R or O	B

tone CONTROL ASSEMBLY

REF. NO.	DESCRIPTION	PICTURE 1
Q1, 2, 5, 6	2SC1416A GR	A
Q3, 4, 7, 8	2SA776A Y or GR	A
Q9, 10	2SA776 Y or GR	A
Q11, 12	2SC1416 GR	A

EQUALIZER AMP. ASSEMBLY

REF. NO.	DESCRIPTION	PICTURE 1
Q1, 3, 6	2SC1416A GR	A
Q2, 4, 5	2SA776A Y or GR	A
Q7	2SC497 R or Y	B
Q8	2SA497 R or Y	B
Q9	2SA762 2-1 or 2-1 or 2	C
Q10	2SC1431 2-1 or 2-1 or 2	C
Q11	2SC1416 GR	A
Q12	2SA776 GR	A

HEADPHONE AMP. ASSEMBLY

REF. NO.	DESCRIPTION	PICTURE 1
Q1,2,5,6,11,12	2SC1416 GR	A
Q3,4,7,8,9,10	2SA776 GR	A
Q13, 14	2SC497 R.O or Y	B
Q15, 16	2SA497 R.O or Y	B

FUSE CIRCUIT ASSEMBLY

REF. NO.	DESCRIPTION	PICTURE 1
Q1, 2	2SC1416 GR or BL	A

POWER SUPPLY ASSEMBLY

REF. NO.	DESCRIPTION	PICTURE 1
Q1, 4	2SA484 Y or BL	B
Q2, 3	2SC484 Y or BL	B
Q5	2SC497 R.O or Y	B
Q6	2SA497 R.O or Y	B
Q7	2SC1416 GR	A
Q8	2SA776 GR	A

MAIN CHASSIS

REF. NO.	DESCRIPTION	PICTURE 1
Q1	2SA483 R	C
Q2	2SC783 R	C

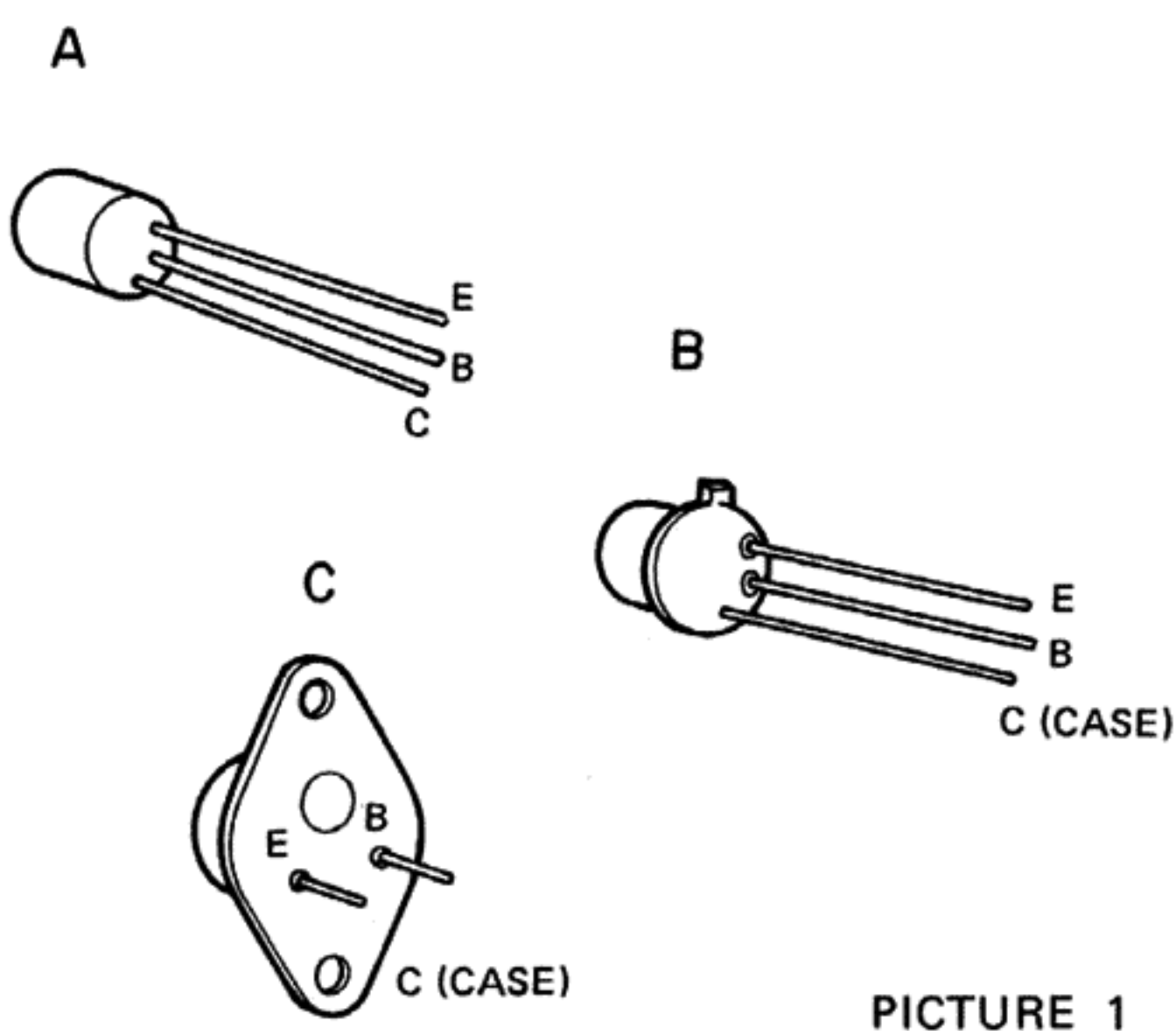

PICTURE 1

Use of transistors other than specified will adversely affect performance and should be avoided.

THE MARK OF CAPACITOR AND RESISTORS ON THE SCHEMATIC DIAGRAM

- | | |
|--------------------------------|--|
| ○: CERAMIC CAPACITORS | □: METAL FILM RESISTORS |
| ⊖: MICA CAPACITORS | ■: OXED METAL FILM RESISTORS |
| ⊗: TANTALUM SOLID CAPACITORS | ⊠: CEMENT COATED WIRE WOUND RESISTORS |
| ●: METALLIZED FILM CAPACITOR | ▣: CEMENT COATED METAL PLATE RESISTORS |
| ⊕: POLYSTYRENE FILM CAPACITORS | |
| ⊙: MYLAR FILM CAPACITORS | |
- Unless other wise specified: Capacitors are ELECTROLYTIC Types: Resistors are CARBON FILM Types, 1/2 watt, and ±5% tolerance;

Indicated values of parts in the schematic diagram may be changed in case of performance improvement.

C-200 REVISED SCHEMATIC DIAGRAM

This is the new Schematic Diagram as of July, 1976.
Please note that it includes slight changes from the Printed Board pattern and Parts List which appear in the foregoing pages.

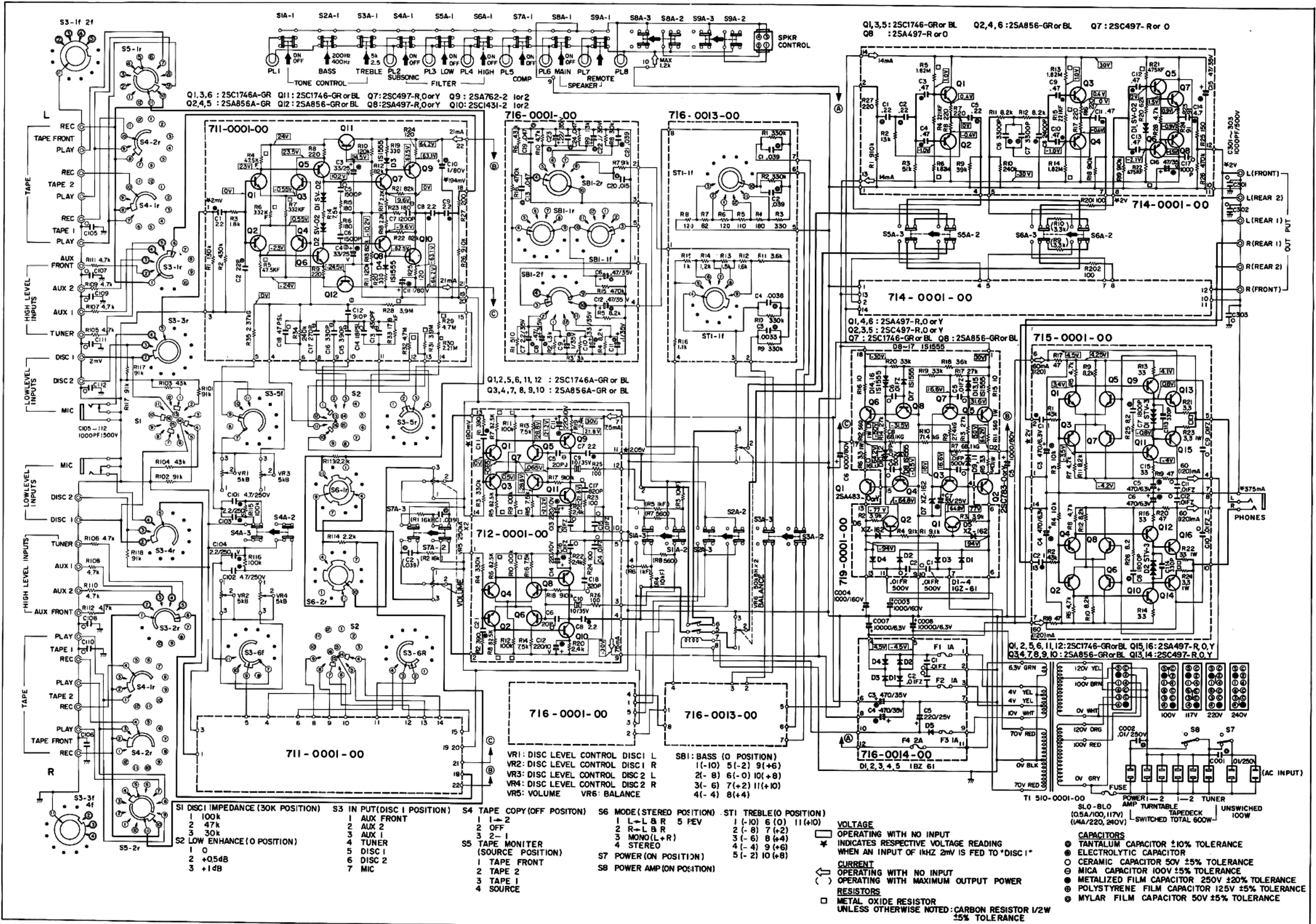

C-200 REVISED SCHEMATIC DIAGRAM

This is t
Please r

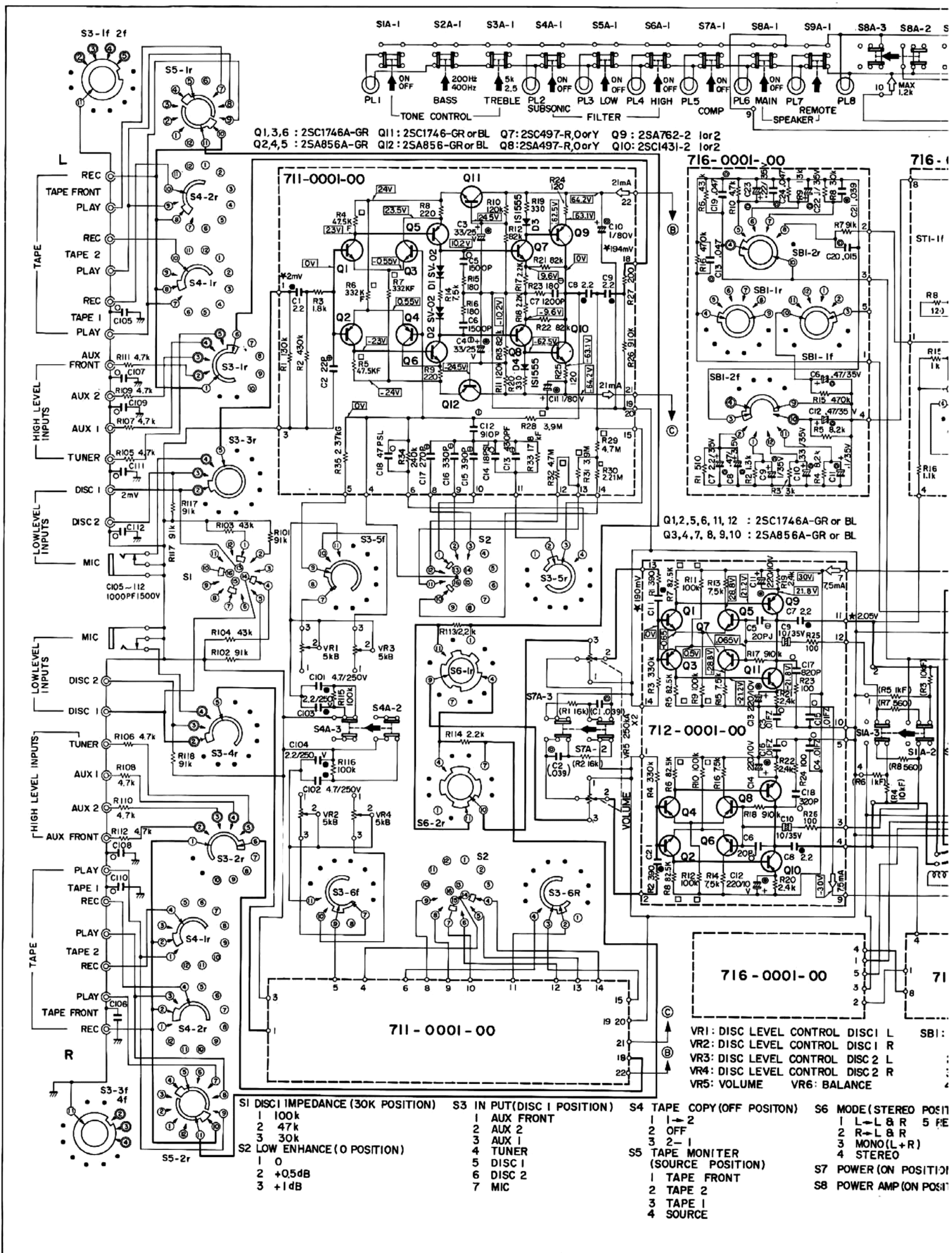

This is the new Schematic Diagram as of July, 1976.

Please note that it includes slight changes from the Printed Board pattern and Parts List which appear in the foregoing pages.

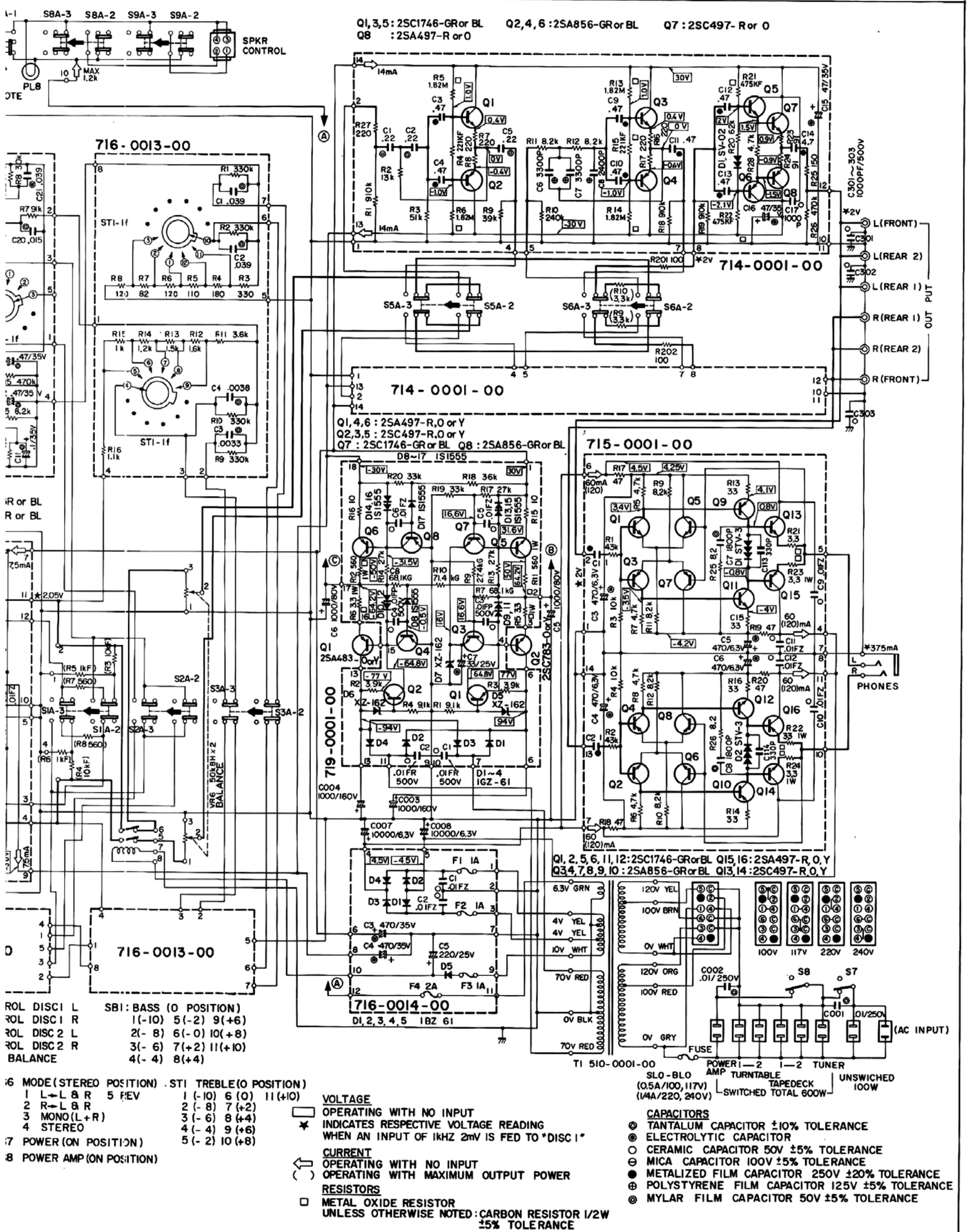

SPECIFICATIONS

PERFORMANCE GUARANTY:

Products of Kenosonic guarantee specifications stated.

FREQUENCY RESPONSE:

High level input: +0, — 0.2 dB 20 Hz to 20,000 Hz
Low level input: +0.2 — 0.2 dB 20 Hz to 20,000 Hz

DISTORTION:

Lower than 0.05% at rated output level, 20 Hz to 20,000 Hz.

INPUT SENSITIVITY AND IMPEDANCE:

Disc 1	2 — 6 mV*	20 K ohms, 30 K ohms, 47 K ohms.
Disc 2	2 — 6 mV*	47 K ohms.
Mic	2 mV	47 K ohms.
Tuner	200 mV	130 K ohms.
Aux 1, 2, FRONT	200 mV	130 K ohms.
Tape Play 1, 2, FRONT	200 mV	130 K ohms.

(* 2—6 mV changeable)

MAXIMUM INPUT FOR DISC INPUT:

400 mVrms at level control maximum (equalizer gain 40 dB) for 1 kHz.
1.2 Vrms, at level control minimum (equalizer gain 30 dB) for 1 kHz.
at 1 kHz 0.05% distortion

OUTPUT LEVEL AND IMPEDANCE:

Main Output	2.0 V*	200 ohms.
Headphones	0.4 V*	0.3 ohms.
Tape Rec. 1, 2, FRONT	200 mV	200 ohms.

(* at rated input, volume control maximum)

MAXIMUM OUTPUT LEVEL:

10 Volts at 0.05% distortion.

VOLTAGE AMPLIFICATION IN DECIBELS:

Tuner, Aux, Tape Play input:

to Main Output	20 dB.
to Tape Rec.	0 dB.
to Headphones	6 dB.

Disc 1, Disc 2, and Mic Input (at 1 kHz):

to Main Output	60 dB.
to Tape Rec.	40 dB.
to Headphones	46 dB.

HUM AND NOISE:

Tuner, Aux, Tape Play: 90 dB below rated output.
Disc, Mic: 74 dB below 10 mV input, 64 dB below rated input.

TONE CONTROLS:

11 Position Rotary Switch for each channel with turnover frequency switches.

BASS:

Turnover frequency 400 Hz: ±10 dB (2 dB step) at 100 Hz.
Turnover frequency 200 Hz: ±10 dB (2 dB step) at 50 Hz.

TREBLE:

Turnover frequency 2,500 Hz: ±10 dB (2 dB step) at 10,000 Hz.
Turnover frequency 5,000 Hz: ±10 dB (2 dB step) at 20,000 Hz.

DISC LOW ENHANCEMENT (for Disc input):

0 dB, +0.5 dB, +1 dB at 100 Hz to RIAA standard characteristics.
Bass tone becomes richer and more natural when switched to +0.5 dB or +1 dB.

COMPENSATOR:

ON position boosts low frequencies for low level listening.
+9 dB at 50 Hz (at volume control —30 dB)

FILTERS:

Disc Subsonic Filter:	25 Hz cutoff	6 dB/oct.
Low Filter:	30 Hz cutoff	18 dB/oct.
High Filter:	5,000 Hz cutoff	12 dB/oct.

VOLUME CONTROL:

Less than ±1 dB tracking error control at all listening levels.

POWER REQUIREMENT:

Voltage selector for 100V, 117V, 220V, 240V 50/60 Hz operation.
Consumption: 36 Watts.

SEMICONDUCTOR COMPLEMENT:

80 Transistors, 35 Diodes.

DIMENSIONS:

17½ inches (445 mm) wide, by 6 inches (152 mm) high, 14 inches (355 mm) deep.

WEIGHT:

30.8 pounds (14 kgr.) net, 40.6 pounds (18.3 kgr.) in shipping carton.



KENSONIC LABORATORY INC.
2124-6 MOTOISHOKAWA-CHO,
MIDORIKU, YOKOHAMA, JAPAN