

Accuphase Service Information

STARTING WITH SERIAL No. D9Y001

Authorized Technical Service Only

サービス資格のある技術者が使用して下さい



Power Amplifier A-65

A-65 Schematic Diagram / 回路図

CAUTION / 注意

These servicing instructions are for use by qualified personnel only. To reduce the risk of electric shock do not perform any servicing other than that contained in the operating instructions unless you are qualified to do so. Refer all servicing to qualified service personnel.

ここに記載したサービスに関する指示事項は、サービスに関する資格を有する者のみが使用するものです。感電防止の観点から、サービス資格を有していない方は、取扱指示事項以外のサービスは絶対に行わないようにして下さい。

⚠ Attention mark indicating critical components for safety. Replacement must be made with identical parts of special part number. このマークのついている部品は、安全上重要な部品です。必ず指定されている部品番号の部品を使用して下さい。

EXPLANATION OF SURFACE PARTS

(外観部品)

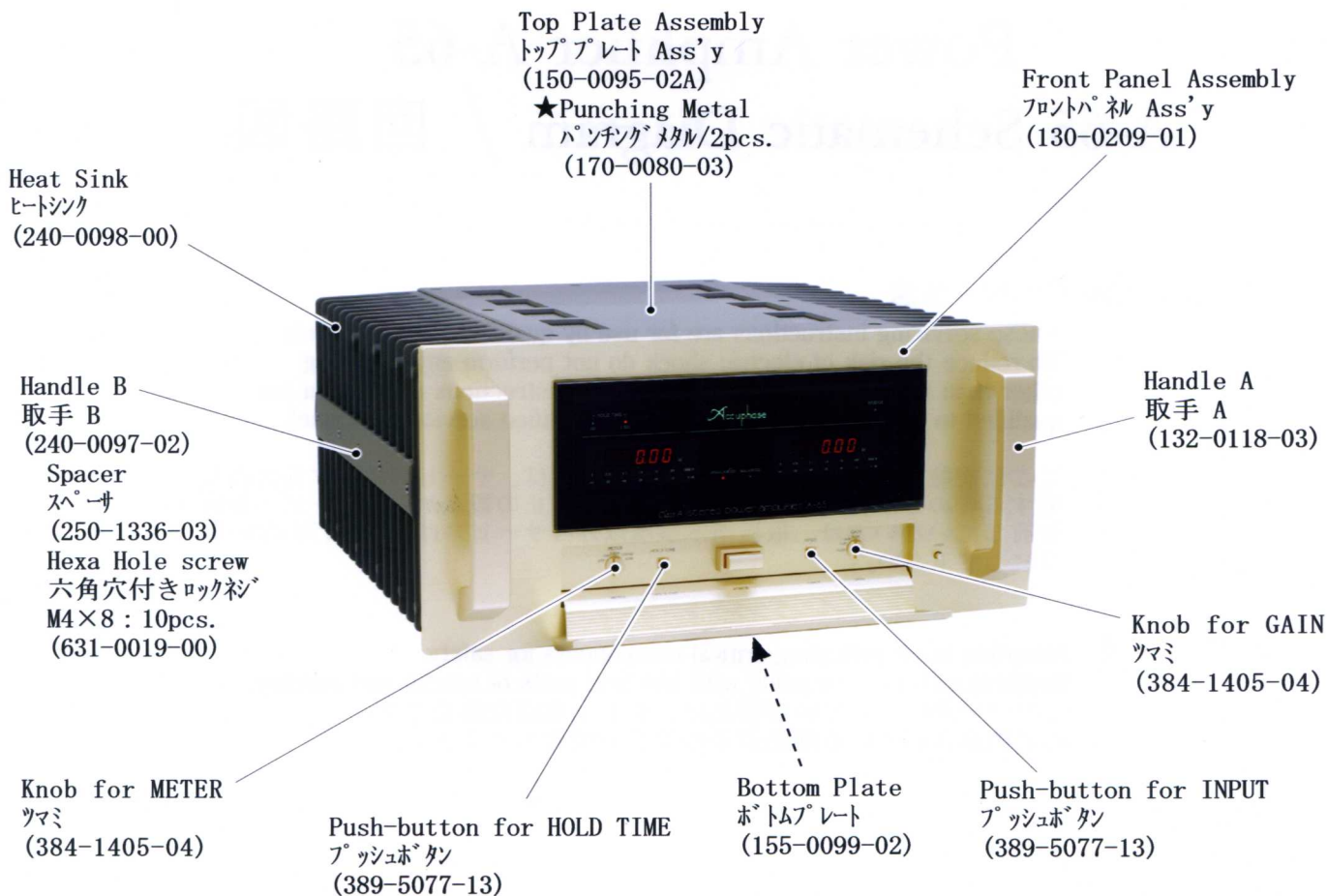
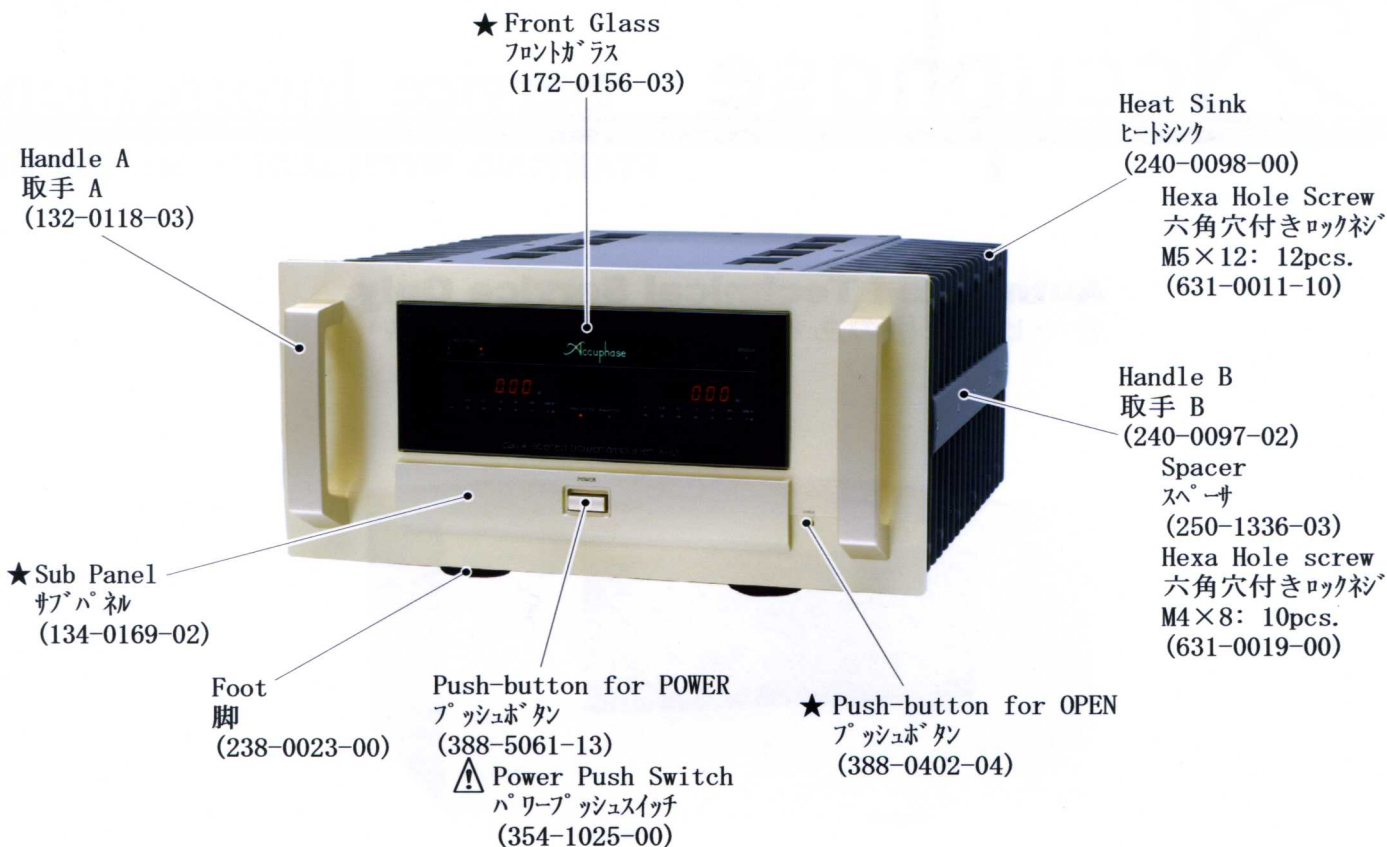

★ mark parts not supplied

マーク部品は供給出来ません

FRONT VIEW (前面)

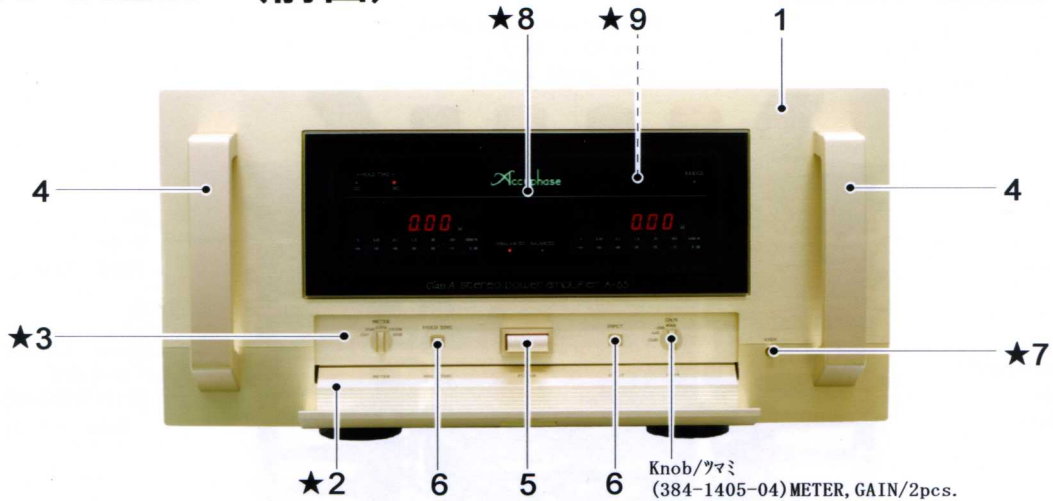

Front Panel Assembly
フロントパネル Ass'y
(130-0209-01)

- | | | | |
|--|-------|---|-------|
| 1. Front Panel=131-0209-01
フロントパネル | 1pce. | 6-1. Push-button Frame=113-0111-14
プッシュボタンフレーム | 2pcs. |
| 2. Sub-panel=134-0169-02
サブパネル | 1pce. | 6-2. Coil Spring=285-1023-04
コイルスプリング | 2pcs. |
| 3. Panel Name Plate=180-1108-03
パネルネームプレート | 1pce. | 7. Push-button=388-0402-04
プッシュボタン /OPEN | 1pce. |
| 4. Handle=132-0118-03
取手A | 2pcs. | 7-1. Coil Spring=285-1022-04
コイルスプリング | 1pce. |
| 5. Push-button=388-5061-13
プッシュボタン /POWER | 1pce. | 7-2. Washer=637-0043-04
ワッシャー | 1pce. |
| 5-1. Push-button Frame=113-0143-04
プッシュボタンフレーム | 1pce. | 7-3. E-ring=647-1055-00
E-リング | 1pce. |
| 5-2. Coil Spring=285-1022-04
コイルスプリング | 1pce. | 8. Front Glass=172-0156-03
フロントガラス | 1pce. |
| 5-3. Washer=637-0043-04
ワッシャー | 1pce. | 9. Indicator=173-9105-03
インディケータ | 1pce. |
| 5-4. E-ring=647-1055-00
E-リング | 1pce. | | |
| 6. Push-button=389-5077-13
プッシュボタン /HOLD TIME/INPUT | 2pcs. | | |
| 5-1. Retainer=283-1028-04
軸受 | | | |

Knob/ツマミ
(384-1405-04)METER, GAIN/2pcs.

REAR VIEW (後面)

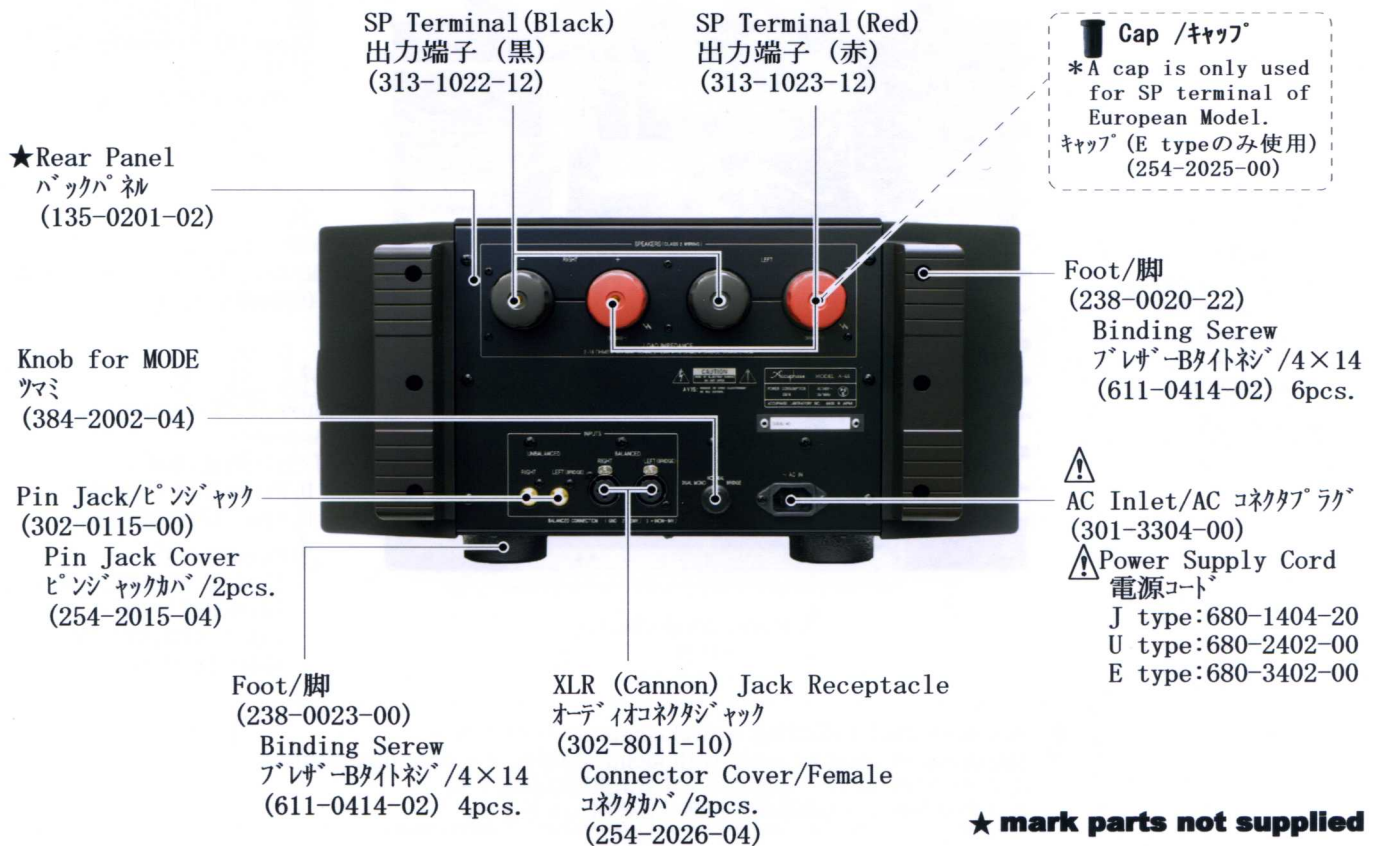

Cap /キャップ
*A cap is only used for SP terminal of European Model.
キャップ (E typeのみ使用)
(254-2025-00)

★ mark parts not supplied
マーク部品は供給出来ません

TOP VIEW (上面)

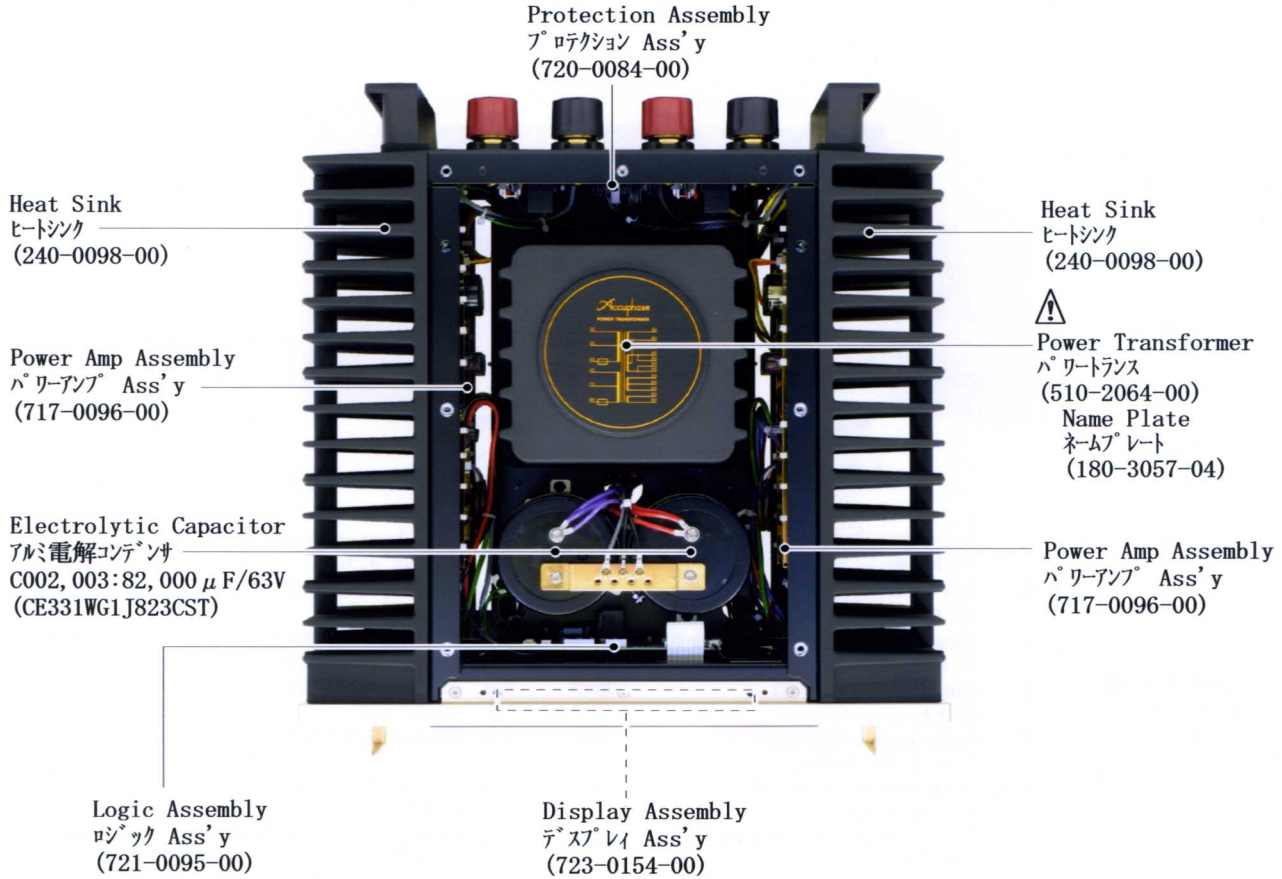

BOTTOM VIEW (底面)

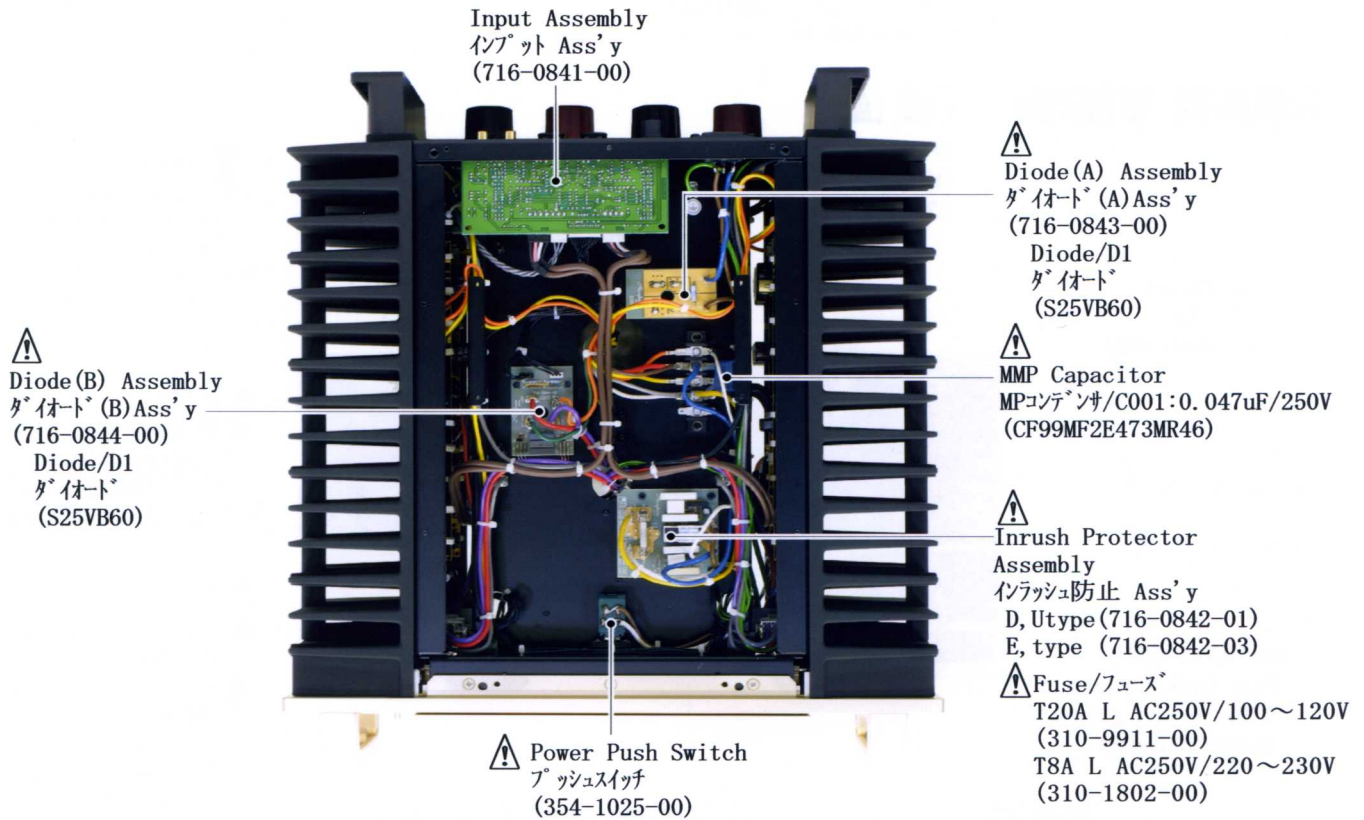

⚠ Attention mark indicating critical components for safety. Replacement must be made with identical parts of special part number.
 このマークのついている部品は、安全上重要な部品です。
 必ず指定されている部品番号の部品を使用して下さい。

FRONT VIEW (前面)

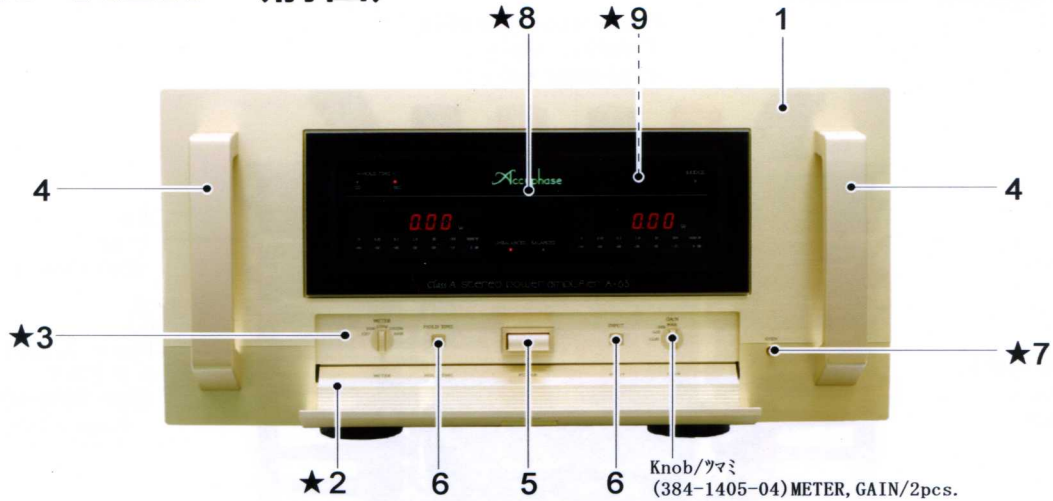

Front Panel Assembly
フロントパネル Ass'y
(130-0209-01)

- | | | | |
|---|-------|---|-------|
| 1. Front Panel=131-0209-01
フロントパネル | 1pce. | 6-1. Push-button Frame=113-0111-14
プッシュボタンフレーム | 2pcs. |
| 2. Sub-panel=134-0169-02
サブパネル | 1pce. | 6-2. Coil Spring=285-1023-04
コイルスプリング | 2pcs. |
| 3. Panel Name Plate=180-1108-03
パネルネームプレート | 1pce. | 7. Push-button=388-0402-04
プッシュボタン / OPEN | 1pce. |
| 4. Handle=132-0118-03
取手A | 2pcs. | 7-1. Coil Spring=285-1022-04
コイルスプリング | 1pce. |
| 5. Push-button=388-5061-13
プッシュボタン / POWER | 1pce. | 7-2. Washer=637-0043-04
ワッシャー | 1pce. |
| 5-1. Push-button Frame=113-0143-04
プッシュボタンフレーム | 1pce. | 7-3. E-ring=647-1055-00
Eリング | 1pce. |
| 5-2. Coil Spring=285-1022-04
コイルスプリング | 1pce. | 8. Front Glass=172-0156-03
フロントガラス | 1pce. |
| 5-3. Washer=637-0043-04
ワッシャー | 1pce. | 9. Indicator=173-9105-03
インディケータ | 1pce. |
| 5-4. E-ring=647-1055-00
Eリング | 1pce. | | |
| 6. Push-button=389-5077-13
プッシュボタン / HOLD TIME/INPUT | 2pcs. | | |
| 5-1. Retainer=283-1028-04
軸受 | | | |

Knob/ツマミ
(384-1405-04) METER, GAIN/2pcs.

REAR VIEW (後面)

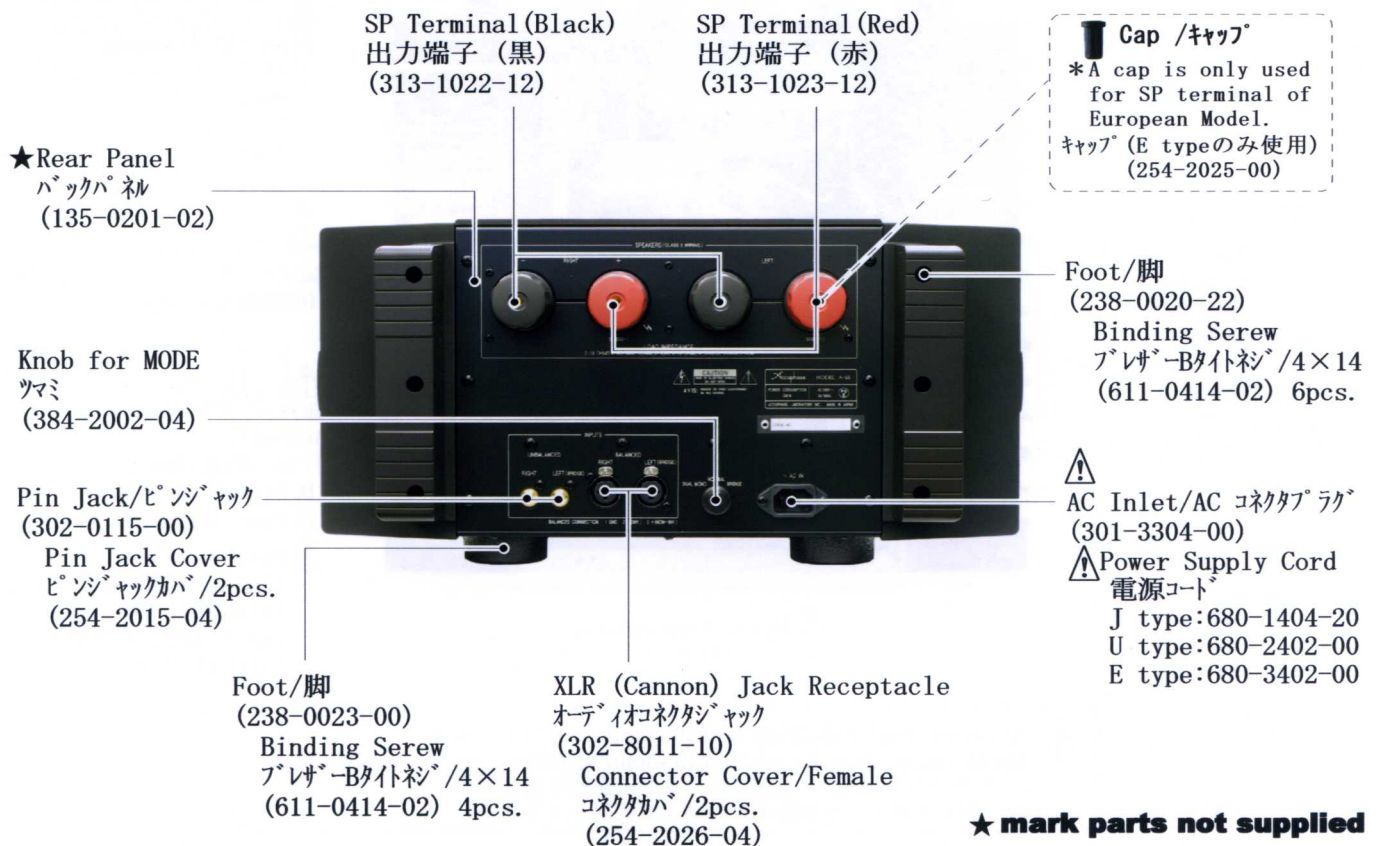

SP Terminal (Black)
出力端子 (黒)
(313-1022-12)

SP Terminal (Red)
出力端子 (赤)
(313-1023-12)

Cap / キャップ
*A cap is only used for SP terminal of European Model.
キャップ (E typeのみ使用)
(254-2025-00)

★Rear Panel
バックパネル
(135-0201-02)

Foot/脚
(238-0020-22)
Binding Serew
フレキサ-タイネジ / 4×14
(611-0414-02) 6pcs.

Knob for MODE
ツマミ
(384-2002-04)

Pin Jack/ピンジャック
(302-0115-00)
Pin Jack Cover
ピンジャックカバー / 2pcs.
(254-2015-04)

⚠ AC Inlet/AC コネクタプラグ
(301-3304-00)

⚠ Power Supply Cord
電源コード
J type: 680-1404-20
U type: 680-2402-00
E type: 680-3402-00

Foot/脚
(238-0023-00)
Binding Serew
フレキサ-タイネジ / 4×14
(611-0414-02) 4pcs.

XLR (Cannon) Jack Receptacle
オーディオコネクタジャック
(302-8011-10)
Connector Cover/Female
コネクタカバー / 2pcs.
(254-2026-04)

★ mark parts not supplied
マーク部品は供給出来ません

FRONT VIEW (Sub-chassis side) (サブシャーシ前面図)

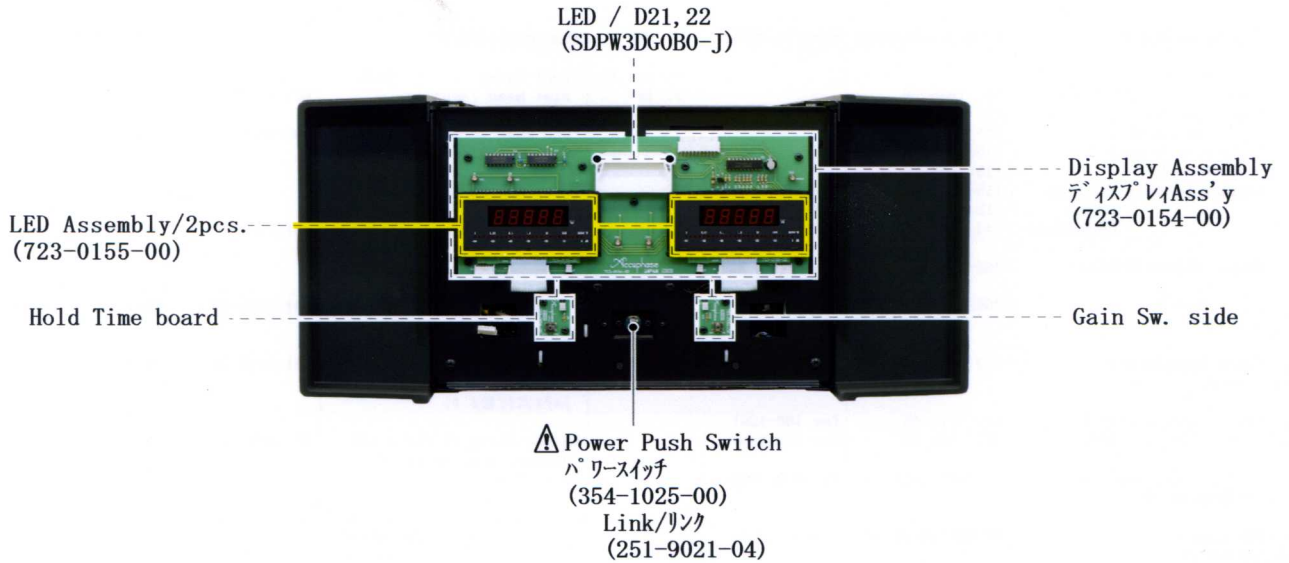

Back View of Front-Panel Assembly (フロントパネル背面図)

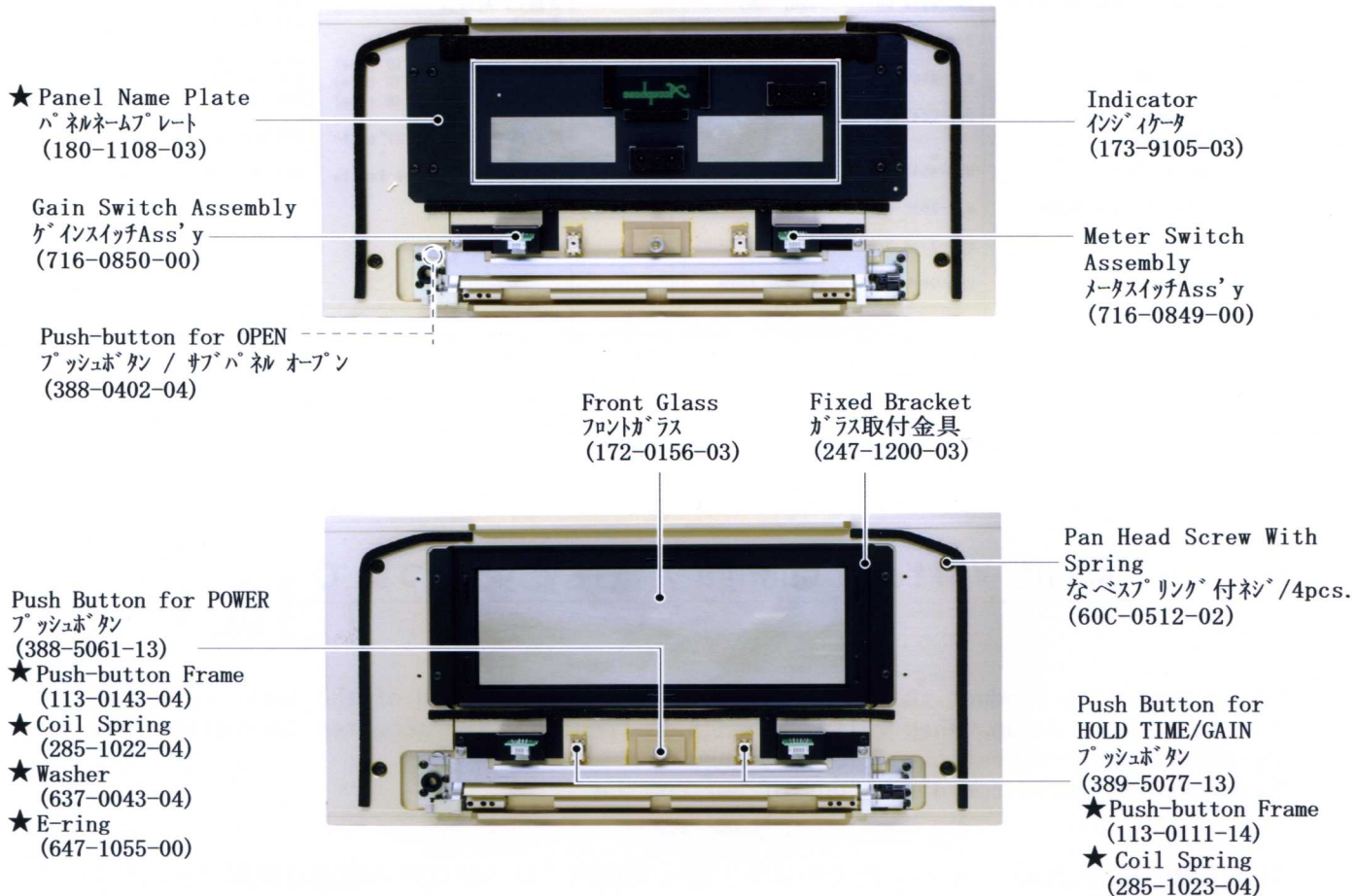

⚠ Attention mark indicating critical components for safety.
Replacement must be made with identical parts of special part number.
このマークのついている部品は、安全上重要な部品です。
必ず指定されている部品番号の部品を使用して下さい。

★ mark parts not supplied
マーク部品は供給出来ません

MISCELLANEOUS(本体その他使用部品)

NO	Description(部品名)	Parts No.(部品No.)	Remarks(備考)	NO.	Description(部品名)	Parts No.(部品No.)	Remarks(備考)	
	PC Board for Inrush Protection Ass'y Input Assembly Power Amp Assembly Protection Assembly Logic Assembly Display Assembly (Display) (Gain) (Hold Time)	115-1946-00 115-1944-00 115-1943-00 115-1945-00 115-1955-00 115-1949-00 115-1950-00 115-1951-00	メイン部 ゲインスイッチ部 ホールドタイムスイッチ部		Screws for ネジ類	Front Panel / フロントパネル用 Flat Head / 皿底タイプネジ Handle A / フロントパネル用取手 Pan Head Screw with Spring なべスプリング付ネジ Power Amp Assembly パワーアンプ Ass'y 用 Hexa Hole bolt/六角穴付ロック ボルト	613-0412-01 60C-0512-02 631-0011-10	4×12mm 6pcs. M5×12 4pcs. M5×12mm 12pcs.
RELAY2, 3	Output Relay/出力リレー	362-2230-00	Protection Ass'y		Handle B / ヒートシールド取手用 Hexa hole Bolt/六角穴付ロック ボルト	631-0019-00	M4×8mm 10pcs.	
S001	Power Switch パワースイッチ	354-1025-00			Top Plate / トッププレート用 Star-hole Bolt 六角穴付皿底ボルト	631-0048-00	M5×15 7pcs.	
T001	Power Transformer パワートランス	510-2064-00			Bottom Plate / ボトムプレート用 Binding Neil Screw バインドネジ	631-0054-00	3×10mm 13pcs.	
F1	Fuse T20A L AC250V フューズ TSA L AC250V	310-9911-00 310-1802-00	for 100-120V for 220-240V		Foot for Bottom side/ボトム脚用 Binding Screw/平ネジ-皿底タイプネジ Foot for Rear side/バックパネル用 Binding Screw/平ネジ-皿底タイプネジ	611-0414-02 611-0414-02	4×14mm 4pcs. 4×14mm 6pcs.	
C002, 3	Electrolytic Capacitor アルミ電解コンデンサ	CE331WG1J823CST	82,000uF/63V		Power Transformer/電源トランス Binding Screw/なべスプリング付 ネジ	60C-0614-02	4pcs.	
C001	MMP Capacitor MMPコンデンサ	CF99MF2E473MR46	0.047uF/250V		Owner's Manual (多ヶ国語) 取扱説明書 (日本語) Caution Notes (多ヶ国語) 注意書 EC適合宣言書	820-3259-00 820-0259-10 821-0011-00 821-0010-00 827-1110-00	Mili-Lingual Japanese Mili-Lingual Japanese E type	
Packing Material 梱包材	Outer Carton Top Box タシボールケース上箱 Inner Sub-Carton タシボールケース Outer Carton Bottom Box タシボールケース下箱 Front Top Pad / トップパッド Rear Top Pad / トップパッド Center Pad / 中パッド Front Bottom Pad/ボトムパッド Rear Bottom Pad / ボトムパッド Joint / ジョイント Cover/保護カバー Accessories Case 付属品ケース Wrapping Sheet/シート Bag for AC Cord/保護カバー Poly Bag/ビニール袋 Cord Band コードバンド	800-0294-04 801-0276-00 801-0277-00 803-0436-00 803-0437-00 803-0435-00 803-0438-00 803-0439-00 249-0045-00 810-4867-04 801-0247-20 810-4545-04 810-2030-04 812-2435-04 280-0043-00	See the pate of Packing Front (前) Rear (後) Front (前) Rear (後) 6pcs. 本体用 付属品ケース用 ACコード用 取説用 for AC Cord	Accessories 付属品	目隠しシール/ステッカー 案内状 Power Supply Cord (D type) 電源コード (U type) (E type) Pin Jack Cover / ヒンジキャップカバー Connector Cover for female コネクタカバー (雌タイプ用)	180-9230-00 859-1011-00 680-1404-20 680-2402-00 680-3402-00 254-2015-04 254-2026-04	国内のみ(D only) 国内のみ(D only) 2-conductor 2-conductor 3-conductor 2pcs. 2pcs.	

About Voltage Change / 電圧変更について

The voltage of a product is used according to the safe method of the area. It is set only to 100V in Japan. When voltage change is required, the accepted specialist carries out according to directions of our company. Therefore, it waits for directions of our company.

日本国内の電圧は100Vと定められています。従って国内では100V以外の製品は使用できません。電圧変更が必要な場合は、当社に確認の上指示に従って下さい。

Input Assembly (716-0841-00)

インプット Ass'y

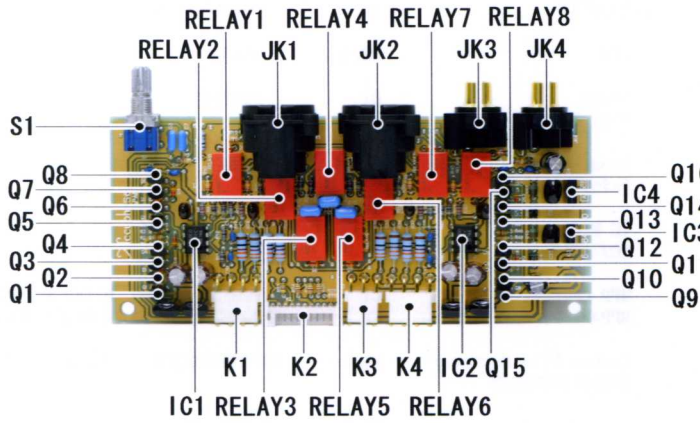

XLR(Canon) Jack Receptacle オーディオコネクタジャック	JK1, 2	302-8011-10
Pin Jack ピンジャック	JK3, 4	302-0115-00
Connector Plug コネクタプラグ	K1, 4 K2 K3	308-0420-00 308-1103-00 308-0318-00
Rotary Switch ロータリースイッチ	S1	336-3903-00
Transistor トランジスタ	Q1, 8, 9, 16 Q4, 5, 12, 13	2SA817-Y 2SC1627-Y
FET	Q2, 7, 10, 15 Q3, 6, 11, 14	2SJ103-Y 2SK246-Y

Relay リレー	RELAY1~8	362-1202-00
Diode ダイオード	D1~13 D14, 16 D15, 17	1SS133 1SR139-400 11EQS10
IC	IC1, 2 IC3 IC4	NJM4580D-D UPC78N18H UPC79N18H
Ceramic Capacitor 磁器コンデンサ	C1, 4, 24, 26 C10, 11, 17, 18	CK92Y5V1H104Z 0.1uF / 50V CC92CH1H331JFK28 330pF / 50V
PPS Capacitor PPSコンデンサ	C2, 8, 20, 23, 27, 28 C6, 12, 16, 22	CQ921HB1H104JH2D 0.1uF / 50V CQ922M1H182JAHSF 1,800pF/50V
Polyester Film Capacitor ポリエステルコンデンサ	C3, 7 C13, 14, 15	CF922N1H223JMMTF 0.022uF/50V CF922N1H334JMMTF 0.033uF /50V
Electrolytic Capacitor アルミ電解コンデンサ	C5, 9, 19, 21 C25, 29	CE04W2A100KMG 10uF / 100V CE04W2A150HE 15uF / 100V
Carbon Film Resistor 炭素皮膜抵抗器	R1~4, 15, 24 26, 28, 46~49 R5, 7, 10, 19, 36, 45, 50 R23, 29	RD142CA100J 10Ω 1/6W RD142CA274J 270kΩ 1/6W RD142CA4R7J 4.7Ω 1/6W
Metal Film Resistor 金属皮膜抵抗器	R6, 17, 38, 44 R9, 13, 42, 43 R11, 12, 40, 41 R14, 39 R16, 18, 20, 22, 32, 33, 34, 37 R21, 25 R27, 30 R31, 35	RN142CK2322F 23.2kΩ 1/6W RN142CK4700F 470Ω 1/6W RN142CK1001F 1kΩ 1/6W RN142CK6490F 649Ω 1/6W RN142HK3320FF 332Ω 1/4W RN142CK4120F 412Ω 1/6W RN142CK8202F 82kΩ 1/6W RN142CK8450F 845Ω 1/6W
Fuse Resistor フューズ抵抗	R8	RF142EAR10J 0.1Ω 1/4W

In-rush Protector Assembly

インラッシュ防止 Ass'y (716-0842-01) for D / U Model
(716-0842-03) for E type Model

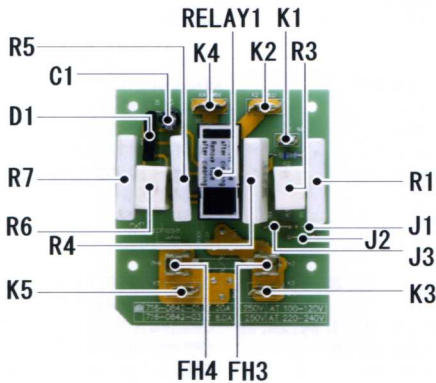

Jumper Setting/ジャンパ-設定

VOLTAGE	Ass'y NO	J1	J2	J3
100-120V	716-0842-01		●	●
220-240V	716-0842-03	●		

Fuse Holder フューズホルダ	FH3, 4	306-2002-00
Tab Terminal タブ端子	K1 K2~5	314-0530-00 314-0536-00
Relay リレー	RELAY1	362-4102-00
Diode ダイオード	D1	S1VB60
Electrolytic Capacitor アルミ電解コンデンサ	C1	CE04W1V101VK 100uF/35V
Fuse Resistor フューズ抵抗	R2 R3, 6	RF142EA4R7J 4.7Ω 5W RF993HG2R2J 2.2Ω 5W
Metal Plate Resistor 金属板抵抗器	R1, 4, 5, 7	RW994AJ3R3J-S 3.3Ω 1W

Diode(A) Assembly (716-0843-00)

ダイオード(A) Ass'y

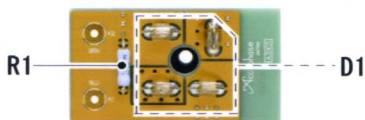

PC Board PCボード		115-1947-00
Diode ダイオード	D1	S25VB60
Oxide Metal Film Resistor 金属酸化皮膜抵抗器	R1	RS143DA100JS 10Ω 2W

Diode (B) Assembly (716-0844-00)

ダイオード(B) Ass'y

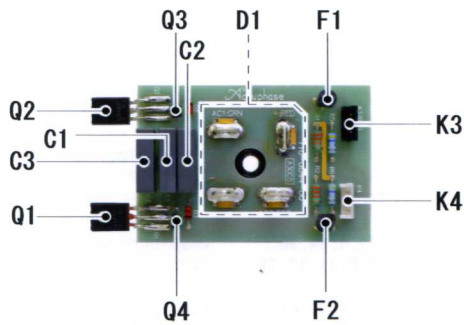

PC Board
PCボード 115-1948-00

Connector Plug
コネクタプラグ K3 308-0314-00
K4 308-0304-00

Transistor トランジスタ	Q1	2SA1507-S/T		
	Q2	2SC3902-S/T		
FET	Q3, 4	2SK330-Y		
Diode ダイオード	D1	S25VB60		
Zener Diode ツェナーダイオード	D2, 3	HZ242L		
IC Protector ICプロテクタ	F1, 2	310-8102-00		
MPP Capacitor MPPコンデンサ	C1	CF99MF2E104MR46	0.1uF / 250V	
	C2, 3	CF99MF2E103MR46	0.01uF / 250V	
Carbon Film Resistor 炭素皮膜抵抗器	R1, 2	RD142HA333JFS	33kΩ	1/4W
Fuse Resistor フューズ抵抗器	R5, 6	RF142EAR47J	0.4.7Ω	1/4W

Meter Switch Assembly (716-0849-00)

メータスイッチ Ass'y

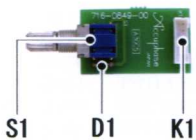

PC Board
PCボード 115-1952-00

Connector Plug
コネクタプラグ K1 308-0606-00

Diode
ダイオード D1 ISS133

Rotary Switch
ロータリースイッチ S1 336-5009-00

Gain Switch Assembly (716-0850-00)

ゲインスイッチ Ass'y

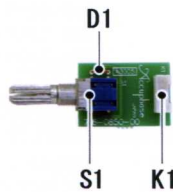

PC Board
PCボード 115-1953-00

Connector Plug
コネクタプラグ K1 308-0508-00

Diode
ダイオード D1 ISS133

Rotary Switch
ロータリースイッチ S1 336-4010-10

Logic Assembly (721-0095-00)

ロジック Ass'y

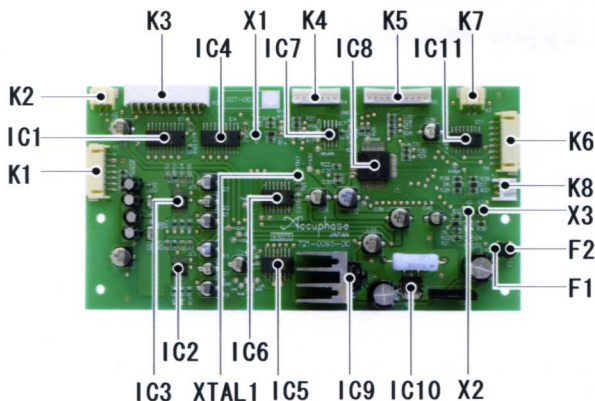

Heat Sink
ヒートシンク HS1 240-2034-10

Connector Jack
コネクタジャック K3 307-2009-00

Connector Plug
コネクタプラグ K1 308-0723-00
K2, 7 308-0235-00
K4 308-0707-00
K5 308-1010-00
K6 308-0819-00
K8 308-0213-00

IC Protector
ICプロテクタ F1, 2 310-8152-00

Reference Diode
定電圧ダイオード D1, 5, 6, 7 RD3.0SB1

Diode
ダイオード D2 S1VB60
D3, 4 ISS387

Crystal セラミック	XTAL1	527-0053-00		
Digital Transistor デジタルトランジスタ	X1, 3 X2	RN2405 RN1405		
IC	IC1, 4 IC2, 3 IC5 IC6 IC7 IC8 IC9 IC10 IC11	TC74HCT244AF/EL AK5355VT-E2 TC74HC08AF/EL TC74VHC04F/EL BR93L66RFJ-WE2 UPD78F1142GB-GAH UPC2405AHF UPC29M33AT TD62003AF		
Electrolytic Capacitor アルミ電解コンデンサ	C1, 6, 32, 33, 36 C2~5 C15, 19, 21, 23, 24, 28, 39 C20, 22, 40 C34, 42	CE32WG0J101WX-T 100uF/6.3V CE04W1C100VPE 10uF / 16V CE32WG1C220WX-T 22uF / 16V CE32WG1H010WX-T 1uF / 50V CE04W1C102VK 1000uF/16V		
PPS Capacitor PPSコンデンサ	C7, 9	CQ725HB1C473JECHU 0.047uF/16V		
Ceramic Capacitor 磁器コンデンサ	C8, 10~14, 16~18, 27 29, 30, 35, 37, 38, 41 C31	CK725B1E104K16T 0.1uF / 50V CK725F1C474Z16T 0.47uF/16V		
Metal Film Resistor 金属混合皮膜抵抗器	R1~6, 8, 9, 11, 12, 22 24, 25, 29, 30 R7, 10, 13 R14, 21, 26~28, 36, 37 R15, 35, 38 R16, 19, 40 R17, 34 R18 R20 R23, 31, 32, 33 R39	RK73K1J220JE-T 22Ω 1/6W RK73K1J470JE-T 47Ω 1/6W RK73K1J104JE-T 100kΩ 1/6W RK73K1J182JE-T 1.8kΩ 1/6W RK73K1J472JE-T 4.7kΩ 1/6W RK73K1J102JE-T 1kΩ 1/6W RK73K1J333JE-T 33kΩ 1/6W RK73K1J103JE-T 10kΩ 1/6W RK73K1J332JE-T 3.3kΩ 1/6W RK73K1J561JE-T 560Ω 1/6W		
Oxide Metal Film Resistor 金属酸化皮膜抵抗器	R41	RS143FA150JS-P 15Ω 3W		

Power Amp Assembly (717-0096-00)

パワーアンプ Ass'y

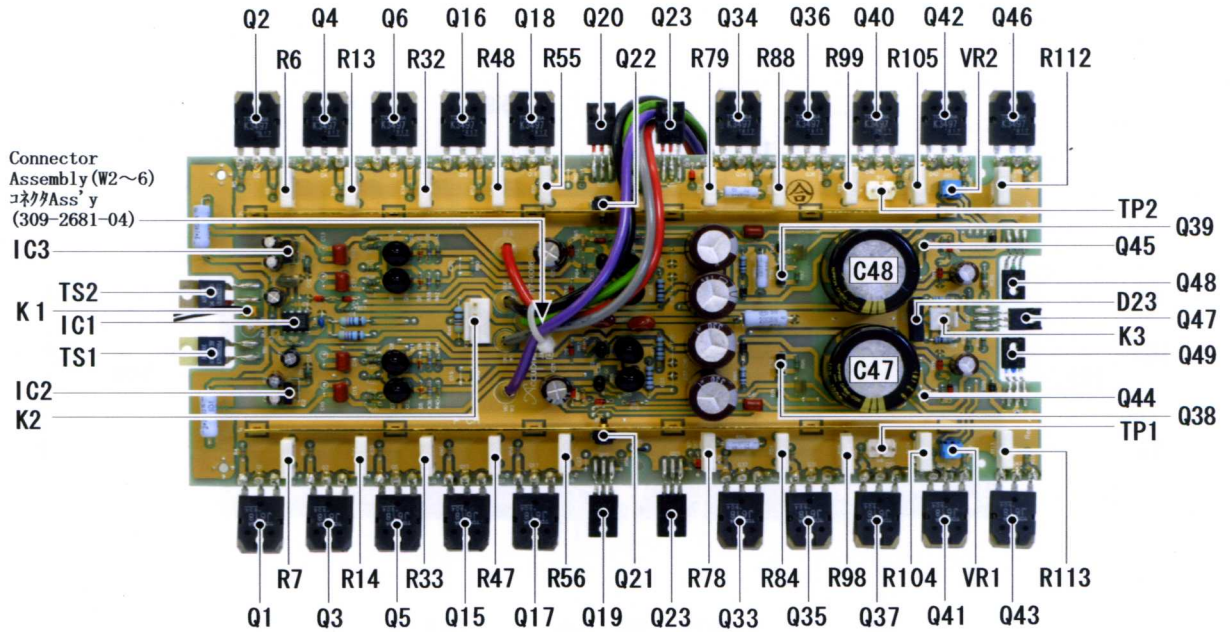

Connector Ass'y コネクタAss'y	K1 W2~6	309-3206-04 309-2681-04	Polypropylen Capacitor ポリプロピレンコンデンサ	C26, 32	CQ921PG2A473JDTNF	0.047pF/100V
Connector Plug コネクタプラグ	K2 K3 TP1, 2 (Test Point)	308-0416-00 308-0212-00 308-0221-00	Ceramic Capacitor 磁器コンデンサ	C3, 14 C25, 27	CK92Y5V1H104Z CC92CH2J151JFK26	0.1uF / 50V 150pF / 630V
Potentiometer 半固定抵抗器	VR1, 2	583-0227-00	MP Capacitor MPコンデンサ	C15~18, 41, 42	CF922MG2E104KMMX	0.1uF / 250V
IC	IC1 IC2 IC3	NJM5532D-D UPC79N18H UPC78N18H	PPS Capacitor PPSコンデンサ	C28~31	CQ922M1H472JAHSF	4700pF / 50V
Thermal Switch サーマルスイッチ	TS1 TS2	369-0035-00 369-0029-00	Carbon Film Resistor 炭素皮膜抵抗器	R3 R4, 8, 11, 18, 30, 34, 45, 52 54, 55, 76, 81, 83, 92, 95 100, 102, 106, 111, 118 R5, 9, 12, 19, 31, 35, 44, 51 53, 58, 75, 80, 82, 93, 94 101, 103, 107, 110, 119 R10, 17 R20, 24, 25, 29 R21, 23, 26, 28, 40~43 R22, 27, 59, 60, 70, 71 114, 115 R49, 50 R61, 62, 63, 65 R64 R66~69 R96, 97 R116 R117 R120	RD142EA822JFS RD142EA332JFS RD142EA331JFS RD142EA303JFS RD142EA513JFS RD142EA220JFS RD142EA101JFS RD142EA753JFS RD142CA621J RD142EA623JFS RD142EA102JFS RD142EA471JFS RD142EA620JFS RD142EA821JFS RD142EA3R9JF	8.2k Ω 1/4W 3.3k Ω 1/4W 330 Ω 1/4W 30k Ω 1/4W 51k Ω 1/4W 22 Ω 1/4W 100 Ω 1/4W 75k Ω 1/4W 620 Ω 1/6W 62k Ω 1/4W 1k Ω 1/4W 470 Ω 1/4W 62 Ω 1/4W 820 Ω 1/4W 3.9 Ω 1/4W
Diode ダイオード	D1, 2 D5, 6, 7, 8 D15, 16 D19, 20~22, 28, 29 D23	11EQS10 1SS133 1SS83 1SR139-400 LN1VB60	Fuse Resistor フューズ抵抗器	R72, 73, 74, 77 R85, 87, 108, 109	RF142HA101J RF142EAR10J	100 Ω 1/2W 1 Ω 1/4W
Zener Diode ツェナーダイオード	D3, 4 D9, 10, 11, 12 D13, 14, 17, 18 D24, 25 D26, 27	HZ9A2L HZ153L HZ6C2L HZ272L HZ242L	Metal Film Resistor 金属皮膜抵抗器	R1, 2 R15, 16, 46 R36, 37, 38, 39	RS143FA222JS-P RN142HK4321FF RN142CK1621F	2.2k Ω 1/4W 432 Ω 1/4W 162 Ω 1/6W
Transistor トランジスタ	Q7, 9, 11, 12 Q8, 10, 13, 14 Q19, 23 Q20, 28 Q21, 48 Q22, 49 Q24, 26, 29, 31 Q25, 27, 30, 32 Q38 Q39 Q47	2SC2909-S/T 2SA1207-S/T 2SA1837 2SC4793 2SC3902-S/T 2SA1507-S/T 2SC2705-Y 2SA1145-Y 2SA1428-Y 2SC3668-Y 2SC3421-Y	Metal Plate Resistor 金属板抵抗器	R6, 7, 13, 14, 32, 33, 47, 48, 56, 57, 78, 79, 84, 88 98, 99, 104, 105, 112, 113	RW993DJR22K-H	0.22 Ω 2W
FET	Q1, 3, 5, 15, 17, 33, 35 37, 41, 43 Q2, 4, 6, 16, 18, 34 36, 40, 42, 46 Q44, 45	2SJ618 2SK3497 2SK330-Y	Oxide Metal Film Resistor 金属酸化皮膜抵抗器	R86 R89, 91 R90	RS143FA200JS-P RS143DA682JS-P RS143DA680JS-P	20 Ω 3W 6.8k Ω 2W 68 Ω 2W
Electrolytic Capacitor アルミ電解コンデンサ	C1, 2, 5, 6 C4, 7 C21, 22 C37~40 C47, 48 C49, 50	CE04W1H220KZEE CE04W1H100VPE CE04W2D220PBE CE04W2A331KMG CE692WG2A102M14 CE04W2A220LXVE	Heat Sink ヒートシンク		240-0098-00	
Polyester Capacitor ポリエステルコンデンサ	C8 C43, 44	CQ921MQ1H104KF2D CQ921MQ2A682KF2D	Transistor Insulator 絶縁スベーク		250-1234-14	0.1uF / 50V 6,800pF/100V

Protection Assembly (720-0084-00)

プロテクション Ass'y

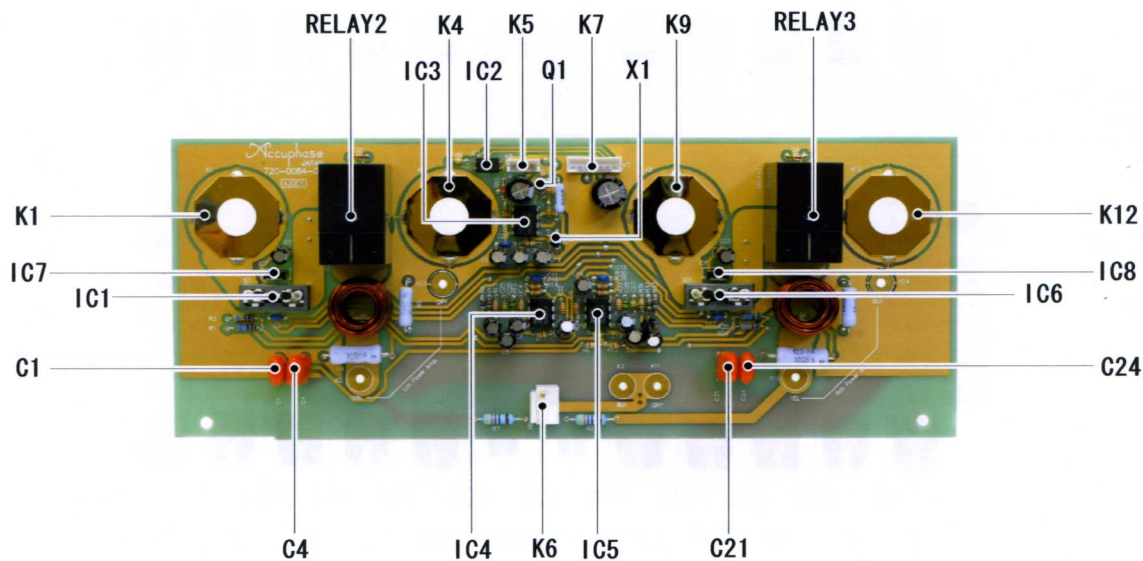

Connector Plug コネクタプラグ	K5	308-0304-00	Ceramic Capacitor 磁器コンデンサ	C2, 11, 15, 22, 29	CK92Y5V1H104Z	0.1uF / 50V	
	K6	308-0317-00		C25, 27	CC14CH1H471JN	15pF / 50V	
	K7	308-0707-00		C26, 28	CC14CH1H151JS	150pF / 50V	
Terminal 端子	K1, 4, 9, 12	314-0523-04	Electrolytic Capacitor アルミ電解コンデンサ	C3, 8, 18, 23	CE04W0J221VRE	220uF / 6.3V	
	Relay リレー	RELAY2, 3		362-2230-00	C5, 7, 19, 20	CE04W1C100VPE	10uF / 16V
C6					CE04W1H4R7VK	4.7uF / 50V	
C9					CE04W2A470VK	47uF / 100V	
Choke Coil チョークコイル	L1, 2	506-0013-00		C10	CE04W1A221VK	220uF / 10V	
				C12	CE04W1H220VK	22uF / 50V	
Diode ダイオード	D2, 3, 4	1SS133		C13, 14	CE04W0J101VRE	100uF / 6.3V	
				C17	CE04W1A102VRE	1000uF / 10V	
Transistor トランジスタ	Q1	2SA1049-BL		Carbon Resistor 炭素皮膜抵抗器	R6, 10, 38	RD142CA104J	100k Ω 1/6W
					R8	RD142CA154J	154k Ω 1/6W
Digital Transistor デジタルトランジスタ	X1	RN1202	R12		RD142CA822J	8.2k Ω 1/6W	
			R13, 15, 17, 22, 24, 25, 29, 31		RD142CA103J	10k Ω 1/6W	
Hall IC ホールIC	IC1, 6	CQ121E	R14, 16, 26, 30		RD142CA472J	4.7k Ω 1/6W	
			IC		IC2 IC3 IC4, 5 IC7, 8	PC817-B/C UPC1237C-A NJM4580D-D TA48M04FS	R18
Polypropylen Capacitor ポリプロピレン コンデンサ	C1, 4, 21, 24	CQ922N2A473JAPSF					0.047uF/100V
			Oxide Metal Film Resistor 金属酸化皮膜抵抗器		R4, 36 R5, 37 R23	RS143FA100JS-P RS143DA100JS-P RS143AA332JS-P	
R1, 35	RN143EK5760F	576 Ω 1/6W					
Metal Film Resistor 金属皮膜抵抗器	R3, 34	RN142EK4642F	R7, 21		RN142HK4321FF	4.32k Ω 1/6W	
			R9, 33	RN142CK3601F	3.6k Ω 1/6W		
Metal Film Resistor 金属皮膜抵抗器	R11, 32	RN142CK2401F	R20	RD142CA221J	220 Ω 1/6W		

Display Assembly (723-0154-00)

ディスプレイ Ass'y

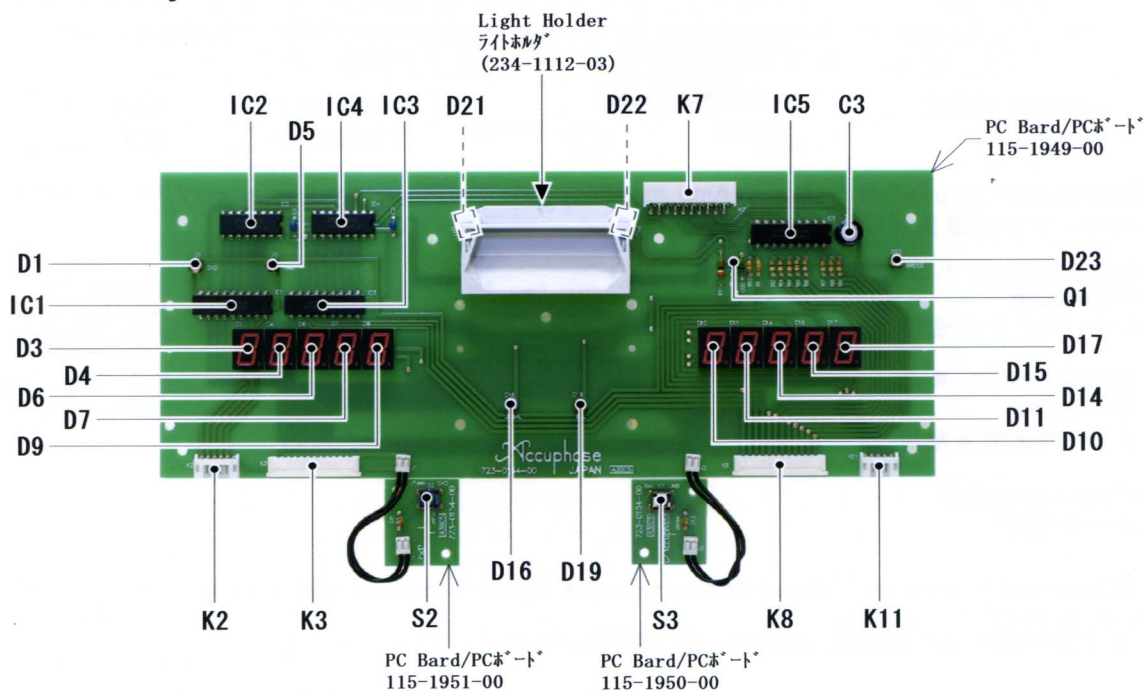

PC Board PCボード	115-1949-00 for Display 115-1950-00 for GAIN 115-1951-00 for HOLD TIME	Zener Diode ツェナーダイオード	D20	HZ3ALL
LED Spacer LEDスペーサ	D1, 5, 16, 19, 23用 250-1117-00 D21, 22用 250-0061-00	Transistor, トランジスタ	Q1	2SC2458-GR
Connector Plug コネクタプラグ	K2 308-0609-00 K11 308-0514-00	IC	IC1, 3 IC2, 4 IC5	TD62381P TC74HC238AP TD62786AP
Connector Jack コネクタジャック	K3, 8 307-1205-00 K7 307-2009-00	Ceramic Capacitor 磁器コンデンサ	C1, 2	CK92Y5V1H104Z 0.1uF/50V
Push Switch プッシュスイッチ	S2, 3 354-1117-00	Electrolytic Capacitor アルミ電解コンデンサ	C3	CE04W0J221MA 220uF/6.3V
LED	D1, 5, 16, 19, 23 FR3864X D3, 4, 6, 7, 9, 10 LA-401VN 11, 14, 15, 17 D21, 22 SDPW3DG0B0-J	Carbon Film Resistor 炭素皮膜抵抗器	R1 R2~9 R10 R11	RD142CA221J 220Ω 1/6W RD142CA910J 91Ω 1/6W RD142CA152J 1.5kΩ 1/6W RD142EA390J 39Ω 1/4W
Diode ダイオード	D8, 13 1SS133			

LED Assembly (723-0155-00)

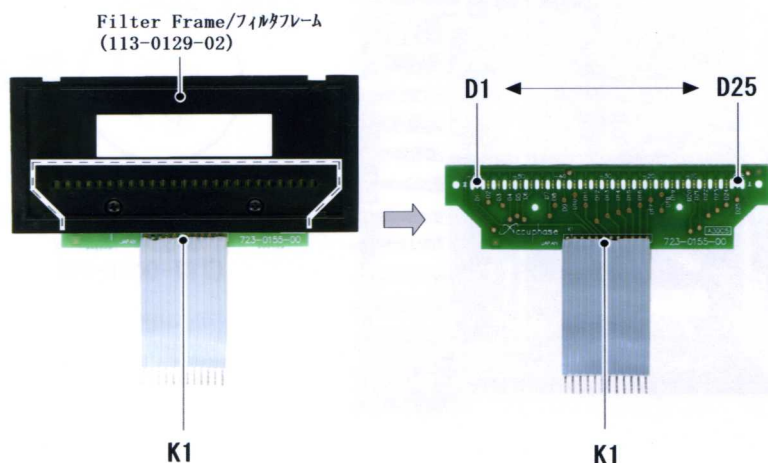

PC Board PCボード	115-1954-00
Filter Frame フィルタ取付フレーム	113-0129-02
Flat Cable フラットケーブル	K1 673-1204-10
LED	D1~25 UR1111C-B/C/D

CIRCUIT ADJUSTMENT (回路調整)

- Notes
- ※1. Internal input resistance of volt-ohm meter should be higher than 10k-ohms.
テスターは、入力抵抗10kΩ以上のものをお使い下さい。
 - ※2. Adjustments should be made in case of the PC Board or Transistors being changed.
調整はPCボードあるいはトランジスタを交換した場合に行ってください。
 - ※3. After feeding 1~10 watts output for about 15 minutes, check bias adjustment again.
出力1~10ワット前後で通電動作させた後、バイアス電流を再チェックします。

STEP	ADJUST ITEM	PROCEDURE		ADJUST 調整箇所	REMARKS 調整・備考
		TEST EQPT 検出器	CONNECTING POINT 接続点		
1	Bias Current Adjustment for Power Amp Assembly (Located Power Amp Assembly / 717-0096-00) パワーアンプ無信号電流の調整				
	Bias Current of L ch. Power Amp L ch. バイアス電流	V. O. Meter set range to less than DC 0.3V	Power Amp Ass'y パワーアンプ Ass'y (717-0096-00)	VR2 for L ch.	Adjust for 32mV reading of V. O. meter
	Bias Current of R ch. Power Amp R ch. バイアス電流	テスター DC0.3V以下 のレンジ	Test Point pin テストポイント ⊕ ⊖	VR1 for R ch.	テスターの指示 32mVに調整する

2 Meter Calibration メータ調整

"50W Adjustment connection" shown in the following figure is set up, and it carries out according to page12 procedure.
下図に示す"50W調整接続"を設定し、12頁の手順に従い行います。

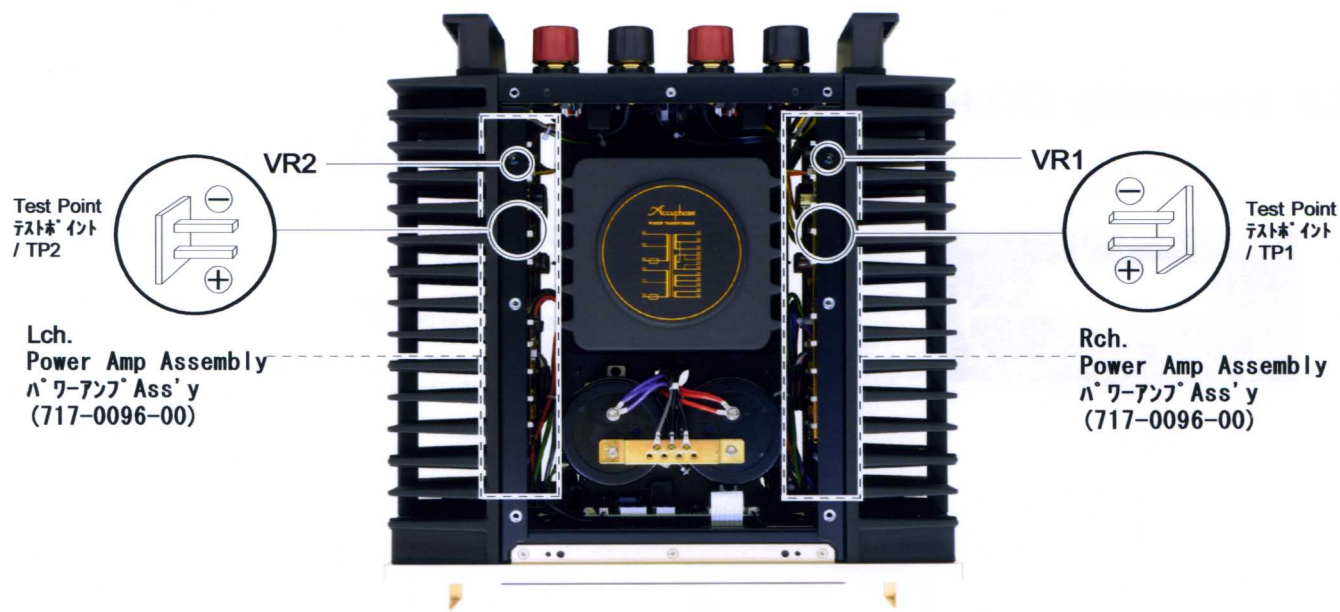
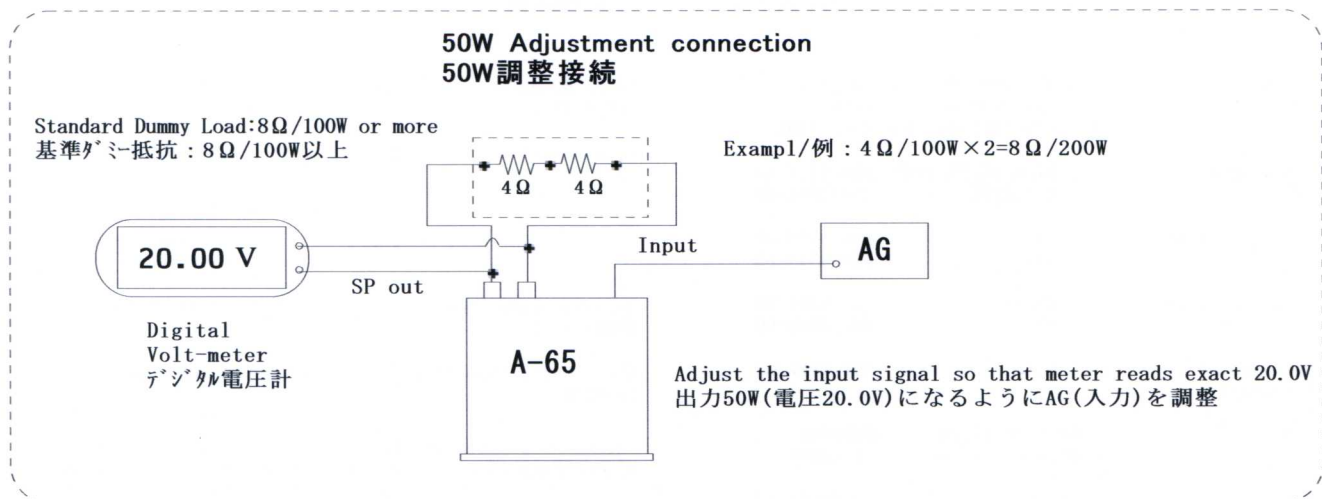

Adjustment Mode / 調整モード (“50W Adjustment Connection” / “50W調整接続”設定)

- Power Supply Switch is turned on with Meter switch in OFF position, if “Hold Time” is pushed 6 times before output relay turns on, the adjustment mode of Fig. 2 will be displayed. “Meter Switch:Off”で電源をオン、出力リレーが動作する前に “Hold Time”を6回押すと図2の調整モードの “UrA” “UrA”表示します。



Fig.1

- ①Power at on with Meter Switch OFF “Meter Off”で電源をオン
- ②Hold Time is pushed on 6 times or more within an output muting time. See Fig.2 出力ミュート時間内にHold Timeスイッチを6回押す。

Adjustment Mode: “UrA” “UrA”/調整モードの表示



Fig.2

- ①Meter switch is set to “BAR”. Meterスイッチを “BAR”にセット
- ②If Hold Time is pushed for 5 seconds, it will become the display of Fig. 3. Hold Timeを5秒押すと図3の表示になります

“Adj-P” “InP=0”表示



Fig.3

Hold Time

Hold Time is pushed twice after checking the display of Fig. 3, and it is made “Lch meter adjustment” shown in Fig. 4.

図3の表示を確認後、Hold Timeを2回押し、図4に示す “Lchメータ調整”にします。

Display shows: “Pon-L” “00.000”



Fig.4

- Lch Power Meter Adjustment/ Lchメータ調整
If “Hold Time” is pushed, adjustment will begin. “Hold Time”を押すと調整が開始します。

Fig.5



①Hold Time

The display on the right side of Fig. 6 begins countdown, adjustment finishes in about 10 seconds, and as shown in Fig. 7, for 3 seconds displays average value.

図6の右側の表示がカウントダウンを始め約10秒で調整が終わり、図7に示す様に平均値を3秒間のみ表示。

Countdown about 10 seconds / カウントダウン約10秒

Fig.6



Average value display / 調整の平均値表示

Fig.7



For 3 seconds, after a display, it shifts to Rch meter adjustment automatically, and average value is displayed as “Pon-r” “00.000.” 平均値を3秒間表示後、自動的にRchメータ調整に移行し “Pon-r” “00.000”と表示。

- Rch Power Meter Adjustment/ Rchメータ調整:
Rch as well as Lch is adjusted automatically. RchもLch同様に自動調整されます

After displaying the average value of Rch. for 3 seconds, the display of “End” of Fig. 8 shows the completion of adjustment.

Rch. の平均値を3秒間表示させた後、図8の “End”の表示で調整完了を示します。

Display : “Adj-P” “End”

Fig.8



A power supply is turned off and meter adjustment is finished. It turns on again, and indicates by meter with the small output 0.020W, and the difference of L/R is checked.

1度電源を切りメータ調整を終了させ、最後に小出力0.020W設定でメータ表示させL/Rの差を確認します。

[Standard/規格 : 0.020W ± 50% / 0.03W ~ 0.01W]

Fig.9



If the difference of L/R is in a standard, the power is turned off and it is an end. L/Rの差が規格内なら電源を切り終了です。

Please perform page13 “Offset measurement” at the time besides a standard. 規格外の時は、13頁のオフセット測定を行って下さい

Meter offset adjustment / メーターオフセット調整

When the difference of the directions offset value of the L/R channel at the time of a small output is large, this adjustment is performed, but it is unnecessary when small. In addition, after step Fig.4 end, this adjustment returns to page12 step Fig.5, adjusts and is ended.

小出力時のL/Rチャンネルの指示値の差が大きい場合にこの調整を行いますが、小さい時は必要ありません。尚、この調整はステップFig.4終了後、12頁ステップFig.5に戻り調整を行い終了します。

• Adjustment Mode / 調整モード

Power Supply Switch is turned on with Meter switch in OFF position, if "Hold Time" is pushed 6 times or more before an output relay turns on, the adjustment mode of "UrA" "UrA" of Fig.1 will be displayed.

"Meter Switch:Off"で電源をon、出力リレーがonする前に"Hold Time"を6回押しすと図1の調整モードの"UrA" "UrA"表示します。

AdjustmentMode"UrA" "UrA" / 調整モードの表示

Display shows "AdJ-P" "InP=0" / 表示



Fig.1

①Meter Sw. set to "BAR"
MeterスイッチをBARにします。

②If "Hold Time" is pushed for 5seconds,
it will become the display in Fig.2
Hold Timeを5秒押し続け図2,の表示にします。

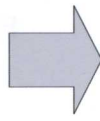

Fig.2

①Hold Time

If display "AdJ-P InP=0" of Fig. 2 is checked and ①Hold Time is pushed once, "offset measurement" shown in Fig. 3 will be started.

A right side display counts down for 8 seconds, and as shown in Fig. 4, for 3 seconds displays a measurement result.

図2の表示"AdJ-P "InP=0"を確認して①Hold Timeを1回押しすと図3に示す"オフセット測定"を開始します。右の表示が8秒間カウントダウンし図4の様に測定結果を3秒間のみ表示します。

Standard/規格:0.020W±50% /0.03W~0.01W

Display shows "OFF5" "0008"

Fig.3



Countdown about 8 seconds
カウントダウン約8秒

Fig.4



30>上位2桁の数値

"U 21.21"

Offset measured value
オフセット測定数値

Lch.="U 21.21" Rch.="I 19.18"

30>上位2桁の数値

"I 19.18"

Although offset measurement result "U**.*" "I**.*" displays for only 3 seconds, when the differences of L/R are slightly, it is no problem.

オフセット測定結果"U**.*" "I**.*"は3秒間のみ表示しますが、L/Rの差がわずかな場合は問題ありません。

When the the offset measured value of L/R displays 30 or more, please repeat the above adjustment again and make the offset value of L/R small.

L/Rの数値がいずれか30以上を表示した場合、再度上記の調整をくり返し値を30以下にください。

After offset measurement, a display will be 12 page step Fig.5, in the procedure, performs meter adjustment and is completed.

オフセット測定後、表示は12頁ステップFig.5となりその手順でメータ調整を実行し終了します。

PACKING (梱包図)

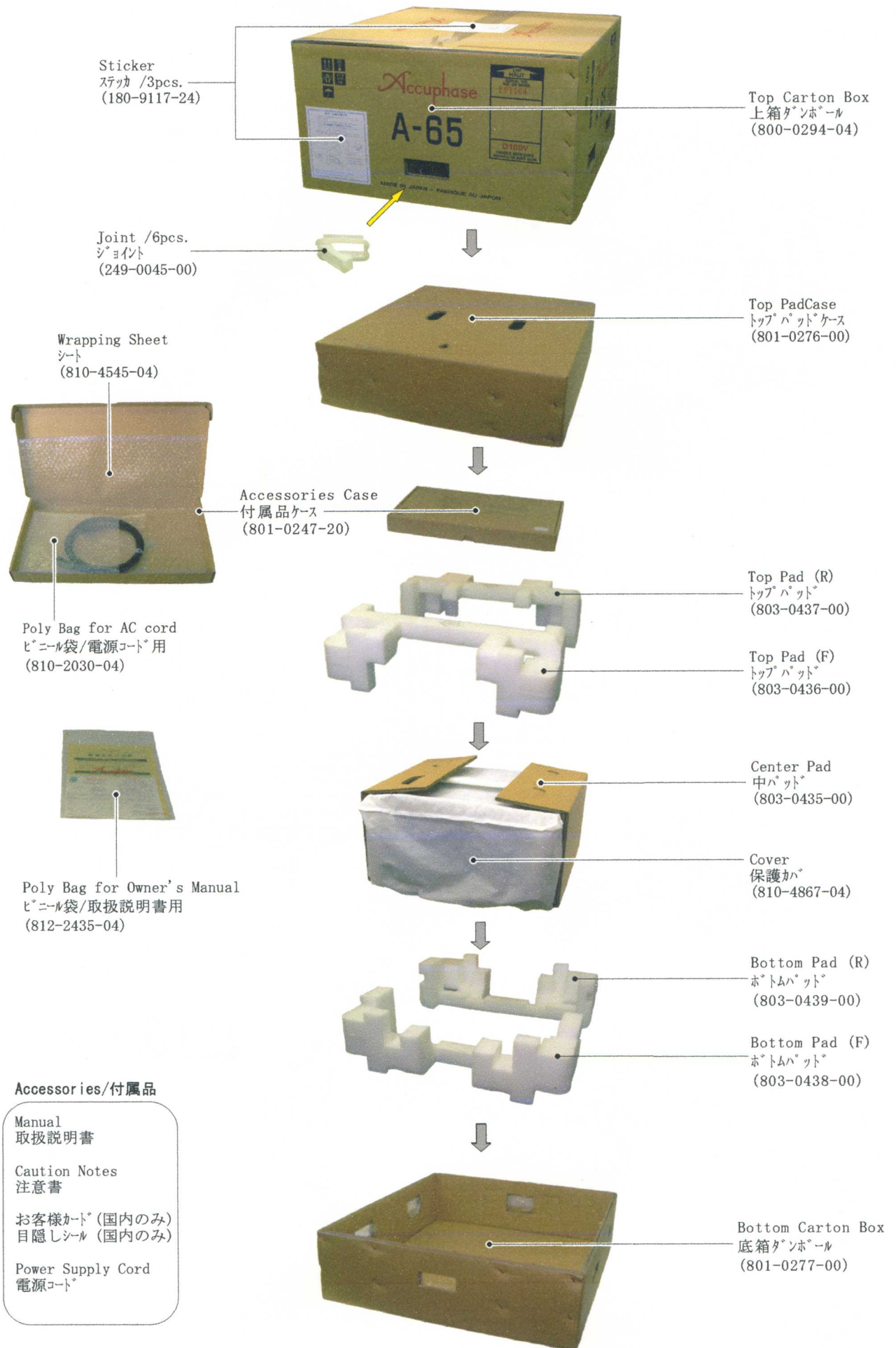

A-65 MASTER CIRCUIT DIAGRAM

- 15 -

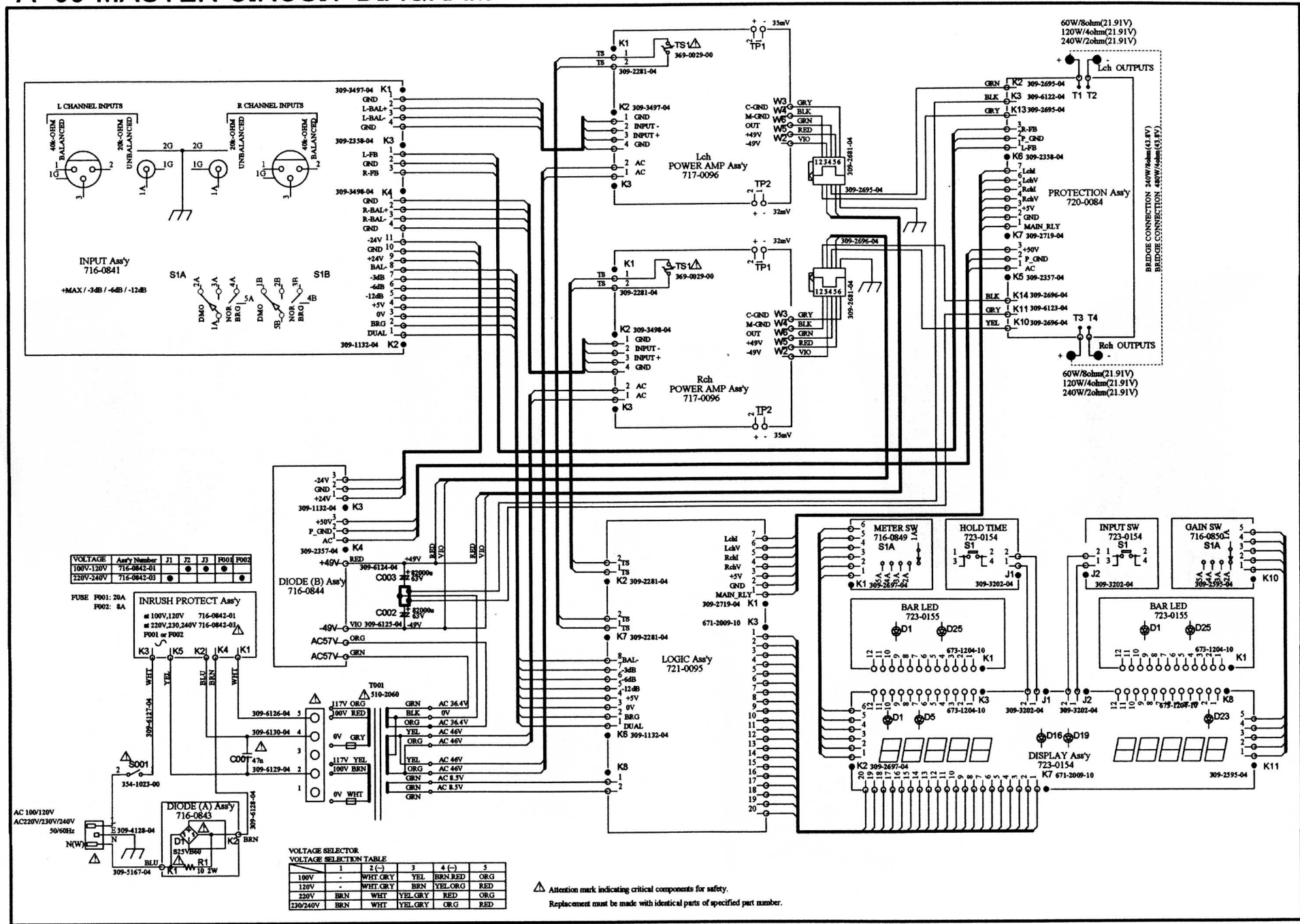

VOLTAGE	Assy Number	J1	J2	J3	F001	F002
100V-120V	716-0842-01	●	●	●	●	●
220V-240V	716-0842-03	●	●	●	●	●

FUSE F001: 20A
F002: 8A

INRUSH PROTECT Assy
#1 100V,120V 716-0842-01
#2 220V,230,240V 716-0842-03
F001 or F002

VOLTAGE SELECTOR
VOLTAGE SELECTION TABLE

	1	2 (-)	3	4 (-)	5
100V	-	WHT GRY	YEL	BRN RED	ORG
120V	-	WHT GRY	BRN	YEL ORG	RED
220V	BRN	WHT	YEL GRY	RED	ORG
230/240V	BRN	WHT	YEL GRY	ORG	RED

⚠ Attention mark indicating critical components for safety.
Replacement must be made with identical parts of specified part number.

A-65 INPUT ASS'Y (716-0841-00)

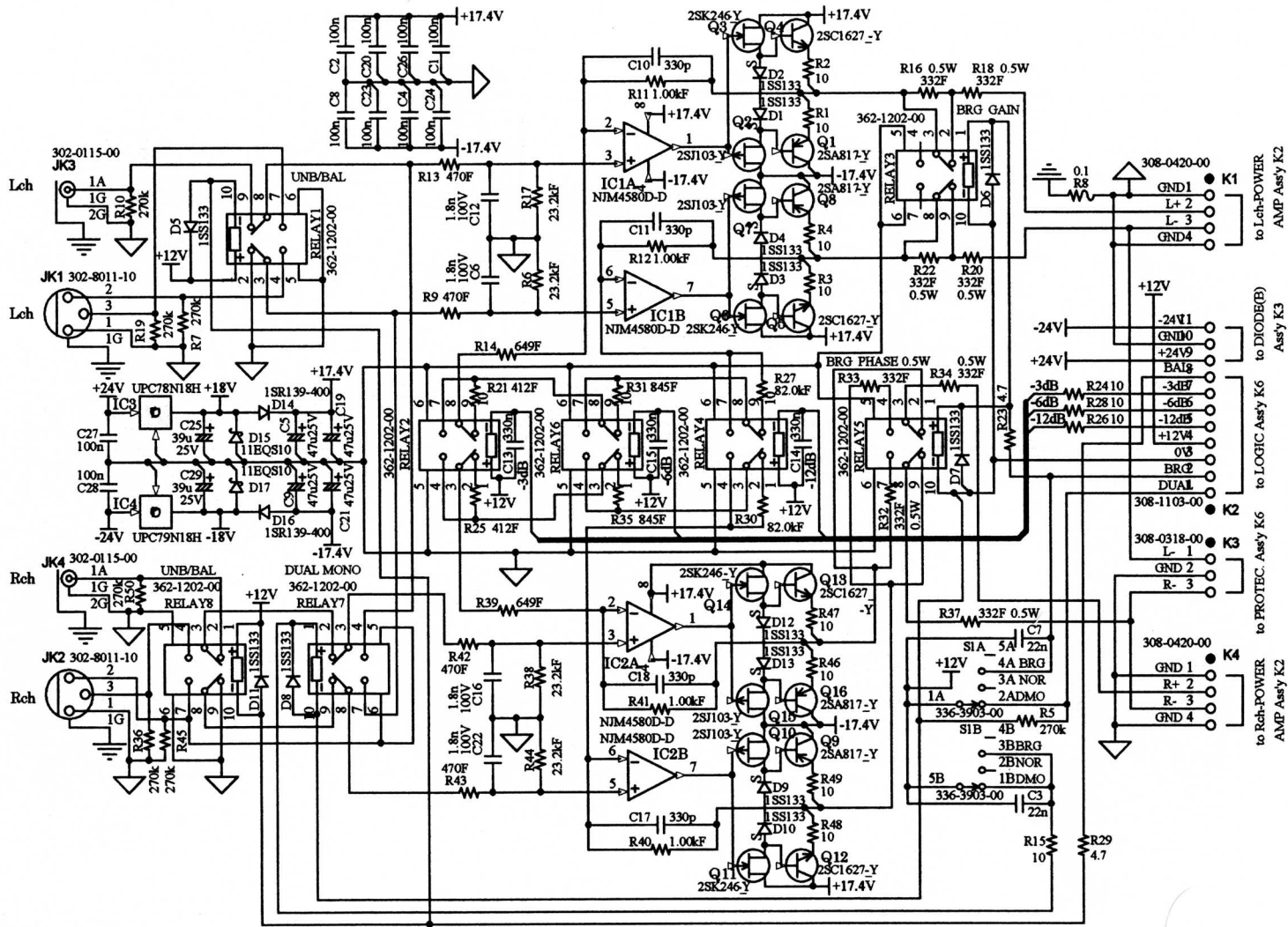

IN-RUSH PROTECTOR ASS'Y (716-0842-01/03)

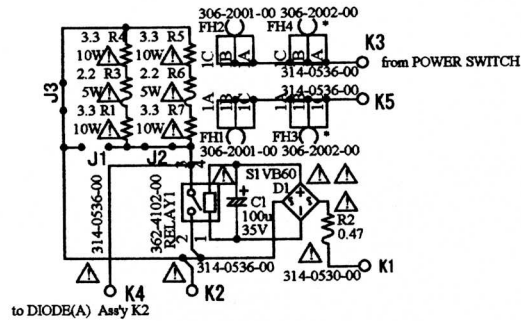

INRUSH PROTECTION Assy

Type	Assy No.	FUSE	HOLDER	JUMPER
D, L (100, 120V)	716-0842-01	T-20A	FH3, 4	J2, 3
E, B (230, 240V)	716-0842-03	T-8A	FH1, 2	J1

Remarks: Circuit shows D (AC100V) setting.
 Attention mark indicating critical components for safety.
 Replacement must be made with identical parts of specified part number.

DIODE(A) ASS'Y (716-0843-00)

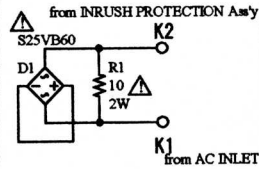

METER SWITCH ASS'Y (716-0849-00)

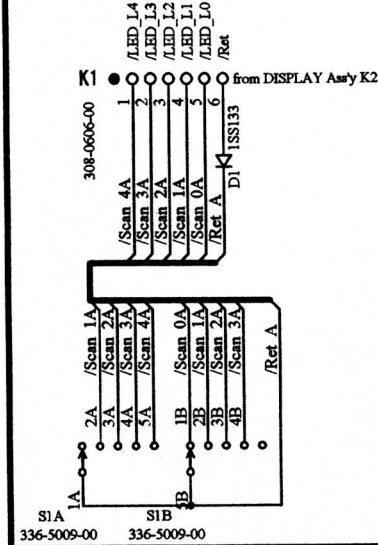

GAIN SWITCH ASS'Y (716-0850-00)

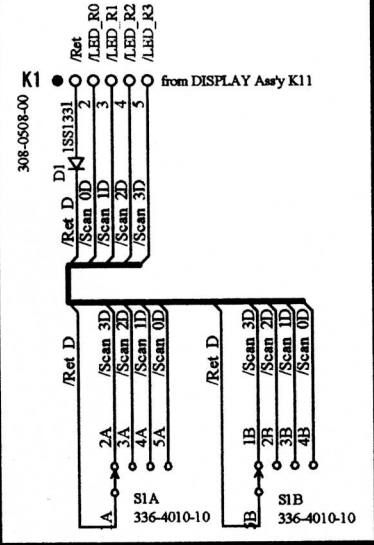

DIODE(B) ASS'Y (716-0844-00)

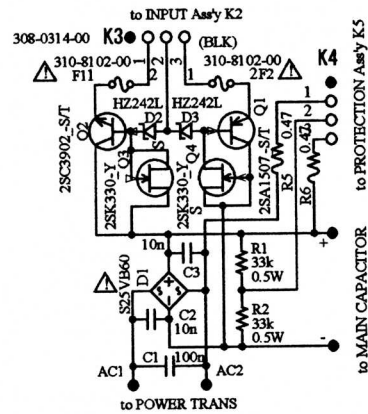

LED ASS'Y (723-0155-00)

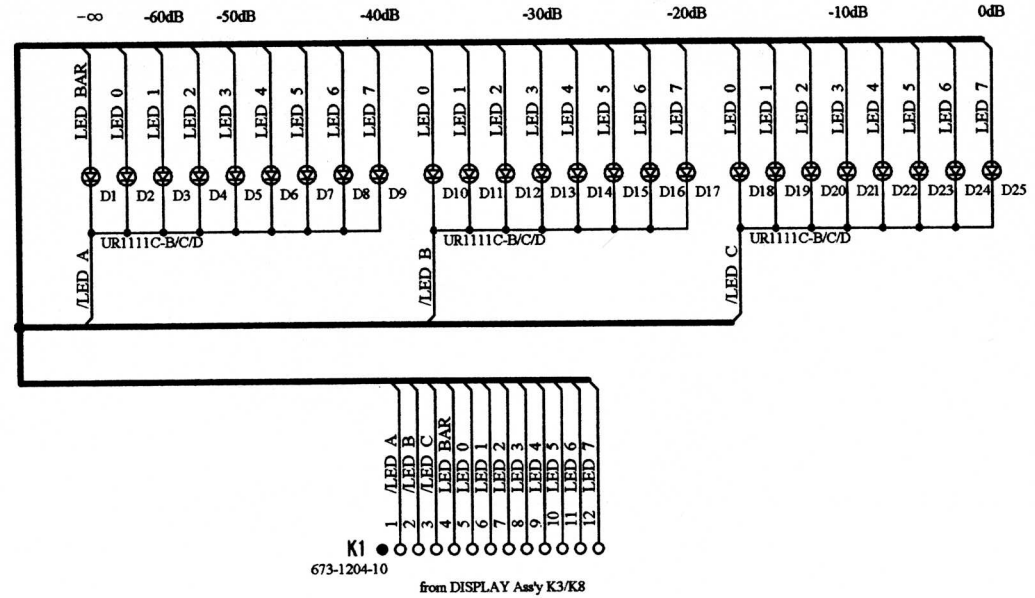

POWER AMP ASS'Y (717-0096-00)

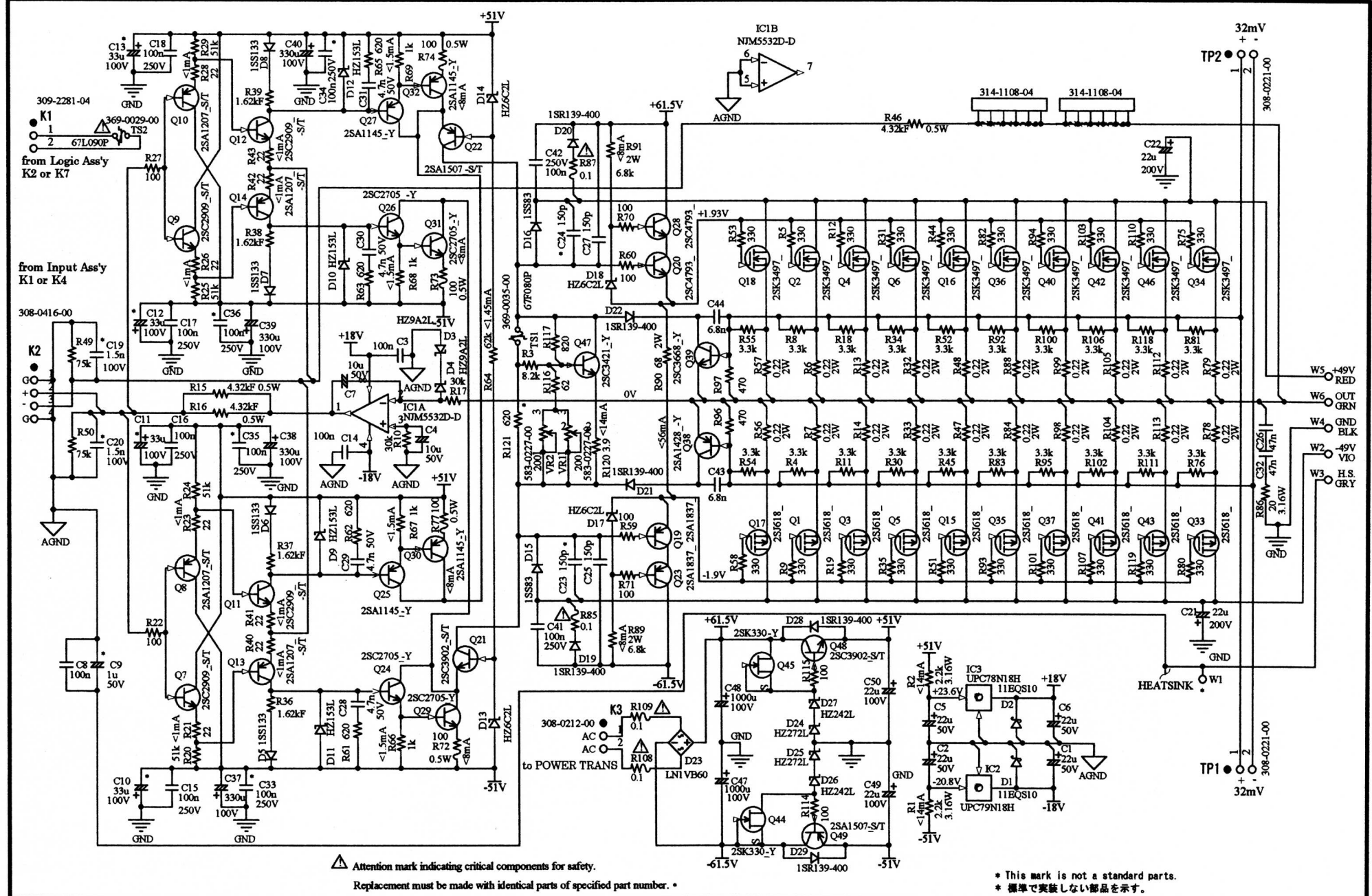

△ Attention mark indicating critical components for safety.
 Replacement must be made with identical parts of specified part number. *

* This mark is not a standard parts.
 * 標準で実装しない部品を示す。

PROTECTION ASS'Y (720-0084-00)

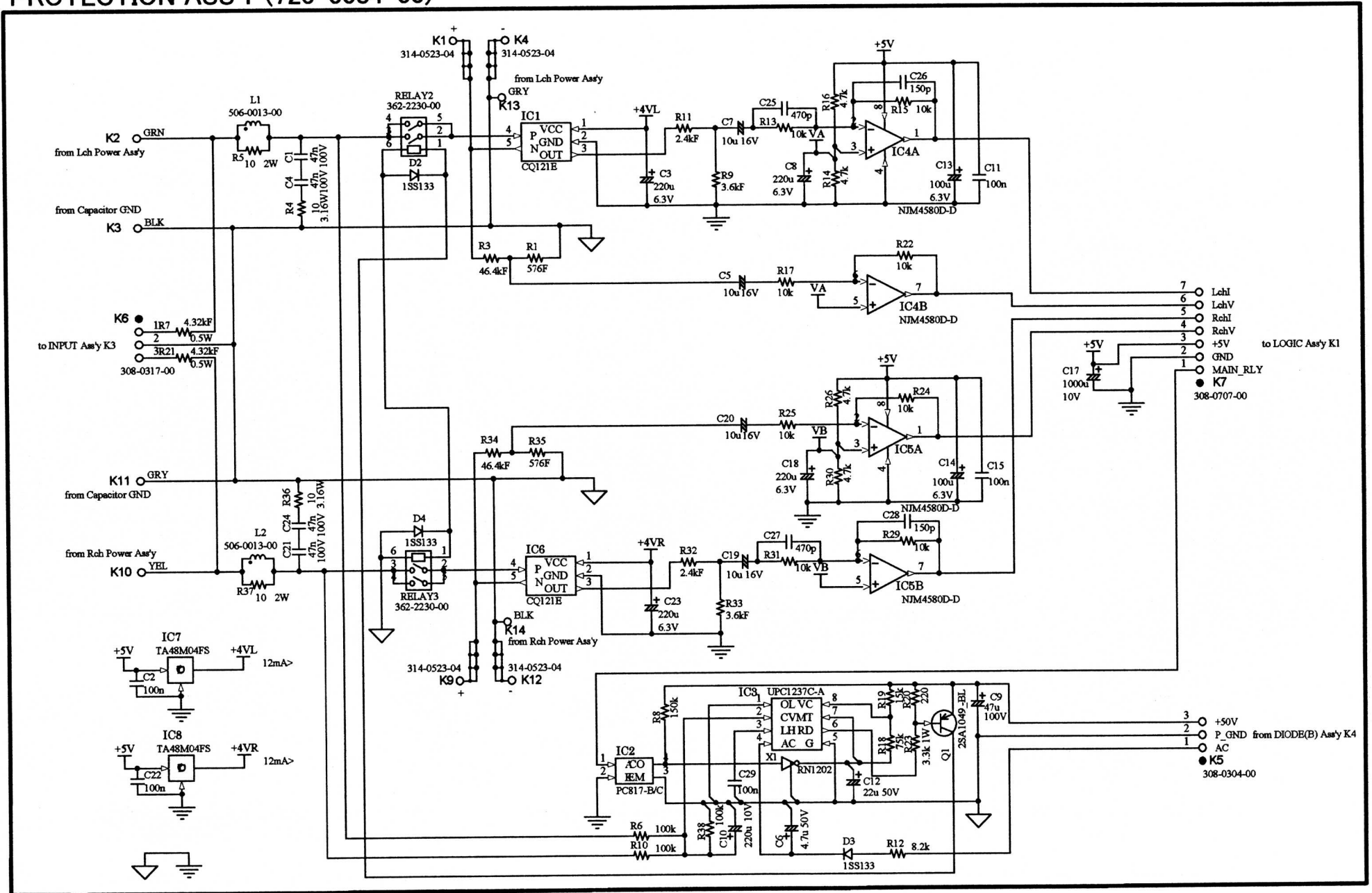

LOGIC ASS'Y (721-0095-00)

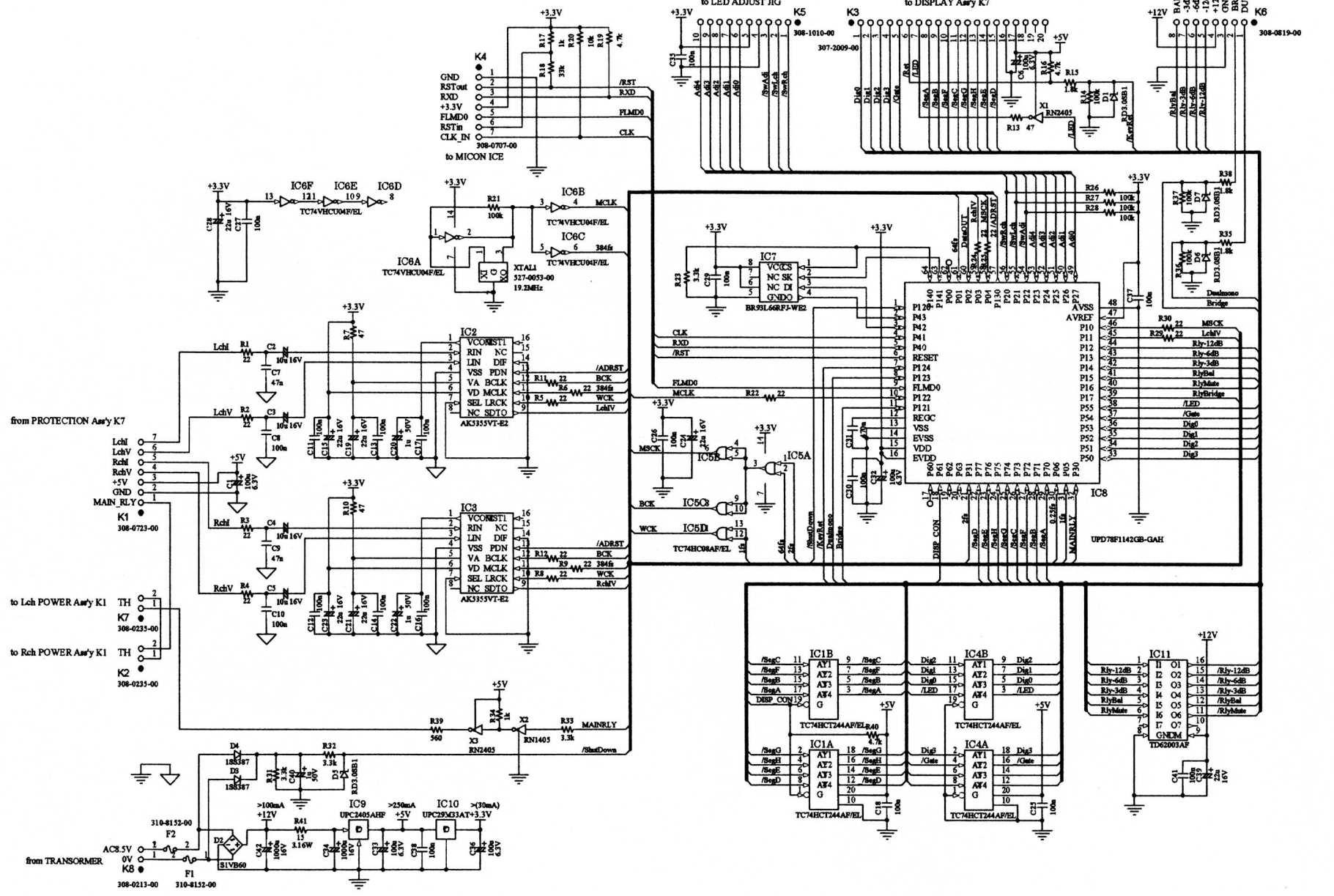

DISPLAY ASS'Y (723-0154-00)

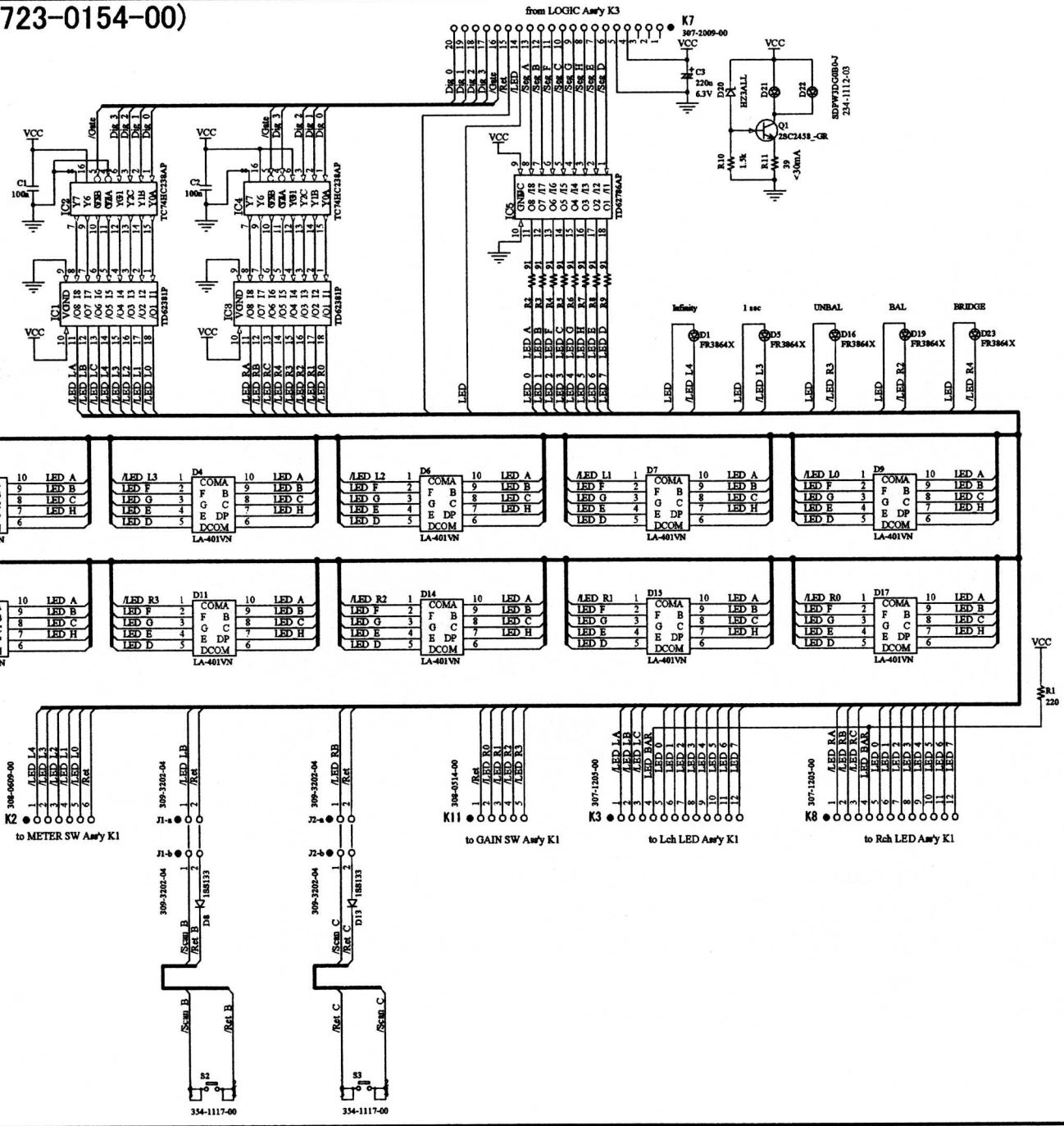

BLOCK DIAGRAM (ブロックダイアグラム)

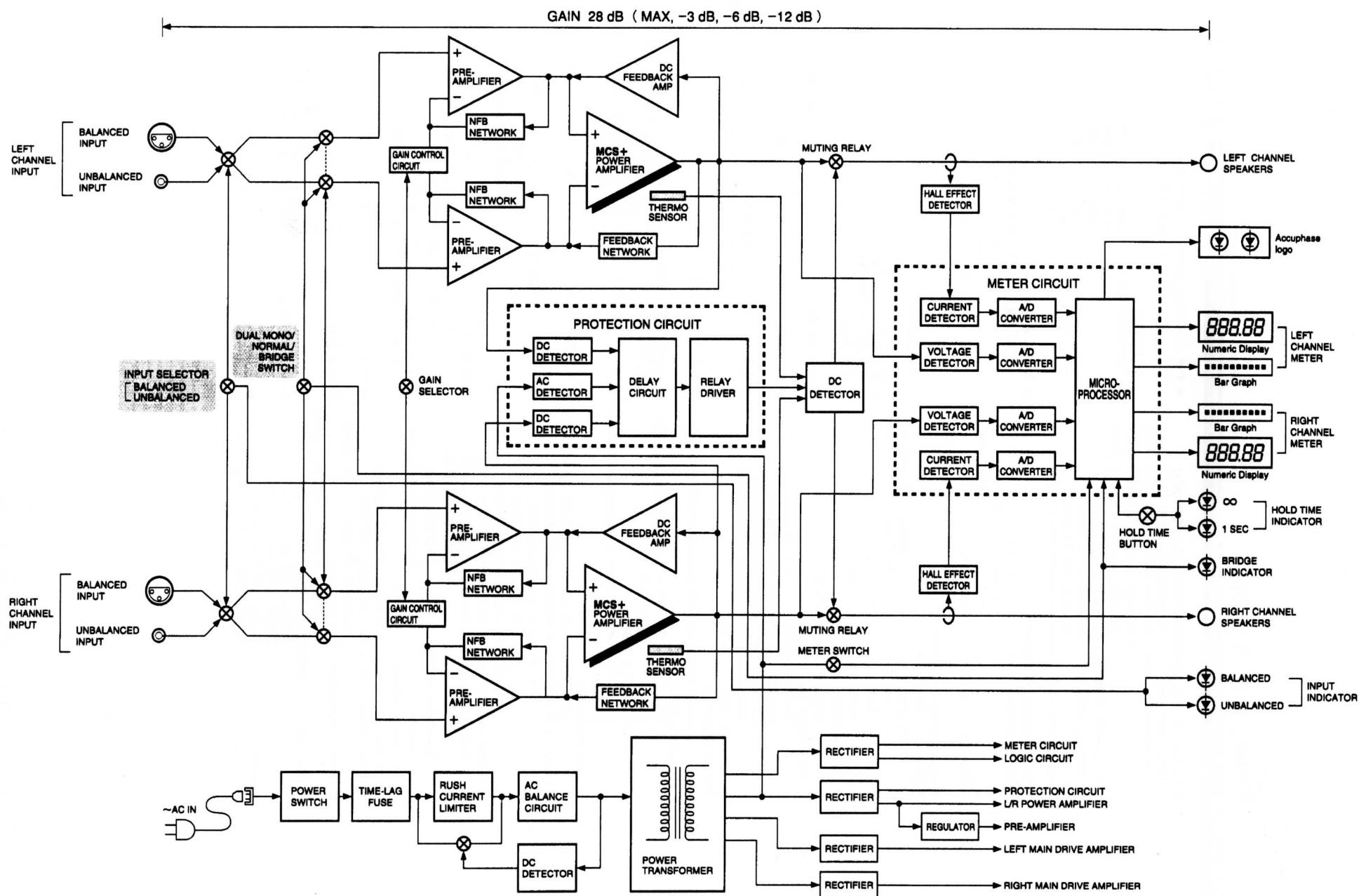

SPECIFICATIONS

[Guaranteed specifications are measured according to EIA standard RS-490.]

- **Continuous Average Output Power (20~20,000Hz)**
Stereo operation 480watts per channel into 1 ohm(*)
(both channels driven) 240watts per channel into 2 ohms
120watts per channel into 4 ohms
60watts per channel into 8 ohms
Monophonic operation 960watts into 2 ohms(*)
(bridged connection) 480watts into 4 ohms
240watts into 8 ohms

Note: Load ratings marked (*) apply only to operation with music signals.

- **Total Harmonic Distortion**
Stereo operation (both channels driven)
0.07%, with 2 ohm load
0.05%, with 4 to 16 ohm load
Monophonic operation (bridged connection)
0.03%, with 4 to 16 ohm load
0.01%

- **Intermodulation Distortion** 0.01%
- **Frequency Response**
At rated output: 20 - 20,000Hz +0, -0.2dB
At 1 watt output: 0.5 - 160,000Hz +0, -3.0dB

- **Gain** 28.0dB (with GAIN selector at MAX)
(stereo and monophonic operation)

- **Gain Selection**
MAX, -3dB, -6dB, -12dB

- **Output Load Impedance**
Stereo operation: 2 to 16 ohms
Monophonic operation: 4 to 16 ohms

[With music signals only, 1-ohm loads are permissible for stereo operation and 2-ohm loads for monophonic operation.]

- **Damping Factor** 400
- **Input Sensitivity**
(with 8-ohm load, GAIN selector in MAX position)
Stereo operation:
0.87 V for rated continuous average output (60W)
0.11 V for 1 watt output
Monophonic operation:
1.74 V for rated continuous average output (240W)
0.11 V for 1 watt output

- **Input Impedance**
Balanced: 40 kilohms Unbalanced: 20 kilohms

- **Signal-to-Noise Ratio (A-weighted, input shorted)**
115 dB (GAIN selector as MAX)
121 dB (GAIN selector as -12dB)
At rated continuous average output

- **Output Level Meters (digital indication and bar graph)**
Digital meters: 5-digit indication, selectable range:
10W/100W/1000W
Bar graph meters: 25-point i scale
Hold time: 1 second/∞, switchable
* Display off setting provided
* Monophonic operation: same value for left/right

- **Power Requirements** AC120V/230V, 50/60Hz
(Voltage as indicated on rear panel)
- **Power Consumption** 280 watts idle
530 watts accordance with IEC 60065
- **Maximum dimensions** Width 465 mm (18-5/16")
Height 238 mm (9-3/8")
Depth 515 mm (20-1/4")
- **Mass** 43.0kg (94.8 lbs) net
52.0kg (114.6 lbs) in shipping carton

- **定格連続平均出力 (20~20,000Hz間)**

注意: ※印の負荷は、音楽信号に限る。

ステレオ仕様時 (両チャンネル同時動作)	480W/ch 240W/ch 120W/ch 60W/ch	1Ω 負荷※ 2Ω 負荷 4Ω 負荷 8Ω 負荷
モノフォニック仕様時 (ブリッジ接続)	960W 480W 240W	2Ω 負荷※ 4Ω 負荷 8Ω 負荷

- **全高調波ひずみ率**

ステレオ仕様時 (両チャンネル同時動作)	0.07% 0.05%	2Ω 負荷 4~16Ω 負荷
モノフォニック仕様時 (ブリッジ接続)	0.03%	4~16Ω 負荷

- **IMひずみ率** 0.01%

- **周波数特性**
定格連続平均出力時 : 20~20,000Hz +0-0.2dB
1W出力時 : 0.5~160,000Hz +0-3.0dB

- **ゲイン(利得)** 28.0dB (GAINスイッチ: MAX時)
(ステレオ/モノフォニック仕様時共)
- **ゲイン切替** MAX, -3dB, -6dB, -12dB

- **負荷インピーダンス** ステレオ仕様時 2~16Ω ※音楽信号に限り、ステレオ
モノフォニック仕様時 4~16Ω 1Ωとモノフォニック2Ω負荷可能

- **ダンピング・ファクター** 400

- **入力感度 (8Ω 負荷 GAINスイッチ: MAX時)**
ステレオ仕様時 0.87V 定格連続平均出力 (60W) 時
0.11V 1W出力時
モノフォニック仕様時 1.74V 定格連続平均出力 (240W) 時
0.11V 1W出力時

- **入力インピーダンス** バランス 40kΩ、アンバランス 20kΩ

- **S/N (A補正、入力ショート)** 115dB GAINスイッチ MAX
121dB GAINスイッチ -12dB
定格連続平均出力時

- **出力メーター (デジタルおよびバーグラフ)**
デジタル・メーター 5桁表示、レンジ切替 (10W/100W/1000W)
バーグラフ・メーター 25ポイント表示
ホールド・タイム 1秒/∞切替式
*表示消灯機能付き *モノフォニック仕様時: 左右同一値表示

- **電源** AC100V 50/60Hz

- **消費電力** 280W 無入力時
530W 電気用品安全法
380W 8Ω 負荷定格出力時

- **最大外形寸法** 幅465mm × 高さ238mm × 奥行515mm

- **質量** 43.0kg